



BRAND

Once you know what you want, you'll want to know what you want.

And you'll want to know what you want. Big name companies don't always have the best products.

And you'll want to know what you want. The only way to know what you want is to see it. And you'll want to know what you want. The only way to know what you want is to see it.

And you'll want to know what you want. The only way to know what you want is to see it. And you'll want to know what you want. The only way to know what you want is to see it.

And you'll want to know what you want. The only way to know what you want is to see it. And you'll want to know what you want. The only way to know what you want is to see it.

And you'll want to know what you want. The only way to know what you want is to see it. And you'll want to know what you want. The only way to know what you want is to see it.

And you'll want to know what you want. The only way to know what you want is to see it. And you'll want to know what you want. The only way to know what you want is to see it.

ALUMINUM ARCHITECTURAL PRODUCTS CORPORATION

ALUMINUM ARCHITECTURAL PRODUCTS CORPORATION
10000 WEST 10TH AVENUE, DENVER, COLORADO 80231

Aluminum. The name to remember.

Circle 1 on information card

**“You don't have to be
the biggest to be insured
by the best.”**

“Shand, Morahan?”

“Shand, Morahan.”



It's the growing consensus of the leading architectural and engineering firms in the land: the E&O program available through Shand, Morahan & Company is about the best coverage you can have, at a most competitive premium rate. That's why so many of the ENR top 500 design and construction firms are choosing our insurance.

But your firm doesn't have to be among the biggest to enjoy the best in Architects and Engineers Professional Liability insurance. Shand, Morahan also extends its uniformly excellent claims-made program and unmatched standard of service to more and more medium and smaller-sized firms as well. These firms enjoy the same experience and attention that only the nation's foremost source for professional liability insurance can provide.

If your present Architects and Engineers Liability policy or premium might benefit from an analysis and comparison with ours, we welcome your insurance broker's inquiry. Whether you're among the biggest, or just want the best.

**SM Shand, Morahan
& Company, Inc.**

One American Plaza, Evanston IL 60201

Circle 2 on information card



“If I could say just one thing to architects about Permalite PK Plus® roof insulation, it would be — Relax.”

Monty Moore
Pacific-Rainier Roofing Co.
Seattle, Washington

Relax, because you've specified great insulation and the best platform for a long-lasting, trouble-free BUR — Permalite PK Plus. It's the factory-manufactured platform that's perlite-urethane-perlite chemically bonded together to be stable, dry and economical. Top roofers like Monty Moore trust it to give architects like you a product proven in thousands of installations under all climatic conditions.

If Permalite PK Plus makes as much sense to you as it does to roofers and other architects, then contact us for technical data and free sample.

Grefco, your single source for Permalite® perlite-urethane, perlite-urethane and PK Plus insulation boards. For technical data and free sample write Grefco Inc., Building Products Division, 3450 Wilshire Blvd., Los Angeles, CA 90010.

 GREFCO a subsidiary of
General Refractories Company

Permalite®
Insulation Board

CONTENTS

The American Institute of Architects

Officers

Charles E. Schwing, FAIA, *President*
 R. Randall Vosbeck, FAIA, *First Vice President*
 Gerald L. Clark, FAIA, *Vice President*
 Anna M. Halpin, FAIA, *Vice President*
 Thomas H. Teasdale, FAIA, *Vice President*
 Robert M. Lawrence, FAIA, *Secretary*
 J. W. Barnes, FAIA, *Treasurer*
 David Olan Meeker Jr., FAIA, *Executive Vice President*









Directors (Year indicates expiration of term)

William Blurock, FAIA ('82), *California*
 James C. Dodd, AIA ('81), *California*
 Donald L. Hardison, FAIA ('80), *California*
 Harry W. Harmon, FAIA ('80), *California*
 R. Bruce Patty, FAIA ('82), *Central States*
 Henry W. Schirmer, AIA ('81), *Central States*
 P. Whitney Webb, AIA ('82), *East Central States*
 Ellis W. Bullock Jr., AIA ('81), *Florida/Caribbean*
 E. H. McDowell, FAIA ('81), *Florida/Caribbean*
 Gaines B. Hall, AIA ('81), *Gulf States*
 Ray K. Parker, AIA ('80), *Gulf States*
 Raymond C. Ovresat, FAIA ('81), *Illinois*
 Paul D. Bowers Jr., AIA ('80), *Michigan*
 David A. Holtz, AIA ('80), *Middle Atlantic*
 James R. Nelson, AIA ('81), *Middle Atlantic*
 John Avery Carter, AIA ('82), *New England*
 George M. Notter Jr., FAIA ('80), *New England*
 Harold D. Glucksman, AIA ('80), *New Jersey*
 Joseph Monticciolo, AIA ('82), *New York*
 William A. Rose Jr., AIA ('81), *New York*
 Leroy Bean, AIA ('82), *North Central States*
 Edwin B. Crittenden, FAIA ('81), *Northwest*
 William H. Trogdon, FAIA ('80), *Northwest*
 Robert Gramann, AIA ('82), *Ohio*
 Derek Martin, AIA ('81), *Pennsylvania*
 John A. Busby Jr., FAIA ('82), *South Atlantic*
 Michael D. Newman, AIA ('80), *South Atlantic*
 William Caudill, FAIA ('82), *Texas*
 Theodore S. Maffitt Jr., FAIA ('81), *Texas*
 Pat Y. Spillman, FAIA ('81), *Texas*
 Thomas B. Muths, AIA ('82), *Western Mountain*
 John B. Rogers, FAIA ('81), *Western Mountain*
 Robert B. Pease, Hon. AIA, *ex officio, Public Director*

Alex Barberena, *ex officio, President, ASC/AIA*
 Ann Stacy, Hon. AIA, *ex officio, Chairwoman, Council of Architectural Component Executives*

Headquarters

David Olan Meeker Jr., FAIA, *Executive Vice President*
 James A. Scheeler, FAIA, *Group Executive, Program and Services Management*
 Alan B. Stover, AIA *Acting General Counsel*
 James A. Schuping, *Assistant Secretary*
 William G. Wolverton, Hon. AIA, *Assistant Treasurer/Controllor*
 Michael B. Barker, AICP, *Administrator, Practice and Design*
 Francis X. Brown, *Administrator, Conventions*
 Auriel Campaglia, *Administrator, Public Relations*
 James E. Ellison, AIA, *Administrator, Education and Professional Development*
 David S. Godfrey, *Administrator, Publications*
 Arnold J. Prima Jr., AIA, *Administrator*
 John Wilson-Jeronimo, *Administrator, Component Affairs*
 Government Affairs
 David Olan Meeker Jr., FAIA, *President, AIA Corporation*
 Jeanne Butler Hodges, *President, AIA Foundation*
 Charles R. Ince Jr., *President, AIA Research Corporation*
 John H. Schruben, FAIA, *President, Production Systems for Architects and Engineers, Inc.*

15		Basic Facts About AIA
24		A Summary of AIA Policies on Public Issues
42		The Workings of the AIA Committee System
52		The AIA Building at Age 7
60		Contacts for Help at AIA
66		Glossary of Acronyms and Abbreviations
75		Directory of AIA Resources (Yellow Pages)
114		Books to Order Through the Institute
134		Sources for AIA Contracts and Forms
138		Resources from Suppliers and Manufacturers

Cover: Photograph by Allen Freeman of the Octagon and its courtyard.

Donald Canty, Editor; Suzy Thomas, Art Director; Carole Palmer, Associate Art Director; Stanley Abercrombie, AIA, Senior Editor, Architecture; Mary E. Osman, Senior Editor, Departments; Andrea O. Dean, Senior Editor, Articles; Allen Freeman, Managing Editor; Nora Richter Greer, Associate Editor; Virginia Dart, Editorial Assistant; Michael J. Hanley, Publisher; Michael M. Wood, National Sales Director; George L. Dant, Production and Business Manager; Terry L. Peck, Circulation Manager; David S. Godfrey, General Manager

The AIA JOURNAL, publication number: ISSN0001-1479, official magazine of The American Institute of Architects, is published 14 times yearly at 1735 New York Ave. N.W., Washington, D.C. 20006. **Subscriptions:** for those who are, by title, architects, architectural employees and to those in architectural education (faculty, schools and students), and to libraries, building construction trade associations and building products manufacturers: base rate \$12 a year in the U.S., its possessions and Canada. For all others: \$18 a year in the U.S., its possessions and Canada; other countries to those who are by title, architects: \$18 a year. All others outside the U.S., its possessions and Canada: \$30 a year. Single copies, \$2.50 each. Publisher reserves the right to refuse unqualified subscriptions. For subscriptions: write Circulation Department; for change of address: send Circulation Department both old and new addresses; allow six weeks. Quotations on reprints of articles available. Microfilm copies available from University Microfilm, 300 N. Zeeb Road, Ann Arbor, Mich. 48106. Referenced in *The Architectural Index, Architectural Periodicals Index, Art Index, Avery Index to Architectural Periodicals*. Second class postage paid at Washington, D.C., and additional mailing offices. © 1980 by The American Institute of Architects. Opinions expressed by the editors and contributors are not necessarily those of AIA. VOL. 69, NO. 10.



Introducing...a barrier-free entrance that serves the special needs of handicapped people, complies with varying state and local codes...and yet meets the demands of normal traffic flow.

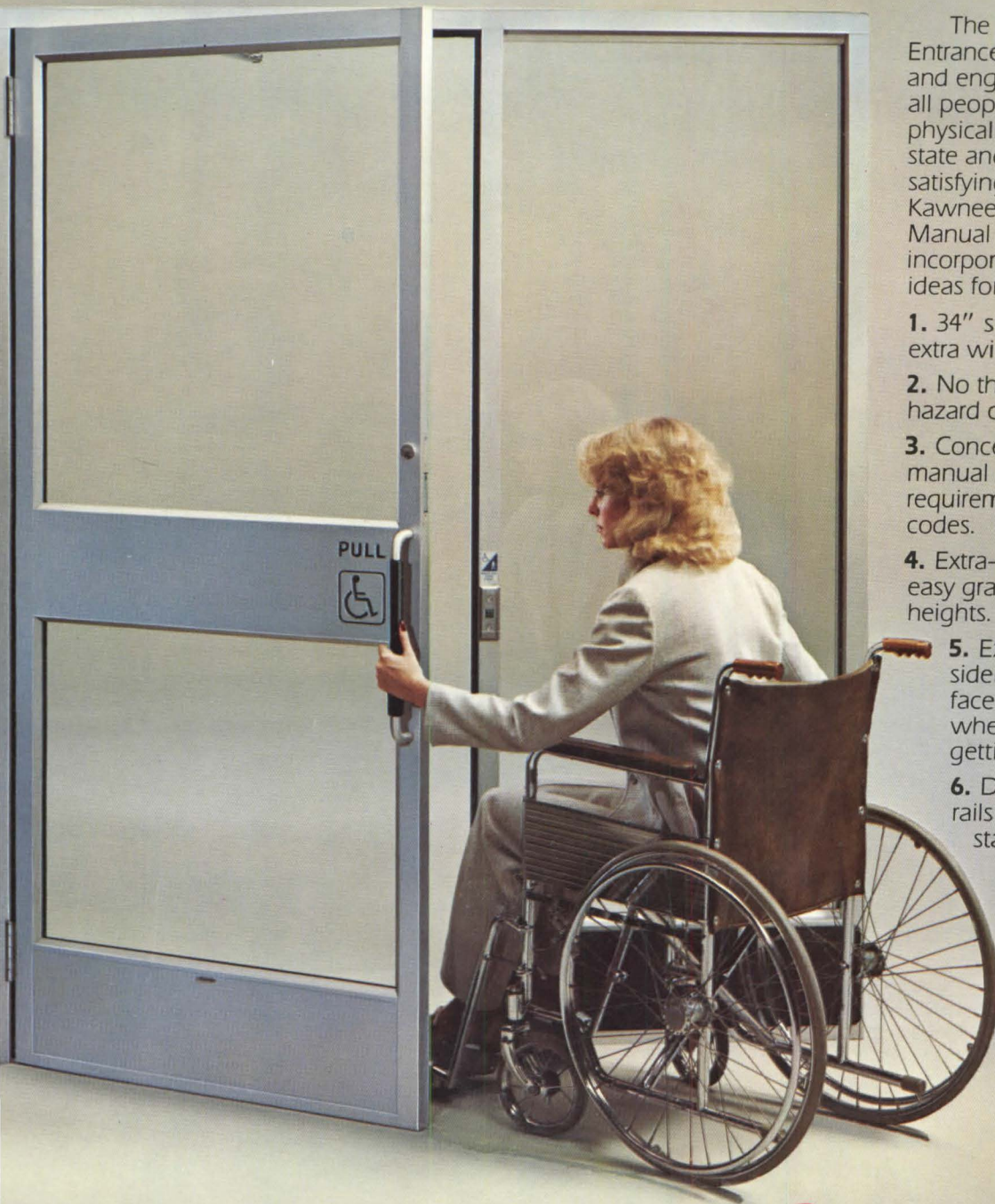

The Kawneer Barrier Free Manual Entrance System has been designed and engineered to serve the needs of all people, including those who are physically impaired. Now, meeting state and local codes, as well as satisfying human needs is as easy as Kawneer Series 800 Barrier Free Manual Entrances. And, they incorporate the most recent design ideas for handicapped use:

1. 34" standard clear door opening for extra width convenience.
2. No threshold to create stumbling hazard or obstruct wheeled traffic.
3. Concealed or surface-mounted manual closers meet reduced force requirements of most accessibility codes.
4. Extra-length door pulls (15 3/4") for easy grasping and convenience for all heights.
5. Exterior and interior surfaces of sidelite base rail are flush with face of lock jamb to prevent wheelchairs and crutches from getting caught.
6. Door bottom rails and sidelite base rails available in 10", 12", or 16" standard heights.
7. Surface applied wear shields to protect door and frame impact areas.
8. Rounded corners and tapered door stops on frame help prevent scraped knuckles and snagged appliances.

Kawneer Series 800 Barrier-Free Manual Entrances

A unique manual door closer eliminates the need for power openers, automatic operators or other expensive entry devices. Handicapped persons can significantly reduce the force they must exert to open the door by just pressing the button located near the doorway.



For additional information contact your Kawneer representative, or write to: The Kawneer Company, 1105 N. Front St., Niles, MI 49120

Kawneer
The designer's element

Circle 4 on information card

The American Institute of Architects

Energy Planning for Buildings

Michael M. Sizemore AIA
Henry Ogden Clark AIA
William Ostrander PE

Building owners expect their architects and engineers to have the practical knowledge it takes to translate energy theory into a reliable form of practice.

This book, written by two architects and an engineer who have hands-on experience in energy-conscious building design and redesign, does just that. It presents a proven process that design professionals can use (or adapt) to study the present energy performance of a building, uncover opportunities for energy-conscious improvements, evaluate those opportunities, and see to it that they are carried out to the owner's best benefit.

The book describes in detail a manual technique for calculating energy usage and shows in a sample problem how that technique can be applied. This allows the reader to evaluate any energy design solution, including solar assisted alternatives. It also provides a basis for understanding computer-aided energy estimating techniques.

In developing their work, the authors have recognized that non-energy related concerns such as user comfort, environmental impact and visual appearance are as important in an energy-related design as energy performance itself, and they urge designers to iden-

tify these at the outset of a project and to keep them in mind to the end.

An opening chapter offers a look at the basic concerns of energy planning, including such concepts as comfort; illumination and daylighting; the building envelope; heating, ventilating and air-conditioning; and the very concept of energy itself.

Chapter 2 takes up the roles and responsibilities of the team needed to carry a project through to a successful end. Team members discussed include the owner, the architect/engineer, the building users and operators, energy suppliers, product manufacturers and building officials.

Chapter 3, a key part of the book, shows how to study a building's present performance (or, in the case of a new building, analyze a set of building plans) so the energy planner can examine the impact of any proposed changes suggested as a way to greater energy efficiency.

Chapter 4 pinpoints those opportunities, describing the best way of identifying them. The following Chapter 5 then shows how best to narrow the list of possibilities to those that make the most sense in terms of cost, time, payback and technical feasibility. Two

levels of evaluation are given—"quick" and "detailed."

Chapter 6 shows what is needed to carry out the recommendations stemming from the evaluation, and offers much sound advice to the energy planner and owner for monitoring the results and maintaining the renewed building at a peak of performance.

This chapter is followed by a sample problem which illustrates the procedural steps presented in the various chapters.

Finally, an appendix includes discussions on system response and cost benefit analysis.

There is also a glossary and a practical reference list.

ENERGY PLANNING FOR BUILDINGS fills a serious need for a practical, process-oriented book which energy planners can use, and owners can refer to, as they embark on a new building project or go about redesigning an existing one for greater energy efficiency.

156 pages, 120 charts and illustrations.

\$40 AIA Members
\$44 Others

The American Institute of Architects

Yes, I would like _____ copy (copies) of ENERGY PLANNING FOR BUILDINGS (#4M-720)

Enclosed is my check for _____

Mail to: Manager, AIA Publications Marketing
1735 New York Avenue, N.W.
Washington, DC 20006

NAME _____

FIRM _____

ADDRESS _____

CITY, STATE, ZIP _____

IDENTIFY AIA MEMBER _____

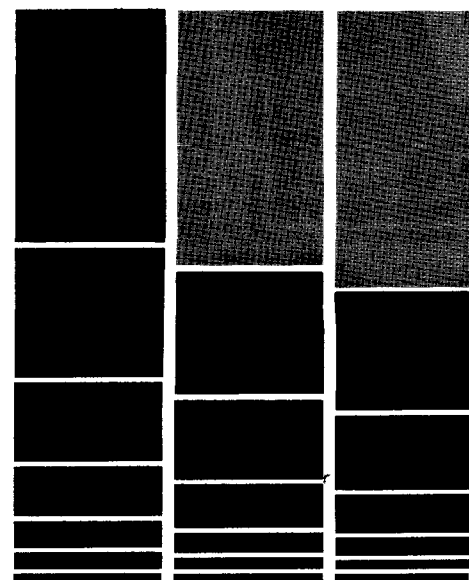

The Offenburg stacking chair is suited for hotels, restaurants and highly trafficked areas where seating is exposed to severe use. This series includes modular benches, stadium seats, chairs, tables and lounges, all from synthetic coated steel.

Kroin

ARCHITECTURAL COMPLEMENTS

OFFENBURG
Design: Heinz Wirth

Post Office Box 168, Lincoln, Massachusetts 01773
617 259 0129



Circle 6 on information card

VULCRAFT IMPORTANT ROLE ON



PLAYED AN SUPPORTING BROADWAY.



Vulcraft now manufactures a broad line of steel deck along with steel joists and joist girders.



The simplicity and light weight of Vulcraft joists and joist girders make erection fast and easy.

Vulcraft provided steel joists, joist girders and steel deck for the three-story Broadway Executive Building on the Broadway Extension in Oklahoma City.

Since Vulcraft is the only company that manufactures and sells all three, the steel fabricator ordered them all from Vulcraft. By dealing with a single source, he gained several advantages.

When heavy load considerations required specially-designed joists and joist girders, Vulcraft designed just what was needed.

When detailed drawings were called for, Vulcraft provided them for the joists, joist girders and deck.

When simultaneous delivery was requested for all three elements, Vulcraft delivered them together.

When purchase orders were processed, Vulcraft needed one, not three.

And when maximum coordination was required during erection, Vulcraft's ability to deliver joists, joist girders and deck paid off in a savings of time and money for the customer.

So if you'd like the advantages of a single source for steel joists, joist girders and steel deck, talk to Vulcraft.

We'd like to play an important supporting role in your next production. Even if it's Off-Broadway.

Just contact your local Vulcraft representative. Or write Vulcraft, P.O. Box 220646, Charlotte, North Carolina 28222, for our steel deck and joist catalogs.

Architects: Architectural Design Group
Developers: Spaulding and Slye Corp.
Steel Fabricators: Kraeger Structures, Inc.
Steel Erector: Allied Steel Construction Co.

VULCRAFT

A Division of Nucor Corporation.

P.O. Box F-2, Florence, SC 29502 803/662-0381
P.O. Box 169, Fort Payne, AL 35967 205/845-2460
P.O. Box 186, Grapeland, TX 75844 713/687-4665
P.O. Box 59, Norfolk, NE 68701 402/371-0020
P.O. Box 1000, St. Joe, IN 46785 219/337-5411

The Gas Advantage.

You can count on it.

1. Economy

Gas is America's lowest cost energy for space conditioning and water heating, and it will continue to maintain this important advantage in the years ahead.

2. Efficiency

Gas is America's most efficient energy system, and new energy-saving gas equipment makes it even more efficient.

3. Dependability

Gas is America's reliable energy. Our vast underground supplies and potential new sources will mean gas for generations to come.

AGA American Gas Association



Gas: The future belongs to the efficient.

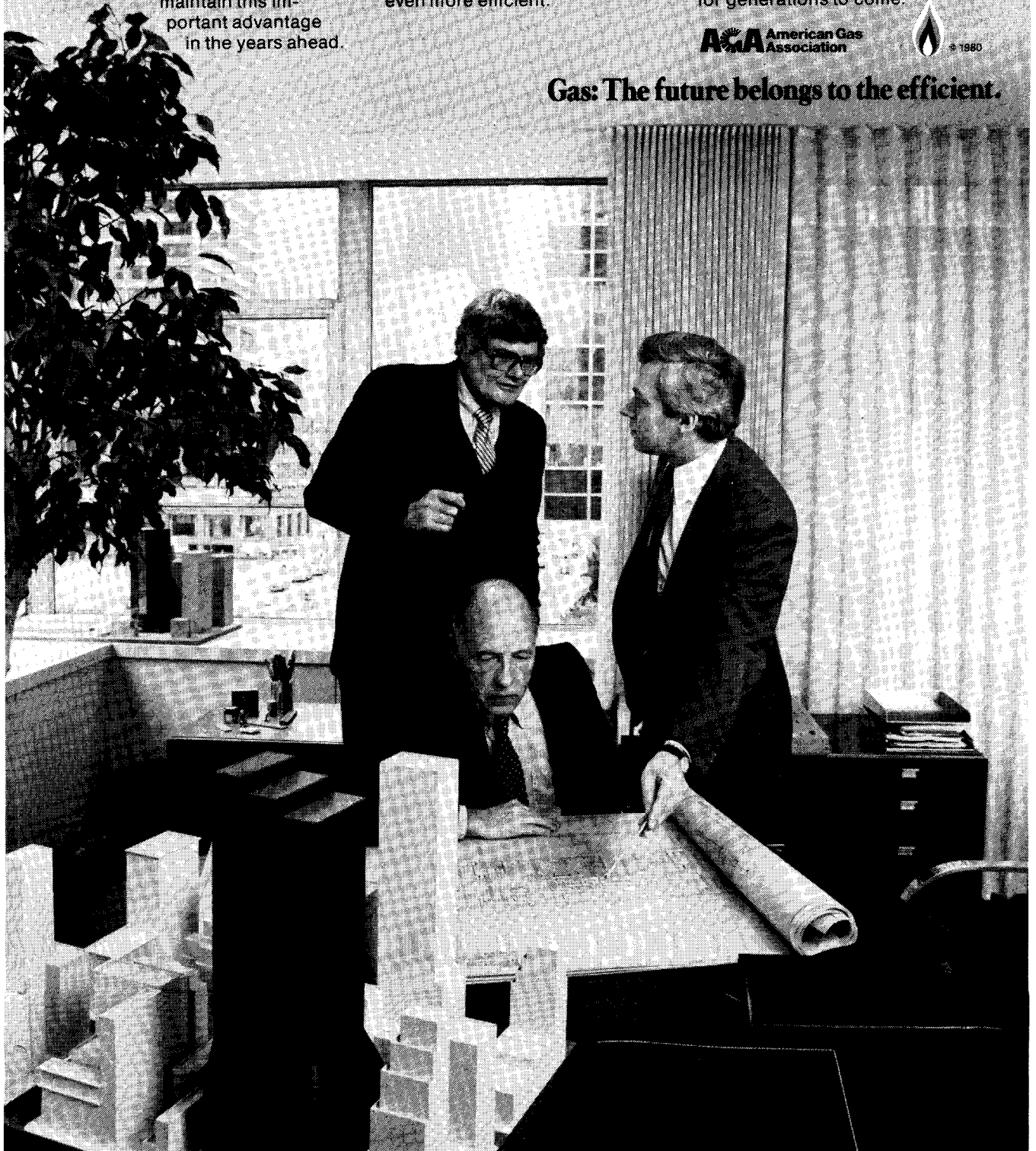

Location: Jackie Robinson Middle School, New Haven, Ct.
General Contractor: The Fusco—Amatruda Company
Architect: Stull Associates, Boston, Mass.



Exposed ductwork is often required in a building design. This may be by necessity or application of the architectural function – beauty design concept. Function may produce beauty, but ductwork needs all the help it can get.

United Sheet Metal's standardized, factory machine-formed duct and fittings make exposed ductwork an economical, attractive, architectural design feature.

Available in both spiral round and flat oval configurations, the complete uniformity and smooth lockseam construction make it a design asset in any exposed installation. And, you can specify any desired paint finish on our 'Paint Grip' galvanized steel duct.

Where noise and thermal control are critical, United's internally insulated, Acousti k-27 duct and fittings are the answer, and provide the same attractive exterior appearance.

How to turn exposed duct into a work of Art

Of course, the beauty of our duct and fittings is more than skin deep. We have been the leading manufacturer of quality, factory-made duct and fittings for all types of commercial and industrial HVAC applications for over a quarter of a century.

Send for our comprehensive Engineering Bulletin on "Exposed Duct Work" - Vol. 1

No. 3. Circle the reader service number below or contact: United Sheet Metal, 200 E. Broadway, Westerville, Ohio 43081. Telephone: 614/882-7401.

United McGill
Corporation

United Sheet Metal

Circle 9 on information card

**Glass creates
always in**

bloom

a look that's season.

A store as stylish as Manhattan-based Bloomingdale's is very particular about the image it portrays. And the "look" it has created for its new White Plains, New York, store is especially dazzling.

All of the upper-floor opaque wall areas are clad in a mirror

finish of silver Vari-Tran[®] coated LOF glass.

Spring, summer, winter, fall, Bloomingdale's Vari-Tran facade reflects the beauty of its wooded, suburban setting. Creating a look that's naturally always in season.

Besides looking good, Bloomingdale's glass facade is virtually maintenance-free. It never needs painting. It can't corrode. Or deteriorate. A

simple washing keeps it sparkling bright season after season after season.

Want more information on Vari-Tran and other types of LOF glass? Check with your nearest LOF supplier. Or write to Larry Moeller, Libbey-Owens-Ford Company, 811 Madison Avenue, Toledo, OH 43695.

g
d
a
i
e
r
s

LOF Glass

A Libbey-Owens-Ford Company



A creative challenge, superbly met.

When the architect finds the solution to a design problem, it's a triumph. At Schinnerer we've been working with architects and engineers in the field of professional liability long enough to appreciate their creativity and expertise — and long enough to be fully aware of the insurance problems they face.

Now we've met a challenge of our own. At a time when the cost of everything else is going up, Continental Casualty Company, one of the CNA insurance companies, has stabilized its rates for a period of at least 27 months (from March, 1978) and added to its Professional Liability Program some new features that can save you money.

One exclusive CNA feature is called the Deductible Credit Plan. It can lower your deductible obligation by as much as 50%, or lower your premium if you select a higher deductible. The Deductible Credit Plan and other new features mean that we can now provide you with the most comprehensive coverage available, at a very reasonable cost.

At Schinnerer and CNA, we're always working to improve our coverage and hold the line on cost. You'll find our latest achievements go a long way toward meeting that challenge. Call your broker and get a quote.

Victor O.
Schinnerer
& Company, Inc.

The first is still the best.

*Program Administrators
and Underwriting Managers*

5028 Wisconsin Avenue, N.W.
Washington, D.C. 20016
Phone: (202) 686-2850

Other offices in:
New York
Chicago
San Francisco

This coverage is underwritten by
Continental Casualty Company

Circle 11 on information card

Basic Facts About AIA

Thirteen men met in the New York City offices of architect Richard Upjohn on Feb. 23, 1857, to form a professional body of architects. A constitution and bylaws were soon drawn up and the newly established organization was called the New York Society of Architects. In the application for a state charter, the name was changed to The American Institute of Architects. Upjohn became the Institute's first president, serving from 1857 through 1875.

Since those early days, chronicled so well by Henry H. Saylor, FAIA, in *The A.I.A.'s First Hundred Years* (published in 1957), the Institute has grown steadily in membership and programs. Currently, there are approximately 33,520 members.

Purposes of AIA are "to organize and unite in fellowship the members of the architectural profession of the United States of America; to promote the esthetic, scientific and practical efficiency of the profession; to advance the science and art of planning and building by advancing the standards of architectural education, training and practice; to coordinate the building industry and the profession of architecture to ensure the advancement of the living standards of people through their improved environment, and to make the profession of ever-increasing service to society."

Membership is open to architects who have demonstrated "honorable standing in the profession and their community," are legal residents of and have been granted a license or registration by any state, the District of Columbia or any U.S. territory and agree to abide by the Institute's bylaws and are willing to accept the "duties, responsibilities, obligations and liabilities" of membership. Application is made to the appropriate local AIA chapter and five references are required from persons residing in that region, three of whom must be members of AIA.

Fellowship is conferred upon members of 10 years' "good standing who have made notable contributions to the advancement of the profession. . . ." Honorary fellowship is given to architects of "esteemed character and distinguished achievements" who are not citizens or residents of the U.S. and who do not practice within the domain of AIA.

Honorary memberships are given to

persons who are not eligible for membership in AIA but who have "rendered distinguished service to the architectural profession of allied arts and sciences." A member who is 70 years of age or has retired at the age of 60 or is unable to practice architecture and has been in good standing for 15 successive years may apply to the Institute's secretary for member emeritus status. The member emeritus enjoys all the rights, privileges and obligations of membership other than the payment of dues.

Policy making: AIA's activities and programs are developed and guided by its board of directors, officers and commissions. Collectively, AIA's members speak with a united voice on matters pertaining to the Institute's purposes. The individual AIA member plays a key role in policy making through service on various committees. Simply stated, policy making starts with an AIA committee, which serves as an early alert system to matters that may have an impact upon the profession. For example, the committee on housing, with a broad representation nationwide of AIA membership, may want to further a particular policy. The committee makes a preliminary investigation of the matter, reviewing existing policies that may relate to the issue. It then develops recommendations which go to the commission responsible for oversight of the committee's activities. The commission studies the proposed policy-making recommendation and, if it is approved, it is placed on the agenda for board debate and action.

Once the board acts, the appropriate headquarters staff is assigned the responsibility for carrying out the policy, with monitoring of activities by the sponsoring commission.

A convention resolution could also suggest that a bylaw change be proposed. In such an instance, a task force or committee could study the issue and make a recommendation for action by the board of directors. Such convention resolutions give the board guidance and direction in terms of policy formulation.

The bylaws may be amended by an affirmative vote of not less than two-thirds of all votes accredited to be cast at any meeting of the Institute. Notice of the proposed bylaw change will have been sent to all members prior to the vote.

OFFICERS

(December 1979-December 1980)

President

Charles E. Schwing, FAIA
721 Government St., #101
Baton Rouge, La. 70802
(504) 344-3000

First Vice President

R. Randall Vosbeck, FAIA
720 N. St. Asaph St.
Alexandria, Va. 22314
(703) 549-9200

Vice President

Gerald L. Clark, FAIA
P.O. Box 10249
Phoenix, Ariz. 85064
(602) 274-9649

Vice President

Anna M. Halpin, FAIA
Sweet's Division,
McGraw-Hill
1221 Avenue of the Americas
New York, N.Y. 10020
(212) 997-3965

Vice President

Thomas H. Teasdale, FAIA
317 N. 11th St.
St. Louis, Mo. 63101
(314) 231-4704

Secretary

Robert M. Lawrence, FAIA
101 Park Ave. Building, #1313
Oklahoma City, Okla. 73102
(405) 272-0405

Treasurer

Jay W. Barnes, FAIA
1600 W. 38th St., #100
Austin, Tex. 78731
(512) 451-8281

Executive Vice President

David Olan Meeker Jr., FAIA
1735 New York Ave. N.W.
Washington, D.C. 20006
(202) 626-7310

DIRECTORS

(year term expires)

California

William Blurock, FAIA (1982)
2300 Newport Boulevard
Newport Beach, Calif. 92660
(714) 673-0300
James C. Dodd, AIA (1981)
2710 "X" St.
Sacramento, Calif. 95818
(916) 452-6411

Donald L. Hardison, FAIA
(1980)

522 Washington St.
San Francisco, Calif. 94111
(415) 981-2025
Harry W. Harmon, FAIA (1980)
650 Edith Way
Long Beach, Calif. 90807
(213) 590-5512

Central States

R. Bruce Patty, FAIA (1982)
825 Wyandotte
Kansas City, Mo. 64105
(816) 474-6910
Henry W. Schirmer, AIA (1981)
3715 S.W. 29th St.
Topeka, Kan. 66614
(913) 273-1361

East Central States

P. Whitney Webb, AIA (1982)
P.O. Box 419
104 Esplanade
Lexington, Ky. 40585
(606) 253-2456

Florida/Caribbean

Ellis W. Bullock Jr., AIA
(1981)
1823 N. Ninth Ave.
Pensacola, Fla. 32503
(904) 434-5445
E. H. McDowell, FAIA (1981)
P.O. Box 3958
St. Thomas, V.I. 00801
(809) 774-5373

Gulf States

Gaines B. Hall, AIA (1981)
Two-Twenty Plaza 2
P.O. Box 433
Dothan, Ala. 36302
(205) 794-7558
Ray K. Parker, AIA (1980)
One Spring St.
Little Rock, Ark. 72201
(501) 372-2900

Illinois

Raymond C. Ovresat, FAIA (1981)
435 N. Michigan, #1515
Chicago, Ill. 60611
(312) 644-3464

Michigan

Paul D. Bowers Jr., AIA (1980)
WBDC, Inc.
150 Ann St. N.W.
Grand Rapids, Mich. 49505
(616) 363-9007

Middle Atlantic

David A. Holtz, AIA (1980)
9300 Georgia Ave.
Silver Spring, Md. 20910
(301) 588-4800

James R. Nelson, AIA (1981)
The Architects Studio, Inc.
Box 157

Montchanin, Del. 19710
(302) 652-3576

New England

John Avery Carter, AIA (1982)
4 Church St.
Nashua, N.H. 03060
(603) 883-6443
George M. Notter Jr., FAIA (1980)
77 N. Washington St.
Boston, Mass. 02114
(617) 227-9272

New Jersey

Harold D. Glucksman, AIA (1980)
1005 Clinton Ave.
Irvington, N.J. 07111
(201) 371-0111

New York

Joseph Monticciolo, AIA (1982)
U.S. Department of HUD, Region II
26 Federal Plaza
New York, N.Y. 10007
(212) 264-4376
William A. Rose Jr., AIA (1981)
44 S. Broadway
White Plains, N.Y. 10601
(914) 682-4862

North Central

Leroy Bean, AIA (1982)
1711 E. 10th St.
Sioux Falls, S.D. 57103
(605) 339-1711

Northwest

Edwin B. Crittenden, FAIA (1981)
801 W. Fireweed Lane
Anchorage, Alaska 99503
(907) 272-3567
William H. Trogdon, FAIA (1980)
W. 1203 Riverside Ave.
Spokane, Wash. 99201
(509) 747-6032

Ohio

Robert Gramann, AIA (1982)
6703 Madison Road
Cincinnati, Ohio 45227
(513) 271-7800

Pennsylvania

Derek Martin, AIA (1981)
100 Ross St.
Pittsburgh, Pa. 15219
(412) 471-6150

South Atlantic

John A. Busby Jr., FAIA (1982)
909 W. Peachtree St. N.W.
Atlanta, Ga. 30309
(404) 892-2890

Michael D. Newman, AIA (1980)
865 W. 4½ St.
Winston-Salem, N.C. 27101
(909) 724-1503

Texas

William Caudill, FAIA (1982)
1111 W. Loop South
Houston, Tex. 77027
(713) 621-9600

Theodore S. Maffitt Jr., FAIA (1981)

510 N. Sycamore
Palestine, Tex. 75801
(214) 729-2433

Pat Y. Spillman, FAIA (1981)
3204 Fairmount
Dallas, Tex. 75201
(214) 748-6488

Western Mountain

Thomas B. Muths, AIA (1982)
P.O. Box FF
Jackson, Wyo. 83001
(307) 733-4217

John B. Rogers, FAIA (1981)
1576 Sherman
Denver, Colo. 80202
(303) 832-5599

Student Director, Ex Officio

President ASC/AIA
Alex Barberena
1735 New York Ave. N.W.
Washington, D.C. 20006
(202) 626-7472

Chairwoman, Council of Architectural Component Executives, ex officio

Ann Stacy, Hon. AIA
Michigan Society of Architects
553 E. Jefferson
Detroit, Mich. 48226
(313) 965-4100

Public Director

Robert B. Pease, Hon. AIA
3018 One Oliver Plaza
Pittsburgh, Pa. 15222
(412) 281-1890 □

**ARCHITECTURE
EDUCATION**

where to study

**programs
available**

**financial aid
information**

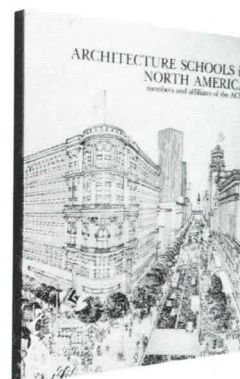

**ARCHITECTURE SCHOOLS
IN NORTH AMERICA:
Members and Affiliates
of the ACSA**

Roger Schluntz and Sarah V. Weaver, Editors

This major reference guide contains the official architecture program descriptions of the 99 member schools and 20 affiliate schools of the Association of Collegiate Schools of Architecture, located throughout the United States and Canada. Compiled in cooperation with the ACSA, this book is a valuable reference tool for students, counselors, and professionals seeking information on undergraduate, first professional, and graduate degrees in architecture and related fields.

Each college's entry provides detailed information on:

- degrees offered and number of degrees conferred
- entrance requirements
- enrollment breakdowns
- costs
- scholarship and loan funds
- graduate and undergraduate program descriptions
- related design fields of study
- application deadlines
- special activities
- faculty members

A national faculty roster identifies all architecture faculty members and their institutions. Separate lists show architecture programs throughout the world and American schools offering specialized architecture degrees.

Return this order form and your check to:

**Publications Marketing
The American Institute of Architects
1735 New York Avenue, N.W.
Washington, D.C. 20006**

Yes, I would like _____ copy (copies) of ARCHITECTURE SCHOOLS
IN NORTH AMERICA (#3M124) @ \$8.95 _____ non-member price
\$8.25 _____ AIA member price

All orders must be prepaid. District of Columbia residents add 5% sales tax.
Foreign orders must include postage in the amount of 20% added to dollar
amount of order.

Total enclosed \$ _____.

_____ firm

_____ name

_____ address

_____ city, state, zip



PERIODICAL SHELVING

Tektonic 100 is beautiful library furniture. So superbly does it make use of both form and substance that it may be considered an art form in itself.

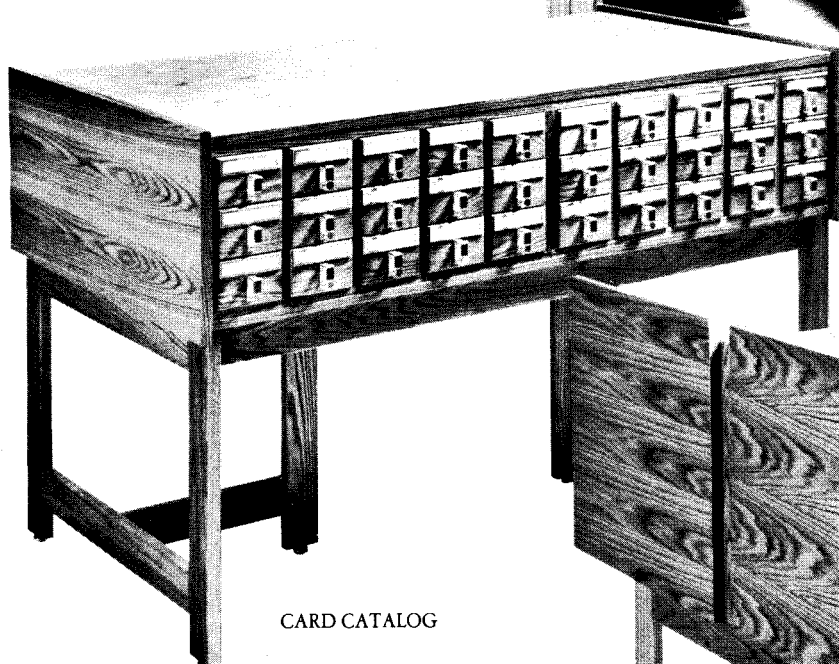

CARD CATALOG

Mellow oak surfaces invite your touch. But more important: the classic human proportions of the Tektonic 100 line invite your use — comfortable, solid, practical as “human engineering” can make it.

Tektonic 100. Furniture with the fluid form of sculpture. Sculpture designed to human scale.

We'd like to show you more. Send for the

Tektonic 100 catalog. Write or call Library Bureau, 801 Park Avenue, Herkimer, NY 13350. (315) 866-1330.

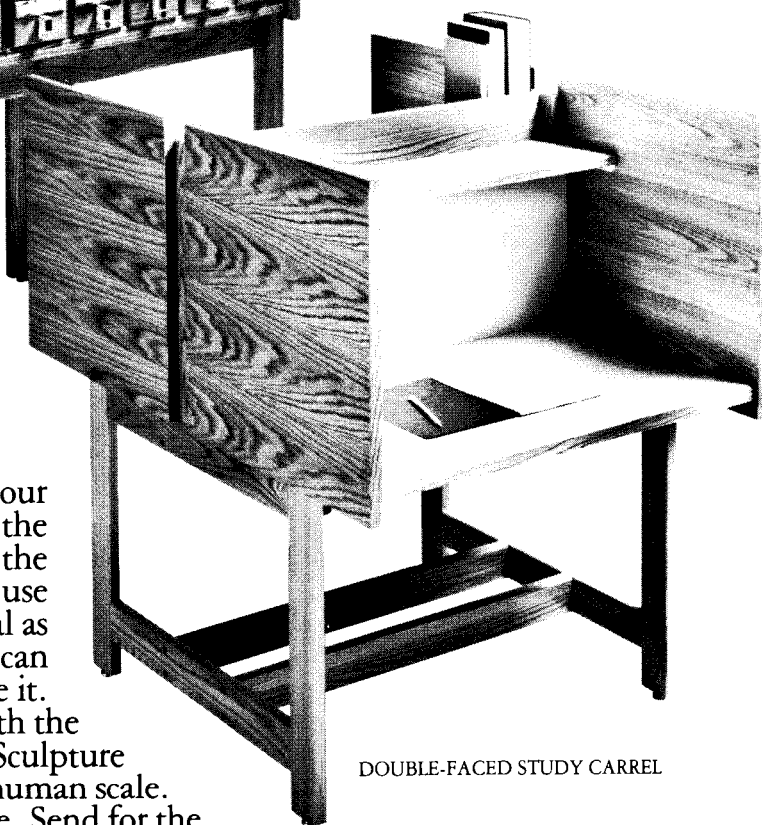

DOUBLE-FACED STUDY CARREL

Tektonic 100 from Library Bureau.

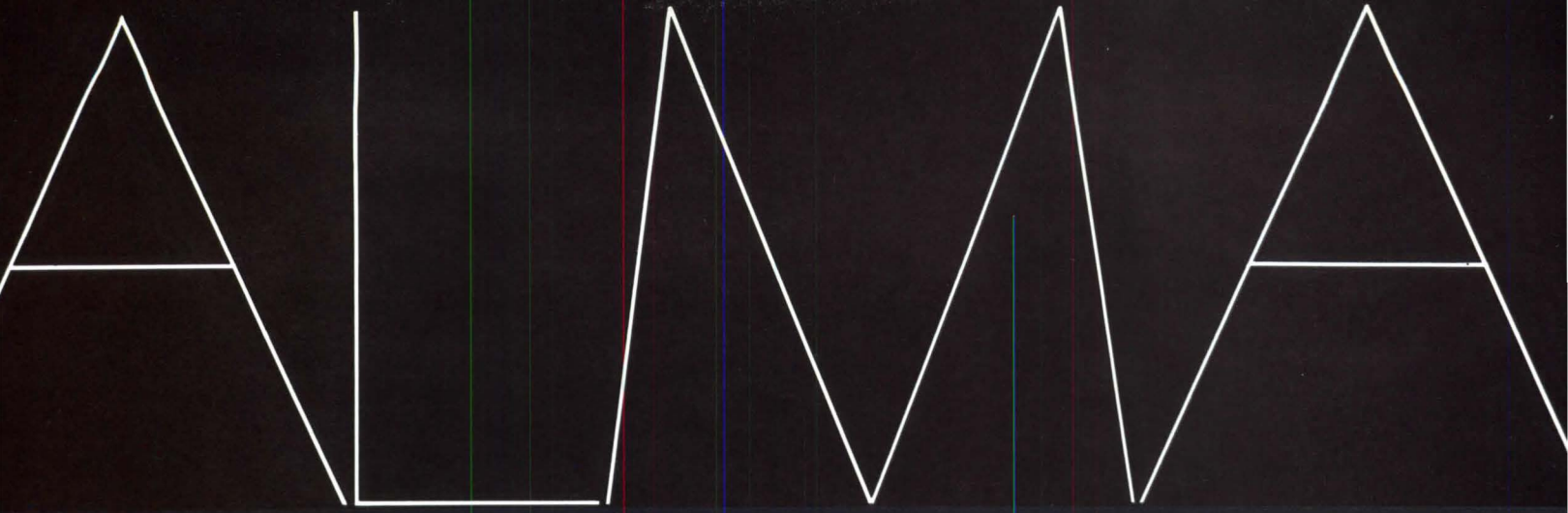

When you want more than just an office



Open plan designs to
set your imagination free. Alma.
This AD office system, plus desks
and seating, all designed for
the designer.

alma

Alma Desk Company, Box 2250, High Point, NC 27261, Showrooms: 919 Third Ave., New York,
1140 Merchandise Mart Plaza, Chicago; Southern Furniture Market Center, High Point,
Atlanta, Dallas, Houston, Kansas City, Seattle, Denver, San Francisco & Los Angeles.

Circle 14 on information card

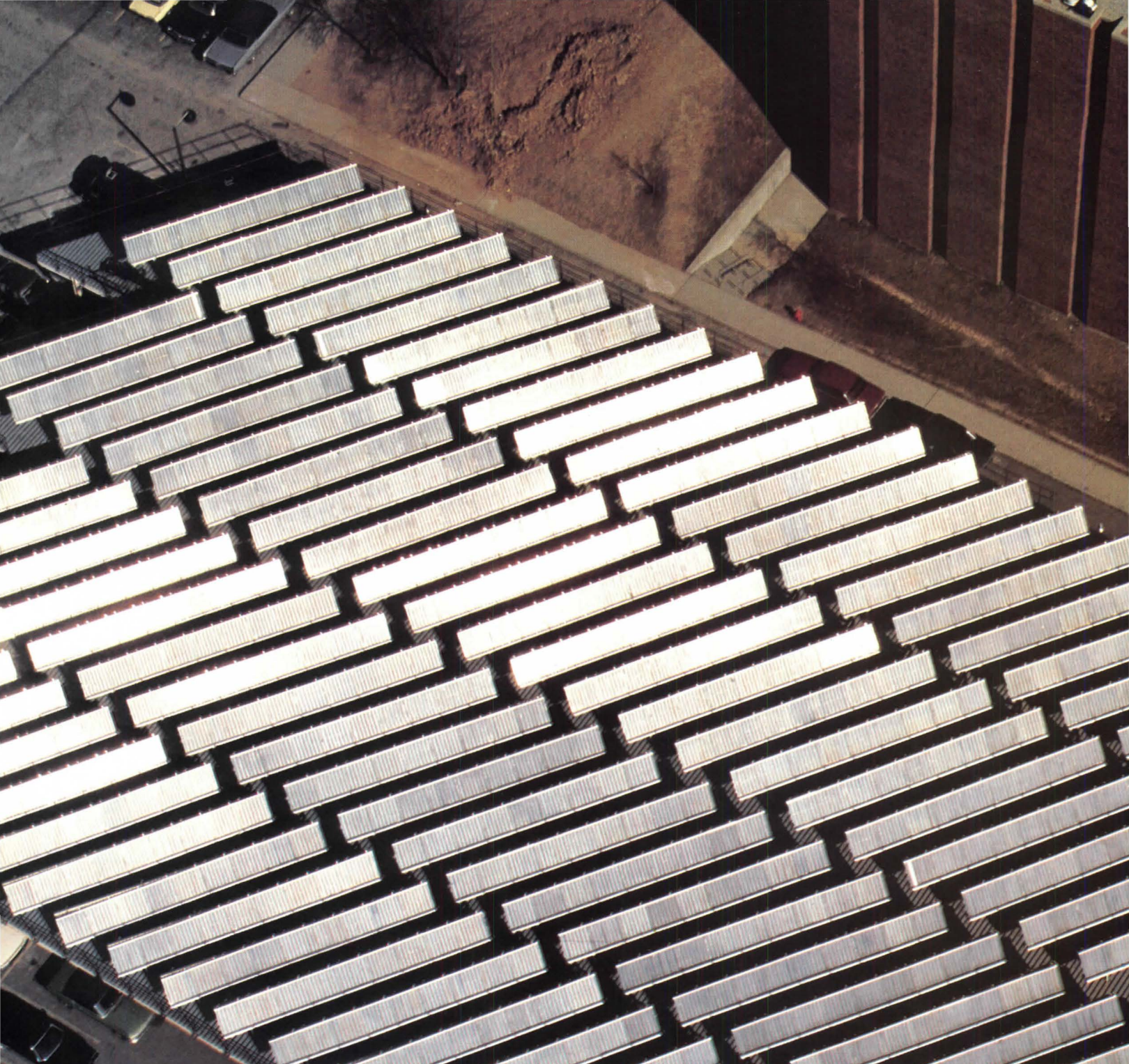

This 11,100 sq. ft. Sunpak installation is teaching Wagner College a lesson in economics — by making a dramatic reduction in fuel costs. Best of all, the sun is an energy source that won't run out. Ever.

“The three billion BTUs we get free from Sunpak™ will mean a \$25,000 fuel savings for us this year.”

Dr. Thomas Henkel
Professor of Physics
Wagner College
Staten Island, New York

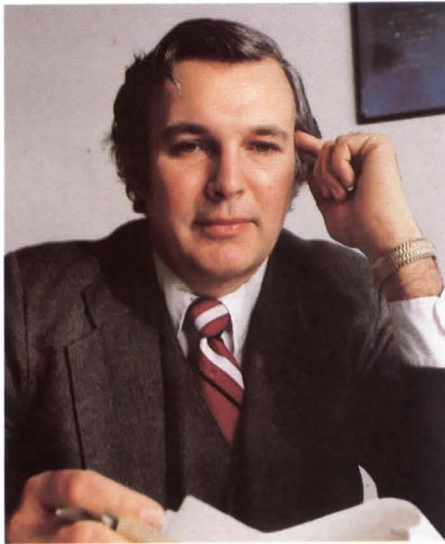

Dr. Thomas Henkel of Wagner College has taken his research out of the laboratory — into the parking lot, where the school's solar collectors have been installed. The system is providing heating, cooling, and domestic hot water for two buildings on campus.

What solar collector did Dr. Henkel choose?

Sunpak solar thermal collectors from Owens-Illinois.

Why?

For a lot of good reasons — among them the fact that Sunpak is an evacuated tube

system ideally suited to Wagner College's geographical location. At certain hours of the day, the angle of the sun is relatively low — and that's when Sunpak shines, busily collecting energy when ordinary flat-plate collectors can't.

In fact, Sunpak can collect and retain up to 4 times more energy than the other systems now available (based on all-day performance).

Want to know more?

Write to us: SUNPAK; Owens-Illinois, Inc.; P.O. Box 1035; Toledo, Ohio 43666. *Today.*

Coca-Cola Bottling Works,
Jackson, Tennessee



Gardens Nursing Home,
Milwaukee, Wisconsin



Columbus Technical Institute,
Columbus, Ohio



Ralph Bunche School,
Atlanta, Georgia

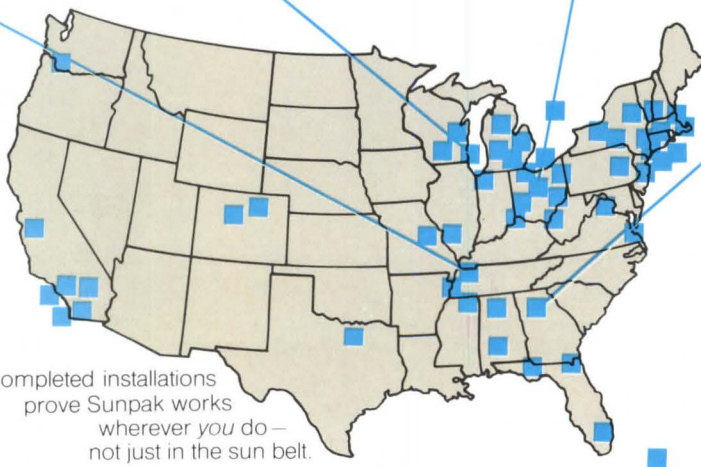

60 completed installations
prove Sunpak works
wherever you do —
not just in the sun belt.

SUNPAK™

Energy Products Group of Owens-Illinois 

A glass pipeline to the sun.

© Owens-Illinois, Inc. 1980

Circle 15 on information card

STYROFOAM
BE

SEALS OUT WATER, LOCKS IN "R"

STYROFOAM* brand insulation seals out the moisture that steals R-value. Tests prove that STYROFOAM, when exposed to moisture and freeze-thaw cycling, retains over 90% of its original R-value.†

Moisture absorption is a cause of thermal resistance deterioration in below grade, sidewall and roof insulation. STYROFOAM, with thirty years of proven performance, repels water and retains R-value from frostline to skyline. That's because

it's made by an exclusive *extrusion* process, resulting in a unique closed-cell structure. This makes STYROFOAM ideal for building insulation applications.

STYROFOAM brand insulation also meets many of the tough new building codes for the most demanding applications, like below grade. There, locked into freeze-thaw cycles for the life of the building, STYROFOAM stands up to brutal punishment, repels moisture and seals in R-value.

STYROFOAM
AND INSULATION

Accept no substitutes. Specify STYROFOAM brand insulation, made only by The Dow Chemical Company. And make sure it's what is actually applied. Then you can be confident that you and your client have invested in the proven answer for energy savings, from frostline to skyline.

For more information, write:
The Dow Chemical Company, STYROFOAM
Brand Insulation, Dept. A00, Midland, MI 48640.

The Proven Answer



*Trademark of The Dow Chemical Company

*Laboratory and Field Investigations to Moisture Absorption and its Effect on Thermal Performance of Various Insulations. Pub. ASTM—STP660, 1978.

WARNING: STYROFOAM brand insulation is combustible and should be properly installed. A gypsum board interior finish should be used in commercial construction. For roofing application STYROFOAM brand insulation should be provided with an adequate protection. For specific instructions see Dow literature available from your supplier or from Dow.

© 1980 The Dow Chemical Company

0-081

Circle 16 on information card

As part of the fulfillment of its responsibilities to society and the profession, AIA's board of directors approves formal policy positions on a broad range of public issues. Public policies are adopted by either resolution of the membership at an annual convention, followed by board ratification, or by independent action of the board itself. A proposal for a policy statement may originate with a member, a component, a committee, a commission, a task force or the board.

If, for example, it comes to the board's attention that a policy may be required in a specific area, the matter will be assigned to the appropriate committee or commission; in the event there appears to be no such existing committee or commission, the board may appoint a task force to prepare a policy statement.

Such statements presented to the board are accompanied by a brief summary report that sets forth AIA's goals and objectives in establishing the proposed policy position, as well as the criteria used in examining the issue and the rationale for the formulation of the proposed policy. Simultaneously, the government affairs commission reviews the proposed policy statement and places it in relationship with existing policies or expresses whether it may be in conflict with such policies.

AIA public policies are not static. The board may review, modify or cancel a policy position or statement at any meeting. Also, each year the government affairs commission asks other Institute commissions to review and make recommendations on all public policies appropriate to their concerns. After review of the recommendations, the board, at its annual meeting, confirms, modifies or cancels such public policies. After notice to the board, any public policy that has not been reviewed by a commission or committee for three years, or otherwise acted upon by the board, is automatically canceled.

The public policies are implemented by monitoring legislation on an array of national concerns. Congressional approval is actively sought for approval of legislation that is in accord with AIA's public policies. Also, through its national congressional and federal agency liaison programs, AIA initiates action on issues of concern to the profession and to its members. At the local level, AIA components also express public concern through state legislative and governmental liaison programs.

Interpretations regarding the scope, direction or intent of an existing policy are made by the executive vice president

after conferring with AIA's president and reviewing recommendations of the government affairs department. Such interpretations must be presented to the board at its next meeting for confirmation or modification.

The following are among current AIA policies on public issues:

Practice

Three policy statements on liability were approved in December 1979. The first "strongly endorses" favorable tax treatment for professional self-insurance trusts (PLITE) and federal legislation to amend the Federal Tax Code to allow the deduction of self-insurance trust accounts as a business expense, placing such contributions on the same basis as insurance premiums. The second policy statement expresses AIA's encouragement and support of a test program on mediation "to provide for a simplified claims resolution system prior to litigation or arbitration" as an alternative to litigation or arbitration. The third policy "endorses and encourages the passage of state statutes of limitations on professional liability claims against architects and engineers."

Other policy statements with reference to the practice of architecture are:

Metric conversion: In December 1979, AIA's board approved a policy statement that supports the Metric Conversion Act of 1975 as related to the construction industry and further urges that the metric system be adopted as the national standard of weights and measures in the U.S. At its meeting in May, the board approved the conversion schedule developed by the American National Metric Council's construction industry coordinating council, setting Jan. 1, 1985, as the date when metric construction may begin in the U.S.

Architecture for recreation: In recognition that "open space and recreation facilities play a critical role in improving the quality of life," amended policy was approved in May that AIA "supports and encourages private and public policies and programs which provide for comprehensive long-range planning of urban and rural open

space and recreation facilities." Professionals and their associations should be used in the planning process, "with provision for citizen participation. . . ." Special attention should be given to inner city neighborhoods, the policy says, and government interagency cooperation should be encouraged to meet open space and recreational needs. The necessity for making new or renovated facilities contingent upon a "demonstrated financial plan deemed adequate for project maintenance and operation" is emphasized.

Barrier-free environment: AIA's policy, approved in December 1979, is to "continue to encourage and enlarge upon its efforts to create a totally barrier-free environment, not only in buildings but in the community generally."

Art in architecture: At its May meeting, the board approved a revision in its policy regarding the importance of public and private programs "in which an appropriate significant percent of a total architectural project [budget includes] art as [an] integral part of the project and its surroundings." The policy says that, further, AIA "supports mandatory application of percent for art programs by all government levels for construction and renovation of government facilities." Consideration for art "should be an early and integral part of the design process," with emphasis placed upon "the participation of local and regional artists." The kind of art and its placement should be determined by owner and architect, according to the policy, and no procedures should be developed that "add unreasonable or costly delays to the design and construction process."

Workers compensation: A policy statement approved in December 1979 says that AIA "endorses the amendment of worker's compensation laws to protect architects, engineers and contractors from third party suits brought by insured construction workers."

International practice: A policy statement approved in September 1977 and scheduled for review at the December board meeting calls for repeal of the changes made in the Tax Reform Act of 1976 which have resulted in "loss of employment, income and a competitive position for American architectural firms and their employees working abroad."

Tax revision: A related policy, also approved in September 1977 and due for review in December, expresses AIA's intention to continue work "to prevent passage of tax code changes which would decrease the opportunities for American design and construction firms to successfully compete in foreign markets."

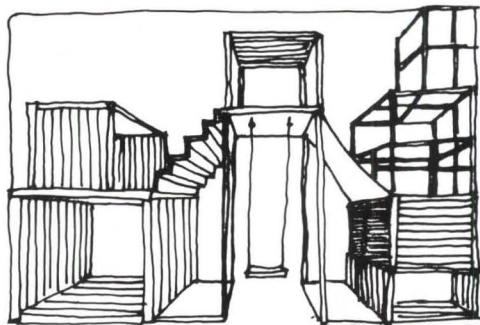

Illustrations by Carole Palmer

Summary of AIA Policies on Public Issues

Earthquake research: In the belief that "government-sponsored research in seismic response is in the best interest of the public," a policy statement approved in March 1977 and to be reviewed in December calls for AIA to ensure that architectural concerns are included in such research and gives support to efforts that will keep "government bureaucracy to a minimum in this research activity."

National Growth

There are nine strategies involved in the national growth policy that states: "The AIA supports changes in tax policy, governmental organization and other factors which shape community development; building and rebuilding at the neighbor-



hood scale; federal, state and local government coordination for special programs for areas impacted by rapid growth and deterioration." The strategies are based upon the "constitutional premises of open occupancy, equal opportunity and freedom to choose where and how one lives." These freedoms "may not" interfere with the freedom of individuals or damage the fabric of society (December 1979). A sampling in each category follows:

Population distribution: AIA says there should be a relatively equal distribution of low-, middle- and high-income persons in metropolitan areas; settlement from larger to smaller cities and economic and cultural opportunities for smaller cities, towns and rural areas should be encouraged.

Conservation: The policy seeks protection of fragile and/or unique *natural* areas, historic areas and buildings, air, water and food; conservation of irreplaceable raw material by use of alternative materials and new technologies; reduction of energy consumption; a more rational system of design and development of the land.

Fiscal: The strategy centers in public and private investment, tax reforms and identifying national productivity, consumption and employment targets.

Governance: The roles of various levels of government in implementing these

strategies should be identified to find a workable mixture of federal/state/local rule, the policy states.

Institutional: AIA supports the development of federal institutions to study national growth issues.

Land use: The Institute seeks a strategy designed to establish the "use and intensity criteria for accommodation of new and renewed neighborhoods," to preserve productive agricultural lands, to encourage the establishment of open space within and around urban areas.

Transportation: A more balanced transportation system should be provided by encouraging alternatives to the automobile, the policy states.

Design, development: Land should not be subdivided for housing alone, but have opportunities for shopping, employment and recreation, according to the policy, and encouragement should be given to mixed-income housing types in one community.

Urban rebuilding: Encouragement is given to regeneration of the physical fabric, the nonphysical systems and the public services within older inner cities and revitalization of central business districts.

Housing: The policy calls for incentives for development of relatively low-cost housing and for provision of direct subsidies for users.

Urban Affairs

The underlying thread of the Institute's urban policies is the need for the "nation to focus renewed attention on our cities." The resources of our cities—buildings, communities, local traditions—"must be conserved with care and continuously renewed to promote more workable and comfortable human environments."

Design: Encouragement is given to federal, state and local governments to "support urban design as an essential element in all policies and programs affecting our cities and communities." In addition, the Institute urges "that citizen interests be integrated into policies and decisions that impact them, and assure that the architect continues to play an integral role in urban design." The design policy is to be the basis for future policies on transportation, energy, regionalism, education, research, the small city and town. The board approved the policy in December 1979.

Growth: AIA encourages public acquisition of urban land for private development with designated use tied to long-range community growth plans, neigh-

neighborhood preservation, an equilibrium with the natural setting and a balanced population distribution. This policy was approved in June 1977 and will be reviewed in December.

Revitalization: Support is given to "programs combining private capital and public funding which would aid municipal government, reverse the cycle of physical deterioration and financial distress of American urban centers; target funding at neighborhood scale projects" (approved June 1977; to be reviewed in December).

Design centers: Because there "continues to be an inequity in the availability of design and planning expertise to low-income groups" and design centers have been successful in providing predesign services that have resulted in rehabilitation of housing and community facilities, AIA "continues its economic and moral support for the efforts of community design centers" (approved June 1977; to be reviewed in December).

District of Columbia: Separate policies call for a quick initiation of a restoration and maintenance program for the west front of the Capitol (approved March 1978); retention of the present height limitation in the city and that it be "embodied in an act of Congress" (December 1979), and support for the Pennsylvania Avenue Development Corporation's plan to revitalize sections of the city (December 1978).

Energy

The energy policies emphasize conservation through building modifications, use of renewable energy sources, use of passive solar energy design and active solar technologies. All were adopted in December 1979.

Conservation, solar: "All AIA members should promote conservation through passive energy designs that are not only cost effective but also that hold promise of long-term energy and economic benefit, whether or not governmental financial assistance is available." Encouragement is given to the use of all methods of energy conservation, including passive, active and hybrid solar systems. Realistic energy cost figures should be based on life cycle cost, the policy says.

Audits: "AIA recognizes that the nation's inventory of existing buildings offers opportunity for substantial energy conservation and this conservation can best be achieved by a total study of the functions housed and the interaction of all total building systems." The Institute therefore urges the Department of En-

ergy to recognize the role of architects and that architects should be authorized to perform energy audits.

Renewable sources: Calling other sources of energy that can fill the nation's interim needs, depletable, capital wasteful and environmentally problematic, AIA urges "intensified actions to eliminate



energy waste in buildings, through favorable tax programs and other means, and to dramatically shift [governmental] funding to accelerate the development of renewable sources of energy." This policy was prompted by the energy crisis, "which continues to accelerate in severity and impact beyond previous predictions."

BEPS: AIA strongly supports the building energy performance standards. Because of the "fundamental differences between performance and prescriptive standards," the Institute maintains that the two approaches "should not be considered equivalent."

BEPS implementation: "BEPS shall be rapidly promulgated and shall be mandatory in all jurisdictions throughout the U.S." AIA suggests a two-year phased-in implementation period for BEPS, during which time needed improvements can be made, workable standards produced and technical and administrative capacity established. During the two years, both building performance and component standards could be used with the latter eventually eased out. Designers would be required to provide an annual design energy use analysis prior to receiving a building permit.

Information: "The Institute should expand significantly the flow of information to the public and the profession concerning the opportunities for significant energy savings not only in new construction but also in existing buildings through conservation and related passive solar techniques."

Housing

The "importance of a good home as a necessity of life, as a sanctuary of the human spirit and a critical national resource" is the principle behind the Institute's housing policies. The policies were adopted in December 1979 and call for a "firm and unswerving national commitment" to provide quality housing. AIA believes that "good housing and good neighborhoods" make a vital contribution "to the general welfare of our civilization."

Goals: Among them are the conservation of our present stock of good housing, upgrading or replacement of substandard housing units and rejuvenation of slums and blighted neighborhoods.

Costs: Building requirements or standards that add to the cost of housing should be eliminated or streamlined, the policy says, and the cost of public facility infrastructure should be spread over a period of time so that the first occupants of new housing will not be penalized. Efforts should be made to increase the stock of affordable rental units, according to the policy.

Design, livability: "Increased emphasis should be placed on the important relationship of the physical environment to human well-being."

Mortgage credit: AIA recommends that federal policies and programs be designed to induce a steadier flow of residential mortgage credit and to maintain a level below which housing starts would not be permitted to fall.

Research, technology: AIA calls for the expanded research efforts in the area of residential environments. The Institute endorses federal expenditures for basic research devoted to advancing the state of the art of building construction, housing and the urban fabric; application of postoccupancy evaluation to improve long-range policy decisions; use of life cycle cost analysis and energy conservation, and use of renewable energy resources as important design criteria.

Subsidies: Support is given to the availability of housing subsidies for low- and moderate-income families for new, rehabilitated and existing housing.

Needed development: The Institute "urges that federal grants be provided to state and metropolitan planning agencies and to metropolitan-wide councils of governments to encourage them to undertake comprehensive land use planning, including housing components, and improve their institutional capacity to make and implement such plans."

continued on page 29

Designed by Haws for Wheelchair Users

These Haws drinking water fountains and electric water coolers help you to comply with Public Law 90-480 which states that facilities suitable for use by the physically handicapped must be available in buildings constructed, leased or financed by the federal government. Most of these Haws models feature two lever handles for left or right hand operation; wing handles available. Receptor which extends from the

wall provides a drink for everyone. Chilled water is available on Haws wall-mounted models.

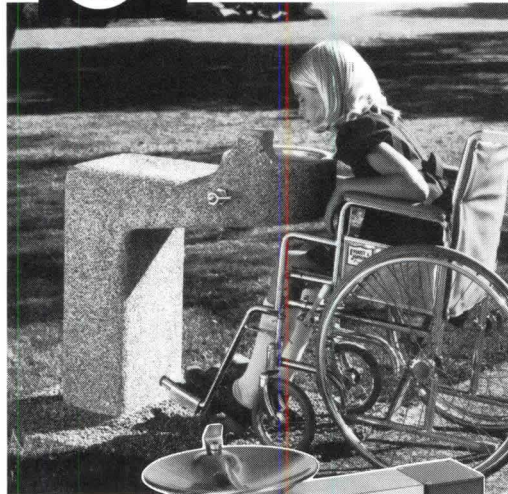

Model 1118



Model 1118BP



Model 1107



Model 3176
Vibracast reinforced concrete

Model HWC8
Water Cooler

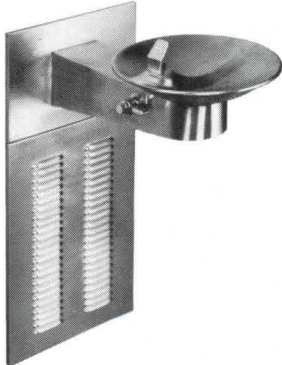

Model HWC8
Water Cooler

Model HWCL10
Water Cooler

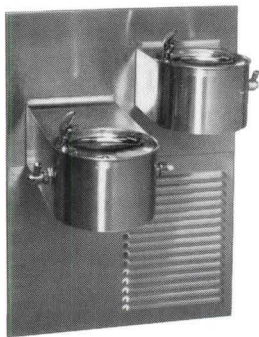

Model HWCD8
Water Cooler

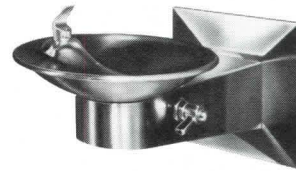

Model 1115BP



Model 1045
Precast stone



Model 1110
Available in stainless steel or bronze

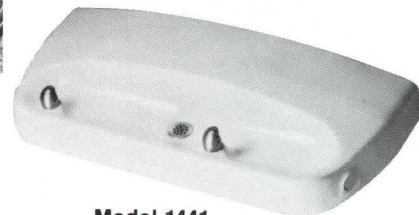

Model 1441
Cast aluminum with white epoxy finish

Model 3376
Stainless steel with epoxy coated steel pedestal



Model HWC10
Water Cooler

For catalog on these and other Haws models contact . . .



HAWS DRINKING FAUCET CO.
P.O. Box 1999
Berkeley, California 94701
Phone: 415/525-5801

NOTHING... That's Something!



Geberit gives you something new and exciting to think about...nothing. No visible tank. No protruding handle. No objectionable noise.

The incredible Geberit Concealed Tank System combines design versatility with built-in dependability. The tank is hidden in the wall, and easily accessible through the handy access cover. Now the bowl can be integrated into the total design concept. Couple this with Geberit's proven reliability, and it's easy to see the unlimited versatility of the Concealed Tank System. The tank is virtually unbreakable, non-aging, non-leaking, frost-proof and insulated. The entire system is backed

by an exclusive 10-year guarantee.

For more than 100 years, Geberit has been the industry's leading innovator throughout Europe. Now we bring this expertise to the architects and designers of America.

We invite you to explore these exciting concepts with us. Call or write for more information. We're certain you'll be pleased with what you see...and with what you don't see.

GEBERIT+

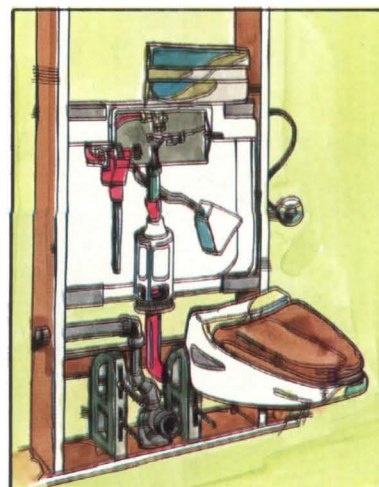

GEBERIT Manufacturing, Inc. • Michigan City, IN. 46360 • (219) 879-4466

Circle 18 on information card

Policies from page 26

Urban revitalization: The policy calls for a coordinated public and private conservation and renewal efforts. AIA supports channeling federal revenue sharing funds to the most distressed areas. In addition, "neighborhoods should be preserved through the maintenance, rehabilitation and adaptive reuse of deteriorating housing and other facilities. . . . Abandoned urban properties, because of their severely blighted influence on surrounding neighborhoods, should be improved and reoccupied or demolished."

Government

AIA's policies pertaining to government include generalized statements concerning the role of architects, A/E procurement procedures, federal design excellence, regulatory reforms. Other policy statements concentrate on specific issues, such as campaign finance reform and the Equal Rights Amendment.

Architects' role: AIA calls for the appointment of registered architects to executive and administrative government positions and the recognition of registered architects compared to nonregistered employees (December 1978).

Design excellence: "AIA realizes that it must constantly strive for design excellence and improvements in federal and federally-subsidized buildings." The key to improved design quality, says the policy, is a clear process of decision making. Encouragement is given to the use of public advisory panels in A/E selections; to the establishment by the President of an office or board with overall responsibility for design quality in federal architecture; to employment by the federal government of more design-oriented registered architects, and the establishment of a design awards program, among others (approved in September 1977; to be reviewed this December).

Regulatory reform: AIA will work with federal agencies to "reduce unnecessary or improper regulations." It will also testify before Congress against any policies, programs or regulations that are determined to be detrimental to the architectural profession and the public (December 1979).

Procurement: At its May 1980 meeting, the board approved a revision in government procurement policy. The policy, which gives support to the selection of architects and engineers for government work on the basis of professional qualifications rather than fee, also says that "unless the state has a better plan," AIA "further supports the adoption by state

and local governments of the American Bar Association model procurement code. . . ." Although recognition is given to the importance of having registered architects on government agency staffs, AIA "believes that architectural services

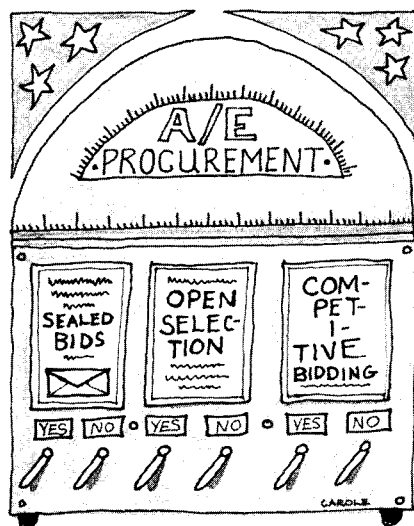

should be performed by private architectural firms." If it is necessary "to meet a government agency's special mission or requirement, architectural services may be performed by registered architects and their professional staffs of the respective government agency."

Value analysis: Maximum quality in federal construction and maximum value for every tax dollar spent can be achieved by "congressional encouragement of the use of value analysis in the early stages of the design process for federal construction." The basic goal of value analysis, according to the policy, is "to pinpoint the most effective, efficient design approach that will satisfy the facility's functional requirements based on established quality criteria and life span considerations" (December 1978).

Service contract: This policy, adopted in December 1978, is a reaction to bills introduced in Congress that would extend coverage of the Service Contract Act to any professional employees of federal contractors. The act ties wage rates for service employees working under federal contracts to prevailing or preceding contractor's rates. AIA believes that "legislation to have professional salaries under federal contracts set at prevailing rates or at some other level unrelated to individual performance would be detrimental."

Justice system: "AIA supports advancements in design, operations, performance systems and planning components relative to providing justice system facilities." Encouragement is given to including the

architect in the earliest planning and evaluation stages (December 1979).

Picketing: AIA opposes legislation allowing common situs picketing at construction sites. Such picketing, says AIA, could shut down the work of all contractors on the site, even those not involved in the dispute (December 1978).

Campaign finance reform: "AIA continues to endorse and support laws and legislation to reform and regulate political campaign financing." The Institute believes that public funding of congressional campaigns will "further insulate professional, public works decisions from improper influence and promote the ethical practice of the profession" (December 1978).

Equal rights: Support of the Equal Rights Amendment was reaffirmed in June 1979, and encouragement was given to all AIA components in unratified states to lend support to pro-ERA activities in their states.

National Endowment: Support is given to the National Endowment for the Arts in its efforts to preserve and encourage our cultural heritage. AIA supports reauthorization of Endowment programs at substantial levels (December 1978).

National museum: Support is given for the establishment of the National Museum for the Building Arts to promote and exhibit the building arts and sciences (December 1978).

Health Care

AIA has two policies in the health area: one on health care cost containment (December 1978) and the other on national health programs (December 1979).

Cost containment: "AIA supports life cycle cost effective capital expenditures." These include value analysis in building component selection; life cycle cost analysis in major building system selection; cost effective building materials, systems, construction techniques and project delivery methods; cost effective analysis of existing and proposed building codes and regulations and consideration of operational effectiveness as a primary design evaluation criterion.

National programs: "If a national health care system is established, AIA recommends a balanced method for the delivery of such care." The method would include short- and long-range comprehensive planning and reimbursement for costs related to health care, such as costs of long-range planning, saving or accumulation for the next project and the cost of manpower conserving equipment.

continued on page 32



Water table.

Keep this in mind next time you spec a roof.
The water belongs up there. Not down here.

Reason enough to specify Johns-Manville.
Because protecting what's under it is what a
J-M roof does best.

Why? Experience is one reason. Over 100 years
of solving roofing problems. Quality is another.
You can count on it in every one of J-M's
complete line of roofing products. Then there's

expertise. J-M's technical resources are
unmatched in the industry. And don't overlook
the unequalled coverage written into J-M's
Blue Chip guarantee program.

All this adds up to real protection. And that's
what a J-M roof is all about.

For details, consult Sweet's. Or contact Grant
Edmonds, Johns-Manville, Ken-Caryl Ranch,
Denver, Colorado 80217, 303/979-1000.

**Keeping the water out.
That's what this business is all about.**



Johns-Manville

Circle 19 on information card

The Environment

Many of AIA's public policies pertain in one way or another to the enhancement and protection of the quality of the environment. AIA has supported the National Environmental Policy Act since its inception, opposing any legislation that would lead to actions that would reduce the effectiveness of environmental laws and regulations supported by AIA policy. In December 1978, the board approved a policy that reaffirms its support of NEPA and endorses 10 recommendations.

Among them is a call for environmen-



tal impact statements to be "prepared and reviewed within an appropriate context of comprehensive planning and development policies." The policy urges that "environmental considerations . . . be integrated into planning and design processes. . . ." The statement also urges that "research, analysis, planning and design efforts of interdisciplinary teams begin at the formulative stage and continue in such a way as to make a maximum contribution to orderly creative processes of environmental design and public decision making."

AIA has also recognized that architects and other design professionals "are the prime movers in proposing or geographically delineating those large and small changes in the physical environment which affect natural systems" and has urged all architects to be concerned with both the primary and secondary effects of their proposals upon the natural environment.

Other specific policy statements include:

Water pollution: In furtherance of the goals and objectives of the Water Pollution Control Act amendments of 1972,

AIA reaffirmed in December 1978 its support of the implementations of the act and instructed the board "to continue to take such steps as will assist the President, Congress and the Environmental Protection Agency to reclaim the hygienic and environmental quality of our waterways."

Water resources: Also in December 1978 a policy was approved that calls upon AIA members "to exert leadership by alerting their clients to federal flood hazard boundary maps and data as to the human and material hazards and the potential environmental impacts of building in flood plains, and by assisting clients in seeking alternative locations for building projects." In the event construction in flood plains is undertaken, the architect is urged to "incorporate mitigating measures into both site development and building designs."

Land use: Those who hold land and those who are involved in determining the form and extent of this fundamental resource "share the obligation of responsible stewardship." AIA's policy, therefore, is to "encourage use patterns which are efficient in terms of resource utilization," improving the land's condition and capability for future use; to encourage "implementation of such land use patterns by means of rational, democratically formulated public policy"; to advocate a public policy framework at all levels of government; to support public policies that "further such concepts as diversity, citizen involvement, private economic incentives and public economic benefits," and to participate in the achievement of a "better public understanding in the area of intelligent land use." The policy, approved in December 1979, also calls for the construction of a "system of land use ethics as we increase our knowledge of the soil and its biotic community."

Surface mining: AIA supports the general intent of the Surface Mining Reclamation Act, legislation that establishes procedures for the administration of surface mining regulations to be implemented in general through state laws. "Federal statutes should also provide minimum criteria to be met by the states and localities for preplanning new areas to be surface mined, for monitoring and inspecting all surface mining operations and enforcing regulations regarding land rehabilitation." Among the other provisions of the AIA policy, approved in December 1979, is a call for states "which extract resources materially affecting one or more states" to form regional advisory committees "to consider appropriate cri-

teria for state laws and regional compacts." AIA members are urged to "become involved in the planning and analysis of surface mining as it relates to land use and the environment."

Coastal zone management: Recognizing that this country's coastal zone "is one of our greatest resources, capable of providing food, energy and many economic and environmental benefits," a policy approved in December 1979 urges AIA components in coastal areas to take an active role in the implementation of the Coastal Zone Management Act, which "clearly places the planning and management responsibilities squarely at the state level." The components should assist local entities "wherever possible, so that the maximum benefits can be achieved for their area. . . ."

Public domain lands: A policy approved in December 1979 states that the Bureau of Land Management (BLM) administers more land than any other private or public body in the U.S.—more than 700,000 square miles. These "left-over" public lands, in various parts, are rich in timber and mineral resources, support the sheep and cattle industry, are vital to the watershed system that supplies Western cities and contain vast areas of wildlife. "Above all, the BLM lands are the largest remaining uncommitted reservoir of public space available for the uses of generations of Americans yet unborn." But there exist "no legally recognizable policies or mechanisms for their use," which are critical in view of the increasing demands for recreational lands, the growing concern for environmental quality and the need to develop energy-producing resources.

AIA's policy sets forth recommendations for the acquisition and disposal of such lands, calling for an inventory and classification of priority uses. It points out that transfer to private ownership "is likely to be irreversible except at prohibitive costs. Where there is any doubt as to use priority or land suitability, therefore, land should remain in public ownership and any desirable private uses should be accommodated through leasing rather than through disposal."

The policy statement also calls for the development of "sound plans" that establish the priority of public use over private use. The long term should be considered rather than "short run uses responding to quickened cycles of market changes," and, in general, multiple use should take priority over single or dominant use concepts. Regarding legal authority and responsibilities, the policy

continued on page 37

TODAY'S GUARD.[®] THE ENDURING CLASSICS.

A classic never goes out of style, because it represents something so basically true that its appeal is timeless. Like the new Guard[®] vinyl wallcovering collection, perfectly at home in rooms generations old, or in the sleekest, most contemporary superstructures. Ask to see the Guard sample book, with 35 designs and 808 colors in Type I, II and III materials. There are 14 brand new designs and the broadest palette of today's colors in the industry. Designs of simplicity, classic style that will endure for years of care-free use. Columbus Coated Fabrics, Columbus, Ohio 43216.



GUARD[®]
VINYL WALLCOVERING

Circle 20 on information card



Otis Introduces

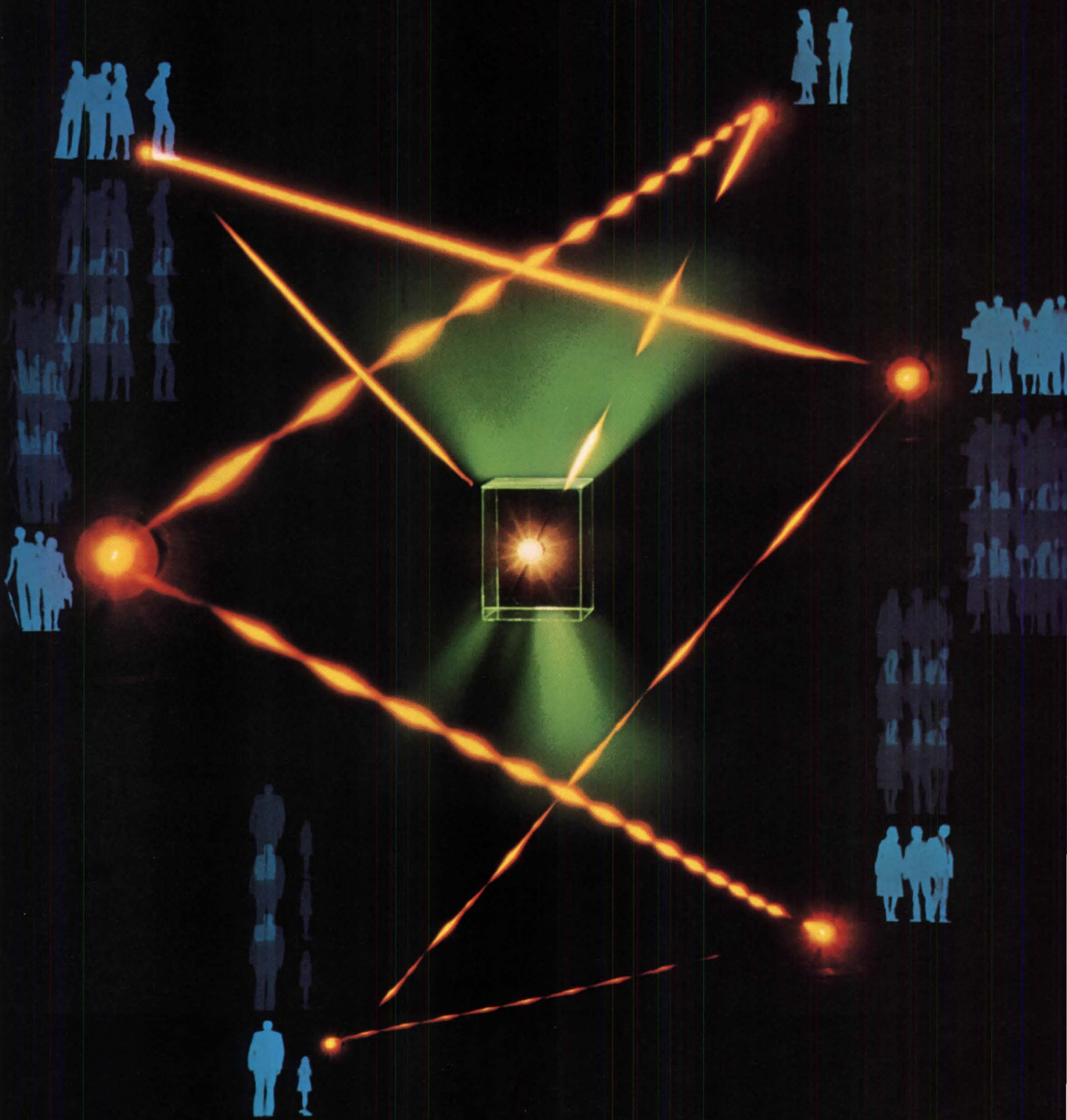

Elevonic 101...

A step into the future that saves time, energy and money.

Revolutionary in concept and designed using the latest elevonics* technology to provide the most economical operation, the new Otis Elevonic 101 microcomputer elevator control system vastly improves passenger travel time, reduces installation and adjustment time, conserves substantial quantities of energy and improves reliability.

New Generation Microcomputer

Otis HR gearless elevator systems, equipped with Elevonic 101 controls, can, for the first time, computer-control every aspect of elevator operation—velocity, position, direction, passenger travel and waiting time, door operation, car assignment in a group, energy usage and system diagnostics. Truly a new generation of elevator control—unmatched by any other system available.

Demand-Response Operation

The Elevonic 101 is unique among elevator control systems. It is the only system that can instantly and precisely react to actual traffic demands all of the time.

It's software based, so it can be easily reprogrammed without replacing expensive hardware if a building's needs change. The result is unequaled performance and passenger convenience and comfort coupled with outstanding operating efficiency.

Average passenger waiting time can be as much as one third less than our best previous equipment.

Energy-Saving SCR Drive

Silicon controlled rectifier (SCR) motor drives use about 30 percent less energy than motor generator sets. They use no power at all when the elevators are at rest. That means improved energy management and lower building operating costs.

Precise Floor Landing Stops

Elevonic 101 eliminates the large electromechanical position selector. A solid state transducer system measures car hoistway position to within 1/32" and provides continuous, dependable leveling accuracy. And, it automatically compensates for building compression.

Reduced Installation Time

The exclusive software-based controls are simulated, tested and adjusted prior to delivery. Total installation and adjustment time can be reduced by as much as 20 percent. And that's not all.

Multiplexing—transmitting several signals simultaneously over a single wire—has reduced traveling cables from an average of three cables, each carrying about 70 wires, to a single cable with about 50 wires, further reducing installation time.

These are only a few of the major improvements that elevonics has enabled us to engineer into our new Otis HR gearless equipment. Others include reduced machine room space, smoother, faster door operation, reduced elevator downtime and additional ways to maximize energy efficiency.

We've given you just part of the Elevonic 101 story. For the full story on the Elevonic 101 control system, call your local Otis office to see how it can save you time, energy and money on your next project.

***Elevonics is the science of moving people and products through the use of advanced elevator and microelectronic technology.**

OTIS ELEVATOR COMPANY
Subsidiary of
UNITED TECHNOLOGIES

Circle 21 on information card

ROMANY® VINTAGE

Introducing a new, finely-textured, glazed ceramic tile superbly styled in warm, earthtone colors.

The newest addition to our collection of distinctive ceramic tile designs, Romany Vintage tile provides a soft earthen elegance. For that rich, warm, closer-to-nature look, Romany Vintage colors include walnut, cork, white, butternut and almond.

Ideal for interior residential floors, walls, countertops and back splashes. It can be used in kitchens, baths, entryways, dens and study rooms.

Available in 6" x 6" and 3-5/8" x 7-5/8" sizes, this 3/8" thick glazed tile has a dense body with less than 3% absorption. Romany Vintage may also be installed on exterior wall surfaces.

For details contact your nearest Romany-Spartan stocking distributor in the Yellow Pages. Or write United States Ceramic Tile Company.



United States
Ceramic Tile
Company

Subsidiary of
Spartek
Inc.

1375 Raff Road, S.W.
Canton, Ohio 44711

Circle 22 on information card

Policies from page 32

calls for BLM to be given "the power to classify lands for specific uses rather than having to rely upon withdrawal, the power of policing all lands under its authority and the power to institute and enforce controls over lands released to private ownership."

The policy states further that "legislation and management programs should clearly spell out the goal of protecting and promoting overall environmental quality on the public lands," including not only the maintenance of physical productivity, but also "the preservation and enhancement of visual, social, historical and cultural values." In the program of land inventory and classification, distinction should be made between lands on which grazing might be the best use and those which could be used for grazing but are also critical in such public goals as watershed protection. "A more adequately staffed, funded and enforced program of range control and revegetation is needed, as is expanded research on the relationships between vegetation growth, soil and moisture conditions, and a complex variety of grazing practices upon which such a program must be based."

The policy addresses mining/mineral extraction, saying that "the federal government should have the absolute right to determine when, where and under what conditions mining shall be permitted on the federal land."

Tallgrass park: In December 1978, AIA endorsed a proposal for a tallgrass prairie national park in Kansas "to ensure that this important area of the national and historic heritage be preserved for future generations."

Indiana dunes: Within a 100-mile radius of the Indiana dunes national lakeshore, about 10 million people live and work. Located in northern Indiana, the area is a "unique combination of botany, wildlife, geography, natural history and beauty and outdoor recreation." After more than 50 years of effort for the preservation of some of this "priceless land," Congress authorized in 1966 the creation of the Indiana dunes national lakeshore with the purchase of 5,300 acres, to which some 4,000 acres were added in 1976. Yet, there are still "some unique areas intrinsic to the dunal region" not represented. In a policy statement approved in December 1978, AIA urged that lands also be obtained "to meet the recreational needs of this rapidly growing urban area" and to serve as buffer zones "to prevent further abuse and destruction."

Highway beautification: AIA, in the past, gave support to the Highway Beautification Act of 1965. Since its passage, "the law has been so amended and changed as to reverse its effect, making billboards a form of federally protected land use and preventing state and local governments from enforcing their own control ordinances." In March 1978, policy was approved that gives support to the provisions of the act as passed originally. The policy also recognizes "beautification as an integral part of the design process" and supports the financing of the highway beautification program from the Highway Trust Fund.

National park access: Scheduled for review at the December meeting of the board, a policy approved in 1977 supports, in principle, the provisions of transportation services to entities of the national park system in order to make the parks available to all people.

Timber resources: Also to be reviewed in December is a policy, passed in 1977, that calls attention to the "inefficiencies and wasteful practices in the processing and use of timber resources." AIA supports improvement in the management of national forests, increased production of private forests and protection of wilderness areas.

Alaska lands: In policy approved in September 1979, AIA stated its support of the Alaskan Lands Conservation Act of 1979 which provides for the planning, classification and control of lands in order to preserve for the future those lands of primary wilderness value. AIA recently expressed its support of amendments to legislation currently being debated in Congress (HR 39), to protect the lands subject to possible energy development.

Codes and Standards

In the past, building construction regulations have often resulted from response to a catastrophe. Such response is not always carefully thought out, and "often there was a mismatch between the enacted code and the intended result." Or even worse, misapprehension of the problem resulted in "needless regulations." AIA's policy on the purpose of codes and standards, approved in December 1979, is directed toward preventing the situation in which codes and standards become "unduly restrictive in their requirements because some special interest has been able to influence the drafting and the adoption of them in its exclusive favor." AIA supports the concept that codes and standards must be "based upon proven public need, satis-



fied by rationally conceived criteria, without favoritism or bias to any special interest and cost effective in relation to public benefit."

Adoption process: AIA "encourages the mutual participation of public and private sectors in the adoption of statutes, regulations, codes and standards that govern the construction of buildings through the procedures of due process." Due process includes "timely and adequate notice to all interested parties and an appeals procedure for all who may be injured." AIA recognizes "that due process has always been appropriate when laws are enacted and, in most cases, has been followed." Due process "deserves special treatment since currently consumer groups and the federal government are attacking the procedures by which codes and standards are conceived and enacted into law."

Appeals: AIA "encourages the use of codes and standards which provide for an appeals procedure for all who might be injured."

Central authority: AIA supports "the concept of a central nongovernmental entity, bringing together the private sector with the various levels of government, as an authoritative national source of information on building science and technology for the purpose of (1) bringing about needed change and harmony in codes and standards development; (2) developing a rational relationship between building technology and codes; (3) bringing about needed research, and (4) acting as a clearinghouse for technical data on building construction."

Consensus process: AIA encourages the use of the consensus process in the development of codes and standards. "This process has at least five elements: groups

continued on page 40

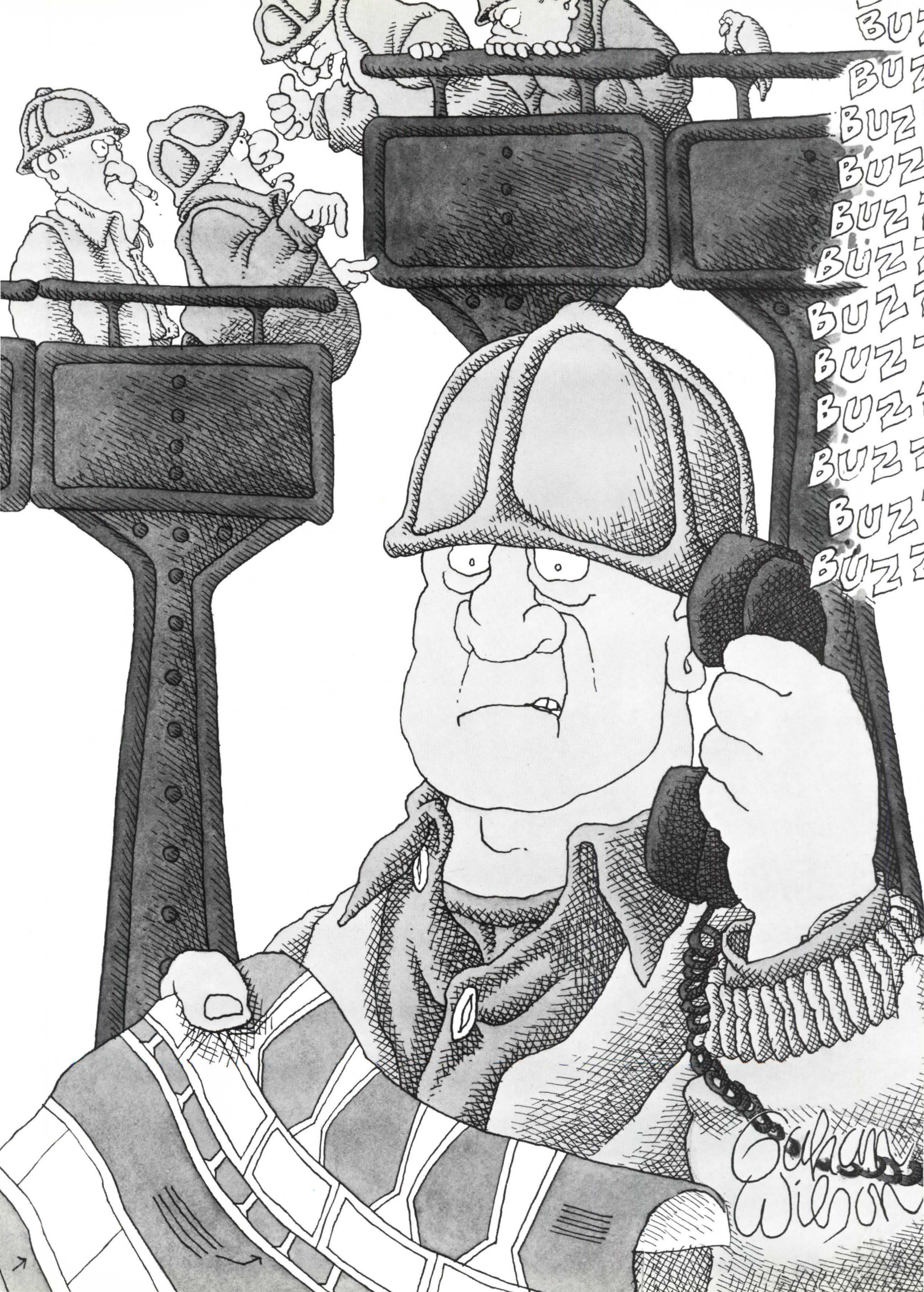

BUZZ
BUZZ
BUZZ
BUZZ
BUZZ
BUZZ
BUZZ
BUZZ
BUZZ
BUZZ

Stephen
Wilson

Is solving problems a problem because you can't be reached?



The Bell System has a way important calls can reach you when your regular lines are busy.

When somebody calls from your job site with a problem, that's no time for all your lines to be busy. You've got to be available.

If you're not, you end up losing valuable time. And that makes it harder for you to make a profit.

What you need is an effective communications system. That's where your local Bell company can help your business.

Both the Com Key* and Horizon® communications systems by Western Electric feature a personal line that goes directly to your office. It's an open line that can make your business more profitable by keeping you accessible. With it you'll always be assured that important calls get through. This can save you time by enabling you to handle problems efficiently. And whoever you give your private number to will *always* have a way to reach

you—quickly and easily.

Should *you* find the need to make an important call, you'll always find the personal line open.

Saving time and money

Western Electric Com Key and Horizon systems can help your business in many ways. Suppose you're in the office but away from your desk when an important call comes in. With the paging feature on a Com Key or Horizon communications system, your secretary can call you in almost any part of your office over the paging loudspeakers. No shouting down the hall or wasting time tracking you down.

To stay on top in your business you have to complete your projects on time. And that means using your phone to coordinate job information. That's where conference calling[†] comes in handy. It lets you speak to several people at one time, at the touch of a few buttons. You can consult with your client, an associate, and a contractor at the same time. That saves you time and needless callbacks

because you confirm information quickly and accurately.

Giving your client the best service

When your client is considering an important proposal, it's essential that he be able to reach you to discuss any details. If you're out of the office when he calls and your secretary has the number where you are, she can call and connect you instantly with the client.

If you're preparing a proposal, you can't waste time running back and forth to your library looking up zoning information. With the Com Key or Horizon system's intercom, you can call your associate or consulting engineer simply by pressing a single button. That way, you can keep right on working—without interruption.

Tailored to your needs

There are even more ways Western Electric communications systems can make your business more efficient and profitable.

Your local Bell company can tailor a communications system to your needs—no matter what size your business. And they back every system with prompt, dependable, experienced service.

So call your local Bell company today.

You'll end up with more than a better business communications system.

You'll end up with a better business.



*Trademark of AT&T.

Western Electric

†Note: Voice quality may decrease depending upon the distance between conferees and the number of persons on the conference call.

Circle 23 on information card

Policies from page 37

representing broad experience and balanced viewpoints, periodic reviews, appeals procedures, opportunities for all affected parties to participate and careful attention to opinions, including minority opinions."

Consistency: Design professionals and others concerned with codes and standards are encouraged "to exercise consistency in the development, adoption, interpretation, enforcement and application of the various codes and their referenced standards." A policy regarding consistency is needed because an architect's practice is not confined to one political jurisdiction. "To be entangled by the inconsistent codes and their provisions causes the loss of valuable effort and money and, in the end, is a hindrance to the free exchange of commerce. Harmony among codes is essential to protect the public's right to expect an equal level of treatment wherever it transacts business."

Education: "To ensure that codes and their referenced standards exhibit the highest degree of quality in their development, adoption, interpretation, enforcement and coordination, AIA encourages the education of students of architecture and the continued education of architects in the fundamentals of codes and standards, and the continued education of building, zoning, health, fire and other governmental officials who are concerned with the administration of codes and standards. . . ."

Enforcement: AIA "encourages the enforcement of codes and their referenced standards at that level of local government that can support competent personnel and their training."

Governmental development: All levels of government are encouraged to participate with the private sector in the development of codes and standards through the use of the consensus process.

Participation: AIA "seeks to strengthen the collective voices of all design professionals in the development and use of codes and standards pertaining to the construction industry by encouraging their participation in this process and by coordinating their activities through the establishment of public policies."

Performance criteria: AIA "encourages the development of codes and standards based on performance criteria. Performance criteria, however, should not be used in place of prescriptive requirements, where limitations of technology make it impractical and the cost of such efforts exceeds the benefits."

Research: AIA supports and encourages research required "to establish scientific

data to augment the development of codes and standards."

Review: AIA "encourages periodic review and revision of all codes and their standards in order to incorporate improved technology, to eliminate obsolete provisions and to eliminate cumbersome and confusing wording."

Historic Preservation

Historic preservation is defined as "the process of conserving for future generations the significant elements of the built environment." The process extends beyond traditional restoration to include documentation, stabilization, reconstruction, rehabilitation, adaptive use, maintenance, interpretation and compatible design.

The preservation of historic resources "deserves high priority among the nation's programs and goals." In order to achieve this national goal, AIA's policy embraces the following elements:

Landmarks: AIA supports landmark legislation "to preserve and/or guide the development of structures or sites with historic, cultural, architectural, archeo-

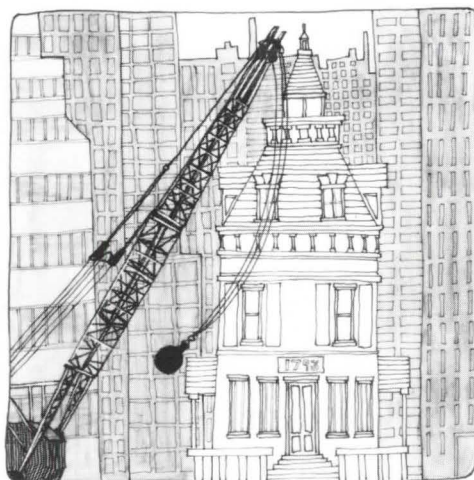

logical or esthetic significance." Each landmark "should be evaluated by a public body that finds a consensus as to its merit and methods by which it can be self-supporting or properly endowed."

Neighborhoods and districts: Support is given to the preservation of neighborhoods of social and cultural value and to programs that maintain the community's fabric by such means as the improvement of deteriorating structures, with "minimum or no displacement. . . ." New buildings in older neighborhoods should be designed in a manner that is "both sensitive and original," but also compatible with the existing neighborhood.

Incentives: AIA supports "continued development and expansion of federal,

state and local programs, grants and tax incentives supportive of preservation."

Codes and zoning: Encouragement is given to the "adoption and creative application of codes and zoning regulations supportive of preservation." Further, there should be "sensitive and considerate applications" to make historic properties barrier-free in a manner that "maintains important design features."

Architectural records: AIA supports "the creation of a national clearinghouse for architectural archival material" and further supports "the development of regional depositories to collect, conserve and catalog original architectural documents." The continuance of the agreement among AIA, the Library of Congress and the Heritage Conservation and Recreation Service of the Interior Department is also supported in order to ensure the expansion of the Historic American Buildings Survey.

Education: AIA "supports the introduction to the public of architectural preservation through formal and informal programs," encourages schools of architecture "to include education in architectural preservation as an objective" and "urges all architects working in the area of architectural preservation to increase their knowledge in this field through continuing education."

The nation: From time to time, the board will desire "to make a statement on a particular building or preservation issue which is deemed by the architectural profession to be of crucial national importance. This policy is intended as a repository for these statements, which should remain in effect until modified or withdrawn by the board."

1. AIA endorses the establishment of the Frederick Law Olmsted home and office in Brookline, Mass., "including original drawings and other records of this master landscape architect, as a national historic site." (1974).

2. AIA supports the "maintenance and integrity of the original design of the Lincoln Memorial" in Washington, D.C., and recommends "that changes in the composition of the Republic be recognized by means other than additional inscriptions on the Memorial walls." (1974.)

3. AIA supports the preservation of Grand Central Station in New York City and the "continued validity of landmark preservation laws as upheld by the Supreme Court in 1978 (Penn Central vs. New York City) on the basis of police power rather than the power of eminent domain." (1978.)

The amended policy on historic preservation was approved by the board at its meeting in May, 1980. □

The most beautiful part of this wall is the part you can't see.

Colorline's new 3.75 NEF[®] movable wall system has a hidden beauty that meets the demands of modern interior design. It's our patented "NEF[®]" feature: No Exposed Fasteners. That means no more unsightly screwheads, rivets or other visible fasteners. Just a beautifully smooth, clean wall surface with superior sound control. And available in 24", 30" and 48" panel widths, in your choice of more than sixty decorative coverings!

Discover the hidden beauty of the Colorline[®] 3.75 NEF[®] wall system today. It's one of four economical pre-engineered wall systems, with matching doors and hardware, available from the Colorline[®] distributor in your area.

UNISTRUT

Interior Building Systems

GTE

GTE Products Group 1821 Bedford Avenue North Kansas City, MO 64116
Toll Free 1-(800) 821-5724 (816) 421-4011 in Missouri

Circle 24 on information card

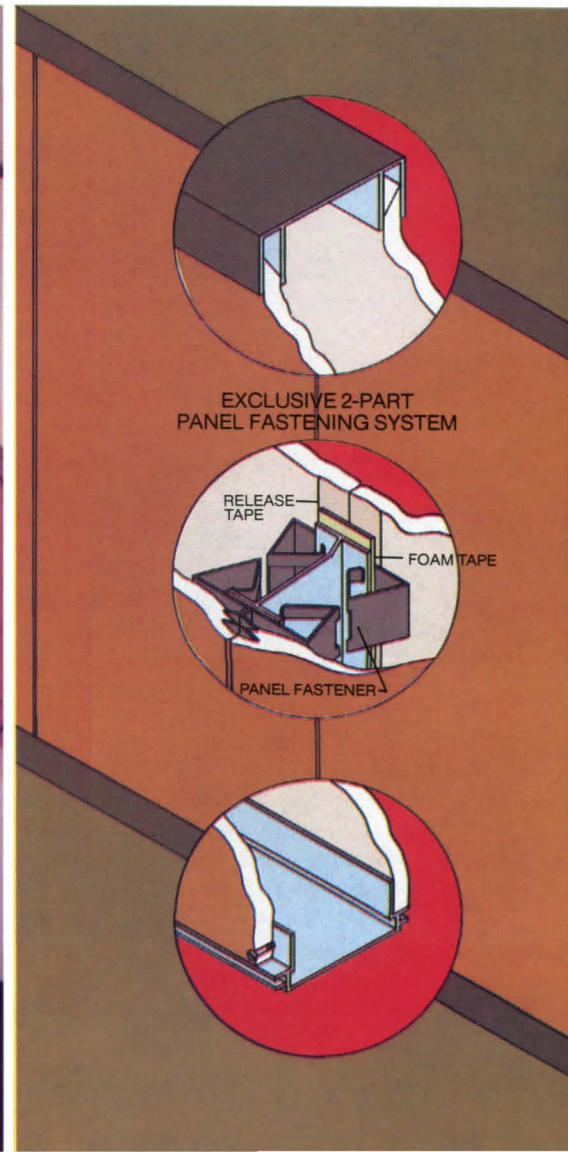

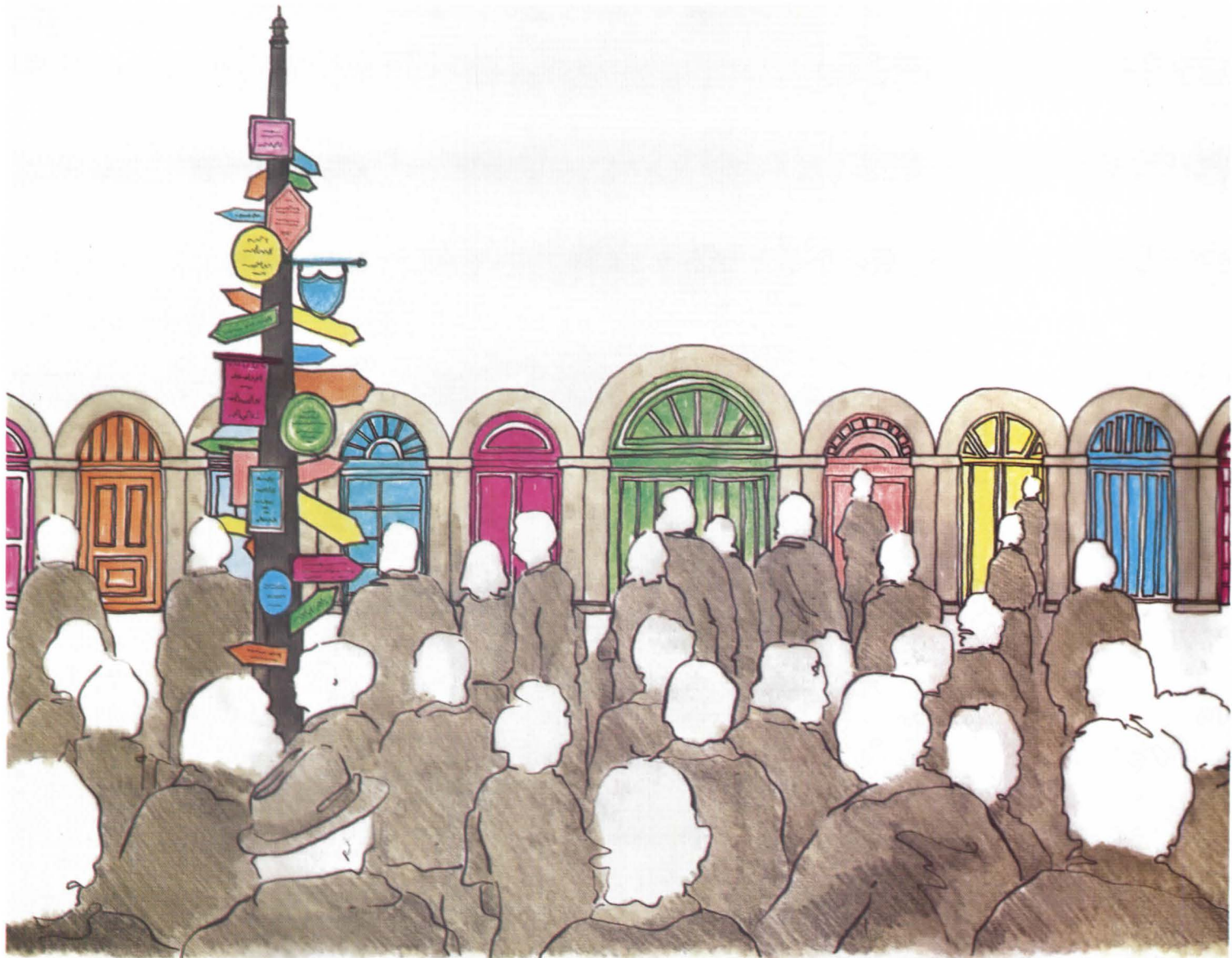

CAROLE PALMER

The Workings of the AIA Committee System

It involves an increasing number of members. By Nora Richter Greer

AIA members can pursue their special interests and at the same time affect Institute policy and programs through the AIA committee system. The committees study a broad range of specific topics related to the practice of architecture, develop practice tools, define issues and make policy recommendations.

Until recently, the committee system consisted of groups with limited membership. Under this "closed" system, committee members were appointed by the board upon recommendation of regional directors or committee members. But beginning in 1978 the committee structure has undergone extensive reorganization. First,

membership of the nine professional interest committees (architects in industry, historic resources, housing, interior architecture and architecture for commerce and industry, education, health, justice and the arts and recreation) was opened to all AIA members. By opening these committees, the board hoped to broaden membership involvement and draw more broadly upon AIA members' talent, which the board maintained was not being successfully tapped by the "closed" committee system.

The next reorganizational step was for the nine professional interest committees to welcome corresponding memberships.

For a fee (\$9 per year/per committee for AIA members, associate members, AIA chapter professional affiliates and ASC/AIA members; \$15 per year/per committee for all others) corresponding members receive all notices, meeting minutes and reports of the committee and can participate in any committee activities. Each of these committees has a chairman and a five-member steering group. One can become an open committee member simply by attending two meetings during a two-year period. By the end of 1979, there were 810 corresponding memberships. As of April '80, the number had risen 19 percent to almost 1,000.

These open committees proved so successful that last year AIA expanded the concept to 13 other committees, although without the corresponding memberships. (The 13 open committees are: architects in education, architects in government, codes and standards, community assistance, continuing education, design, energy, environmental education, federal agencies, minority resources, practice management, regional development and natural resources, and urban planning and design.)

Opinions vary as to whether opening these committees has been successful. Some maintain that it has made access to committees easier because an interested member doesn't have to go through a formal process to become involved in committee work. Supporters of the system also say that it has allowed for greater flexibility within each committee. But others maintain that the open system yields unwieldy groups, making it difficult to accomplish specific tasks. Often the steering committee takes over the task-accomplishment while the open meeting becomes a seminar. And, some say, the new system doesn't seem to be attracting more attendance because members are reluctant to pay their own expenses to attend out-of-town meetings. And, unless meetings receive a lot of advance publicity, some say, the new system is not even attracting increased local attendance.

The remaining "closed" committees meet formally one to four times a year. They cover a broad range of professional issues such as the Institute juries, international relations, finance, documents, liability and practice management. As with any committee system, productivity depends upon the chairman and the members and their clear understanding of the tasks. Each committee's function varies from overseeing the work of the AIA staff in a particular field to taking more of an advocacy position. A small sampling of committee work follows.

- Called the Institute's "lobby for urban design" by chairman Gary A. Plosser Jr., AIA, the urban planning and design committee's task is to increase architects' participation in solving urban design problems of towns, cities and metropolitan regions. "The committee," said Plosser, "is made up of a number of very dedicated people who think their work is important . . . who feel that architects need to be concerned with the built-in context of the city."

Last year, the committee presented to the AIA board of directors an urban design policy, which is now being circulated to other committees for further input.

Currently, it is developing a transportation policy, which Plosser hopes will be ready by the end of the year. The policy will be concerned with the relationship between

Urban planning and design: formulation of public policy statements using assistance teams as a 'testing ground.'

transportation systems and the physical environment. The committee is also developing an Institute urban design awards program, working on continuing education programs and planning to present a major program at next year's convention in Minneapolis.

The "testing ground for the committee's current thinking about urban design techniques and issues," in the words of Plosser, are the Regional/Urban Design Assistance Teams (R/UDATs). R/UDAT programs are directed by a task force, but the ultimate responsibility lies with the committee. This year R/UDATs have been or will be held in the south end of Boston; Salisbury, Md.; Duncan Plaza, New Orleans; Louisville; Lincoln, Neb.; Hillsboro, Ore.; Wilmington, Del., and Topeka, Kan. A study of R/UDATs and their effects on a number of cities is being prepared by the committee funded by a grant by the National Endowment for the Arts.

- The A/E committee on federal construction is actually a liaison group that provides a forum for representatives from AIA, the American Consulting Engineers Council (ACEC) and the National Society of Professional Engineers (NSPE) with federal officials whose work involves construction. The architects and engineers meet three times a year with representatives from such agencies as GSA, the Environmental Protection Agency, HUD, the U.S. Postal Service, the Veterans Administration, the Department of Defense, the Department of Energy and the Department of Health and Human Resources. The meetings allow the chance to air problems and to find out what is happening in the various agencies.

- Also dealing with government affairs is the Committee on Federal Procurement of A/E Services (COFPAES). This is also a joint group representing AIA, NSPE, ACEC, ASCE (American Society of Civil Engineers) and ARTBA (the American Road and Transportation Builders Association). The committee's purpose is to develop and advocate legislation and administration action enabling architects and engineers to provide the federal govern-

ment with the highest quality of services consistent with sound professional standards. COFPAES, represented by R. Randall Vosbeck, FAIA, testified at Senate hearings on the new legislative charter for GSA's public buildings program (see Mar., p. 12, and May, p. 31).

- The professional development committee advises on the identification, development, delivery and evaluation of continuing education program for AIA members. It oversees the work of five subcommittees: convention programs, programs (professional development, associate and internship development programs), futures, educational policy and programs controls.

The committee developed and reviewed 23 professional development seminars that were presented at the AIA convention in Cincinnati. It plans to issue two new architectural training labs in the fall (financial management and time management) and is working on three correspondence programs (two on energy and one on financial management). One of its major projects is to develop a computerized registry service for continuing education units.

- Taking a leadership role in the preservation, conservation and integration of America's architectural heritage and its historic resources is the task of the historic resources committee. The committee monitors and makes recommendations on codes, such as the HUD rehabilitation standards, works with the committee for preservation of architectural records,

A technical base for historic preservation and a primer on techniques of project delivery.

suggests programs for preservation education and develops publications. The committee is currently developing a publication with technical preservation information, similar to *Architectural Graphic Standards*. It is watching the work of the Historic American Buildings Survey. The survey is of "practical interest to architects," says committee chairman Harvie P. Jones, AIA. "They can use the documents for restoration and historical research."

Members of the committee testified in two separate hearings before congressional committees, in the spring, calling for the strengthening of historic resources through the development of new strategies and for increased funding for preservation programs, consistent with today's federal

continued on page 46

IF YOU THINK ALUCOBOND™ MATERIAL IS GREAT FLAT OUT, WAIT TILL YOU SEE HOW IT TAKES



The building on the left is an example of what ALUCOBOND material doesn't do.

Namely ripple, buckle, or bulge.

Thanks to this remarkably flat composite of two aluminum sheets and a thermoplastic core, oil-canning has been totally eliminated on Kubota Tractor's streamlined U.S. headquarters in Compton, California.

The building on the right is an example of what ALUCOBOND material does do.

Wrap around corners in sinuously graceful lines.

The incredibly smooth curves and uniform color of this Consolidated Aluminum product help create a beautiful first impression for Trailer Life Publishing Company in Agoura, California.

Available in six siliconized polyester resin colors and four handsome

When Daniel Dworsky, FAIA, of Daniel L. Dworsky FAIA and Associates, Inc., selected ALUCOBOND material, a key consideration was the easy expansion it permits.



THE CURVES.

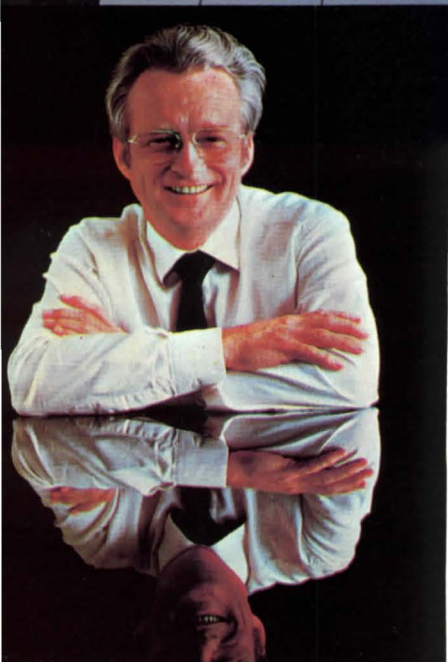

anodized finishes, ALUCOBOND material comes in panel sizes up to 5' X 28' and thicknesses of .118", .157", and .236" (3, 4, and 6 mm).

And its extraordinary adaptability offers architects design possibilities as diverse as their imaginations.

To find out more, call our Marketing Manager, Carla Lane, at (314) 878-6950. She can provide you with samples and

Jerrold Lomax, AIA, of Lomax-Mills-Architects, shares credit for his creative use of ALUCOBOND material with Project Architect John Rock.

information on ALUCOBOND material. The innovative product that's smoothing the way for creative architects everywhere.

Turn page for distributor listing.



Circle 25 on information card

Committees from page 43

budget realities (see May, p. 31).

- The construction management, design/build and contracting committee is preparing a primer on project delivery techniques to help architects who are beginning to expand the nature of their services to include construction management. In conjunction with the primer, it hopes to develop a construction management program for the '81 convention. "This is an important area where AIA should have publications," says chairman Jonathan King, Hon. AIA. One of the committee's problems is acquiring funding adequate to develop publications, which King attributes to "the economic problems of the Institute."

The committee also represents AIA on the Joint Conference on Construction Management, whose other members are ACEC and the Associated General Contractors of America, Inc. (AGC). The joint conference "hasn't been meeting as regularly as it should," says King. This is due to disagreement among AIA, ACEC and AGC about the role of construction managers. AIA maintains that a conflict

doesn't arise if an architectural firm expands its work on a project to include construction management. AGC maintains that architects should not practice construction management.

- The practice management committee is a "work-oriented group," says Robert Allan Class, AIA, the committee's staff executive. Its task is to develop programs and activities in office and project management, with emphasis on the needs of small and medium-sized firms. The committee is working on the *Project Managers Workbook*, written by David S. Haviland. The book will be published in four sections: "Project Management" is in final form and "Project Management in the Architect's Office" will be available in October; "The Effective Architectural Project Management" and "Tools and Techniques for Architectural Project Management" are scheduled for publication in 1981.

In Savannah, Ga., on Nov. 13-14, the committee will hold an open meeting seminar on managing a practice in a recession. Next year it will hold two meetings in Washington, D.C., to develop practice aids and a conference in Chicago

on architectural management.

Task forces are generally formed to address specific issues for a year or two; then they are either disbanded or transformed into committees. Current task forces are concerned with women in architecture, long span technologies, legal decision impact, IDP evaluation, uniform construction index, among others.

The registration law advisory task force was formed in response to the increasing number of state sunset laws that require review of architectural registration boards. The group is studying the gamut of matters involved in architectural registration: its history, license renewal, legislative guidelines, the definitions of architects and architecture, educational requirements, regulatory boards and reciprocity.

It will publish an analysis of registration laws, a preliminary report on architectural registration, "Issues and Options," and guidelines and strategies for obtaining legislative policies. In an effort to bring the registration debate to a national level, it conducted discussion sessions highlighting registration issues at the '80 grassroots meetings. □

WHEN YOU WANT TO USE ALUCOBOND™ MATERIAL, THESE DISTRIBUTORS WILL SMOOTH THE WAY:

NORTHEAST

Adammetal Supply
Elizabeth, NJ 07207
(201) 351-2550

A.O. Stilwell Co., Inc.
Buffalo, NY 14224
(716) 828-1415

B.R. Johnson, Inc.
Syracuse, NY 13057
(315) 437-1070

Building Specialties
of Pittsburgh
Pittsburgh, PA 15209
(412) 821-5310

Custom Walls and Windows
Kensington, MD 20795
(301) 949-6550

Eastern Metal Mill Supply
Dedham, MA 02026
(617) 329-1200

The Fox Steel Company
Orange, CT 06477
(203) 799-2356

Frank N. Henry, Inc.
Wilkes-Barre, PA 18703
(717) 824-4611

Fred Boschan Co., Inc.
Philadelphia, PA 19127
(215) 483-8000

Metal Construction
Services, Inc.
Baltimore, MD 21218
(301) 949-6550

SOUTHEAST

Attaway & Howell Co., Inc.
Tucker, GA 30084
(404) 938-7830

Delph-Context, Inc.
Charlotte, NC 28201
(704) 376-3671

Demarest Company, Inc.
Oneco, FL 33558
(813) 758-3811

Fletcher & Associates
Birmingham, AL 35203
(205) 328-0525

J.M. Power Company, Inc.
Trenton, MI 48183
(313) 479-2200

John W. McDougall Company
Nashville, TN 37209
(615) 383-4036

Penco, Inc.
Louisville, KY 40204
(502) 584-1166

W.H. Stovall & Co., Inc.
Ashland, VA 23005
(804) 798-1415

MIDWEST

Casewin, Inc.
Minneapolis, MN 55416
(612) 545-1635

Condit Construction Products
Dayton, OH 45409
(513) 298-9922
Columbus, OH 43228
(614) 274-2283
Cincinnati, OH 45229
(513) 242-4029

Jones and Brown Co., Inc.
Addison, IL 60101
(312) 543-0300

Karl M. Block Co., Inc.
St. Louis, MO 63144
(314) 647-8044

Swanson Gentleman Hart, Inc.
Omaha, NB 68154
(402) 493-9393

Swanson Gentleman, Inc.
Des Moines, IA 50309
(515) 244-0186

WEST

Associated Specialties Co.
Salt Lake City, UT 84106
(801) 487-8501

Elward, Inc.
Denver, CO 80223
(303) 936-7201

Payne & Howard, Inc.
Dallas, TX 75234
(214) 243-5050

Portland Wire & Iron Works
Portland, OR 97202
(503) 234-9731

RPS Architectural Systems*
North Hollywood, CA 91605
(213) 982-5866

ALUCOBOND is the trademark of Consolidated Aluminum Corporation for its aluminum composite material.

Technical information with reference to ALUCOBOND™ material test results can be obtained by writing to Consolidated Aluminum, Attention: Carla Lane. Always consult local building codes before use.

**System design and fabrication for the buildings on the preceding page were by RPS Architectural Systems.*

 **CONSOLIDATED ALUMINUM™**

11960 Westline Industrial Drive
St. Louis, Missouri 63141

ULTRAWALL[®] movable partitions predecorated vinyl elegance at the cost of painted drywall!

Compare! With ULTRAWALL movable partitions, carpeting, ceilings, lighting, core and perimeter walls are all finished first... **before** ULTRAWALL partitions are quickly installed. There are no cut-up areas to work around—or taping and sanding to scuttle your schedule. Doors, frames, base, finish, trim and glazing are all handled by one contractor. This means move-in dates can be moved up for earlier occupancy and significant savings on financing—plus possible qualification for investment tax credit and accelerated depreciation advantages.

ULTRAWALL panels are 3/4" thick for that solid, permanent wall feeling. Completed partitions offer you a 1-hour fire rating, 40 to 48 STC rating, rich contemporary wall fashions and easy vinyl washability. With all this, why put up with the dust, din and delays of costly fixed partitions—especially at relocation time. Call your U.S.G. representative. Or write to us at 101 S. Wacker Dr., Chicago, IL 60606, Dept. AJ880



UNITED STATES GYPSUM 
BUILDING AMERICA

Circle 27 on information card

SOME THINGS
WILL BE AROUND
A LONG TIME

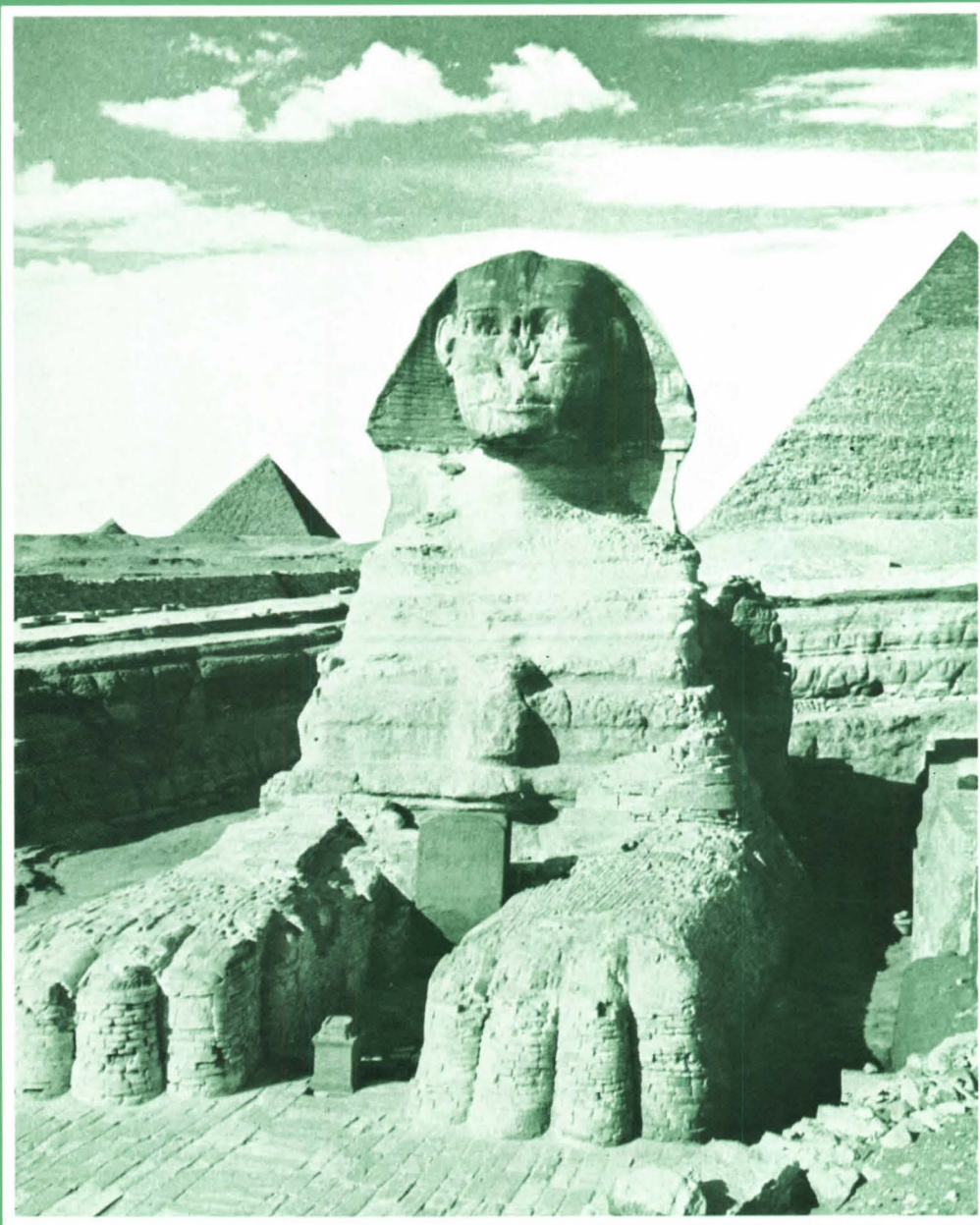

Like the sphinx and the pyramids, a structure of brick from BELDEN will withstand the years. Brick stands for character and for keeps. But unlike the architects of the Pharaohs, your choice of color, texture, and

THE Belden
Brick
COMPANY
CANTON, OHIO 44701

size is virtually unlimited. A selection of over 200 variations is yours from BELDEN. Your Belden Dealer will show you the facts, or write for a catalog to Box 910, Canton, Ohio 44701

Circle 28 on information card



Above: Bullock's Department Store in San José, Cal. Note Grinnell Quick Response Sprinklers installed in a sprinkler line suspended from a cable below the fabric roof. Photo courtesy of Virgil R. Carter, Architect, Environmental Planning & Research, Inc.

Right above: Grinnell's Model F931 Quick Response Sprinkler.

Circle 49 on information card

The sky's the limit. Grinnell® Sprinklers Can Meet the Challenge of Your Most Challenging Designs.

When Bullock's in San Jose, California's Oakridge Mall installed the first fabric roof ever used in a department store, they chose Grinnell sprinklers.

The problem that faced the owners, the architects and the insurance company was how to provide needed sprinkler protection that could respond quickly and effectively to a fire when the sprinkler lines were suspended from cables as much as 17' below the fabric roof.

The fiberglass fabric roof coated with TEFLON* made conventional pipe hangers impossible. The only practical manner to support the sprinkler system was from the suspension cables which were an integral part of the overall building design.

This innovative design called for an innovative technology, which was met by the use of Grinnell's Model F931 Quick Response attachment. This sprinkler combines the time-tested Duraspeed Sprinkler with an additional heat detection device sensitive to a temperature rate of rise at 20°F per second.

The Quick Response device attaches in a matter of seconds to a Duraspeed solder-type sprinkler. Thus, standard pendent sprinklers as well as horizontal sidewall models were available for use in this overall design.

This unique fast-acting sprinkler attachment, listed by Underwriters Laboratories, proved its capabilities in a test program witnessed by the owner's representatives and representatives of the insurance authorities.

Not only did the sprinkler attachment prove to be effective in the laboratory test, but it also demonstrated the flexibility needed to adapt to the demands of the structure's unconventional roof lines.

When it comes to sprinkler designs from the traditional to the avant-garde, Grinnell has the technology to provide sprinkler protection to match your most demanding design requirements.

For additional information, please write:
Grinnell Fire Protection Systems Co., Inc.
10 Dorrance St.
Providence, R.I. 02903

*TEFLON® is Du Pont's registered trademark for its fluorocarbon resin and film.

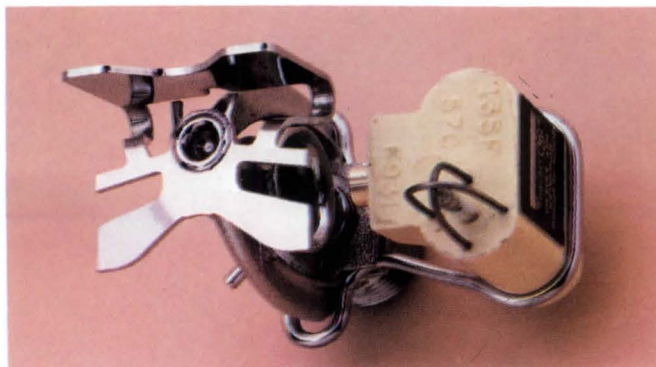

GRINNELL
GRINNELL FIRE PROTECTION SYSTEMS COMPANY, INC.
Protecting Life and Property Since 1850

WOULD YOU RISK TO SAVE A FEW

There are 143 different door manufacturers out there. All eager for your business.

Some promise you "the best door at the lowest price." Others say "quality at a competitive price." Then there's the claim, "we will not be undersold."

Who can an architect really believe?

Hint: Stick with the door people with a solid reputation.

Suggestion: Weyerhaeuser.

Quite frankly, we aren't the only people in the door business with a good background. But we are the only door supplier with seven essential points of difference.

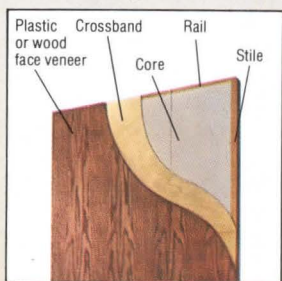

The quality goes all the way through.

They run like this:

1. Weyerhaeuser has the broadest line of flush wood doors in the world. Interior and exterior. Fire doors rated from 90 minutes to 20 minutes. Sound retardant. X-ray. You name it, we make it.

2. Weyerhaeuser fabricates all our own core components. Hollow. Staved. Timblend®. Mineral. We pay as much attention to the part you don't see as the part you do.

3. Weyerhaeuser extra touches set us apart as well. Hardwood side edges to match faces. Stiles and rails bonded to the core. Type I fully waterproof glue. Permanent identification with colored dowels for easy verification and reference.

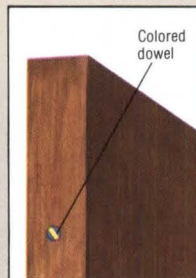

Our finishing touches make the difference.



YOUR REPUTATION DOLLARS A DOOR?

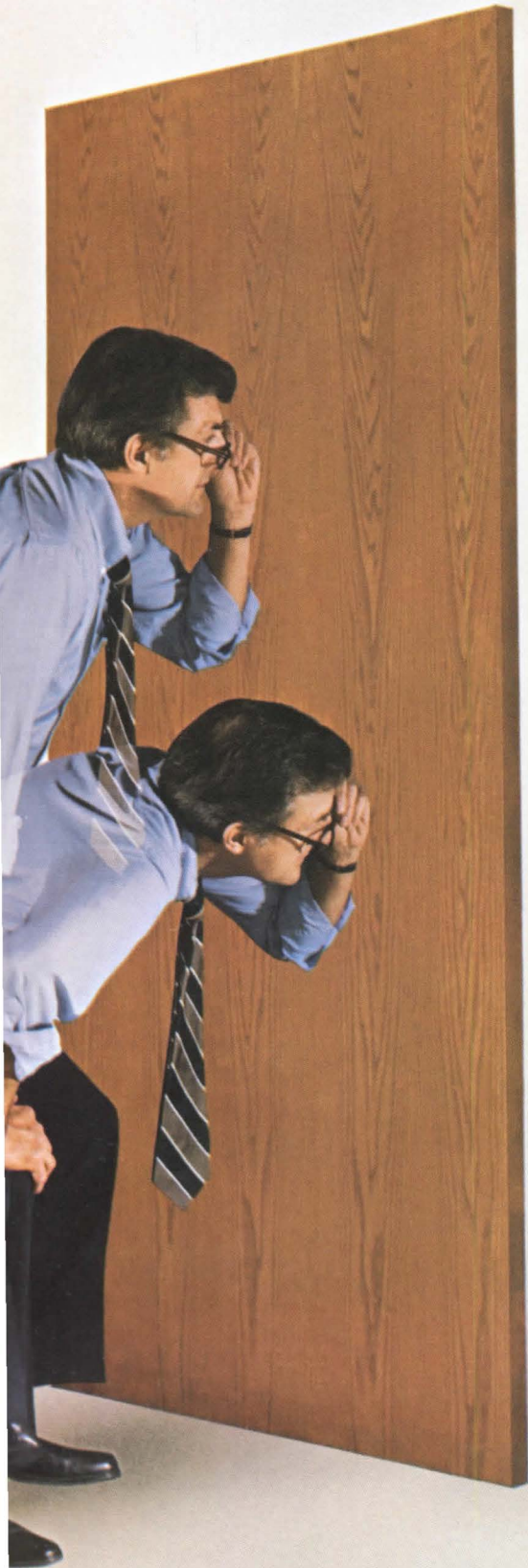

4. Our doors are readily available. Many Weyerhaeuser Customer Service Centers across the country carry a local inventory. Or you can order them from our plant in Marshfield, Wisconsin.

5. No one beats Weyerhaeuser on choices of faces. Hardwood veneers. Plastic laminate faces. MDO. More than 100 selections. They're all our specialty.



We have a face to match your plan.

6. The Weyerhaeuser warranty is the toughest in the business. And that's no advertising claim. It's fact. We back you up.

7. Finally, we offer a wide range of custom services. Factory finishing. Prefitting. Edge beveling. Cutting for hardware. Decay protection.

Now you might be able to specify a door that's cheaper than Weyerhaeuser. But in no way can that door live up to our 80 years of manufacturing experience, our 7 major points of difference and the Weyerhaeuser reputation.

So the next time *your* reputation goes on the line, think of Weyerhaeuser.

That way, both our good names will have a chance to shine.

For more information, write: Weyerhaeuser, Box B, Tacoma, WA 98401. Or just check Sweets.

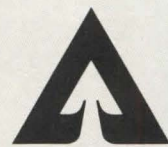

Weyerhaeuser

Circle 30 on information card

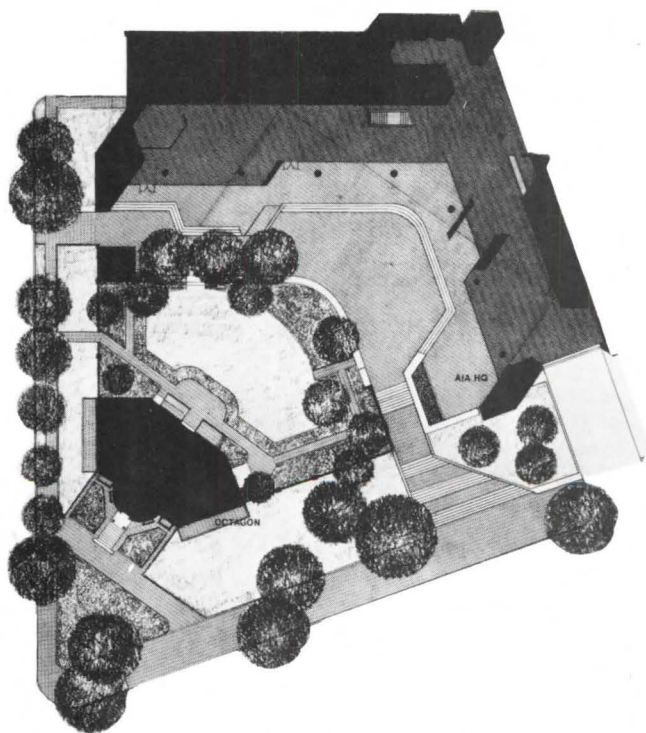

The AIA Building At Age 7

*Text and photographs
by Allen Freeman*



The AIA national headquarters staff first occupied its new office structure seven years ago. Its designer was The Architects Collaborative, chosen after Mitchell/Giurgola—which first won a competition for a smaller version of the building in 1964—reached an impasse with the Commission of Fine Arts over the new structure's relationship with the Octagon house.

The history of the building as constructed began with the selection of TAC in May 1969 by a committee of prominent architects. The Commission of Fine Arts approved TAC's design a year later, groundbreaking took place in March 1971 and the staff moved in two years after that. Construction cost was \$7.486 million;

approximately 195,000 square feet of floor space were provided.

The headquarters building wraps around the Octagon on its corner lot at 18th Street and New York Avenue, preserves the rear garden of the historic structure and contributes a brick courtyard that becomes the new building's entrance platform. The curving exterior of gray precast concrete and glass rises seven floors above the courtyard; below the ground level is an additional floor for staff use and one level of parking space.

The Institute staff and the staffs of three related organizations occupy the basement level and floors one, two and three. The related organizations, situated in the west wing of the first floor, are the Association of Collegiate Schools of Architecture, Production Systems for Architects and Engineers and the National Architectural Accrediting Board. The AIA Research Corporation has offices on half of the

fourth floor and the top three are for tenant offices, which include the National Council of Architectural Registration Boards. The AIA Foundation owns and occupies the Octagon, which contains period rooms and exhibit space.

The photographs on these and the following pages are intended to show some of the uses of the building today. In 1970, during the design stage, Norman Fletcher, FAIA, TAC's principal in charge for the headquarters, wrote of his concept: "... the building should have serenity and dignity and not seek a self-conscious monumentality. It should be inviting and not designed to overawe its visitors and the profession. In essence, the building should create an active 'environment' rather than an aggressive architectural form."

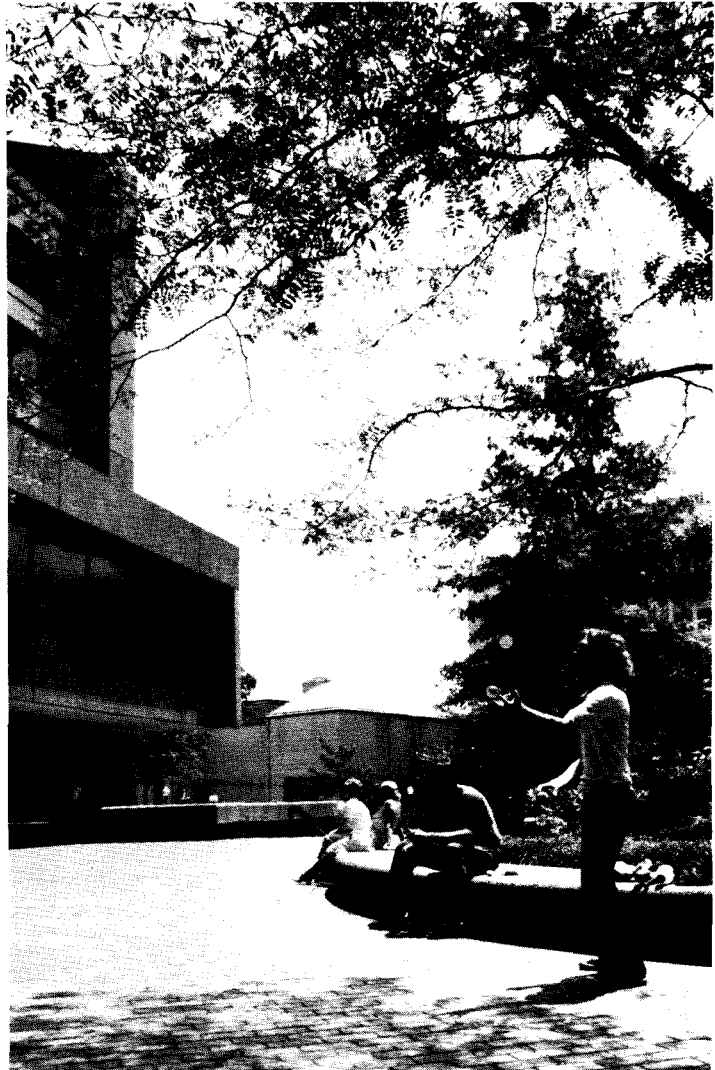
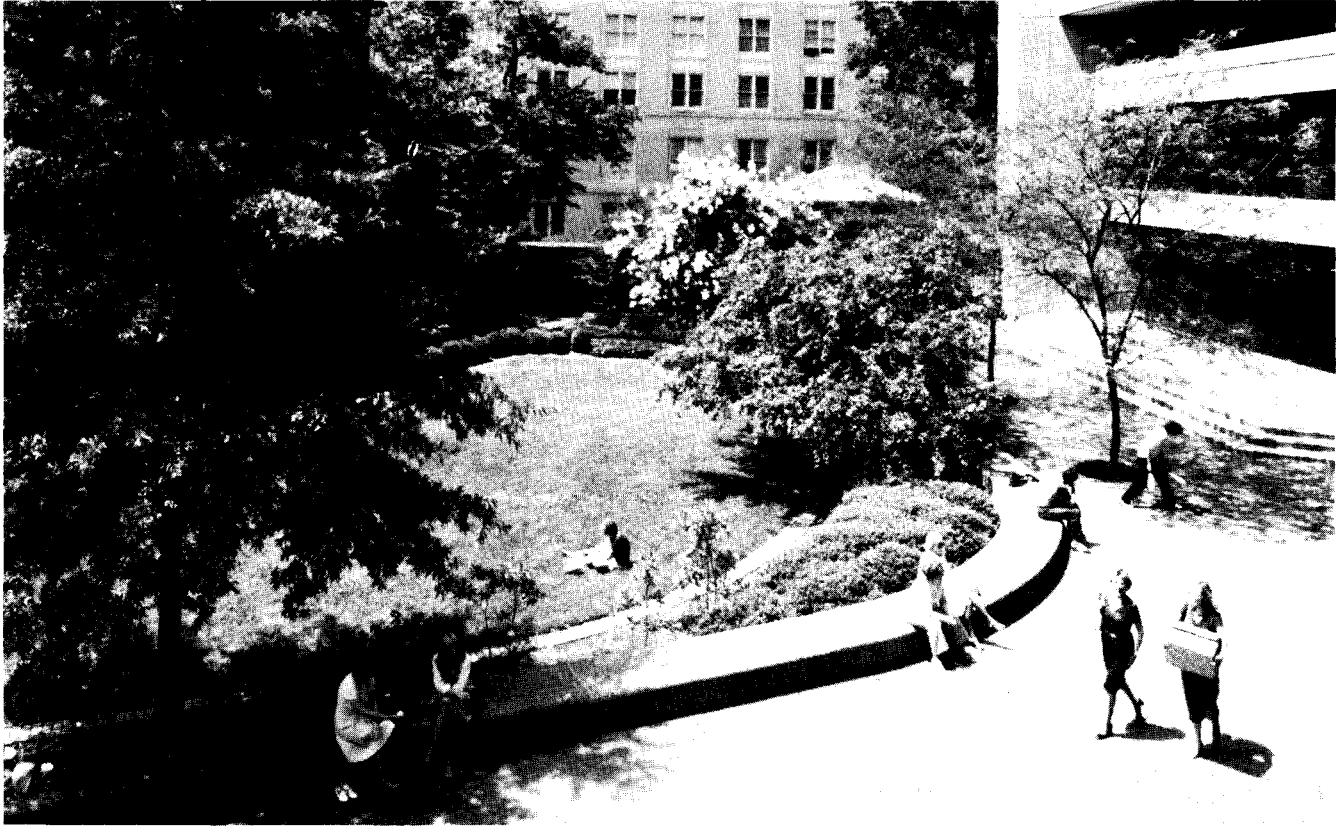

Courtyard and garden, isolated from traffic noise, form a pleasant area between the 180-year-old Octagon and its more recent companion building. The ledge at courtyard edge provides a place to sit and observe those entering or leaving the headquarters or those who choose to cut through rather than walking to the corner.

Cantilevered from the second floor of the newer building is the board room (photo at right), which shelters the main entrance (above). The courtyard's brick paving continues uninterrupted into the first floor's reception area, library and exhibit space.

When the class of **2130** departs we expect this Revere copper roof will still be on campus.

BROOKHAVEN COLLEGE, FARMERS BRANCH—Dallas County, Texas
Architect—PRATT, BOX, HENDERSON and PARTNERS, Dallas, Texas
Construction Manager—AVERY MAYS CONSTRUCTION COMPANY, Dallas, Texas
Sheet Metal Contractor—EVERSOLE COMPANY, Dallas, Texas
Revere Distributor—STANDARD METALS DIVISION of AZCON CORPORATION,
Houston, Texas

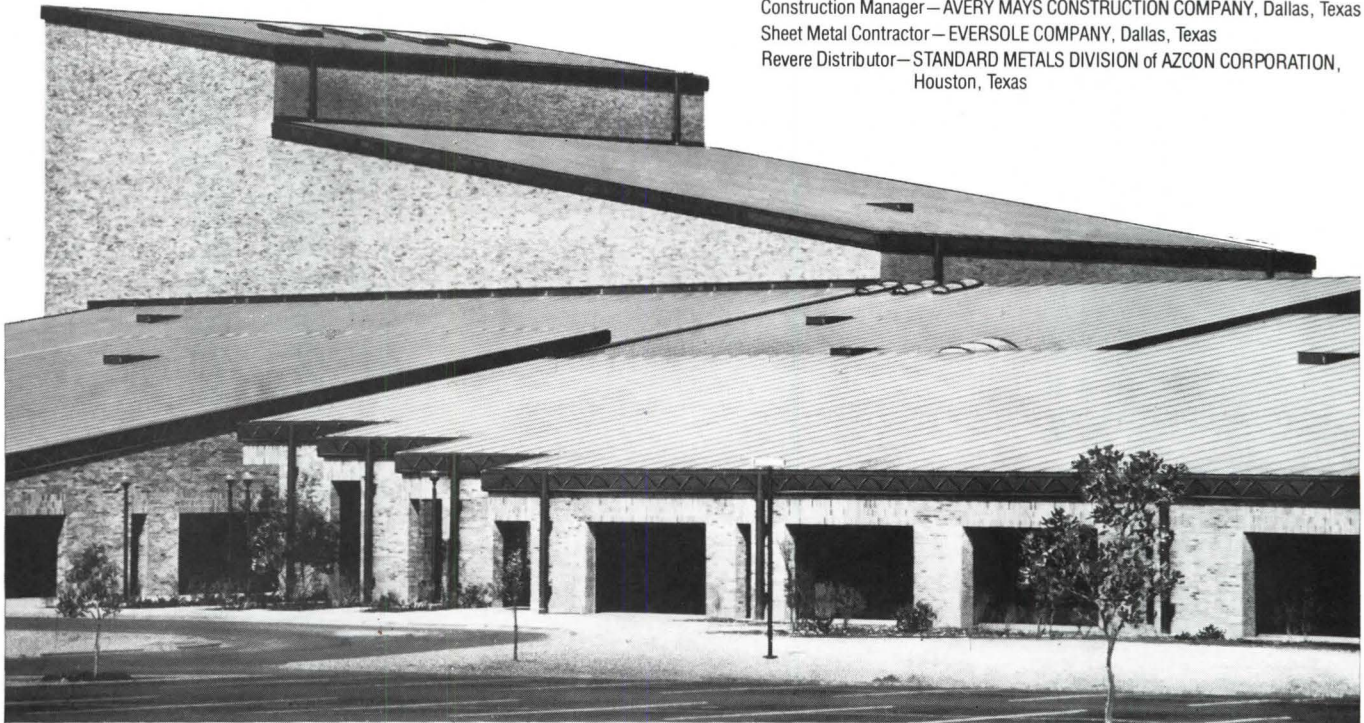

Copper roofs have been known to last for 150 or more years, so the college building shown above should still have its original copper roof in the 22nd century. This enduring quality is one of the reasons so many architects specify copper.

Another reason for "crowning with copper" is the natural warm tone of red metal which complements other building materials. Copper and brick, for example, are a natural, as they are in the building above.

Building owners appreciate the low cost per year of copper because it requires little, if any, maintenance. Another advantage of copper is its ease of installation. Copper can be formed

into any configuration you design and joints are easily soldered.

More than 400,000 pounds of 16 oz. and 20 oz. Revere sheet copper were used on eight buildings at the Brookhaven College. Construction is standing seam over gypsum deck. You can design with freedom and confidence with copper because it lends itself to so many types of construction: horizontal and vertical batten, flat seam and Bermuda style, to name a few.

Revere has a wealth of data on copper for roofing, flashing and other applications which we will gladly share with you. Just drop us a line. Revere Copper and Brass Incorporated, 605 Third Avenue, New York, NY 10016.



REVERE

Circle 31 on information card

Instant walls with the master's touch.

Like the celebrated Craft Guilds of yesteryear, today's league of Gold Bond Master Partition Specialists are skilled creators of inner space. They are craftsmen in the art of erecting the new, fully-accessible, demountable partition system from Gold Bond — GB-350.

This revolutionary gravity lock wall system, using a patented clip, unique horizontal steel rail and stud system, is unmatched for speed of erection . . .

and fast, easy demounting and rearrangement. The result is a high-performance wall at a highly competitive price.

To assure the highest standards of workmanship and quality, GB-350 is available through a limited number of select Master Partition Specialists around the country. More and more architects, building owners and managers have discovered the many unique advantages of Gold Bond GB-350, and its companion, Durasan pre-decorated gypsum wallboard.

For complete information on GB-350, contact the Authorized GB-350 Master Partition Specialist in your area by calling 1-800-821-7700, extension 350. (Missouri residents call 1-800-892-7655, extension 350). Additional details are also available in Sweet's General Building File 10Go; or, write Gold Bond Building Products A National Gypsum Division Dept. AIA/2001 Rexford Road Charlotte, North Carolina 28211.



Gold Bond
GB-350
GRAVITY LOCK
Demountable
Partition System



**Gold Bond
Building
Products**

A National Gypsum Division

Answers that make the difference.

Circle 32 on information card

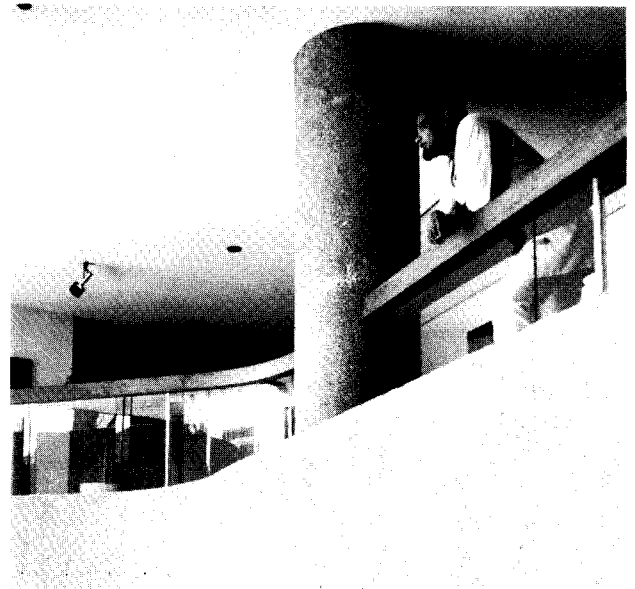

The second floor is where members participate in many of the ceremonial, social and meeting functions of the Institute. The board room (above), with two tiers of circular tables and a full-width window overlooking the courtyard, is the building's largest uninterrupted meeting space. The executive dining room (left) and two conference rooms (one in use, below left) accommodate smaller groups.

On the floor's wing opposite the board room (the building plan is a boomerang in shape) are executive offices and offices of some other staff. Between the two is the social gallery.

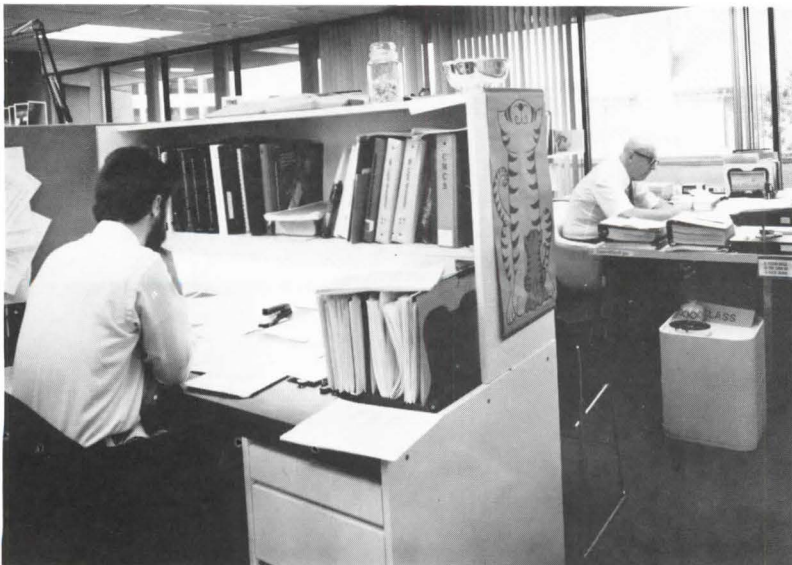

Most of the staff members work in the open landscaped third floor, where they share daylight and views to the Octagon. Workers in both wings of this floor are arrayed along double loaded corridors, their offices separated by green and orange fabric partitions and white laminated work units.

Beyond the display of publications in the photo at the top of this page are two recent additions to the floor: enclosed conference rooms which adjoin executive office spaces.

Data processing functions (above left) now take place in an enclosed space formerly occupied by two small conference rooms. □

Architect:
"To enhance
the traditional
and contemporary
elements of my
design, I specified
Shakertown Siding."

Frederic Albert,
Cassway/Albert &
Associates, Architects



Architect's residence,
Bryn Mawr, Pennsylvania
Carpenter holding
Shakertown 7" Colonial
Shingle Texture Siding

It's the easy way
to put up
cedar shingles.



Now there's an easy, more affordable way to add the beauty and texture of cedar shakes or shingles to your designs.

Shakertown Siding. It's made of straight grained # 1 grade western red cedar shingles or shakes, permanently bonded to an 8-foot-long plywood backing. There are no seconds or grade falldown.

Application is 3 times faster than

individual shingles or shakes. No specialized labor or tools are needed. And with most building codes, Shakertown Siding can be applied directly to framing, so no sheathing or stripping is required.

So construction is faster, labor costs lower. And the look you get is always straight and true, because Shakertown Siding is

automatically self-aligning.

On your next job, specify Shakertown Siding. It's available in 4 textures with 7" or 14" exposures and even or staggered butt lines.

Write us for complete product information and specification details.



Shakertown Siding

Box 400, Winlock, Washington 98596, Phone (206) 785-3501. In Canada: Bestwood Industries, Ltd., 6188 Kingsway, Burnaby, B.C. V5J 1H5
The Easy Way

Circle 33 on information card

The following is a key word index, a quick reference for finding the AIA or affiliated organization staff member who can answer your questions. Telephone numbers begin with 626 unless noted. The area code is 202. AIA's hotline is (202) 626-5954.

Subject	Staff	Telephone
Accident Insurance	William G. Wolverton, Hon. AIA	7322
Accounting Office	Ronald J. Panciera	7325
Accounting System, Computerized (PSAE)	John H. Schruben, FAIA	7369
Accreditation of Architectural Schools	Hugo Blasdel, NAAB James E. Ellison, AIA	783-2007 7347
Advertising (AIA Journal)	Michael M. Wood	7482
Advertising by National AIA	Muriel Campaglia	7459
Advocacy	William Street	7434
A/E Selection, National Government	Arnold J. Prima Jr., AIA	7374
A/E Selection, State	Elizabeth Chalmers	7385
Affirmative Action Minorities	William Street	7434
Women	Susan Allen	7376
Agreements (AIA Forms) Interpretations	Charles R. Heuer, AIA	7440
Orders/Sales	Terry L. Peck	7485
AIA Corporation, President	David O. Meeker Jr., FAIA	7310
AIA Filing System	Robert A. Class, AIA	7457
AIA Foundation President	Jeane Butler Hodges	638-3105
The Octagon		
AIA Minority/ Disadvantaged Scholarship Program	Raymond Charity Jr.	7349
AIA Production Systems for Architects & Engineers (PSAE) President	John H. Schruben, FAIA	7369
AIA Research Corporation President	Charles R. Ince Jr.	7500
AIA Scholarship Program	Raymond Charity Jr.	7349
AIA Standard Documents Interpretation	Charles R. Heuer, AIA	7440
Orders/Sales	Terry L. Peck	7485
Annual Committee Reports	James Schuping	7502
Arbitration	Charles R. Heuer, AIA	7454
Architect/Engineer Liaison	James A. Scheeler, FAIA	7315
Architect/Owner Relations	Charles R. Heuer, AIA	7454
Architect's Handbook of Professional Practice Orders/Sales	Charles R. Heuer, AIA Terry L. Peck	7454 7485
Architects in Government	Frank Musica	7382
Architects in Industry	Professional Interest Programs	7364
Architects Liability Committee	William Hooper, AIA	7449
Architectural Education Counseling	Raymond Charity Jr.	7349
Architectural Graphic Standards	Robert T. Packard, AIA	7454
Order/Sales	Kathie Davis	7474
Architectural Secretaries Association	Susan Allen	7376
Architectural Study Tours	Syed Ali	7467
Architectural Training	Suzon Loomis	7355
Archives, Institute	Tony P. Wrenn	7496
Arts and Recreation, Architecture for the	Professional Interest Programs	7364

Subject	Staff	Telephone
ASHRAE	David C. Bullen, AIA	7448
Associate Members	John Wilson-Jeronimo	7378
Associated General Contractors	Robert T. Packard, AIA	7454
Association of Architectural Librarians	Stephanie Byrnes	7494
Association of Collegiate Schools of Architecture (ACSA) Executive Director	Richard McCommons	785-2324
Association of Student Chapters	Student President	7472
Audio Tape Cassettes	Student Vice President	7472
Audiovisual Materials	Publications Fulfillment	7332
Awards Programs	Library	7295
Baldwin Memorial Archives	Maria Murray, Hon. AIA	7390
Barrier-Free Architecture	Library	7493
Benefit Insurance	James R. Dowling	7456
BEPS	Dale R. Ellickson, AIA	7469
Bibliographies, Requests for Library	William G. Wolverton, Hon. AIA	7322
Board of Directors	John R. Hoke Jr., AIA	7427
Bonds	Library	7493
Building Codes & Regulations	James Schuping	7502
Building Security	Charles R. Heuer, AIA	7440
Building Standards	James R. Dowling	7456
Building Types & Design Professional Interest Programs	Dale R. Ellickson, AIA	7469
Business Management Dept.	James R. Dowling	7456
Bylaws (Institute)	Dale R. Ellickson, AIA	7469
Bylaws (Component)	Professional Interest Programs	7364
CACE	William G. Wolverton, Hon. AIA	7332
Careers in Architecture	James Schuping	7502
Cases, Legal Citations	Harriet Halbig	7549
Catering Services (headquarters)	Betty Musselman	7489
Change of Address	John Wilson-Jeronimo	7378
Clearinghouse of State Legislation	Raymond Charity Jr.	7349
Code of Ethics and Professional Conduct	Charles R. Heuer, AIA	7440
Codes and Standards	Tom Ainsworth	7335
College of Fellows	Sherry Currens	7386
Commerce & Industry, Architects for Professional Interest Programs	James Schuping	7502
Committee on Federal Procurement of A/E Services (COFPAES)	James R. Dowling	7456
Committees, AIA	Dale R. Ellickson, AIA	7469
Community Design Center Program (CDC)	Syed Ali	7467
Community Services	Professional Interest Programs	7364
Compensation Management	Arnold J. Prima	7374
Competitions, Architectural	Evan Dudik	7375
Competitive Bidding	James Schuping	7502
Component Affairs Chapter	William Street	7434
State	William Street	7434
Component Clearinghouse	Robert A. Class, AIA	7457
Component President's Letter	William Lehr	7362
	Elizabeth Chalmers	7385
	John Wilson-Jeronimo	7378
	Susan Allen	7376
	Elizabeth Chalmers	7385
	Susan Allen	7376
	Catherine M. Krieger	7377

Subject	Staff	Telephone
Component Public Relations Assistance	Bette Callet	7464
Conference on Federal Agency Construction Programs	Frank Musica	7382
Congressional Liaison	Davis Tomasin	7379
	Meg McGrail	7381
Construction Contract Administration	Charles R. Heuer, AIA	7440
Construction Management/Design Build	William Hooper, AIA	7449
Construction Products Manufacturers Council Liaison	James A. Scheeler, FAIA	7315
Consumer Products Safety Commission	James R. Dowling	7456
	Dale R. Ellickson, AIA	7469
Continuing Education Program	Cameron Tucker	7354
Contractor-Architect Relations	Charles R. Heuer, AIA	7440
Contractors Liaison	Robert T. Packard, AIA	7454
Contracts and Forms Interpretations	Charles R. Heuer, AIA	7440
Orders/Sales	Terry L. Peck	7485
Controller	William G. Wolverton, Hon. AIA	7322
Convention, AIA	Frank X. Brown	7395
	Ketchie Brassel	7396
	Syed Ali	7467
	Charles R. Heuer, AIA	7440
Copyrights (AIA Documents)		
Corporations	Charles R. Heuer, AIA	7440
Cost-Based Compensation	Robert A. Class, AIA	7457
Council of Architectural Component Executives	John Wilson-Jeronimo	7378
Council of Black Architectural Schools	Raymond Charity Jr.	7349
Current Techniques in Architectural Practice	Robert A. Class, AIA	7457
Data Processing	Tom Ainsworth	7335
Design-Build/Construction Management	Dale R. Ellickson, AIA	7469
	William Hooper, AIA	7449
Design Competitions	William Lehr	7362
	Maria Murray, Hon. AIA	7390
Design Programs	John Gaillard	7363
Dimensional Coordination	Robert Packard, AIA	7454
Disability Insurance	William G. Wolverton, Hon. AIA	7332
Documents Committee	Charles R. Heuer, AIA	7440
Documents Subscription Service		
Interpretations	Charles R. Heuer, AIA	7440
Orders/Sales	Terry L. Peck	7485
Dues (AIA Membership)	Ronald J. Panciera	7325
Education, Architecture for Professional Interest Programs		7364
Education and Professional Development	James E. Ellison, AIA	7347
Education Fellowships and Grants	Raymond Charity Jr.	7349
Election Kits	Davis Tomasin	7379
Emblem of the Institute	Harriet Halbig	7549
Energy, Codes and Standards	James R. Dowling	7456
	Dale R. Ellickson, AIA	7469
Energy Committee	David C. Bullen, AIA	7448
Energy Information	Richard C. Depta, AIA	7452
Energy Network	Richard C. Depta, AIA	7452

Contacts for Help at AIA

Subject	Staff	Telephone	Subject	Staff	Telephone
Energy Publications	Kathie Davis	7474	Interior Design Documents	Charles R. Heuer, AIA	7440
Energy Research	Charles R. Ince, Jr.	7508	Intern-Architect	Robert Rosenfeld	7353
Engineer-Architect Interprofessional Relations	James A. Scheeler, FAIA	7315	Development Program (IDP)		
Environmental Design, Interprofessional Council	James A. Scheeler, FAIA	7315	Intern-Architect	Robert Rosenfeld	7353
Environmental Education	Alan R. Sandler	7573	Supplementary Education Program		
Environmental Policies	John Gaillard	7376	International Architects/ Agencies	Harriet Halbig	7549
Equal Employment Opportunity	Sheila Neary	7324	International Competitions	William Lehr	7362
Errors and Omissions Insurance	William Hooper, AIA	7449	International Practice	Robert A. Class, AIA	7457
Ethics	James Schuping	7502	International Relations	Harriet Halbig	7549
Executive Committee	James Schuping	7502	Internship Activities	Robert Rosenfeld	7353
Meetings	Harriet Halbig	7549	Interprofessional Council on Environmental Design	James A. Scheeler, FAIA	7315
Executive Vice President	David O. Meeker Jr., FAIA	7310	Joint Venture	William Street	7434
Executives, Component	John Wilson-Jeronimo	7378	Journal		
Federal Agencies Committee	Frank Musica	7382	Circulation	Brenda Owens	7327
Federal Agency Programs	Frank Musica	7382	Editor	Donald Canty	7477
Fellows Program	Maureen Marx, Hon. AIA	7392	Production Manager	George Dant	7484
Filing System, Product Literature	Becky Burt	7309	Publisher	Michael J. Hanley	7470
Film Sales/Loans	Library	7495	Sales Manager	Michael M. Wood	7482
Financial Management	Robert A. Class, AIA	7457	Justice, Architecture for Professional Interest Programs		7364
Firesafety in Buildings	James R. Dowling	7456	Labor Liaison	Arnold J. Prima, Jr., AIA	7374
	Dale R. Ellickson, AIA	7469		Frank Musica	7382
Five Presidents' Council	James E. Ellison, AIA	7347	Legal Citator	Charles A. Heuer, AIA	7470
General Conditions	Charles R. Heuer, AIA	7440	Legal Counsel	Alan B. Stover, AIA	7388
General Counsel	Alan B. Stover, AIA	7388	Legal Questions		
Government Affairs, National	Arnold J. Prima Jr., AIA	7374	Documents, Practice, Liability	Charles R. Heuer, AIA	7440
Government Affairs, State and Local	Elizabeth Chalmers	7385	Local and State Government	Elizabeth Chalmers	7385
Graphic Standards, Architectural	Sherry Currens	7386	Institute Legal Matters	Alan B. Stover, AIA	7388
Orders/Sales	Robert T. Packard, AIA	7454	Legislation, Evaluation and Assistance (Energy)	David C. Bullen, AIA	7448
Grassroots	Kathie Davis	7474	Legislation, National	Davis Tomasin	7379
Handbook of Professional Practice, Revisions, etc.	Susan Allen	7376		Meg McGrail	7381
Orders/Sales	Robert T. Packard, AIA	7454	Legislation, State	Elizabeth Chalmers	7385
Headquarters/AIA Building	Terry L. Peck	7485	Legislative Minuteman Program	Davis Tomasin	7379
Health, Architecture for	Professional Interest Programs	7364	Liability Insurance	William Hooper, AIA	7449
Historic Preservation Programs	Professional Interest Programs	7364	Library		7493
Honor Awards and Special Awards Program	Maria Murray, Hon. AIA	7390	Liens	Charles R. Heuer, AIA	7440
Honorary Fellows	Harriet Halbig	7549	Life Cycle Cost Analysis	Robert A. Class, AIA	7457
Honorary Members	Maria Murray, Hon. AIA	7390	Life Insurance	William G. Wolverton, Hon. AIA	7322
Hospitalization Insurance	William G. Wolverton, Hon. AIA	7322	Local Government Affairs	Elizabeth Chalmers	7385
HOTLINE	Priscilla Bisch/ Harriet Halbig	5954 5954	Long Span Construction Panel	Brian Cook	7476
Housing Programs	Professional Interest Programs	7364	Mailing Lists	Kathie Davis	7474
In-Hospital Insurance	William G. Wolverton, Hon. AIA	7322	Mailroom	Andrew Baine	7339
Industry, Architects in	Professional Interest Programs	7364	Media Relations		
Insurance			National	Ray Rhinehart	7463
Benefit	William G. Wolverton, Hon. AIA	7322	Local	Bette Callet	7464
Liability	William Hooper, AIA	7449	Meetings (at headquarters)	Shelly Getchell	7397
Interior Architecture	Professional Interest Programs	7364	Membership Application	Maureen Marx, Hon. AIA	7392
			Membership Directory	Terry L. Peck	7485
			Orders		
			Membership Recruiting	Susan Allen	7376
			Membership Retention	James Schuping	7502
			Memo	Peter McCall	7465
			Metric Conversion	James R. Dowling	7456
				Dale R. Ellickson, AIA	7469
			Metric Council	James R. Dowling	7456
				Dale R. Ellickson, AIA	7469
			Mini-Grassroots	John Wilson-Jeronimo	7378

Subject	Staff	Telephone	Subject	Staff	Telephone
Minimum Property Standards	James R. Dowling	7456	Purchasing Department	Marjorie Ballengee	7324
Minority Data Bank	Dale R. Ellickson, AIA	7469	Recertification	James E. Ellison, AIA	7374
Minority/Disadvantaged Scholarships	William Street	7434	Regional Development	John Gaillard	7363
Minority Survey	Raymond Charity Jr.	7349	Regional/Urban Design Assistance Teams (R/UDAT)	John Gaillard	7363
Minuteman Program	William Street	7434	Registration		
Model Building Codes	Davis Tomasin	7379	NCARB		659-3996
National AIA Committees	James R. Dowling	7456	State Laws	Elizabeth Chalmers	7385
National Architectural Accrediting Board	James Schuping	7502	Registration Law	Elizabeth Chalmers	7385
National Component Seminars	Hugo Blasdel	783-2007	Advisory Task Force		
National Conference of States on Building Codes and Standards	James E. Ellison, AIA	7347	Research Corporation		7500
National Council of Architectural Registration Boards	Cameron Tucker	7354	President	Charles R. Ince Jr.	7508
National Forum on Growth Policy			Research Fellowships	Raymond Charity Jr.	7349
National Institute of Building Sciences	James R. Dowling	7456	Resolutions, Convention	Harriet Halbig	7549
National Legislation	Dale R. Ellickson, AIA	7469	Retirement Plan	William G. Wolverton, Hon. AIA	7322
National Organization for Minority Architects		783-6500	Rules of the Board	James Schuping	7502
New Releases	Michael B. Barker, AICP	7359	Scholarship Programs	Raymond Charity Jr.	7349
Nominations for National Institute Office			Schools of Architecture	Richard McCommons	785-2324
Occupational Safety and Health Act (OSHA)	James R. Dowling	7456	Seal of the Institute	Harriet Halbig	7549
Octagon House	Dale R. Ellickson, AIA	7469	Secretary, Assistant	James Schuping	7502
Partnerships	Davis Tomasin	7379	Seismic Codes and Standards	James R. Dowling	7456
Pension Programs	Meg McGrail	7381	Social Events	Dale R. Ellickson, AIA	7469
Personnel Office	William Street	7434	Solar Energy	Shelly Getchell	7397
Policy Statements			Speakers Bureau	John R. Hoke Jr., AIA	7427
Practice and Design Dept.	Public Relations Dept.	7460	Specialty Contractors	Susan Allen	7376
Practice Division	Harriet Halbig	7589	Standard Documents	Robert T. Packard, AIA	7454
Practice Management			Interpretations	Charles R. Heuer, AIA	7440
Preservation Programs	James R. Dowling	7456	Orders/Sales	Terry L. Peck	7485
Press Relations	Dale R. Ellickson, AIA	7469	Standard Forms 254-255	Frank Musica	7382
National	Jeanne Butler Hodges	638-3105	State and Local	Sherry Currens	7386
Local	Charles R. Heuer, AIA	7440	Government Documents		
Procurement—Federal Agency Procedures	William G. Wolverton, Hon. AIA	7332	State Government Affairs	Elizabeth Chalmers	7385
Production Systems for Architects and Engineers, Inc. (PSAE)	Sheila Neary	7324	State Government Affairs Committee	Elizabeth Chalmers	7385
Professional Development	James Schuping	7502	State Legislative Information	Elizabeth Chalmers	7385
Professional Interest Committees	Michael B. Barker, AICP	7359	State Registration Laws	Elizabeth Chalmers	7385
Corresponding Membership	Robert A. Class, AIA	7457	Student Affairs	Alex Barberena	7472
Professional Liability Insurance	Robert A. Class, AIA	7457	Student Competitions	Alex Barberena	7472
Program and Management Services	Professional Interest Programs	7364	Subcontractor Liaison	Robert T. Packard, AIA	7454
Programming, Architectural	Ray Rhinehart	7463	Sureties	Charles R. Heuer, AIA	7440
Public Policy	Bette Callet	7464	Switchboard	Hilda Gasch	7300
Public Relations Dept.	Frank Musica	7382	Technical Training Schools Program	Raymond Charity Jr.	7349
Publications Distribution	John H. Schruben, FAIA	7369	Training Laboratories, Architectural	Suzon Loomis	7355
Publications Marketing			Treasurer, Assistant	William A. Wolverton, Hon. AIA	7322
Publications Marketing/Sales	James E. Ellison, AIA	7347	Uniform Construction Index	Robert T. Packard, AIA	7454
	Maurice Payne, AIA	7364	Unprofessional Conduct Charges	Betty Musselman	7392
	William Hooper, AIA	7449	Urban Design	John Gaillard	7363
			Urban Planning		
	James A. Scheeler, FAIA	7315	Programs	John Gaillard	7363
	Robert A. Class, AIA	7457	Regional/Urban Design Assistance Teams	John Gaillard	7363
			Value Analysis	Michael B. Baker, AICP	7359
	Stanley Kolbe	7556	VISTA/AIA Joint Program	Frank Musica	7382
	Muriel Campaglia	7459	Professional Interest Programs		7364
	Terry L. Peck	7485	Women in Architecture	Susan Allen	7376
	David Godfrey	7450	Women's Architectural League	Susan Allen	7376
	Kathie Davis	7474			

Artistic Tiles Manufacturer, Inc.

AND THEIR DISTRIBUTORS

PROUDLY INTRODUCE



LE FIANDRE

P O R C E L A I N
S T O N E W A R E

TOTALLY VITRIFIED PAVERS

THE IDEAL SOLUTION TO ELIMINATE FLOORING PROBLEMS
IN SHOPPING MALLS, HOTELS, HOSPITALS, ETC. — KEEPING A WARMTH OF COLORS

For further information please contact:

CALIFORNIA

CERTICO
Ceramic Tile Co.
200 No. Tustin Ave.
Santa Ana, California 92705
714/541-2132

GEORGIA

GEORGIA TILE DISTRIBUTORS
4520 Palazzo Way
Douglasville, Georgia 30133
404/912-5422

ILLINOIS

CREATIVE SURFACES BY NEUBACHER
1400 Glenlake Ave.
Merchandise Mart
Itasca, (Chicago area) Illinois 60143
312/773-2950

KANSAS

CERAMIC TILE SALES
1970 Southwest Street
May Center Park #330
Wichita, Kansas 67217
316/945-8206

MISSOURI

MID-WEST TILE DISTRIBUTORS
5313 East 103rd
Kansas City, Missouri 64137
816/763-6363

YOUNG'S DISTRIBUTING CO., INC.
3149 S. Scenic
Springfield, Missouri 65807
417/881-6892

NEBRASKA

LUMBERMAN'S
6703 "L" Street
Omaha, Nebraska 68117
402/339-1121

OHIO

CERAMIC TILE DISTRIBUTORS, INC.
6898 Engle Road
Middleburg Heights, (Cleveland area) Ohio 44130
216/243-8950

MEES DISTRIBUTORS, INC.
1541 West Fork Rd.
Cincinnati, Ohio 45223
513/541-2311

OKLAHOMA

PLUNKETT CO. OF OKLAHOMA, INC.
900 Metropolitan Ave.
Oklahoma City, Oklahoma 73108
405/947-5681

PLUNKETT CO. OF OKLAHOMA, INC.
5818 So. 129th East Ave.
Tulsa, Oklahoma 74134
918/252-3686

TENNESSEE

W.A. OYLER DISTRIBUTING CO.
2636 Summer Ave.
Memphis, Tennessee 38112
401/324-6143

TEXAS

ARTISTIC TILES MANUFACTURER, INC.
1980 Afton Rd.
Houston, Texas 77055
713/681-4096

ARTISTIC TILES MANUFACTURER, INC.
11319 Indian Trail
Dallas, Texas 75229
214/247-5333

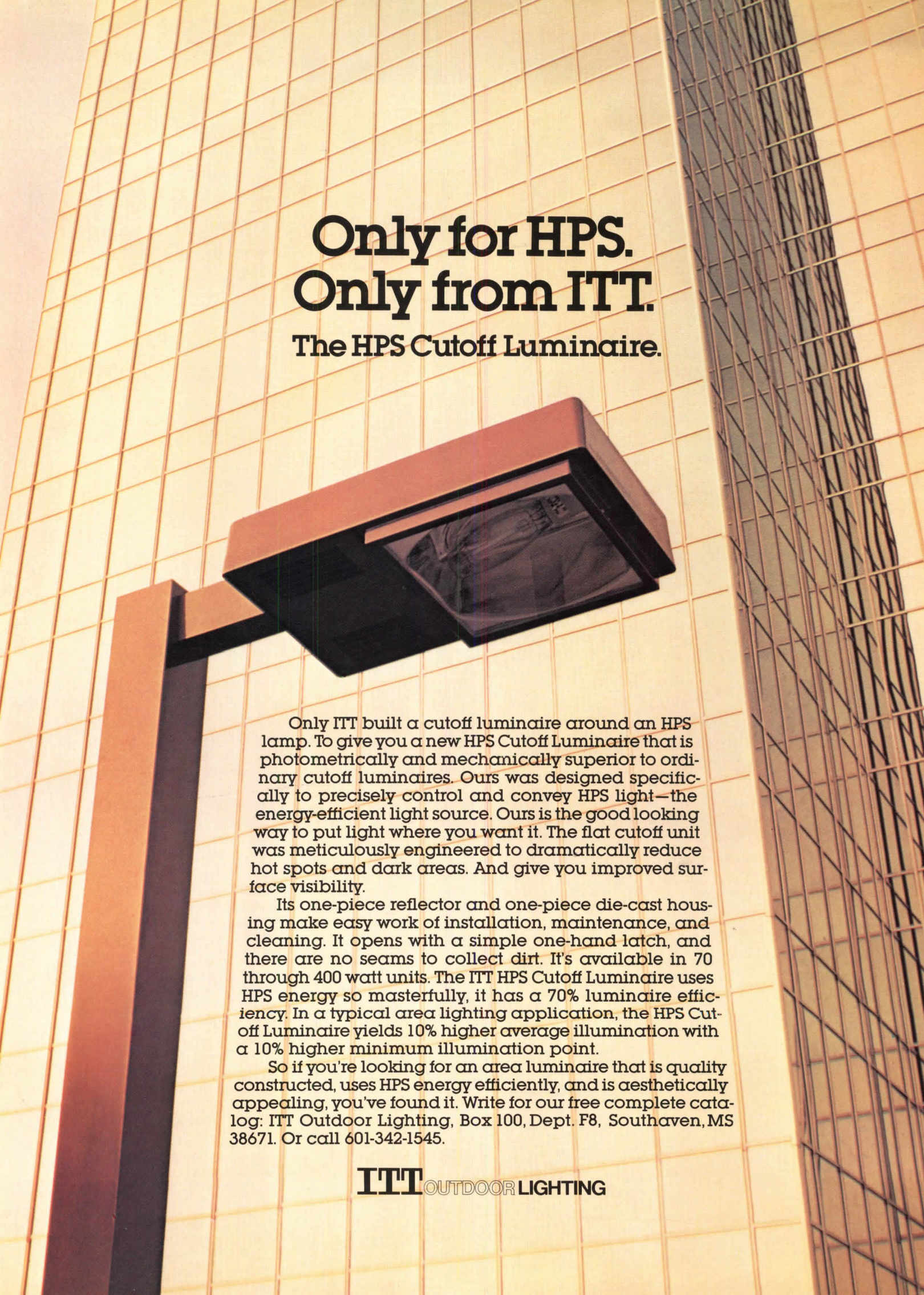

**Only for HPS.
Only from ITT.
The HPS Cutoff Luminaire.**

Only ITT built a cutoff luminaire around an HPS lamp. To give you a new HPS Cutoff Luminaire that is photometrically and mechanically superior to ordinary cutoff luminaires. Ours was designed specifically to precisely control and convey HPS light—the energy-efficient light source. Ours is the good looking way to put light where you want it. The flat cutoff unit was meticulously engineered to dramatically reduce hot spots and dark areas. And give you improved surface visibility.

Its one-piece reflector and one-piece die-cast housing make easy work of installation, maintenance, and cleaning. It opens with a simple one-hand latch, and there are no seams to collect dirt. It's available in 70 through 400 watt units. The ITT HPS Cutoff Luminaire uses HPS energy so masterfully, it has a 70% luminaire efficiency. In a typical area lighting application, the HPS Cutoff Luminaire yields 10% higher average illumination with a 10% higher minimum illumination point.

So if you're looking for an area luminaire that is quality constructed, uses HPS energy efficiently, and is aesthetically appealing, you've found it. Write for our free complete catalog: ITT Outdoor Lighting, Box 100, Dept. F8, Southaven, MS 38671. Or call 601-342-1545.

ITT OUTDOOR LIGHTING

A

AACJC
American Association of Community and Junior Colleges

AAES
American Association of Engineering Societies

AAHP
American Association for Hospital Planners

AAL
Association of Architectural Librarians

AASA
American Association of School Administrators

ABA
American Bar Association

ACA
American Correctional Association

ACEC
American Consulting Engineers Council

ACHP
Advisory Council on Historic Preservation

ACSA
Association of Collegiate Schools of Architecture

AEE
Association of Energy Engineers

AEI
Alternative Energy Institute

AERO
Alternative Energy Resource Organization

AGC
Associated General Contractors of America

AGS
Architectural Graphics Standards

AHA
American Hospital Association

AHCA
American Health Care Association

AIA
American Institute of Architects

AIA/RC
American Institute of Architects Research Corporation

AIC
American Institute of Constructors

AICP
American Institute of Certified Planners

ALDA
American Land Development Association

ANMC
American National Metric Council

ANSI
American National Standards Institute

APA
American Planning Association

APHA
American Public Health Association

APT
Association of Preservation Technology

ARTBA
American Road and Transportation Builders Association

ASA
Acoustical Society of America

ASA
Architectural Secretaries Association

ASC/AIA
Association of Student Chapters/AIA

ASCE
American Society of Civil Engineers

ASCP
American Society of Consulting Planners

ASE
Alliance to Save Energy

ASEA
American Society of Engineers and Architects

ASHRAE
American Society of Heating, Refrigeration and Air-Conditioning Engineers

ASID
American Society of Interior Designers

ASLA
American Society of Landscape Architects

ASME
American Society of Mechanical Engineers

AUA
Association of University Architects

AUA
American Underground Space Association

B

BCMC
Board of Coordination of Model Codes

BCTC
Building and Construction Trades Council, AFL-CIO

BEPS
Building Energy Performance Standards

BLM
Bureau of Land Management, Department of Interior

BOCA
Building Officials and Code Administrators International

BOMA
Building Owners and Managers Association International

BOMI
Building Owners and Managers Institute

BOR
Bureau of Outdoor Recreation, Department of Interior

BRAB
Building Research Advisory Board, National Academy of Sciences

C

CAA
Commonwealth Association of Architects

CABO
Council of American Building Officials

CAC
Construction Action Council

CACE
Council of Architectural Component Executives

CBT/NBS
Center for Building Technology, National Bureau of Standards

CDC
Community Design Center

CEC
Consulting Engineers Council

CEFP
Council of Educational Facility Planners

CEQ
Council on Environmental Quality

CEU
Continuing Education Unit

CFR/NBS
Center for Fire Research, National Bureau of Standards

CIAM
Congres Internationaux d' Architecture

CIMA
Construction Industry Manufacturers Association

CPAR
Committee for the Preservation of Architectural Records

CPMC
Construction Products Manufacturers Council

CPSC
Consumer Products Safety Commission

CRC
Construction Research Council

CSI
Construction Specifications Institute

Glossary of Acronyms and Abbreviations

D

- DOC
Department of Commerce
- DOD
Department of Defense
- DOE
Department of Energy
- DOT
Department of Transportation

E

- EBI
Energy Bureau, Inc.
- ED
Department of Education
- EDRA
Environmental Design Research
Association
- EEOC
Equal Employment Opportunity
Commission
- EERI
Earthquake Engineering Research
Institute
- EFL
Educational Facilities
Laboratories Inc.
- EGCA
Engineering and General
Contractors Association
- EPA
Environmental Protection Agency
- ERDAC
Energy Research and Development
Advisory Council

F

- FAA
Federal Aviation Administration,
Department of Transportation
- FAIA
Fellow of The American Institute
of Architects
- FCARM
Federacion de Colegios de Arquitectos
de la Republica Mexicana
- FCC/BRAB
Federal Construction Council,
Building Research Advisory Board
- FHA
Federal Housing Administration,
Department of Housing and
Urban Development
- FHwA
Federal Highway Administration,
Department of Transportation

- FIA
Federal Insurance Administration,
Department of Housing and
Urban Development
- FmHA
Farmers Home Administration,
Department of Agriculture
- FPAA
Federacion Panamericana de
Asociaciones de Arquitectos, Pan
American Federation of
Architects Associations
- FRA
Federal Railroad Administration,
Department of Transportation

G

- GSA
General Services Administration

H

- HABS
Historic American Buildings Survey
- HHS
Department of Health and
Human Services
- Hon. AIA
Honorary Member of The American
Institute of Architects
- Hon. FAIA
Honorary Fellow of The American
Institute of Architects
- HUD
Department of Housing and
Urban Development

I

- IAH
International Association for Housing
- IALD
International Association of
Lighting Designers
- ICAM
International Confederation of
Architectural Museums
- ICBO
International Conference of
Building Officials
- ICED
Interprofessional Council on
Environmental Design
- IDSA
Industrial Designers Society of
America
- IES
Illuminating Engineering Society
- IFRAA
Interfaith Forum on Religion,
Art and Architecture

continued on page 69

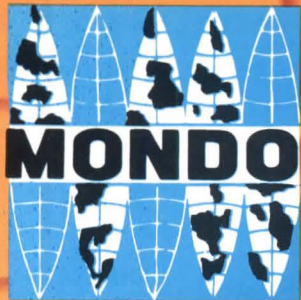

**RUBBER
CANADA** Ltd.

Rubber floor covering

Residential — Commercial — Sport — Naval

2655, rue Francis Hughes, Parc Industriel Chomedey
Laval, Québec H7L 3S8
Téléphone (514) 663-6260 Téléc 055-60046

Circle 36 on information card

Acronyms from page 67

- IIID**
International Institute of Interior Design
- IUD**
Institute for Urban Design

M

- MCSC**
Model Codes Standardizations Council

N

- NAAB**
National Architectural Accrediting Board
- NACO**
National Association of Counties
- NAD**
National Academy of Design
- NAHB**
National Association of Home Builders
- NAHB/RF**
National Association of Home Builders, Research Foundation
- NAHRO**
National Association of Housing and Redevelopment Officials
- NAR**
National Association of Realtors
- NAVFAC**
Naval Facilities Engineering Command, Department of Defense
- NAWC**
National Association of Women in Construction
- NBS**
National Bureau of Standards
- NCA**
National Constructors Association
- NCARB**
National Council of Architectural Registration Boards
- NCBFE**
National Center for a Barrier-Free Environment
- NCIC**
National Construction Industry Council
- NCSBCS**
National Conference of States on Building Codes and Standards
- NEA**
National Education Association
- NEAC**
National Energy Advisory Council
- NFPA**
National Fire Protection Association
- NFPCA**
National Fire Prevention and Control Administration

continued on page 71

ARCHITECT: PROBLEM: SOLUTION:

Jova/Daniels/Busby

Design a church interior that conveys a powerful sense of warmth and peace yet is as economical to maintain as it is inspirational for worship.

Brick

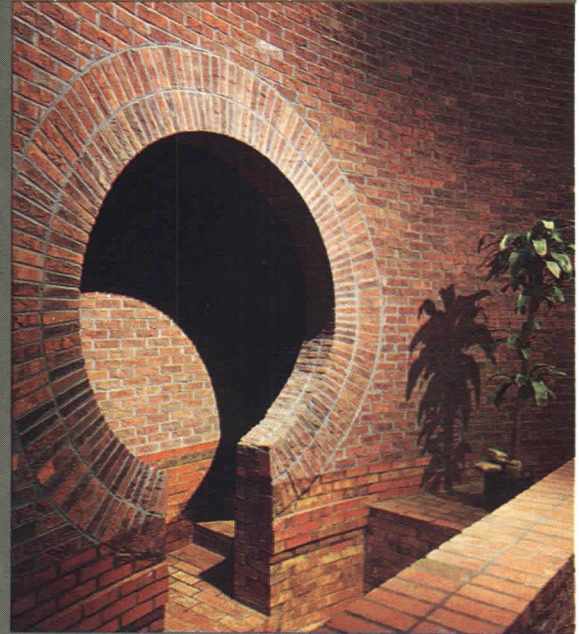

For more information about the design of the First Christian Church of Atlanta, request a free copy of Brick In Architecture, Volume 34, Number 2 from Brick Institute of America, 1750 Old Meadow Road, McLean, Virginia 22101.



BRICK INSTITUTE OF AMERICA

Circle 37 on information card

197 W/103

outstanding.

R-WAY
SEATING

Many styles of seating and occasional pieces

R-WAY FURNITURE CO., SHEBOYGAN, WI 53081 (414) 457-4833
showrooms: Chicago, New York, Minneapolis, Dallas, Atlanta, Seattle.

Circle 38 on information card

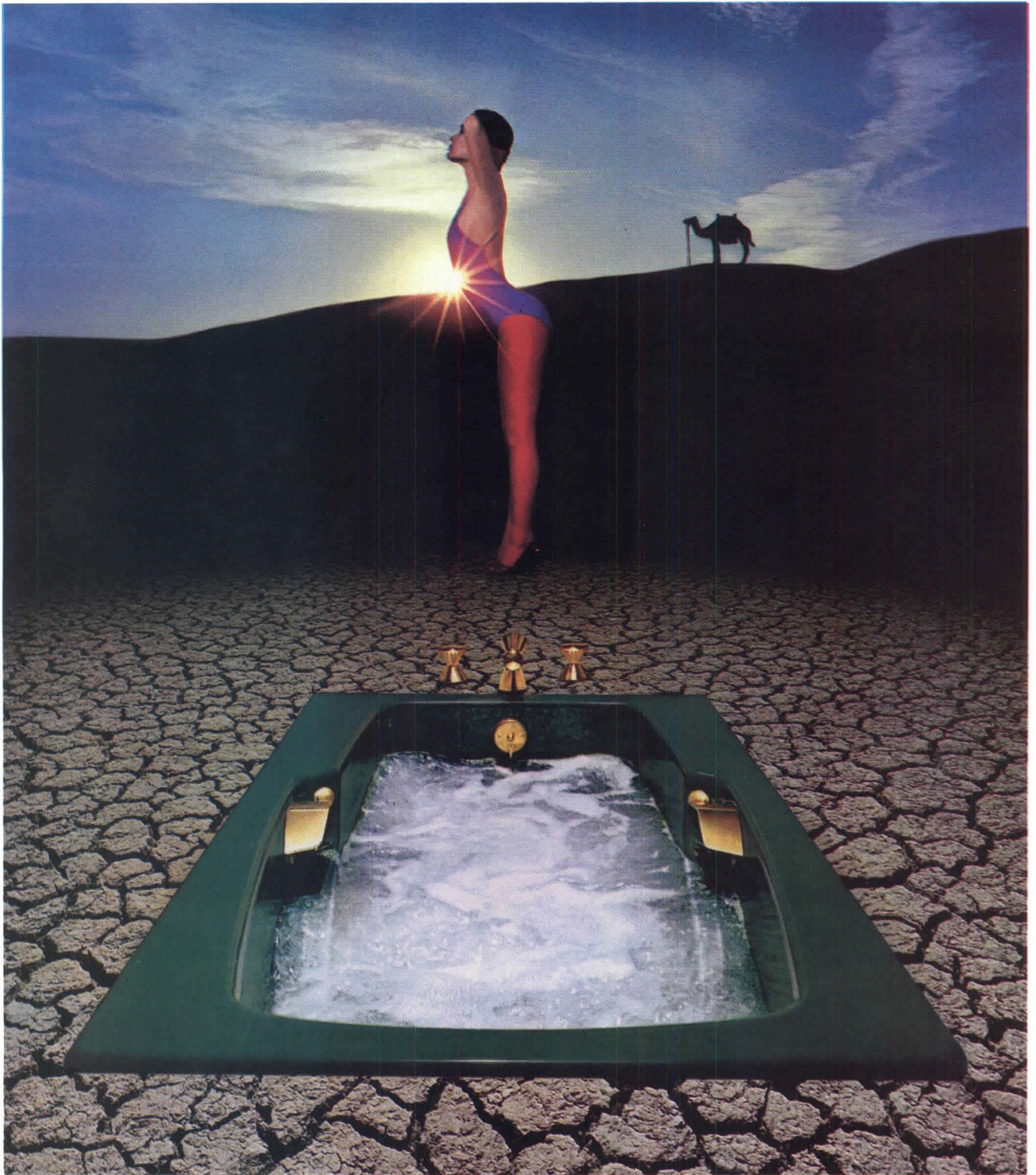

THE BOLD LOOK
OF **KOHLER**

At the edge of your imagination, fatigue dissolves in an oasis of sweet pleasure. The Steeping Bath Whirlpool. 5 feet long, 20 inches deep, and contoured for comfort. Available in a variety of unforgettable colors. Shown here in Evergreen, with Bravura faucet. For more information about Kohler products, write: Kohler Company, Dept. Z8, Kohler, Wisconsin 53044.

Acronyms from page 69

- NHRA**
National Housing Rehabilitation Association
- NIAE**
National Institute of Architectural Education
- NIBS**
National Institute of Building Sciences
- NOMA**
National Organization of Minority Architects
- NPS**
National Park Service, Interior Department
- NRBA**
National Recreation and Park Association
- NSBA**
National School Board Association
- NSC**
National Safety Council
- NSPE**
National Society of Professional Engineers
- NTHP**
National Trust for Historic Preservation
- NTIS**
National Technical Information Service

O

- OMBE**
Office of Minority Business Enterprise
- OPLR**
Office for Professional Liability Research, Victor O. Schinnerer & Co.

P

- PBS**
Public Buildings Service, General Services Administration
- PSAE**
Production Systems for Architects and Engineers
- PSMA**
Professional Services Management Association
- PSPA**
Passive Solar Products Association

R

- RAIA**
Royal Australian Institute of Architects
- RAIC**
Royal Architectural Institute of Canada

continued on page 73

ARCHITECT: PROBLEM: SOLUTION:

Caudill Rowlett Scott

Design a university arts center that makes a boldly contemporary architectural statement yet blends gracefully with the traditional buildings that make up the remainder of the campus.

Brick

For more information about the design of Wake Forest University's Fine Arts Center, request a free copy of *Brick in Architecture*, Volume 36, Number 1 from Brick Institute of America, 1750 Old Meadow Road, McLean, Virginia 22101.

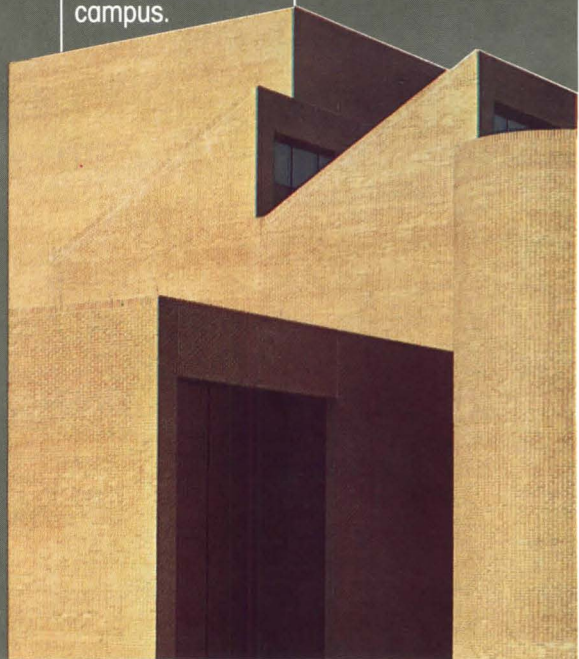

Circle 40 on information card



**Noise...
Control it.**

Eckoustic Functional Panels efficiently & effectively reduce background noise & reverberation.

Ideal for auditoriums, gyms, swimming pools, churches, etc. Easy installation. No need to relocate existing utilities. Attractive. Durable. Fireproof. Low maintenance. Graffiti resistant.



ECKEL INDUSTRIES, INC. Eckoustic Div.
155 Fawcett St., Cambridge, Mass. 02138 • 617-491-3221

Circle 41 on information card

HOW A FRIGID NEW ENGLAND ENVIRONMENT DEMONSTRATED THE EFFECTIVENESS OF PASSIVE SOLAR ENERGY AND EXOLITE™ SHEET.

EXOLITE double skinned sheet, the power of the sun, and a lot of design expertise allowed two facilities in New England to save energy and clobber winter.

Massive Trombe wall saves energy in Vermont warehouse.

A massive Trombe wall did the job for Famolare, Inc. at their warehouse addition in Brattleboro, Vermont.

The Trombe wall is 184 feet long and oriented 10° west of due south. Windowless except for 16 roof monitors, the wall is expected to contribute 38% of the building's heat, with the balance being provided by ceiling-hung oil-fired unit heaters.



Two basic components of the solar system are a 12-inch concrete block wall and EXOLITE double skinned acrylic sheet as the glazing material. The EXOLITE sheet is several inches from the concrete wall, providing a chamber into which cooler air enters through openings in the bottom of the wall. Air is returned to the room through openings at the top after being heated, as it flows over the surface of the warm wall.

During summer, the top opening to the room is closed, with hot air vented to the outside, providing natural ventilation.

A natural energy system becomes a learning experience for dormitory students.

Passive solar energy, simple in design and operation yet effective in saving fossil fuel, was adapted for dormitory and faculty housing at the White Mountain School in Littleton, New Hampshire. The long two-story building uses EXOLITE double skinned acrylic sheet in a series of

trates the room as well as the solarium, providing direct, passive solar heat to the rooms.

Not only has maintenance been minimal for the heating system, but the opportunity to create an energy awareness in its students has proved to be a giant plus for the school.

EXOLITE sheet: for all the energy under the sun.

EXOLITE double skinned sheet is an exciting, new-generation plastic sheet ideal for skylights, covered walkways, greenhouses and just about any application where daylight is required.

It has outstanding thermal insulation values and is an excellent passive solar energy material, opening exciting new design and construction possibilities for you.

If you want to know more, please contact us at West Main Street, Bound Brook, NJ 08805. (201) 356-2000.

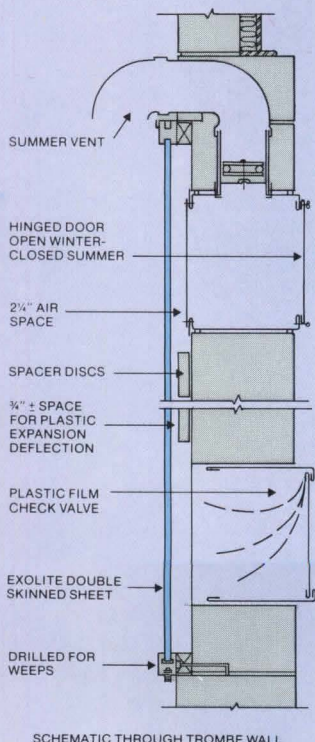

Architects: Banwell, White & Arnold, Inc.
Solar Engineering: Parallax, Inc. and Prof. Alvin O. Converse
Mechanical Engineering: R. D. Kimball Co.



A Partnership of Cyanamid Plastics, Inc. and Rohacryl, Inc.

Circle 42 on information card

Acronyms from page 71

- RANN**
Research Applied to National Needs,
National Science Foundation
- RCSHSB**
Red Cedar Shingle and
Handsplint Shake Bureau
- RIBA**
Royal Institute of British Architects
- R/UDAT**
Regional/Urban Design Assistance
Teams

S

- SAH**
Society of Architectural Historians
- SARA**
Society of American Registered
Architects
- SBA**
Standard Building Code
- SBCC**
Southern Building Code Congress
- SCUP**
Society for College and
University Planning
- SEA**
Solar Energy Association
- SEI**
Solar Energy Institute of America
- SERI**
Solar Energy Research Institute
- SHAF**
Solar Homes Association and
Foundation
- SMPS**
Society of Marketing
Professional Services
- SSRC**
Structural Stability Research Council

U

- UBC**
Uniform Building Code
- UCI**
Uniform Construction Index
- UIA**
Union Internationale d' Architects
- UIFA**
International Union of Women
Architects
- UL**
Underwriters Laboratories Inc.
- ULI**
Urban Land Institute

W

- WEF**
Wind Energy Foundation □

ARCHITECT: PROBLEM: SOLUTION:

Brooks Borg and
Skiles

Design an office
building that will
display low operat-
ing and mainten-
ance costs and
meet stringent
energy conserva-
tion guidelines.

Brick



For more information about
the design of the Federal
Home Loan Bank Building,
request a free copy of *Brick
In Architecture*, Volume 36,
Number 6 from Brick
Institute of America,
1750 Old Meadow Road,
McLean, Virginia
22101.



BRICK
INSTITUTE
OF AMERICA

Circle 43 on information card

**The
Consultant's
Consultant**

Lumina

For unique lighting
environments, custom
design, equipment, soft-
ware. Safe, low-power
Lasergraphics. New
York/ New England Dis-
tributor for **tivoli**

sparkling low-voltage
systems. Dealer inquiries
invited.

Lumina, Inc.
22 Wendell,
Cambridge, MA
(617) 492-6666



THE OFFICIAL SUPPLIER OF
DISCO-LIGHT LIGHTING SYSTEM
TO THE 1992 WINTER OLYMPICS
IN COOPERATION WITH
LARRY SILVERMAN MULTIPHASE
NEW YORK CITY

Circle 44 on information card

News About Joint Design & Joint Sealants

For reprints, copies of literature or information about any topics mentioned below, please write: Marketing Communications, Dept. AIA, Thiokol/Specialty Chemicals Division, P.O. Box 8296, Trenton, NJ 08650.

Thiokol LP® Polysulfide Base Sealants Offer 30-Year Track Record

Since 1947 building sealants based on Thiokol's LP polysulfide polymers have been specified by architects; and they continue to be the choice of architects and sealant applicators throughout the world.

Worldwide acceptance within the building trade of Thiokol LP polysulfide base sealants stems from more than 30 years of field performance, reliability and highly desirable sealant properties.

These properties include: excellent resistance to many types of oils and solvents; excellent resistance to aging, ozone, oxidation and sunlight; excellent adhesion to most common construction materials; and the ability to expand and contract with joint movement.

But the test of any sealant is actual performance. The buildings shown here are just a few examples of longevity in applications involving sealants based on Thiokol's polysulfide polymers.

We'll be happy to tell you about other applications. Write for details.



California Telephone & Telegraph Building
Albany, New York, sealed with Thiokol polysulfide base sealant, 1947



Lever House
New York, New York, sealed with Thiokol polysulfide base sealant, 1954



State Capitol Building
Richmond, Virginia, sealed with Thiokol polysulfide base sealant, 1962

ARCHITECTS *Did You Know . . .*

THAT the amount of movement in a joint is dependent on the length and composition (coefficient of linear expansion) of a panel section and the temperature gradient that is encountered.

THAT in designing joints, the proper width-to-depth ratio must be specified so that the width of the joint is consistent with the capability of the sealant, to endure the daily and seasonal extensions and compression cycles for prolonged periods.

THAT as joints expand and contract, the sealant's shape changes accordingly, but the volume of sealant remains constant.

THAT joints must be designed so that the compression and extension of the sealant will not exceed the movement capability of the sealant.

THAT the technical tips listed above are described in a 20 page brochure, "Joints Design Digest". Send for your copy.

Have A Question About Sealants?

If you have a question about Thiokol polysulfide base sealants—questions regarding adhesion, expansion, contraction, conditions for applying the sealant, specifications, past performance—write us. We'll be happy to help.

Yellow Pages' Index

Adaptive Use		Contract Information	89	Marketing	104
<i>see</i> : Historic Preservation	101	<i>see also</i> :		<i>see also</i> : Public Relations	108
A/E Selection	76	Construction Management	87	Masterspec	
<i>see also</i> :		Project Delivery	108	<i>see</i> : Specifications	111
Architect-Client Relations	77	Contracts and Documents	90	Meetings	104
Government Affairs—National	98	Education	93	Membership	105
Government Affairs—		<i>see also</i> :		The Octagon	105
State and Local	98	Careers in Architecture	83	Office Management	105
Affirmative Action	76	Continuing Education	87	Periodicals	106
<i>see also</i> : Women in Architecture	112	Educational Facilities	94	Posters	106
AIA	76	Energy	94	Practice	107
<i>see also</i> : The Octagon	105	Environmental Design	95	<i>see also</i> :	
Arbitration	77	<i>see also</i> :		Computer Applications	86
<i>see also</i> : Contract Information	89	Land Use	103	Financial Management	97
Architect-Client Relations	77	Urban Planning	112	Office Management	105
<i>see also</i> : A/E Selection	76	Environmental Education	96	Presentation Techniques	107
Architects	78	Ethics	96	Professional Development	
<i>see also</i> : Membership	105	Exhibits	96	<i>see</i> : Continuing Education	87
Architecture (General)	78	Filing Systems	97	Professional Interest Programs	107
Archives	79	Financial Management	97	Programming	108
Arts and Recreation	79	<i>see also</i> :		<i>see also</i> : Computer Applications	86
Audiovisual Materials	79	Computer Applications	86	Project Delivery	108
Awards	81	Office Management	105	Public Buildings	108
Barrier-Free Architecture	82	Practice	107	Public Relations	108
Bibliographies	82	Firesafety	98	<i>see also</i> :	
Building Costs	83	Funding	98	Architect-Client Relations	77
Building Evaluation	83	Government Affairs—National	98	Audiovisual Materials	79
Building Types	83	<i>see also</i> : A/E Selection	76	Marketing	104
Careers in Architecture	83	Government Affairs—		Publications Sales	110
<i>see also</i> :		State and Local	98	Railroad Stations	111
Continuing Education	87	<i>see also</i> :		Real Estate	111
Education	93	A/E Selection	76	Registration	111
Codes and Standards	84	Registration	111	Research	111
<i>see also</i> :		Guidebooks	100	Signs	111
Firesafety	98	Historic Preservation	101	Solar Energy	
Legal Concerns	103	Housing	101	<i>see</i> : Energy	94
Community Centers	84	Industrial Architecture	102	Specifications	111
Community Development	84	Insurance	102	<i>see also</i> : Working Drawings	112
<i>see also</i> : Urban Planning	112	Interiors	102	Transportation	111
Competitions	84	International Relations	102	Underground	111
Components, AIA	84	Joint Ventures	102	Urban Planning	112
Computer Applications	86	Justice Facilities	102	<i>see also</i> :	
<i>see also</i> :		Land Use	103	Community Development	84
Financial Management	97	<i>see also</i> :		Environmental Design	95
Programming	108	Environmental Design	95	Land Use	103
Construction Industry	87	Real Estate	111	Women in Architecture	112
Construction Management	87	Urban Planning	112	<i>see also</i> : Affirmative Action	76
<i>see also</i> :		Legal Concerns	103	Working Drawings	112
Contract Information	89	<i>see also</i> :		<i>see also</i> :	
Project Delivery	108	Codes and Standards	84	Presentation Techniques	107
Continuing Education	87	Contract Information	89	Specifications	111
		Library	103		
		<i>see also</i> : Audiovisual Materials	79		
		Lighting	104		

Directory of AIA Resources

A/E Selection

Architect/Engineer Government Contracting: A Manual (4-M718)

In loose-leaf format, this manual (1979) contains actual forms, documents, regulations, laws, guidelines and techniques used by public officials and design practitioners in A/E contracting. Prepared by Committee on Federal Procurement of A/E Services (COFPAES). \$95.

Available through Publications Fulfillment Office (626-7332).

Compendium: Architect Selection Laws (4-N509)

Contains laws of the 18 states that now have specific legislation regulating the selection of architects for public construction projects. Appendix contains a list of state agencies responsible for implementing these laws and the federal A/E (Brooks) procurement law. Free to members; \$5, nonmembers.

Available through Publications Fulfillment Office (626-7332).

Federal Marketplace: Are You Prepared? (2-M704)

75-page book describes the process of A/E selection and outlines opportunities for architects. New edition expected in 1981.

Available through Publications Fulfillment Office (626-7332).

Planning City Hall

20-page publication (1975) prepared for the International City Management Association under a grant from AIA, outlines AIA's preferred method of architect selection based on qualification in addition to other considerations relating to building construction. It is a useful tool when discussing A/E selection with state and local officials. Free.

Available through State Component Affairs Office (626-7386).

Working in Government: A Profile Study of the Architect as a Public Employee (2-M712)

40-page report (1978) prepared by AIA's architects in government committee. The information presented in this report is intended to give the general public a better understanding of the various functions performed by architects in government. Developed from a survey of more than 2,000 architects in government conducted in 1976, it provides a comprehensive profile of those persons practicing as architects in the public sector. \$5/\$6.

Available through Publications Fulfillment Office (626-7332).

For further information about A/E selection, contact the following offices: federal government—Federal Agency Liaison Office (626-7383); state government—State Components Affairs Office (626-7385); nongovernmental projects—Professional Interest Programs Office (626-7364).

Affirmative Action

A Directory of Minority Architectural/Engineering Firms (4-M709)

The directory (1978) prepared by AIA and the American Consulting Engineers Council (ACEC) lists both member and nonmember minority architectural and engineering firms nationwide. \$5 for AIA and ACEC members, \$10 for nonmembers.

Available through Publications Fulfillment Office (626-7332).

For further information about affirmative action, contact the Minority Resources Office, 626-7434.

AIA

AIA and Related Organizations (1-HBC3)

Chapter 3 (1972) of the Architect's Handbook of Professional Practice, this document explains AIA and its associated organizations, and outlines the roles of related professional societies. \$1.20/\$1.80.

Available through Publications Fulfillment Office (626-7332).

AIA Bylaws (6-N100)

40-page publication, updated annually by the secretary of the Institute, outlining the bylaws of AIA. Free.

Available through Publications Fulfillment Office (626-7332).

AIA Emblem for Printing

Instruction sheet regarding rules for use of AIA emblem. Two sheets of reproducible emblems in various sizes for use on letterheads, etc. Free. In limited quantities.

Available through Public Relations Department (626-7460).

AIA Headquarters Slide Show

50 color slides with script and cassette tape (1974). Past AIA President Archibald Rogers, FAIA, discusses AIA headquarters building and the Octagon. Free loan to AIA members only. *Available through Audiovisual Division, Library (626-7495).*

AIA Journal

Official magazine of AIA, published monthly except May and August, when

semimonthly. Subscription price included in AIA membership dues.

For subscription information for others, contact Circulation Department, AIA Journal (626-7327).

AIA Membership Directory (4-M136)

Annual alphabetical listing of AIA members, including addresses and chapter affiliations. Appendices include honorary members and fellows, component presidents, medals and awards, affiliated and associated organizations. \$10/\$60.

Available through Publications Fulfillment Office (626-7332).

AIA Memo

Newsletter, published twice a month, sent to the entire membership. Aims to keep members abreast of Institute programs, achievements, services, etc. Free.

Available through Public Relations Department (626-7465).

AIA National Convention

Annual conference for all AIA members, where officers are elected, product information displayed, workshops and seminars presented, etc. Location and registration fee vary.

Contact Convention Office (626-7395).

AIA Research Corporation

AIA/RC descriptive brochure. *Available through AIA/RC at AIA Headquarters (626-7500).*

AIA Tote Bag (4-M419)

The American Institute of Architects in bold black letters with AIA emblem on off-white heavy-duty cotton canvas. Washing instructions included. 10x13½x4½ inches. AIA members and components only. \$6 each.

Available through Publications Fulfillment Office (626-7332).

Annual Committee Reports

AIA committees report annually to the board of directors on their activities. Free. *Available through Office of Assistant Secretary (626-7502).*

A Celebration of Architecture (6-N826)

Flyer describing AIA's 1979 celebration program in which architects throughout the country encourage greater public understanding of what architecture is, how it can be enjoyed and how it comes to be. Free.

Available through Public Relations Department (626-7460).

Code of Ethics and Professional Conduct (6-J330)

Explains the Institute's canons, ethical standards and rules of conduct. *Available through Office of Assistant Secretary (626-7502) or Publications Fulfillment Office (626-7332).*

Committees: The "Pulse" of All AIA Activities

Eight-page special issue of the *Memo* (Jan. 1980) describing the national AIA committee structure, with emphasis on the open committees. Includes an insert on professional interest committees with registration form. Free.

Available through *Public Relations Department* (626-7460).

Minutes of the Board of Directors, Minutes of the Executive Committee

Published minutes of the board and executive committee meetings are distributed to all component officers and chapter offices, and are available for consultation by the membership.

Available through *Office of Assistant Secretary* (626-7502).

No Little Plans

The history of AIA and its services today, featuring Elmer Botsai, FAIA, Wolf von Eckardt, Hon. AIA, and Winfield Rankin, Hon. AIA; includes material drawn from the AIA archives and library. 16mm color slide-film, 18 minutes. Free loan to AIA components and chapters.

Available through *Audiovisual Division, Library* (626-7495).

Organizational Directory (4-P105)

Annual directory of AIA officers and committees; component officers and executives. Shows organizational structure of Institute. Includes a list of related architectural organizations. Free to component officers and executives. \$6 to AIA members only.

Component officers and executives contact the *Component Services Office*, (626-7376). Members contact *Publications Fulfillment Office* (626-7332).

Policy Statements (6-N103)

General statements issued by the board of directors that concern architects or architecture and relationships outside AIA. Free.

Available through the *Office of Assistant Secretary* (626-7502).

Program and Membership Services Budget

Review of Institute budget by department, with descriptions of all Institute programs. Issued annually after December board meeting. Free.

Available through *Executive Office* (626-7312).

Publications Marketing/Sales

AIA sells documents, books, audiovisual materials, etc., to architects, components and the public. Members and components are entitled to varying discounts, depend-

ing on nature of the publications.

Contact *Publications Marketing Sales Office* (626-7474).

Publications Price List and Order Form (6-N702)

List of AIA documents and forms, books, manuals, audiovisual materials, etc., available for sale through AIA. Free.

Available through *Publications Fulfillment Office* (626-7332).

Report of the Board

Annual report of AIA. Free.

Available through *Public Relations Department* (626-7460).

Rules of the Board of Directors (6-N102)

75-page publication prepared by the secretary of the Institute, listing the formally adopted rules regulating conduct of AIA. Free.

Available through *Office of Assistant Secretary* (626-7502).

Fulfillment Office (626-7332).

Summary of the Program and Membership Services Budget

Summary of AIA's budget showing less detail than the program and membership services budget. It makes the budget easier to understand. Issued annually.

Free.

Available through *Executive Office* (626-7312).

For further information about AIA in general, contact the *Public Relations Department*, 626-7460.

Arbitration

AIA Adoption of the AAA Construction Industry Arbitration Rules

Four-page publication (1975) that explains the conversion, in 1966, from AIA's Standard Form of Arbitration Procedure to the Construction Industry Arbitration Rules. Free.

Available through *Documents Office* (626-7454).

Construction Contract Disputes: How They May Be Resolved Under the Construction Industry Arbitration Rules

Pamphlet prepared by the American Arbitration Association that answers arbitration questions. Free.

Available through *Documents Office* (626-7454).

Construction Industry Arbitration Rules

10-page publication (1979) of the American Arbitration Association containing arbitration rules and procedures. Free.

Available through *Documents Office* (626-7454).

For further information about arbitration, contact the *Documents Office*, 626-7454.

Architect-Client Relations

American Institute of Architects**Advertising**

Leaflet describing former national advertising campaigns, ads for local chapter use, public service radio and television spots. Free.

Available through *Public Relations Department* (626-7460).

Client's Guide to Architectural Services

For persons who are about to undertake an enterprise, making the design and construction of a building (1978). Published by the office practice committee, Boston Society of Architects. \$1.50 includes handling.

Available through the *Boston Society of Architects, 320 Newbury St., Boston, Mass. 02115* (617) 267-5175.

Fulfillment Office (626-7332).

Nobody Wants to Listen to Your Problems — Right? Wrong (6-N814)

Companion pamphlet to 1975 ad series encouraging clients to "plan now." ("One of these days you're going to build . . .")

"When you think it's too soon to call an architect . . ." and "There's a way to save on your next building.") Consists of case studies demonstrating advantages of hiring an architect for planning although construction time is indefinite. Free.

Available through *Public Relations Department* (626-7460).

Selling Architectural Services (3-S207)

Cassette (1973) showing how the architect can conduct a practice in a professional and more prosperous manner by using effective marketing techniques.

\$9/\$10.

Available through *Publications*

Fulfillment Office (626-7332).

Selling Architectural Services II (3-S218)

This cassette (1975) examines the person-to-person selling process. It focuses on how to understand and work with your client's problem, achieving a mutually beneficial client-architect relationship. \$10/9. Set of two cassettes (3-SAS), \$17.25/\$19.

Available through *Publications*

Fulfillment Office (626-7332).

You and Your Architect (4-N802)

Publication (1980) by David R. Dibner, FAIA, that answers client questions about the selection and compensation of an architect. Outlines responsibilities of the architect and the client during construction. Up to 25 copies free; \$10 per 100.

Available through *Publications*

Fulfillment Office (626-7332).

For further information about the role of the architect, contact the Public Relations Department, 626-7460.

Architects

Architects/Architecture

(1977, International Masonry Institute) 16mm color film, 36 minutes. Four American architects discuss architectural design and the opportunities and problems facing students and practitioners. Features Warren Cox, FAIA; George Hartman, FAIA; Ulrich Franzen, FAIA, and Philip Johnson, FAIA, and shows examples of their work. Rent \$15 to AIA members only.

Available through Audiovisual Division, Library (626-7495).

Biographical Information on Architects

The library will attempt to provide biographical information on individual architects, using reference sources such as the Baldwin Memorial Archive of American Architects.

Contact the Library (626-7493).

Conversation with an Architect (4-Q118)

16mm color sound film, 28 minutes (1975). Discusses the role of the architect in today's society. Shows architects at work on a planned housing development, a school, a factory and an urban area. Free loan to AIA members and components only.

Available through Audiovisual Division, Library (626-7495).

Conversation with an Architect

Two-page flyer describing theme and subject matter of 1975 film by same title. Free.

Available through Public Relations Department (626-7460).

Do It with an Architect. Bumper sticker, \$1 each.

Available through Association of Student Chapters/AIA at AIA Headquarters (626-7472).

First Principles

16mm color film (18 minutes) with Vincent Scully, narrator. Discussion of Louis I. Kahn's philosophy of design with examples of his masonry work in conjunction with Roman architecture. Rent \$15 to AIA members.

Available through Audiovisual Division, Library (626-7495).

Frank Lloyd Wright Crayon Drawing "Sahuaros"

Numbered edition serigraph (total edition 200); image size 12¼ x 13¼ inches, each print initialed on white border by Mrs. Frank Lloyd Wright, overall size 17½ x 18¼ inches, mailable, \$300 postpaid.

Available through Arizona Architects Foundation, Inc., 1121 N. Second St., Phoenix, Ariz. 85004

Harold Sterner: Architect and Artist

Exhibition catalogue (1978) on Harold Sterner, and the interrelationship between his art and architecture. Illustrated. \$3. Available through the Octagon, 1799 New York Ave. N.W., Washington, D.C. 20006 (638-3105).

Mr. Wright and the Johnsons of Racine, Wis.

Reprint from *AIA Journal* (1979) of an informal talk by Samuel C. Johnson on Frank Lloyd Wright and comments about the Wright architecture commissioned by his father. Free.

Available through Director, Design and Environment Programs (626-7363).

S. E. Rasmussen

Sixty-seven color slides (1979) with cassette tape featuring famed Danish architect and town planner S. E. Rasmussen. Rasmussen narrates the 24-minute program, which is based on his AIA medal-winning book, *Experiencing Architecture*. Free loan; AIA members only.

Available through Audiovisual Division, Library (626-7495).

The Travel Sketches of Louis I. Kahn

Sixty-three-page exhibition catalog (1977) including illustrations and discussion of 91 travel sketches of Louis I. Kahn, dating from 1913 to 1959. Prepared by the Pennsylvania Academy of the Fine Arts. 31 black and white illustrations, four color plates. \$8 postpaid.

Available through the Octagon, 1799 New York Ave. N.W., Washington, D.C. 20006 (638-3105).

William Thornton: A Renaissance Man in the Federal City

Fifty-eight-page exhibition catalog (1976) for exhibition, held at the Octagon, on the first architect of the United States Capitol and the Octagon. Prepared by David N. Yerkes, FAIA, and Elinor Stearns; 46 black and white illustrations. \$3.75 postpaid.

Available through the Octagon, 1799 New York Ave. N.W., Washington, D.C. 20006 (638-3105).

Detailed biographical information on individual architects may be obtained through the Library, 626-7493.

Architecture (General)

Art in Architecture (6-N828)

Pamphlet (1979) providing a brief overview of the history of art in architecture, ground rules and possible sources for funding. Free.

Available through Public Relations Department (626-7460).

Books on Architecture/Related Subjects

Alphabetical listing of over 3,000 books used by the architectural profession and of interest to the public, giving title, author, publisher and price of books available from hundreds of publishers. Revised annually in October. Free. Send \$3 for postage and handling.

Available through St. Louis Chapter/AIA, 919 Olive St., St. Louis, Mo. 63101, (314) 621-3484.

Celebrating American Architecture (4-N825)

Slide show (1979) designed to provide general audiences with a better understanding of American design and architecture. Eighty color slides of 1979 national honor award and 25-year award winning buildings depicted. Script provides introduction and brief general description of the structures. \$20 prepaid.

Available through Public Relations Department (626-7460) or Publications Fulfillment Office (626-7332).

Conversation with an Architect

Two-page flyer describing theme and subject matter of 1975 film by same title. Free.

Available through Public Relations Department (626-7460).

Experience of Architecture in the Southwest

Tape cassette with 55 slides of examples of architecture in New Mexico, including ancient Indian and present day structures. Free loan to AIA members.

Available through Audiovisual Division, Library (626-7495).

Historic Buildings and Contemporary Structures

Two books featuring 18 historical structures and 12 contemporary buildings, complete with slides. Authored by members of the Women's Architectural League, with an architect consultant for each building, and edited by George McCue, Hon. AIA, and Robert Vickery, AIA. *Historic Buildings* features 80 slides, \$28 postpaid.

Contemporary Structures 40 slides, \$18 prepaid. Historical outline of events, \$2 prepaid.

Available through *St. Louis Chapter/AIA*, 19 Olive St., St. Louis, Mo. 63101, (314) 621-3484.

How Architecture Speaks: Program Package Two (4-N808)

8 slides, guidelines, script and quiz sheets (1974) that show people how architecture "speaks" through form, color, scale, texture, materials. \$18 prepaid. Available through *Publications Fulfillment Office* (626-7332).

The Practice of Architecture in the U.S.A.

Four-page leaflet (1977) that outlines AIA, schools of architecture, registration, practice, etc., for foreign architects and students. Free.

Available to non-U.S. residents only through *Office of Assistant Secretary* (26-7502).

For further information about architecture in general, contact either the *Public Relations Department*, 626-7460, or the *Library*, 626-7493.

Archives

Design Competitions Archive

AIA library competitions archive is a repository for the documentary material (excluding drawings) generated by architectural design competitions. Sponsors and/or professional advisers of recent competitions should send the archive copies of competition announcements, press releases, photographs of winning designs, publications, etc. Drawings should be donated to local libraries or archives. Contact the *Library* (626-7493).

Selections from the AIA Architectural Archives

Catalog (1977) containing highlights of the extensive AIA architectural archives. \$3.

Available through the *Octagon*, 1799 New York Ave. N.W., Washington, D.C. 20006 (638-3105).

Arts & Recreation

American Endless Weekend (2-M151)

4-page publication (1973) by C. Ray Smith, AIA, that treats recreation problems and planning in America. Prepared

for the AIA committee on architecture for the arts and recreation. \$5/\$6.

Available through *Publications Fulfillment Office* (626-7332).

Mobile Recreation (AIA Committee on Architecture for the Arts and Recreation)

Eighty color slides (1979) with cassette tape depicting a mobile system for providing many types of recreational, cultural and educational activities for inner city youths. Free loan.

Available through *Audiovisual Division, Library* (626-7495).

For further information about arts and recreation facilities, contact the *Professional Interest Programs Office*, 626-7429.

Audiovisual Materials

AIA Headquarters Slide Show

50 color slides, with script and cassette tape (1974). Past AIA President Archibald Rogers, FAIA, discusses the AIA headquarters building and the Octagon. Free loan to AIA members only.

Available through *Audiovisual Division, Library* (626-7495).

All Weather Construction

65 color slides with tape cassette and script explaining techniques for cold weather masonry construction. Free loan to AIA members.

Available through *Audiovisual Division, Library* (626-7495).

Architects/Architecture

(1977, International Masonry Institute) 16mm color film, 36 minutes. Four American architects discuss architectural design and the opportunities and problems facing students and practitioners. Features Warren Cox, FAIA; George Hartman, FAIA; Ulrich Franzen, FAIA, and Philip Johnson, FAIA, and shows examples of their work. Rent \$15 to AIA members only.

Available through *Audiovisual Division, Library* (626-7495).

Architectural Career Awareness Package (3-M401)

80 color slides with script for use by high school counselors or architects lecturing young groups of prospective architects. Includes "Architecture in Community and Junior Colleges," "Architecture Schools in North America" and assorted pamphlets. \$27/\$30.

Available through *Association of Student Chapters/AIA at AIA Headquarters* (626-7472) or *Publications Fulfillment Office* (626-7332).

Architecture and Your Life (4-Q101)

35mm, 50 frame color filmstrip, with teacher's guide. Discusses the use of

architecture by man and the unprecedented responsibility of today's citizen for deciding upon the quality of this environment. \$5.

Available through *Publications Fulfillment Office* (626-7332).

Architecture Internship/Associate Membership

Cassette and slides looking into the experiences of architectural interns, with discussion of internship opportunities and associate membership in AIA. 10 minutes.

Available through *Professional Development Office* (626-7353).

Audiovisual Materials

Four-page annotated list (1979) of audiovisual materials available for loan and/or sale from the AIA library. Free loan.

Available through the *Library* (626-7493).

Beating the Averages

Raymond Burr narrates the 16mm color film (26 minutes) in which handicapped people show how architectural barriers affect their lives. Free loan.

Available through *Audiovisual Division, Library* (626-7493).

Bibliographies of Audiovisual Materials Available Through Sources Other Than AIA

The audiovisual librarian will supply on request bibliographies of A/V materials on various architecture and planning topics. Materials listed have not been screened.

Contact *Audiovisual Division, Library* (626-7493).

Building Evaluation (3-S212)

Cassette and booklet (1974) explain how to evaluate existing environments for better programming in relation to human needs. \$9/\$10.

Available through *Publications Fulfillment Office* (626-7332).

A Child Went Forth

16mm color film (28 minutes) focusing on the debilitating effects of inner-city schools on children, and providing a contrast with new innovative projects for school architecture. Free loan.

Available through *Audiovisual Division, Library* (626-7495).

Conversation with an Architect

16mm color sound film, 28 minutes (1975). Discusses the role of the architect in today's society. Shows architects at work on a planned housing development, a school, a factory and an urban area.

Free loan to AIA members and components only; \$95 for used copy in good condition.

Available through Audiovisual Division, Library (626-7495).

**Designing a Nation's Capitol—
Competition: 1792**

87 black and white slides with script. Includes competitors and their drawings for the 1792 competition for the U.S. Capitol. Free loan to AIA members.

Available through Audiovisual Division, Library (626-7495).

**Designing Your Brochure as an Aid in
Marketing Your Services (3-S224)**

This one-hour cassette (1976) tells you how to gear your brochure to your desired market by making it convey your firm's personality, your ability to take care of the client, your problem-solving ability, the range of your services, etc. The contents of an "ideal" brochure are outlined. \$9/\$10.

*Available through Publications
Fulfillment Office (626-7332).*

Designscape

160 color slides with reel-to-reel synchronized tape (1975). A visually delightful view of many of the old and new "designs" we see all around us. Free loan to AIA members only.

Available through Audiovisual Division, Library (626-7495).

Downtowns for People

16mm color film, 26 minutes (1972) showing examples of European and American downtown areas from the pedestrian's viewpoint. Free loan to AIA members only; no sale.

Available through Audiovisual Division, Library (626-7495).

**Environments for People: Program
Package 5 (4-N812)**

Eighty slides, introduction, script and suggestions for use (1976). Explains how architects provide for basic human needs (shelter, privacy, personalization, socializing mobility, communication) in their design of the human environment. \$20 prepaid.

*Available through Publications
Fulfillment Office (626-7332).*

**Experience of Architecture in the
Southwest**

Tape cassette with 55 slides of examples of architecture in New Mexico, including ancient Indian and present day structures. Free loan to AIA members.

Available through Audiovisual Division, Library (626-7495).

Film Loans

The audiovisual librarian has a collection

of films on architecture and planning subjects, most of which are available for free loan to AIA members and the general public. The only charge is return postage via UPS or insured mail.

Contact Audiovisual Division, Library (626-7495).

First Principles

16mm color film (18 minutes) with Vincent Scully, narrator. Discussion of Louis I. Kahn's philosophy of design with examples of his masonry work in conjunction with Roman architecture. Rent \$15 to AIA members.

Available through Audiovisual Division, Library (626-7495).

**How Architecture Speaks: Program
Package 2 (4-N808)**

43 slides, guidelines, script and quiz sheets (1974) that show people how architecture "speaks" through form, color, scale, texture, materials. Quiz tests people's reactions to structures. \$18 prepaid.

*Available through Publications
Fulfillment Office (626-7332) or Public
Relations Department (626-7460).*

**Intern-Architect Development Program
(IDP)**

Cassette and slides of an in-depth review of IDP concepts, participation and operation, including the AIA supplementary education program and advisory system. 20 minutes. Free loan to AIA members/components.

Available through Professional Development Office (626-7353).

Lafayette R/UDAT

16mm color film, 25 minutes (1978), documents the AIA R/UDAT visit to Lafayette, La. Free loan to AIA members.

Available through Audiovisual Division, Library (626-7495).

**Los Angeles: 20th Century American City
(Environmental Communications)**

Eighty-seven color slides with booklet. Explores important aspects of new trends and problems in contemporary urban development: urban sprawl, low-density ghetto, freeway systems, leisure facilities, land use patterns. Rent \$15 to AIA members only.

Available through Audiovisual Division, Library (626-7495).

The Management of Time (3-S216)

Cassette explaining how to accomplish more in less time. A guide to organizing and using time efficiently and effectively. 45 minutes. \$9/\$10.

Available through Publications Fulfillment Office (626-7332).

**Mobile Recreation (AIA Committee on
Architecture for the Arts and Recreation)**

Eighty color slides (1979) with cassette tape depicting a mobile system for provid-

ing many types of recreational, cultural and educational activities for inner city youths. Free loan.

Available through Audiovisual Division, Library (626-7495).

No Little Plans

The history of the AIA and its services today, featuring Elmer Botsai, FAIA; Wolf von Eckardt, Hon. AIA, and Winfield Rankin, Hon. AIA; includes material drawn from the AIA archives and library. 16mm color slide-film, 18 minutes. Free loan to AIA components and chapters.

Available through Audiovisual Division, Library (626-7495).

Octagon Slide Set

Five color slides of the Octagon. \$2 postpaid.

Available from the Octagon, 1799 New York Ave. N.W., Washington, D.C. 20006 (638-3105).

Passive Solar Design (4-N833)

Set of 80 slides and script (1980) illustrating passive solar design principles and their applications through diagrams and representational building samples.

Regional and climatic considerations are evident in the examples used. Intended for a nontechnical audience. \$22 prepaid. *After Oct. 1, 1980, available through Public Relations Department (626-7460) or Publications Fulfillment Office (626-7332).*

S. E. Rasmussen

Sixty-seven color slides (1979) with cassette tape featuring famed Danish architect and town planner S. E. Rasmussen. Rasmussen narrates the 24-minute program, which is based on his AIA medal-winning book, *Experiencing Architecture*. Free loan to AIA members only.

Available through Audiovisual Division, Library (626-7495).

R/UDAT Films

Films of some previous R/UDATs are available on loan.

Available through the Audiovisual Division, Library (626-7495).

**Scope of Services of Interior Architecture
(AIA Committee on Interior Architecture)**

Two-hundred color slides (1980) with script describing the array of services architects provide in interior design, relating these services to AIA Document B171, "Standard Form of Agreement for Interior Design Services." Show designed for two projectors and two screens, but can be shown in a single projector and screen.

Free loan to AIA members only.

Available through Audiovisual Division, Library (626-7495).

Selling Architectural Services (3-S207)
Cassette (1973) shows how the architect can conduct a practice in a professional and more prosperous manner by using effective marketing techniques. \$9/\$10.

Available through Publications Fulfillment Office (626-7332).

Selling Architectural Services II (3-S218)
This cassette (1975) examines the person-to-person selling process. It focuses on how to understand and work with your client's problem, achieving a mutually beneficial client-architect relationship. \$9/\$10.

Available through Publications Fulfillment Office (626-7332).

Setting Up an Architectural Firm (3-S229)
Cassette covering the wide range of considerations in setting up and running an architectural firm; including organization, business management, legal considerations, information resources, office machines. 90 minutes. \$9/\$10.

Available through Publications Fulfillment Office (626-7332).

Shelter (Environmental Communications)
100 color slides with booklet. Depicts various shelters from around the world; includes hand-built houses, yurts, domes, tents, cottages, barns and free-form sculptured dwellings. Rent \$15 to AIA members only.

Available through Audiovisual Division, Library (626-7495).

Slide Loans

The audiovisual librarian maintains a slide collection of approximately 12,000 slides. These slides are primarily on American architecture, and include documentation of most AIA award-winning projects. No list is available of the collection, but the A/V librarian will select slides on specific subjects. Free loan to AIA members.

Contact Audiovisual Division, Library (626-7495).

Solar Architecture (Environmental Communications)

Seventy color slides with booklet. Shows in detail more than 20 existing structures that effectively use the sun's energy. Illustrates buildings with passive solar heating and buildings with various types of collectors and storage systems. Rent \$15 to AIA members only.

Available through Audiovisual Division, Library (626-7495).

Something This Good Can Last Forever
Three 30-second television spots (1975), stressing importance of land use planning and showing a variety of urban and rural scenes to demonstrate benefits of intelli-

gent land use. One spot is on George Washington as surveyor. AIA requires knowledge of stations using spots. Free. *Available through Public Relations Department (626-7460).*

Spaces for the Species

30-minute slide synchronized cassette tape presentation (1975) summarizing users' responses to various environments, such as a hotel, a school, an urban plaza and a shopping center. Free loan to AIA members only.

Available through Audiovisual Division, Library (626-7495).

Stations

16mm color film, 28 minutes (1974). Shows many of the interesting and innovative uses being made of old railroad stations, in order to preserve these landmarks. Rent \$15 to AIA members only.

Available through Audiovisual Division, Library (626-7495).

Sun People

Examples of passive solar homes in northern New Mexico—owners and architects speak about their experiences with passive solar. 16mm color film, 16 minutes. Rent \$15 to AIA members.

Available through Audiovisual Division, Library (626-7495).

We Have to Be Able to Do It Ourselves

16mm color film discussing community design centers—what they are, what they do and why they work, featuring Philadelphia, Cleveland, New Orleans and San Francisco. Free loan.

Available through Audiovisual Division, Library (626-7495).

What Do They Have in Common?

Program Package 9 (4-N604)
Slide show of contemporary American architecture designed by women. Included are informational handouts and guidelines for suggested use. The 80 slides run the gamut from solar homes to urban hospitals, from Manhattan to California. Can be shown without narration. \$20.

Available through Public Relations Department (626-7460) or Publications Fulfillment Office (626-7332).

Wilson R/UDAT

16mm color film, 25 minutes (1974). Documents the AIA Regional/Urban Design Assistance Team visit to Wilson, N.C. Free loan to AIA members only.

Available through Audiovisual Division, Library (626-7495).

For further information about audio-tape cassettes, contact the Professional Development Programs Office, 626-7354. Questions regarding film loans and audiovisual materials in general should be directed to the Audiovisual Division, Library (626-7495).

Awards

AIA/ACSA Award for Excellence in Architectural Education

Annually awarded for excellence in teaching architectural design or history. Nominators must be colleagues, students or former students of the candidate.

Contact Awards Division, Office of Assistant Secretary (626-7390).

AIA/AFL-CIO Joint Craftsman Award Program

Biennial awards recognizing outstanding workmanship and the display of interest and ingenuity by the tradesman. Awarded to any journeyman or apprentice member of any of the building and construction trade unions of AFL/CIO.

Contact Awards Division, Office of Assistant Secretary (626-7390).

AIA Honor Awards 1981 (6-N602)

Brochure describing the programs, including eligibility requirements, submission procedures, entry dates and fees, etc. Contains a tear-off entry slip. Free.

Contact Awards Division, Office of Assistant Secretary (626-7390).

AIA Library Cross-Referenced Awards File

All AIA honor and merit awards have been indexed by date, place, architect, name of project and building type. The library staff can answer questions such as how many houses in Chicago have won AIA awards, etc.

Contact the Library (626-7493).

Architectural Firm Award

Highest honor bestowed to a firm by the Institute. Awarded annually.

Contact Awards Division, Office of Assistant Secretary (626-7390).

Celebrating American Architecture (4-N825)

Set of 80 slides depicting 1979 national honor award and 25-year award winning buildings. Script is included to provide brief descriptions of the structures and their award-winning qualities. \$20 pre-paid.

Available through Publications

Available through Publications Fulfillment Office (626-7332).

Concrete Reinforcing Steel Institute Design Awards Program

Biennial program sponsored by CRSI and open to site-cast reinforced concrete structures of all types. Material describing the design awards program, free.

Available through the Awards Division, Office of Assistant Secretary (626-7390).

Guidelines for Component Award Programs

This 12-point guideline developed by the committee on design was reviewed and shaped jointly by the committees of practice and design and component affairs. Free.

Available from director of Design and Environment Programs (626-7363) or Administrator, Component Affairs (626-7478).

Homes for Better Living Awards

Brochure describing the annual award program open to custom-designed houses, merchant-built houses and multifamily housing in the U.S. and its possessions. Sponsored by AIA in conjunction with *Housing* magazine. Contains eligibility requirements, submission procedures, entry dates, etc., and a tear-off entry slip. Free.

Available through Awards Division, Office of Assistant Secretary (626-7390).

Information for Honor Award Program Entrants

Descriptive information, including a check list, on how to prepare binders and forms for entry into AIA honor award programs, current and extended use. Automatically sent to all entrants who submit entry slips and checks for the program. Free.

Available through Awards Division, Office of Assistant Secretary (626-7390).

Institute Honors

Brochure describing the AIA program that recognizes distinguished achievements in the fine arts, industrial arts, architectural criticism and allied professions with the award of annual medals. Contains submission procedures, nomination forms, etc. Free.

Available through Awards Division, Office of Assistant Secretary (626-7390).

Library Buildings Award Program

Awards given for libraries designed in the U.S. or abroad by American architects. Sponsored by AIA in conjunction with the American Library Association. Libraries are judged in four categories: academic, public, school and state. Biennial.

Contact Awards Division, Office of Assistant Secretary (626-7390).

List of Honor and Award of Merit Recipients

Chronological list of all the projects that have won AIA honor awards and awards of merit, including location and architect(s). Free.

Available through Awards Division, Office of Assistant Secretary (626-7390).

Louis Sullivan Award for Architecture

Brochure describing the biennial award for projects using masonry. Sponsored by International Union of Bricklayers and Allied Craftsmen and administered by AIA. Contains eligibility requirements, submission procedures, entry dates, etc., and a tear-off entry slip. Free.

Available through Awards Division, Office of Assistant Secretary (626-7390).

Naval Facilities Engineering Command Awards Program

Includes constructed architectural projects either for the Navy or other government agencies, so long as design and construction were administered by NAVFAC. Projects may be submitted in various categories for naval facilities. Biennial.

Contact Awards Division, Office of Assistant Secretary (626-7390).

Red Cedar Shingle & Handsplit Shake Bureau Design Awards

To honor architects demonstrating design excellence and significant functional or esthetic uses of cedar shingles or shakes. Annual.

Contact Awards Division, Office of Assistant Secretary (626-7390).

Reynolds Aluminum Prize for Architectural Students

Brochure describing the annual award program open to students who have completed two years of architectural school. Sponsored by Reynolds Metals Co. and administered by AIA. Contains eligibility requirements, submission procedures, entry dates, etc. Free.

Available through Awards Division, Office of Assistant Secretary (626-7390).

R. S. Reynolds Memorial Award

Brochure describing the annual international award for architecture using aluminum. Sponsored by Reynolds Metals Co. and administered by AIA. Contains eligibility requirements, submission procedures, entry dates, etc., and a tear-off entry slip. Free.

Available through Awards Division, Office of Assistant Secretary (626-7390).

Slide Loans

The audiovisual librarian maintains a slide collection of approximately 12,000 slides. These slides are primarily on American architecture, and include documentation of most AIA award-winning projects. No list is available of the collection, but the A/V librarian will select slides on specific subjects. Free loan to AIA members.

Contact Audiovisual Division, Library (626-7495).

For further information about award programs in general, contact the Awards

Division, Office of Assistant Secretary, 626-7390.

Barrier-Free Architecture

Beating the Averages

Raymond Burr narrates the 16mm color film (26 minutes) in which handicapped people show how architectural barriers affect their lives. Free loan.

Available through Audiovisual Division, Library (626-7495).

Designing for the Physically Handicapped

Coordinates UBC and OSHA and other federal requirements. By James G. Burr, AIA. \$8 postpaid.

Available through Arizona Society of Architects/AIA, 1121 N. Second St., Phoenix, Ariz. 85004, (602) 257-1924.

Into the Mainstream: A Syllabus for a Barrier-Free Environment (3-M132)

Forty-four-page report (1975) by Stephen Kliment, FAIA, containing practical information on how a community can achieve a barrier-free environment. \$2.75/\$3.

Available through Publications Fulfillment Office (626-7332).

For further information about barrier-free architecture, contact the Codes & Standards Office, 626-7453.

Bibliographies

Bibliographies of AIA Library Holdings and Periodical Articles

The library staff will prepare on request bibliographies of library books and/or periodical articles on specific subjects or building types. Members can identify books they wish to borrow from these lists. Free. Library has no photocopying facilities.

Contact the Library (626-7493).

Bibliographies of Audio-Visual Materials Available Through Sources Other Than AIA

The audiovisual librarian will supply on request bibliographies of A/V materials on various architecture and planning topics. Materials listed have not been screened.

Contact Audiovisual Division, Library (626-7495).

Bibliography of Bibliographies

Four-page list (1978) of subject bibliographies compiled by the library staff. Contains approximately 200 subjects

on which bibliographies of the library's holdings and/or periodical articles have been prepared. Free.

Available through the Library (626-7493).

Environmental Education Teaching Tools

Forty-page annotated catalog (1975) prepared by the environmental education committee, listing information on resources (books, games, films, etc.) for environmental education. Free.

Available through the Director, Environmental Education (626-7573).

Environmental Impact Statements

Bibliography

Four-page selected and annotated bibliography (1975) prepared by the AIA committee on architecture for commerce and industry. Free.

Available through the Library (626-7493).

Recent Accessions

Bimonthly list of recent library acquisitions, arranged by subject. \$1/year.

Available through the Library (626-7493).

Value Engineering and Life Cycle

Bibliography

Four-page selected and annotated bibliography (1975) prepared by the AIA committee on architecture for commerce and industry. Free.

Available through the Library (626-7493).

Building Costs

Life Cycle Cost Analysis: A Guide for Architects (2-M708)

Provides architects, engineers and clients with a straightforward and usable technique allowing them to consider all relevant economic consequences of design decisions (1978). A primer prepared by the life cycle cost analysis task force of AIA. \$8/\$10.

Available through Publications Fulfillment Office (626-7332).

Life Cycle Cost Analysis 2: Using It in Practice (2-M713)

Responds to the critical question: Where in the planning and design process can the life cycle cost analysis technique be effectively used? (1978.) Provides guidelines for selecting application areas and a number of case study applications, as well as commentary on the planning and design process. In conjunction with the first life cycle guide, this publication presents an introduction to the life cycle cost analysis technique and a picture of its

current uses in practice. \$14.40/\$18.

Available through Publications Fulfillment Office (626-7332).

Value Engineering and Life Cycle Bibliography

Four-page selected and annotated bibliography (1975) prepared by the AIA committee on architecture for commerce and industry. Free.

Available through the Library (626-7493).

For further information about building costs in general, contact the Practice Department, 626-7457.

Building Evaluation

Building Evaluation (3-S212)

Cassette explaining how to better meet human needs in design through evaluation of existing environments. 45 minutes. \$9/\$10.

Available through Publications Fulfillment Office (626-7332).

Building Types

Bibliographies of AIA Library Holdings and Periodical Articles

The library staff will prepare on request bibliographies of library books and/or periodical articles on specific subjects or building types. Members can identify books they wish to borrow from these lists. Free. Library has no photocopying facilities.

Contact the Library (626-7493).

Spaces for the Species

Thirty-minute slide synchronized cassette tape presentation (1975) summarizing users' responses to various environments, such as a hotel, a school, an urban plaza and a shopping center. Free loan to AIA members only.

Available through Audiovisual Division, Library (626-7495).

Careers in Architecture

Architectural Career Awareness Package (3-M401)

Eighty color slides with script for use by high school counselors or architects lecturing groups of prospective architects. Includes "Architecture in Community and Junior Colleges," "Architecture Schools in North America" and assorted pamphlets. \$27/\$30.

Available through Association of Student Chapters/AIA at AIA Headquarters (626-7472), or Publications Fulfillment Office (626-7332).

Architectural History Syllabus

A collection of history notes and tips and pointers for candidates preparing for the history portion of the equivalency examination. \$15, including tax and postage. *Available through Cabrillo Chapter/AIA, 121 Linden Ave., Long Beach, Calif. 90802, (213) 432-9817.*

Career Alternatives (6-N209)

Prepared by the architects in industry committee, this pamphlet discusses expanding opportunities for architects in nontraditional careers. Free.

Available through Publications Fulfillment Office (626-7332).

Career Profile Architect (6-N207)

Publication (1980) aimed at the intermediate and high school students who want general information on the profession of architecture. It provides information on education, internship, salaries, practice, and a list of reading material and sources for more answers. Free.

Available through Education Office (626-7349) or Publication Fulfillment Office (626-7332).

Careers in Architecture (1-HBC4)

Chapter 4 (1972) of the Architect's Handbook of Professional Practice, this document covers the architect's profession, education and training; the architect in practice; AIA; Association of Collegiate Schools of Architecture; National Architectural Accrediting Board, and the National Council of Architectural Registration Boards. \$1.20/\$1.80.

Available through Publications Fulfillment Office (626-7332).

Counseling for Architectural Careers

Students desiring basic architectural career information are counseled by the Education and Professional Development Department staff. Counseling may be in person or by letter.

Contact Education Office (626-7349).

What Do They Have in Common?

Program Package 8 (4-N604)

An 80-slide sampling of contemporary American architecture, from solar homes to urban hospitals from Manhattan to California—all designed by women. Package includes informational handouts and guidelines for suggested use, is appropriate for career guidance or public awareness presentations, can be shown without a narrator. \$20.

Available through Publications Fulfillment Office (626-7332) or Public Relations Department (626-7460).

For further information about careers in architecture, contact the Education Office, 626-7349.

Codes & Standards

Building Codes and Standards List

Annual comprehensive list of nationally used codes and standards, including publishers, addresses and prices. Free.

Available through Codes and Standards Office (626-7456).

Developing Computer-Based Systems for Building Codes

A report on an exploratory research effort funded by the National Science Foundation, conducted by AIA Research Corporation. This is a study of the implications of computer technology on building regulations. \$4.

Available through AIA Research Corporation, at AIA headquarters (626-7500).

Educating the Architect: Fire and Life Safety

Thirty-three-page report (1975) prepared by the AIA task group on fire and life safety, documenting the need for better firesafety curricula in education, and a program to implement the proposed recommendations. Free.

Available through Codes and Standards Office (626-7456).

One Code: A Program for Building Regulatory Reform

43-page report (1975) prepared by the AIA task group on building regulation, detailing a mechanism for achieving building code uniformity in the U.S. Free.

Available through Codes and Standards Office (626-7456).

Prescriptive Standards: No Rx for Energy Conservation in Buildings (6-N816)

Folder (1976) promoting performance-oriented standards for energy conservation, rather than prescriptive standards. Free.

Available through Publications Fulfillment Office (626-7332).

For further information about codes and standards in general, contact the Codes and Standards Office, 626-7456.

Community Centers

We Have To Be Able To Do It Ourselves

16mm color film discussing community design centers—what they are, what they do and why they work, featuring Phila-

delphia, Cleveland, New Orleans and San Francisco. Free loan.

Available through Audiovisual Division, Library (626-7456).

Community Development

Community Design Center Technical Assistance

The director of minority resources and other specially selected experts assist CDCs with specific problems through on-site visits.

Contact Director, Minority Resources Office (626-7434).

Community Design Centers Profile

Annual directory listing CDCs, with information about each regarding organization, funding, staff, activities, affiliations, etc. Free.

Available through Director, Minority Resources Office (626-7434).

Community Development Block Grants: Opportunities for Shaping Urban Growth

17-page publication (revised 1978) that identifies for local government officials and concerned citizens provisions of Title I which provide opportunities for implementing AIA's principal urban growth policy recommendations. Free.

Available through State Component Affairs Office (626-7386).

Involving Architects in the Community Development Block Grant Programs:

A Strategy Guide For AIA Components

For component use, provides guidance in the CD block grant planning and application process to encourage local AIA involvement in the programs. Free.

Available through State Component Affairs Office (626-7386).

For further information about community development, contact the Minority Resources Office (626-7434).

Competitions

ASC/AIA Student Competitions

Several competitions are held each year. *Contact Association of Student Chapters/AIA, at AIA Headquarters (626-7472)*

Competitions Advisory Service

Information and assistance regarding architectural design competitions provided to sponsors, professional advisers, jurors and competitors in order to improve the planning and management of current and future design competitions.

Contact Design and Environment Programs Office (626-7363).

Design Competitions Archive

AIA library competitions archive is a re-

pository for the documentary material (excluding drawings) generated by architectural design competitions. Sponsors and/or professional advisers of recent competitions should send the archive copies of competition announcements, press releases, photographs of winning designs, publications, etc. Drawings should be donated to local libraries or archives. *Contact the Library (626-7493).*

Guidelines for Architectural Design Competitions (6-J332)

Thirteen-page document issued as a guide to conducting architectural design competitions. Free.

Available through Publications Fulfillment Office (626-7332) or Design and Environment Office (626-7363).

McDonald's Competition: The Most Innovative McDonald's of the Future

Catalog of the ASC/AIA McDonald's design competition, offering comments from jury members, photographs and descriptions of the winning entries, and other sample entries. \$4/\$6.

Contact Association of Student Chapter/AIA, at AIA Headquarters (626-7472).

For further information about competitions in general, contact Design and Environment Programs Office (626-7363).

Components, AIA

AIA Component Clearinghouse

Service providing components with information on operations and numerous programs, including associate members in chapter programs, homeowners' clinics, component speakers' bureaus, Women's Architectural Leagues, sources of nondues income for chapter programs and establishing a component foundation. Free.

Available through the Component Services Office (626-7377).

AIA Component Profile (4-N610)

Comprehensive survey report (December 1979) on the characteristics of AIA components and the programs and services they provide to their members and communities. Based on data collected from 208 AIA components from May to August 1979. \$7.

Available through Component Services Office (626-7377).

AIA Component Profile Supplement

Charts the programs and services provided by state and local components and includes a list of component budgets, publications, membership brochures and job descriptions available from the AIA component clearinghouse (January 1980). Available through *Component Services Office* (626-7377).

Architects at the Legislature: Lobbying for a Statute of Limitations

Case studies reflecting both successful and unsuccessful lobbying efforts by AIA components and related organizations in Missouri, Minnesota and Illinois.

Available through *State Component Affairs Office* (626-7386).

Calendar: National AIA Functions and Deadlines for Use of Component President

Annual calendar designed to aid component presidents: notices of meetings, deadlines, etc. Free.

Available through *Component Services Office* (626-7377).

Celebrating Excellence: Program Package 11 (6-N829)

A "how-to" guide that addresses AIA components interested in setting up successful awards programs. With documented examples from Florida Association/AIA, Houston Chapter/AIA and other components' efforts, this package provides basic information and guidelines for each step of the program. An insert of the AIA Board Guidelines for Component Awards Programs is included. Free to components.

Available through *Public Relations Department* (626-7460) or *Publications Fulfillment Office* (626-7332).

A Celebration of Architecture: 25 Ideas for Components

Slide show and script that briefly describe 25 ways for AIA components to focus the public's attention on the built environment. The show outlines projects used to implement AIA's 1979 Celebration of Architecture program—tours, exhibits, guidebooks, etc. An "idea-kit" for components looking for PR projects to undertake. Free loan to components.

Available through *Public Relations Department* (626-7460).

Component Assistance Teams (CATS)

Teams composed of AIA members, staff and/or component executives, formed on an ad hoc basis when requested by a component. Purpose is to advise on

internal (organizational) or external problems.

Contact *Component Affairs Office* (626-7378).

Component Charter Form

Application to be submitted by members requesting chapter status within AIA; to be used in the formation of any new chapter. Free.

Available through *Component Services Office* (626-7377).

Component Editors Critique Service

A program to help improve the skills of editors of component newsletters and magazines. Critiques by graphic and editorial consultants are available on request.

Contact *Public Relations Department* (626-7460).

Component Executives—Do We Need One? (6-N608)

Brochure designed for component leaders who may be considering employing a component executive. Describes what an executive does and how a skilled manager can help elected leaders make the organization a more successful professional association. Discusses budget considerations and staff alternatives. Prepared by the Council of Architectural Component Executives (CACE). Free. Maximum 10 copies per component.

Available through *Component Services Office* (626-7377).

Component PR Assistance/Counseling

A program that offers different kinds of PR information, program packages, counseling and other aids to help components solve individual PR problems.

Contact *Public Relations Department* (626-7459).

Component Presidents' Manual

Descriptive manual on yearly chapter operations, including planning, programming and budgeting techniques. Free. One per chapter.

Available through *Component Services Office* (626-7377).

Direct Government Affairs Assistance

Direct assistance to components in the form of on-site consultation and resource documents for those seeking to expand established government affairs activities or focus on individual issues. Consultation by component officers and executives and Institute staff.

Contact *State Component Affairs Office* (626-7385)

Disaster Assistance Programs: A Strategy Guide for AIA Components

Describes how components of AIA can organize and implement disaster relief programs at the state and local levels. Emphasizes long-term planning and how architects can work with state and other volunteer organizations (Jan. 1979).

Available through *State Component Affairs Office* (626-7386).

Effective Public Relations: A Guide for AIA Components (4-N805)

Annual loose-leaf "how to" handbook on PR planning, press relations, newsletters, speeches, television, etc. Free to chapter presidents, executives and PR chairmen; \$5 to others.

Available through *Publications Fulfillment Office* (626-7332).

Government Alert for Components

Bulletin published six times per year, containing brief, timely reports on government affairs developments at the state and local level. Free.

Available through *State Component Affairs Office* (626-7386).

Governmental Information Clearinghouse

A service to provide components with information on state and local issues of professional and public concern. Materials available include copies of legislation, administrative rules, governmental studies and reports, AIA documents and other background materials. Includes data on liability, energy, registration.

Contact *State Component Affairs Office* (626-7386).

Grassroots

Series of three regional meetings held in January of each year which bring component officers and executives together with national officers and staff. Purpose is to review and discuss national programs and policies, give component leaders an opportunity to provide input into the national planning process and provide a forum for the exchange of ideas among components. (Program will be held only one time during 1981, in Washington, D.C.)

Contact *Component Services Office* (626-7376).

Guidelines for Component Award Programs

This 12-point guideline developed by the committee on design was reviewed and shaped jointly by the committees of practice and design and component affairs. Free.

Available from *Public Relations Department* (626-7460).

Guidelines for Component Bylaws

Assistance with component bylaws. Contact *Component Affairs Office* (626-7378).

How to Organize an Effective Government Affairs Program

Forty-page guide for improving component government affairs programs. Includes information on the purpose and structure of such programs, the legislative process and state governmental contact systems. Free.

Available through State Component Affairs Office (626-7386).

How to Work Effectively with State Legislatures

Forty-four-page publication (1969) by the American Society of Association Executives, advising associations on establishment of a legislative program, lobbying, campaigning and evaluating a legislative session. Free.

Available through State Component Affairs Office (626-7386).

Involving Architects in the Community Development Block Grant Programs: A Strategy Guide for AIA Components

For component use, provides guidance in the CD block grant planning and application process to encourage local AIA involvement in the programs. Free.

Available through State Component Affairs Office (626-7386).

Membership Forms/H Series

The following forms are intended for components' use. Free.

H301 Application for Membership

H302 Application for Associate Membership

H303 Favorable Recommendation of Chapter on Application for Membership

H305 Recommendation of Chapter for Unfavorable Action on Application for Membership

H351 Application for Professional Affiliateship

H601 Application for Membership Emeritus

H713 Favorable Recommendation for Remission of Institute Dues

Available through Membership Records Division, Office of Assistant Secretary (626-7393).

Mini-Grassroots

Program of 45 minutes to one and a half hours, designed to aid components in programming. Gives overview of AIA services and benefits to members and augments local members with national staff. Can be combined with membership recruitment activities. Free.

Contact Component Services Office (626-7376).

Organizational Directory (4-P105)

Annual directory of AIA officers and committees, component officers and executives. Shows organizational structure of Institute. Includes a list of related architectural organizations. Free to component officers and executives. \$6 to AIA members only.

Component officers and executives contact the Component Services Office (626-7376). Members contact Publications Fulfillment Office (626-7332).

Original State and Local Government Programs Documents—Legislative Guidelines and Strategies

These documents may include model legislation, legislative guidelines, background information and strategies for component action on significant governmental issues.

Contact State Component Affairs Office (626-7386).

Public Relations Letter (PRL)

Bimonthly newsletter that gives case studies of component programs, national PR, announcements of program packages, "how-to" tips, etc. Especially useful for chapter PR chairmen. Index and 18 issues. Free.

Available through Public Relations Department (626-7460).

Sample Articles for Components

A collection of sample articles to help AIA components encourage newspaper editors to run regular columns on architecture in local papers. Each article discusses a different aspect of architecture of interest to the public. Free to components.

Available through Public Relations Department (626-7460).

Schedule: Regional and State Conventions and Expositions

Annual schedule of meetings to be held by components, including place, expected attendance and contacts. Free.

Available through Convention Office (626-7395).

State Energy Conservation Plans: Opportunities for AIA Components

Outlines options for AIA components' involvement in the Department of Energy's program financing supplemental state energy conservation plans and energy audits (1977).

Available through State Component Affairs Office (626-7386).

State/Local Government: Issues & Strategies (4-N508)

Reference notebook (1979) for AIA components and architects working on government affairs issues. Updated annually, it contains sections on major issues, strategies, case studies and space for com-

ponent materials. \$20 to AIA members only.

Available through Publication Fulfillment Office (626-7332).

Women's Architectural Leagues

Organized to promote and advance public awareness of architecture and to complement the activities of local AIA components. WAL has chapters throughout the country and holds a national meeting in conjunction with the annual AIA convention. Interested persons and components may obtain a roster of WAL chapters and information on local chapter activities.

Available from Component Services Office (626-7377).

You and Your Component Executive (6-N607)

Brochure written for component officers and directors, identifies major areas of responsibility of both component executives and components themselves with respect to their executives. Prepared by the Council of Architectural Component Executives (CACE). Free.

Available through Component Services Office (626-7376).

Computer Applications

CFMS—Computer Based Financial Service

Six-page brochure by the system operator, Harper & Shuman, Inc., describing the Institute's multifaceted computer based system for design professionals. Explains how CFMS provides detailed, understandable financial reports. Free.

Contact PSAE, a wholly owned corporation of AIA, at AIA Headquarters (626-7446).

Developing Computer-Based Systems for Building Codes

A report on an exploratory research effort funded by the National Science Foundation, conducted by AIA Research Corporation. This is a study of the implications of computer technology on building regulations. \$4.

Available through AIA Research Corporation, at AIA headquarters (626-7500).

For further information about computer applications in general, contact the Practice Office, 626-7457. Questions regarding MASTERSPEC should be directed to Production Systems for Architects and Engineers, Inc. (PSAE), at AIA Headquarters, 626-7446.

Construction Industry

All Weather Construction

Sixty-five color slides with tape cassette and script explaining techniques for cold weather masonry construction. Free loan to AIA members.

Available through Audiovisual Division, Library (626-7495).

Construction Bonds and Insurance Guide, 2nd edition (2-M163)

Loose-leaf reference book (1979) prepared by Bernard B. Rothschild, FAIA, containing information on bonds and insurance related to construction projects, with glossary of insurance terms and suggested check list. \$16/\$20.

Available through Publications Fulfillment Office (626-7332).

The Construction Industry (1-HBC2)

Chapter 2 (1969) of the Architect's Handbook of Professional Practice, this document includes information on the industry, the owner, the design professions, the constructors and related elements, special types of construction services, comprehensive architectural services and building organizations. \$60/\$90.

Available through Publications Fulfillment Office (626-7332).

Design and Construction Methods

(4-N410Q)

Prepared by the AIA committee on architecture for commerce and industry, this pamphlet provides a summary of the most prevalent approaches to getting a building project designed and constructed. Design/award/build, fast track and the design team approach are only three of the options available to the architect as an owner. Single copies are free; in bulk quantities the cost is \$7/100 copies.

Available through Publications Fulfillment Office (626-7332).

Glossary of Construction Industry Terms

(2-M101)

Eighteen-page publication (1970), including definitions of terms with special meaning or connotation in the construction industry. \$1/\$1.50.

Available through Publications Fulfillment Office (626-7332).

Construction Management

Construction Cost Analysis (1-HBC15)

Chapter 15 (1970) of the Architect's Handbook of Professional Practice, this

document covers considerations in cost analysis, statements of probable construction cost, project cost records, cost analysis methods, variables and aids. \$.60/\$.90.

Available through Publications Fulfillment Office (626-7332).

Design/Build/Bid (2-M199)

36-page report (1975) of the AIA design-build task force appointed in early 1973. Includes owner's guide. \$3/\$3.50.

Available through Publications Fulfillment Office (626-7332).

Design/Build/Bid: An Owner's Guide (6-N903)

Booklet (1975) intended to assist a potential client in the public sector in evaluation of the design-build-bid process. Free.

Available through Publications Fulfillment Office (626-7332).

Project Delivery Approaches: An AIA Guide (2-M702)

Thirty-page publication (1976) edited by David S. Haviland of the AIA project management systems task force. This guide is essentially a primer and is planned as the nucleus and framework for AIA development of a series of studies and guidelines for responsive and creative project delivery approaches. \$3.25/\$4.

Available through Publications Fulfillment Office (626-7332).

Value Engineering and Life Cycle Bibliography

Four-page selected and annotated bibliography (1975) prepared by the AIA committee on architecture for commerce and industry. Free.

Available through the Library (626-7493).

For further information about the use of construction management documents, contact the Documents Office, 626-7454.

Continuing Education

AIA/Construction Products

Manufacturers Council Programs

Programs dealing with production technology for architectural firms. Contact Professional Development Office (626-7355).

AIA Professional Development Catalog

List of all AIA-approved professional development programs dealing with such subjects as personal skills, marketing, practice management, design, production technology, codes and standards, environmental analysis, extended practice and public interest issues. Programs are developed by AIA, educational institutions, other professional organizations

and independent firms and individuals. \$9.95/\$11.95.

Available from Professional Development Office (626-7355).

Architectural Correspondence Programs

Long-distance courses that enable the architect, or a team of architects, to interact with a group of experts, aided by a specially programmed computer in New York. Printed materials are sent, and the architect then proceeds at his or her own pace, in contact with these specialists and the computer each step of the way.

Achieving Results with Words (4-T104) \$110

Conducting Successful Energy Audits (4-T108) \$125

Land Development Game Seminar (4-T102) \$85

Making Effective Presentations (4-T105) \$85

Managing a Professional Practice (4-T107) \$85

Marketing Architectural Services (4-T103) \$85

Successful Selling of Professional Services (4-T106) \$85

Order by title and number from Professional Development Office (626-7355).

Architectural Training Laboratories

One- or two-day programs focusing on specific topics of interest to architects. Each laboratory is conducted by a nationally recognized authority in the subject area. The programs are designed and produced by AIA for implementation by state, regional and local components.

The Architect and the Law

The Architect's Fee #1 (1981)

The Architect's Fee #2 (1981)

Financial Analysis of Building Projects

Financial Management for Profit and

Growth in Small Architectural Firms

Investment Strategies for Project Success

Profit Decisions: Project Success

Visual Communication in Architecture

Contact Professional Development Office (626-7355).

Cassette Library

Special subject cassettes are designed to give the architect a balanced survey of the subject as it applies to professional situations. AIA member/nonmember prices are given.

Building Evaluation (3-S212) \$9/\$10.

Current Techniques in Architectural Lighting (3-S223) \$13/\$14.50.

Designing Your Brochure as an Aid in Marketing Your Services (3-S224) \$9/\$10.

The Management of Time (3-S216) \$9/\$10.

The Planned Approach to Architectural Practice (3-S229) \$9/\$10.

Selling Architectural Services I (3-S207) \$9/\$10.

Selling Architectural Services II (3-S218) \$9/\$10.

Setting Up an Architectural Firm (3-S223) \$13/\$14.50.

Available through Publications Fulfillment Office (626-7332).

Intern-Architect Development Program (IDP)

Counseling Materials: The AIA department of education and professional development and the NCARB, partners in the intern-architect development program, will use the counseling network to provide information packages to local professional advisers who will be in direct contact with intern-architects. Information will focus on broad career options, immediate job opportunities, economic outlook, the future of the profession and AIA programs and activities. Free descriptive circulars are available from NCARB (659-3996).

Local Professional Seminars

Programs produced, sponsored and presented by local components of AIA or jointly with another program producer. They are directed to specific local audience needs and draw upon resources of the area.

Architecture and Law

Architectural Office Practice

Building Code Seminar

Doors & Hardware—Access Security

Energy/Daylight Design

Practice Management

Specification Seminar

Specification Workshop on the Technical Section

Wood—the Modern Alternative

Contact Professional Development Office (626-7355).

Minnesota Compendium of Professional Development Programs

Collection includes curriculum outlines of 12 recent component continuing education programs: architecture and the law—conflicts and issues, acoustical design, summer design series, marketing design

services, an architectural study tour of Toronto, projects cost benefit analysis, energy maxi-audit procedures and others. \$5.

Available through Minnesota Society AIA, 314 Clifton Ave., Minneapolis, Minn. 55403, (612) 874-8771.

National Professional Seminars

Produced, sponsored and presented by AIA or by an approved national program producer.

Acoustics in Buildings

AIA Energy Course

Architect Woodwork Seminar

Architectural Acoustics

Barrier-Free Design

Barrier-Free Design: Access for All

Basic Techniques of Systems Drafting #1

Basic Techniques of Systems Drafting #2

Built-Up Roofing—Design/Construction

Computerized Building Energy Analysis

Condominium Conversion

A Day at Taliesin West: A Forward Look

Design and Analysis/Subterranean

Developing Subsidized Housing

Developing the Competitive Edge:

Analyzing and Marketing Your Practice

The Development of Real Property

Effective Communication: Improving the Bottom Line

Energy-Conscious Design: Thermal

Inertia in Architectural Walls

Environmental Encounter

Financial Management of Design and Planning Firms

Glass and Glazing

How to Plan, Site and Merchandise the Smaller House

Human Behavior and Housing Design

HVAC: Heat Recovery and Storage Systems

HVAC: Variable Air Volume Systems

Inside Architecture '80

Insulation Products/Systems #1

Insulation Products/Systems #2

Insulation Products/Systems #3

Japanese Gardens

Land Use Law for Planners/Developers

Landscape Resource Analysis

Management of Design and Planning

Marketing/Communications for the Design Professional

MASTERSPEC

Metal Curtain Walls—Commercial/Industrial

The Natural Alternative: Earth-Sheltered Design and Construction

Office Practice: The Agony and the Ecstasy

Participatory Learning in Museums

Passive Solar Energy Conservation

Passive Studio—Design for Heating, Cooling and Daylighting

PLEC Systems

Plumbing Products/Systems

Principles of Life Cycle Cost Benefit Analysis

Problem Solving with CPM

Professional Liability

Project Organization/Scheduling/Control for Architects

Public Art: Delight or Dilemma

Realities of Historic Preservation

Resourceful Planning for Museums

Roofing Construction Techniques

Simplified Life Cycle Cost Benefit Analysis

Solar Energy Building Design

Solar Energy Savings

Steel in Design

Structural Glued Laminated Timber

Terrain Analysis

Tools for Passive Solar Energy

Urban Design/Strategic Policy

Value Engineering Training Workshop

Visual Resources Collections

Development, Administration and Management

Contact Professional Development Office (626-7355).

Programs Approved By Professional Development Network

Programs planned to give architects and other professionals a basic technical understanding in pertinent areas. Three to four hours each. Continuing Education Units (CEUs) are awarded to participants upon completion.

For information on content, instructors and locations, contact Professional Development Office (626-7355).

Regional Professional Seminars

Presented by expert in the particular subject or a team. The typical format is a presentation of material followed by group discussion and practical exercises. Developed by AIA or by AIA-approved program producers and presented for statewide or regional audiences.

Adding Art & Humanities to Your Campus

Architectural Acoustics

Architecture and Law

Brick Masonry Design/Construction

Computer Applications/Architectural
Computer Based Systems
Conscious Energy Use in Buildings
Conserving Energy with Lighting
Cost Estimating for Architects
Design for Profit
Effective Time Management
Energy Analysis Short Course
Energy Conservation Construction
Going Under to Stay on Top: Housing
How to Cut Production Costs
Marketing Architectural/Design Services
New Energy Code: How to Comply
New York State Conservation
Construction Code
New York State Energy Code
Operating Passive Energy Tools
Promoting Professional Services
Quality Control in Design Construction:
Avoiding Big Errors
Summer Design Series
Technical Assistance Audit
Uniform Building Code
Workshop on Acoustics on the Technical
Section
*Contact Professional Development Office
(626-7355).*
SupEdGuides (2-N206)
The AIA supplementary education pro-
gram guides provide new learning oppor-
tunities and enlarge upon the normal on-
the-job learning experiences. Each guide
is \$2.80 to AIA members, \$3.50 for
nonmembers. Complete set (excluding
C1, C2 and A1) \$67 to AIA members,
\$84 to nonmembers. SupEdGuide
catalog \$5. (4-N206-0)
Architects' Roles (A1)
Budgeting Project Costs (E4)
Changes in the Work (F7)
Claims and Disputes During Construction
(F9)
Client Relations During Design (E2)
Construction Contract Documents (F2)
Construction Progress Payments (F8)
Controlling Project Time (E5)
Delivery Approach (D5)
Design Documentation (E7)
External Arrangements (B6)
Financial Aspects of Practice (B3)
Financing (D4)
Information Requirements in Design (E6)
Insurance Aspects of Practice (B5)
Internal Office Arrangements (B2)
Legal and Ethical Considerations (B4)
Marketing Methods (C2)
Negotiating the Owner-Architect
Agreement (E1)

Organizing for Getting Business (C1)
Program (D2)
Progress of the Work (F4)
Project Initiation (D1)
Proposal and Award (F1)
Selecting the Team Members (E3)
Site (D3)
Site Visits (F5)
Submittals and Approvals (F6)
Types of Practice (B1)
*Available through Publications Fulfillment
Office (626-7332).*

Contract Information

The AIA Handbook (1-HBC1)
Chapter 1 (1973) of the Architect's
Handbook of Professional Practice, this
document includes general information on
the Handbook, including the preface,
table of contents, general index and
information on chapters. \$.60/\$.90.
*Available through Publications Fulfillment
Office (626-7332).*

**Architect's Handbook of Professional
Practice (1-M104)**
This two-volume set in ring binders
includes samples of all A, B, C, D, E and
G series documents, plus 18 chapters and
a glossary of construction industry terms.
\$23.50/\$35 (1-M104). Contents only (no
binders), \$16.75/\$25 (1-M104A). Two
binders (no contents), \$6.75/\$10.
(1-M104B). Individual chapters of the
handbook are listed under **AIA Docu-
ments**, and described under the subjects
they cover.
*Available through Publications Fulfillment
Office (626-7332).*

**Architect's Handbook of Professional
Practice—Supplement Service (4-Z100)**
Subscriptions to the Supplement Service
bring the latest editions of the documents
contained in the handbook directly to
subscribers. \$12.
*Available through Publications Fulfillment
Office (626-7332).*

**Construction Contract Administration
(1-HBC18)**
Chapter 18 (1973) of the Architect's
Handbook of Professional Practice, this
document covers the division of responsi-
bility, the project representative, contract
documents, construction documents,
project inception, administration, termi-
nation, post completion, notes on certain
projects and AIA contract administration
documents. \$1.20/\$1.80.
*Available through Publications Fulfillment
Office (626-7332).*

**General Conditions of the Contract for
Construction (1-HBC13)**
Chapter 13 (1970) of the Architect's
Handbook of Professional Practice, this
document outlines the history of the AIA
General Conditions, its use, comments on
A201, A201/SC federal edition, A107
and supplementary conditions. \$1.20/
\$1.80.
*Available through Publications Fulfillment
Office (626-7332).*

**Owner-Contractor and Contractor-
Subcontractor Agreements (1-HBC17)**
Chapter 17 (1973) of the Architect's
Handbook of Professional Practice, this
document covers stipulated sum agree-
ments, short form agreements, cost plus
fee agreements, execution of agreements,
letters of intent, service documents, etc.
\$1.20/\$1.80.
*Available through Publications Fulfillment
Office (626-7332).*

Selection of Contractors (1-HBC16)
Chapter 16 (1971) of the Architect's
Handbook of Professional Practice, this
document covers objectives and pro-
cedures, bidding documents, methods of
awarding contracts, the contract system,
types of contracts, examination of
prequalification of bidders, preparation
and receipt of bids, awarding and
executing the contracts. \$.60/\$.90.
*Available through Publications Fulfillment
Office (626-7332).*

*For further information about contract
documents in general, including their use
and interpretation, contact the Documents
Office, 626-7454. Orders for individual
documents (listed in this guide under
AIA Documents) should be directed to
the Publications Fulfillment Office,
626-7332.*

Contracts and Documents

Documents may be obtained from the AIA Publications Fulfillment Office, 1735 New York Ave. N.W., Washington, D.C. 20006, or from your authorized local distributor for AIA contracts and forms. **All document orders should be directed to your local distributor if you reside in one of the following states:** Alabama, Arizona, California, Colorado, Connecticut, Florida, Georgia, Hawaii, Idaho, Illinois, Indiana, Iowa, Kansas, Kentucky, Louisiana, Massachusetts, Michigan, Minnesota, Mississippi, Montana, Nebraska, New Jersey, New Mexico, New York, North Carolina, Ohio, Oklahoma, Oregon, Pennsylvania, Rhode Island, South Dakota, Tennessee, Texas, Utah, Washington and Wisconsin.

For faster service, you are encouraged to contact the local distributor in your area when ordering AIA documents. A complete list of distributors is on page 134.

Because AIA documents in the A-G Series and all chapters from the Architect's Handbook of Professional Practice are revised regularly, some may have been superseded by new editions. Editions listed are the latest available.

The following instructions apply only when ordering from AIA in Washington, D.C. Documents may be ordered by letter furnishing the following information:

1. Your name, correct mailing address and component/chapter affiliation (if applicable).
2. Quantity, document number and price of each document you wish to order.
3. Check or money order payments **MUST** accompany all orders totalling \$20 or less in costs **AND** all nonmember orders.
4. District of Columbia residents add 5 percent sales tax to cost of documents purchased.
5. For first class, airmail, special delivery, air express handling, add 20 percent to total dollar amount of items ordered.
6. All orders from Canada, the West Indies and Latin America must be accompanied by check or money order payable in U.S. dollars. Payment must include postage in the amount of 20 percent added to dollar amount of documents ordered.

All orders from countries other than U.S., Canada, the West Indies and Latin America should be directed to: RIBA Publications Limited, 66 Portland Place, London, W1N 4AD, England. PUBS has been appointed agent and distributor for publications and visual aids produced by AIA in the following countries and territories: United Kingdom and Northern Ireland, Republic of Ireland, Europe, Republic of South Africa, the Middle East and member countries of the British Commonwealth. Foreign architects electing to become AIA correspondent members may order documents from either AIA in Washington, D.C., or PUBS in London.

A SERIES/Owner-Contractor Documents

		Non-Member Price	Member Price
A101	Owner-Contractor Agreement Form—Stipulated Sum (6/77) with instruction sheet wrapped	\$.70	\$.50
A101 /CM	Owner-Contractor Agreement Form—Stipulated Sum—Construction Management Edition (6/80) with instruction sheet wrapped70	.50
A107	Short Form for Small Construction Contracts—Stipulated Sum (4/78) with instruction sheet wrapped70	.50

		Non-Member Price	Member Price
A111	Owner-Contractor Agreement Form—Cost Plus Fee (4/78) with instruction sheet wrapped70	.50
A117	Abbreviated Owner-Contractor Agreement Form—Cost Plus (3/79) with instruction sheet wrapped70	.50
A171	Owner-Interiors Contractor Agreement Form (3/79) with instruction sheet wrapped70	.50
A177	Abbreviated Owner-Contractor Agreement for Furniture, Furnishings and Equipment (5/80) with instruction sheet wrapped70	.50
A201	General Conditions of the Contract for Construction (8/76)	1.75	1.20
A201 /CM	General Conditions of the Contract for Construction—Construction Management Edition (6/80)	1.75	1.20
A201 /SC	General Conditions of the Contract for Construction and Federal Supplementary Conditions of the Contract for Construction (8/77)	2.10	1.40
A271	General Conditions of the Contract for Furniture, Furnishings and Equipment (12/77)	1.50	1.00
A271A	Instruction Sheet	N/C	N/C
A305	Contractor's Qualification Statement (3/79)70	.50
A310	Bid Bond (2/70)25	.17
A311	Performance Bond and Labor and Material Payment Bond (2/70) ..	.35	.23
A311 /CM	Performance Bond and Labor and Material Payment Bond—Construction Management Edition (6/80)35	.23
A331	Guaranty for Bituminous Roofing (1/66)30	.20
A401	Contractor-Subcontractor Agreement Form (4/78)45	.30
A501	Recommended Guide for Bidding Procedures and Contract Awards (11/69)	1.80	1.20
A511	Guide for Supplementary Conditions (7/77)	1.50	1.00
A521	Uniform Location Subject Matter (1977)	2.00	1.00
A701	Instructions to Bidders (5/78) with instruction sheet wrapped70	.50
A771	Instructions to Interiors Bidders (5/80) with instruction sheet wrapped70	.50

B SERIES/Owner-Architect Documents

B141	Standard Form of Agreement Between Owner and Architect (7/77) with instruction sheet wrapped70	.50
B141 /CM	Standard Form of Agreement Between Owner and Architect—Construction Management Edition (6/80) with instruction sheet wrapped70	.50

		Non-Member Price	Member Price			Non-Member Price	Member Price
B151	Abbreviated Owner-Architect Agreement Form (6/78)60	.40	F102	Cash Journal—1949	2.40	1.60
B161	Standard Form of Agreement Between Owner and Architect for Designated Services (11/77)60	.40	F103	Cash Journal—1949	2.40	1.60
B161A	Instruction Sheet	N/C	N/C	F104	Cash Journal—1953	2.40	1.60
B162	Scope of Designated Services (11/77) with instruction sheet wrapped	3.00	2.00	F105	Cash Journal—1949	2.40	1.60
B171	Standard Form of Agreement for Interior Design Services (11/77)60	.40	F106	Cash Journal—1949	2.40	1.60
B171A	Instruction Sheet	N/C	N/C	F107	Journal Form—1949	2.40	1.60
B177	Abbreviated Interior Design Services Agreement (5/80) with instruction sheet wrapped70	.50	F201	Payroll Journal—1953	2.40	1.60
B181	Owner-Architect Agreement for Housing Services (6/78) with instruction sheet wrapped60	.40	F202	Payroll Journal—1949	2.40	1.60
B352	Duties, Responsibilities, and Limitations of Authority of the Architect's Project Representative (5/79)35	.23	F203	Payroll Journal—1949	2.40	1.60
B431	Architect's Qualification Statement (12/79)35	.23	F301	Ledger Account Form—1949	2.40	1.60
B551	Withdrawn			F401	Job Expense Record Form—1953 ..	2.40	1.60
B727	Standard Form of Agreement Between Owner and Architect for Special Services (6/79) with instruction sheet wrapped70	.50	F403	Fixed Assets Record—1949	2.40	1.60
B801	Standard Form of Agreement Between Owner and Construction Manager (6/80) with instruction sheet wrapped70	.50	F404	Note and Investment Record—1949 ..	2.40	1.60
C SERIES/Architect-Consultant Documents				50 SHEETS PER UNIT			
C141	Standard Form of Agreement Between Architect and Engineer (6/79) with instructions wrapped ..	.70	.50	F501	Trial Balance—1953	3.60	2.40
C161	Standard Form of Agreement Between Architect and Consultant (6/79) with instructions wrapped ..	.70	.50	F502	Balance Sheet—1953	3.60	2.40
C431	Standard Form of Agreement Between Architect and Consultant for other than Normal Engineering Services (3/72)60	.40	F503	Profit and Loss Statement—1949 ...	3.60	2.40
C801	Joint Venture Agreement (6/79) with instructions wrapped70	.50	F504	Indirect Expense Factor—1953	3.60	2.40
D SERIES/Architect-Industry Documents				F601	Time Record Sheet—1971	4.80	3.20
D101	Architectural Area and Volume of Buildings (1/80)30	.20	F603	Expense Voucher Nonpersonnel—1953	2.10	1.40
D200	Project Checklist (5/73)	1.80	1.20	F605	Expense Record—1953	2.10	1.40
E SERIES/Architect-Producer Documents				F701	Billing Extract—1972	4.50	3.00
E101	Technical Literature for the Construction Industry (7/72)60	.40	F703	Aged Accounts Receivable—1972 ..	4.50	3.00
F SERIES/Architect's Accounting Forms—Manual System				F712	Project Payroll Cost Worksheet—1972	4.50	3.00
F101	Cash Journal—1949	2.40	1.60	F714	Detail of Expenses—1972	4.50	3.00
				F716	Time Distribution Summary—1972 ..	4.50	3.00
				F721	Project Estimating and Budget Worksheet—1972	4.50	3.00
				F723	Project Progress Report—1972	4.50	3.00
				F725	Project Summary Report—1972	4.50	3.00
				F SERIES/Compensation Guidelines Forms and Worksheets			
				F800	Complete Set of 2 Each of 24 Forms Needed—F810 thru F860 (1978) ..	4.80	3.20
				25 SHEETS PER UNIT			
				F810	Scope of Designated Service Worksheet (unphased)	2.40	1.60
				F820	Phase Compensation Worksheet (unphased)	2.40	1.60
				F850	Project Time and Payment Schedule ..	2.40	1.60
				F SERIES/Standardized Accounting For Architects Forms			
				25 SHEETS PER UNIT			
				F1001	Cash Receipts Journal (1978)	2.40	1.60
				F1002	Cash Disbursements Journal (1978) ..	2.40	1.60
				F1004	Trial Balance (1978)	2.40	1.60
				F1006	Balance Sheet and Income and Expense Statement (1978)	2.40	1.60
				F2002	Fixed Assets Record (1978)	2.40	1.60
				F2004	Notes and Investment Record (1978) ..	2.40	1.60
				F3003	Payroll Journal (1978)	2.40	1.60
				F3005	Staff Payroll Record (1978)	2.40	1.60
				F4001	Project Time Distribution (1978)	2.40	1.60
				F4003	Project Expense Record (1978)	2.40	1.60
				F5001	Billing Extract (1978)	2.40	1.60
				F5003	Aged Accounts Receivable (1978) ..	2.40	1.60
				F6001	Ledger Account (1978)	2.40	1.60
				F6002	Journal (1978)	2.40	1.60

		Non-Member Price	Member Price
F6003	Accounting Worksheet (1978)	2.40	1.60
F6004	Accounting Worksheet (1978)	2.40	1.60
	50 SHEETS PER UNIT		
F2001	Expense Voucher (1978)	4.50	3.00
F3001	Time Record (1978)	4.50	3.00
F3002	Staff Expense Record (1978)	4.50	3.00
F5002	Invoice for Architectural Services (1978)	4.50	3.00
G SERIES/Architect's Office and Project Forms			
	25 SHEETS PER UNIT		
G601	Land Survey Requisition (6/79) with instructions	5.00	3.35
G602	Soil Investigation and Engineering Services Agreement (6/79) with instructions	5.00	3.35
G610	Owner's Instructions for Bonds and Insurance (11/78)	4.50	3.00
	50 SHEETS PER UNIT		
G604	Change Authorization for Professional Services (3/79) with instructions ..	5.00	3.35
G701	Change Order (4/78)	4.50	3.00
G701	Change Order—Construction /CM Management Edition (6/80)	5.00	3.35
G702	Application and Certificate for Payment (4/78)	4.80	3.20
G703	Continuation Sheet for G702 (4/78) ..	4.80	3.20
G704	Certificate of Substantial Completion (4/78)	4.50	3.00
G705	Certificate of Insurance (11/78)	4.50	3.00
G706	Contractor's Affidavit of Payment of Debts and Claims (4/70)	4.50	3.00
G706A	Contractor's Affidavit of Release of Liens (4/70)	4.50	3.00
G707	Consent of Surety to Final Payment (4/70)	4.50	3.00
G707A	Consent of Surety to Reduction in or Partial Releases of Retainage (6/71)	4.50	3.00
G709	Proposal Request (4/70)	4.50	3.00
G710	Architect's Supplemental Instructions (3/79) with instructions	5.00	3.35
G711	Architect's Field Report (10/72)	4.50	3.00
G712	Shop Drawing and Sample Record (10/72)	4.50	3.00
G713	Construction Change Authorization (3/79) with instructions	5.00	3.35
G722	Project Application and Project Certificate for Payment (6/80) with instructions	5.00	3.35
G723	Project Application Summary (6/80) with instructions	5.00	3.35
G801	Application for Employment (6/75) ..	4.50	3.00

		Non-Member Price	Member Price
G804	Register of Bid Documents (4/70) ..	4.50	3.00
G805	List of Subcontractors (4/70)	4.50	3.00
G807	Project Directory (4/70)	4.50	3.00
G809	Project Data (4/70)	4.50	3.00
G810	Transmittal Letter (4/70)	4.50	3.00
G811	Employment Record (11/73)	4.50	3.00
G813	Temporary Placement (1/74)	4.50	3.00

Architect's Handbook of Professional Practice—Chapters

HBC 1	The AIA Handbook—197390	.60
HBC 2	The Construction Industry—1969 ..	.90	.60
HBC 3	AIA and Related Organizations—1972	1.80	1.20
HBC 4	Careers in Architecture—1972	1.80	1.20
HBC 6	The Architect's Office—1971	1.80	1.20
HBC 7	Insurance and Bonds of Suretyship—1969	1.80	1.20
HBC 10	Interprofessional Agreements—1975 ..	.90	.60
HBC 11	Project Procedures—1969	1.80	1.20
HBC 12	Construction Documents—Drawings—197090	.60
HBC 13	General Conditions of the Contract for Construction—1977	1.80	1.20
HBC 14	Construction Documents—Specifications—1972	1.80	1.20
HBC 15	Construction Cost Analysis—1970 ..	.90	.60
HBC 16	Selection of Contractors—197190	.60
HBC 17	Owner-Contractor and Contractor-Sub-contractor Agreements—1973 ..	1.80	1.20
HBC 18	Construction Contract Administration—1973	1.80	1.20
HBC 19	Legal Concerns—1969	1.80	1.20
HBC 21	The Architect as Preservationist—197190	.60
HBC B-8	Marketing Architectural Services—1980	2.25	1.50

Architect's Handbook of Professional Practice

M104	Architect's Handbook of Professional Practice (Set of 2 Volumes)	35.00	23.50
M104A	Architect's Handbook/ <i>Contents Only</i>	25.00	16.75
M104B	Architect's Handbook/ <i>Two Binders Only</i>	10.00	6.75

Miscellaneous

Z100	Handbook Supplement Service (1980) keeps M104 up-to-date	12.00	12.00
2M101	Glossary of Construction Industry Terms (1970)	1.50	1.00

For further information about interpretation of AIA documents, contact the Documents Office, 626-7440.

Education

Accredited Programs in Architecture

Annual list prepared by the National Architectural Accrediting Board (NAAB), containing those schools which offer accredited first professional degree programs, with addresses, phone numbers and names of deans. Free.

Available through *National Architectural Accrediting Board, at AIA Headquarters (833-1180)*.

ACSA News

Newsletter issued five times during the academic year, containing news about architectural schools. Available only by membership. Price: \$14 for students; \$23 for all others. Membership includes "Journal of Architectural Education." Available through *the Association of Collegiate Schools of Architecture, at AIA Headquarters (785-2324)*.

AIA Scholarship Announcement

Annual poster outlining program descriptions, eligibility criteria and application procedures for five AIA scholarship programs. Free.

Available through *Education Office (626-7349)*.

Architectural Career Awareness Package

(3-M401)

Eighty color slides with script for use by high school counselors or architects lecturing young groups of prospective architects. Includes "Architecture in Community and Junior Colleges," "Architecture Schools in North America" and assorted pamphlets. \$30, nonmembers; \$27, members.

Available through *Association of Student Chapters/AIA at AIA Headquarters (626-7472)*, or *Publications Fulfillment Office (626-7332)*.

Architectural Schools in North America

(3-M124)

Guide (1979) to all professional architecture programs in U.S. and Canada. Complete information on faculty, price, program, entrance requirements, etc. Includes introductory essays on architectural education, directory of foreign schools, joint degree programs and other information. \$8.25/\$8.95.

Available through *Association of Collegiate Schools of Architecture, at AIA (783-2388)* or *Publications Fulfillment Office (626-7332)*.

Architectural Secretaries Association

Organized to promote and advance the professional and educational standards of architectural secretaries and contribute to

the improvement of administrative procedures in architectural offices, ASA has chapters, locally sponsored by AIA chapters, all across the country.

Contact *Betsi Fassett, ASA/AIA Liaison (626-7387)* or *AIA chapter nearest you*.

Architecture Internship/Associate Membership

Cassette and slides looking into the experiences of architectural interns, with discussion of internship opportunities and associate membership in AIA. 10 minutes. Free loan to AIA members/components. Available through *Professional Development Office (626-7353)*.

ASC/AIA News

Monthly newsletter of the Association of Student Chapters/AIA with news items of interest to architectural students. Free to ASC/AIA members and CRIT/ASJ subscribers.

Available through *Association of Student Chapters/AIA, at AIA Headquarters (626-7472)*.

ASC/AIA Student Forum

Annual convention held over the Thanksgiving holidays which brings together architectural students from around the country. Forum '80 will be held in Philadelphia.

Contact *Association of Student Chapters/AIA, at AIA Headquarters (626-7472)*.

Counseling for Architectural Careers

Students desiring basic architectural career information are counseled by the education and professional development department staff. Counseling may be in person or by letter.

Contact *Education Office (626-7349)*.

CRIT—The Architectural Student Journal

Biannual magazine published by the Association of Student Chapters/AIA. Includes articles on architecture, architectural education and alternative careers in architecture. Free to ASC/AIA members. Two-year subscription is \$4.

Available through *Association of Student Chapters/AIA, at AIA Headquarters (626-7472)*.

Design Disciplines: An Overview of Office Practice

A series of seminars produced and sponsored by the Architectural Secretaries Association to introduce the new architectural secretary and/or recent architectural graduate to the administrative functions of an architectural practice.

Contact *Betsi Fassett, AIA/ASA Liaison (626-7387)*.

How to Conduct Environmental Education Workshops for Teachers and Architects (4-N205)

116-page guidebook documents and evaluates five workshops held to help train architects to function as resource people

for built environmental education. \$2.

Available through *Publications Fulfillment Office (626-7332)*.

Intern-Architect Development Program (IDP)

Cassette and slides of an in-depth review of IDP concepts, participation and operation, including the AIA supplementary education program and advisory system. 20 minutes. Free loan to AIA members/components.

Available through *Professional Development Office (626-7353)*.

Journal of Architectural Education

Quarterly (during academic year) journal of the Association of Collegiate Schools of Architecture (ASCA). Single issue \$4; free to ACSA members; \$12 per year to all others.

Available through *Association of Collegiate Schools of Architecture, at AIA Headquarters (785-2324)*.

Legal Study Program

Selected architect/law students may receive academic credit for a part-time work-study program concerned with legal matters and contract documents.

Contact *Documents Office (626-7454)*.

Life Experiences in Environmental Design (4-M127)

Publication (1975) containing interviews with students and recent graduates about their aspirations, travails, satisfactions, etc. Published by Association of Collegiate Schools of Architecture. 267 pages. \$4.

Available through *Publications Fulfillment Office (626-7332)*.

Proceedings of ACSA Annual Meeting

Yearly publication of papers from annual meeting workshops, exploring a wide range of topics by architectural faculty from U.S., Canada and abroad. Focus of 1980 proceedings: The Linguistic Analogy in Architecture. Paper, \$17.50; cloth, \$25.

Available through *Association of Collegiate Schools of Architecture, at AIA (785-2324)*.

A Program for Architectural Technicians' Training

Eighteen-page publication (1968) prepared by the AIA educational task force for architectural technicians' training, which makes recommendations for the establishment and improving of programs for architectural technicians. Free.

Available through *Education Office (626-7349)*.

Ed

Reynolds Aluminum Prize for Architectural Students

Brochure (1976) describing the annual award program open to students who have completed two years of architectural school. Sponsored by Reynolds Metals Co. and administered by AIA. Contains eligibility requirements, submission procedures, entry dates, etc., and a tear-off entry slip. Free.

Available through Awards Division, Office of Assistant Secretary (626-7390).

Student Competitions

Several competitions held throughout the year.

For current information contact the Association of Student Chapters/AIA, at AIA Headquarters (626-7472).

Summer Legal Intern

An architect/law student is selected each year to spend the summer working at AIA headquarters on contract documents and legal concerns.

Contact Documents Office (626-7454).

For further information about education of architects in general, contact the Education and Professional Development Office, 626-7347. Questions regarding careers and scholarship opportunities should be directed to the Education Office, 626-7349. Contact the Association of Student Chapters/AIA, 626-7472, and the Association of Collegiate Schools of Architecture, 785-2324 (both of which are located at AIA Headquarters) for information about their respective organizations.

Educational Facilities

A Child Went Forth

Color film (28 minutes, 16mm) focusing on the debilitating effects of the inner-city school on children, and providing a contrast with new innovative projects for school architecture. Free loan.

Available through Audiovisual Division, Library (626-7495).

For further information about educational facility planning, contact the Professional Interest Programs Office, 626-7366.

Energy

Basics of Solar Heating and Hot Water Systems (3-M262)

This 48-page publication (1977) from AIA Research Corporation discusses passive and active systems that can be used

in residential heating and domestic hot water systems. Introduces systems design considerations, from collector components and placement, to storage and heat exchangers, to distribution. Includes visual "state-of-the-art" view of solar energy systems in housing. \$4.50/\$5.

Available through Publications Fulfillment Office (626-7332).

Developing an Energy Performance Work Plan for Arizona Buildings, edited by Hugh Knoell, AIA

Report of \$52,000-grant program on developing performance-based criteria for energy conservation in buildings. All items postpaid.

Synthesis, Phase 1 \$7

Appendix A: Climate Charts \$7

Appendix B: Evaluation

Procedures \$7

Appendix C: Implementation

Issues \$7

Available from Arizona Architects Foundation, Inc., 1121 N. Second St., Phoenix, Ariz. 85004.

Energy and the Built Environment: A Gap in Current Strategies (6-N901)

Publication (1974) prepared by Leo A. Daly, FAIA, and the AIA task force on energy conservation, which shows how sustained efforts to achieve energy efficiency in the built environment can contribute toward solving the energy crisis, and proposes specific programs to bring this about. 18 pages; free.

Available through Publications Fulfillment Office (626-7332).

Energy and the Built Environment: A Gap in Current Strategies—A Nation of Energy Efficient Buildings by 1990 (6-N901; 6-N905)

Two major study reports on energy efficiency. Good reading for background in preparation for speaking, slide show presentation, basis for articles, etc. Free.

Available through Director of Energy Programs (626-7448).

Energy Audits (4-Z203)

Supplement 79-2, August 1979, for the AIA **Energy Notebook** introduces the concepts, procedures and techniques of effective energy auditing. Energy auditing is a means of identifying energy waste and opportunities for energy conservation in existing buildings. This publication should be studied in conjunction with other available resources such as **Energy**

Planning for Buildings (4-M270), also published by AIA. \$9.

Available through Publications Fulfillment Office (626-7332).

Energy Conservation in Building Design (4-M212)

Prepared by the AIA Research Corporation, it describes opportunities for con-

serving energy through building design. It is the product of a national energy policy study financed by the Ford Foundation to investigate various aspects of the technological and social impacts of energy supply and consumption. Soft cover, 156 pages, \$5.

Available through Publications Fulfillment Office (626-7332).

Energy Notebook (5-Z200N)

Developed and constantly updated by AIA, the **Energy Notebook** is a comprehensive information service. The set of two loose-leaf binders includes: well-documented case studies, reference guides, design approaches, a bibliography, article reprints, latest codes and regulations information. Subscribers receive quarterly "update packets" of new information for various sections of the manual. Current developments in standards, technical information, publications, seminars and workshops, and research projects are included in the "Energy Newsletter" sent 10 times during the year. 12-month service \$120 nonmember; \$90 AIA member. Renewal for 1979 edition (5-Z200R) \$60/\$90.

Available through Publications Fulfillment Office (626-7332).

Energy Planning for Buildings (4-M720)

Presents a proven process that design professionals can use (or adapt) to study the current energy performance of a building, uncover opportunities for energy-conscious improvements, evaluate those opportunities and see that they are carried out to the building owner's best benefit (1979). Describes in detail a manual technique for calculating energy usage and shows in a sample problem how that technique can be applied. Also provides a basis for understanding computer-aided energy estimating techniques. \$40/\$44.

Available through Publications Fulfillment Office (626-7332).

Hold on to Your Heat (and Keep Your Cool) (6-N906)

Pamphlet (1976) intended as a homeowner's guide to energy conservation. Describes how to take advantage of site, envelope, floor plan, windows, insulation, etc., to conserve energy. Includes bibliography. Free.

Available through Publications Fulfillment Office (626-7332).

A Nation of Energy Efficient Buildings by 1990 (6-N905)

Publication (1975) prepared by Leo A. Daly, FAIA, and the AIA energy steering committee, outlining a national program to achieve the potentials of energy efficient buildings in an economical and adminis-

tratively feasible manner. 20 pages, free. Available through Publications Fulfillment Office (626-7332).

New Design Concepts for Energy Conserving Buildings (3-M263)

This 124-page book (1977) describes 115 innovative approaches to designing energy-efficient buildings. From an AIA Research Corporation-sponsored energy-conscious design student competition, held in 1976. Twelve entries of distinction are featured in detail, using the students' drawings and diagrams. Text includes student interviews and jurors' comments. Contains bibliography and design concept index keyed to drawings. \$9/\$9.95.

Available through Publications Fulfillment Office (626-7332).

Passive Solar Design (4-N833)

Set of 80 slides and script (1980) illustrating passive solar design principles and their applications through diagrams and representational building samples. Regional and climatic considerations are evident in the examples used. Intended for a nontechnical audience. \$22 prepaid. After Oct. 1, 1980, available through Public Relations Department (626-7460) or Publications Fulfillment Office (626-7332)

A Plan for Total Energy Efficiency in Buildings (6-N907)

Report (1975) directed toward government policy makers, which discusses approaches to develop performance-based energy budgets and economic incentives for maximum energy efficiency. 25 pages; free.

Available through Publications Fulfillment Office (626-7332).

Prescriptive Standards: No Rx for Energy Conservation in Buildings (6-N816)

Folder (1976) promoting performance-oriented standards for energy conservation, rather than prescriptive standards. Free.

Available through Publications Fulfillment Office (626-7332).

Saving Energy in the Built Environment: The AIA Policy (6-N904)

Brochure (1975) summarizing two previous publications: "Energy and the Built Environment: A Gap in Current Strategies"; "A Nation of Energy Efficient Buildings by 1990." Free.

Available through Publications Fulfillment Office (626-7332).

The Solar Advantage (6-N820)

Pamphlet (1978) briefly describing current studies and legislation concerning solar energy. Results of recent research are applied to the energy efficiency of residences. Free.

Available through Director, Energy Programs (626-7448).

Solar Architecture (3-M234)

This 350-page book (1976) was prepared for ERDA by the Association of Student Chapters/AIA. Photo-illustrated reference describes the history, components, natural context, research and the future of solar design. A result of the ASC/AIA annual forum held in Tempe, Ariz., November 1975, it is a collection of expert presentations and panel discussions. Attendees included many of the nation's leading architects and researchers in the field. \$10.80/\$12.

Available through Director, Energy Programs (626-7448).

Solar Architecture (Environmental Communications)

Seventy color slides with booklet. Shows in detail more than 20 existing structures that effectively use the sun's energy. Illustrates buildings with passive solar heating, and buildings with various types of collectors and storage systems. Rent \$15 to AIA members only.

Available through Audiovisual Division, Library (626-7495).

State Energy Conservation Plans: Opportunities for AIA Components

Outlines options for AIA components' involvement in the Department of Energy's program financing supplemental state energy conservation plans and energy audits (1977).

Available through State Component Affairs Office (626-7386).

Solar Dwelling Design Concepts

(3-M311)

Report (1976) prepared by AIA Research Corporation on solar heating and cooling was prepared under contract to HUD for development as part of HUD's effort to demonstrate the feasibility of solar technology. A short history of solar applications, description of solar components and full systems, discussion of environmental factors and design concepts and case studies make up this comprehensive overview of current concepts in solar design. 146 pages; \$4.50/\$5.

Available through Publications Fulfillment Office (626-7332).

Wind Energy Poster (4-M233)

Front side handsomely illustrates the history of wind-harnessing devices for mechanical and electrical power from pre-Christian times to the present. Back side gives a comprehensive account of technical design information for modern wind energy conversion systems, and a list of manufacturers, research organizations and literature references. Includes a summary in French and German. Developed by Vonier and Wolff. Four-color, 24x30

inches. Single copy \$4, two or more (4-M233Q) \$3.25 each.

Available through Publications Fulfillment Office (626-7332).

For further information about energy, contact the Energy Office, 626-7448.

Environmental Design

The AIA Asks: Why? Why Not?:

Program Package 1 (6-N807)

25-page package (1974) that explains how to place a series of pictures and captions about good and bad environmental features in local newspapers. Describes the program, gives ideas for pictures and captions, provides "how-to" information about approaching the newspaper, etc. Free.

Available through Publications Fulfillment Office (626-7332) or Public Relations Department (626-7460).

Architecture and Your Life (4-Q101)

Color filmstrip, with teachers guide. Deals with the effect of architecture on man and the unprecedented responsibility of today's citizen for deciding upon the quality of the environment. 35mm; 50 frames; \$5. Available through Publications Fulfillment Office (626-7332).

Design Review Boards: A Handbook for Communities (2-M203)

Resume (1974) of the law on design review and an annotated model ordinance to guide communities that choose to adopt a design review board process. Published by AIA. 52 pages; \$5.60/\$7.

Available through Publications Fulfillment Office (626-7332).

Designscape

Color slides with reel-to-reel synchronized tape (1975). A visually delightful view of many of the old and new "designs" we see all around us. 160 slides; free loan to AIA members only.

Available through Audiovisual Division, Library (626-7495).

Environmental Impact Statements Bibliography

Four-page selected and annotated bibliography (1975) prepared by the AIA committee on architecture for commerce and industry. Free.

Available through the Library (626-7493).

Environments for People: Program Package 5 (4-N812)

Eighty slides, introduction, script and suggestions for use (1976). Explains how

architects provide for basic human needs (shelter, privacy, personalization, socializing, mobility, communication) in their design of the man-made environment. \$20.

Available through Publications Fulfillment Office (626-7332) or Public Relations Department (626-7460).

Guidelines for Environmental Aspects of the Practice of Architecture

Guidelines by the regional development and natural resources committee were adopted by the AIA board of directors to underline environmental concerns of AIA code of ethics. Free.

Available through Director, Design and Environment Programs (626-7363).

Life Experiences in Environmental Design (4-M127)

Interviews with students and recent graduates about their aspirations, travails, satisfactions, etc. Published by Association of Collegiate Schools of Architecture. 267 pages; \$4.

Available through Publications Fulfillment Office (626-7332) or The Association of Collegiate Schools of Architecture (785-2324).

Orchids and Onions: Program Package 4 (6-N811)

Folder (1975) explaining how components can carry on a program which asks the public to nominate organizations and individuals who made good or bad contributions to the man-made environment; a jury selects the winners. Based on a project of the Western Communities Architects' Association, a section of the Chicago Chapter/AIA. Free

Available through Publications Fulfillment Office (626-7332) or Public Relations Department (626-7460).

Socio-Physical Technology (2-M202)

Workshop report (1970) interrelating the efforts of experts from all disciplines involved in efforts to better the environment. Published by AIA. 38 pages; \$2.40/\$3.

Available through Publications Fulfillment Office (626-7332).

Spaces for the Species

Slide synchronized cassette tape presentation (1975) summarizing users' responses to various environments, such as a hotel, a school, an urban plaza and a shopping center. 30 minutes; free loan to AIA members only.

Available through Audiovisual Division, (626-7495).

For further information about environmental design in general, contact the Design & Environment Programs Office, 626-7363.

Environmental Education

Built Environment Education:

Program Package 10 (6-N824)

Folder highlighting a built environment education program for elementary school students developed and implemented by an architect. Includes a step-by-step sample program outline, plus a guide to resources and information on built environment education. Free.

Available through Publications Fulfillment Office (626-7332) or Public Relations Department (626-7460).

Environmental Education: Architecture's Role

Statement of the Institute's policy and initiatives in the area of environmental education. Includes discussion of 1970 Environmental Education Act, program examples and implementation suggestions. Companion publication to Environmental Education Legislation/Regulation. 23 pages; free.

Available through Director, Environmental Education (626-7573) and Director, State and Local Government Affairs (626-7386).

Environmental Education Legislation/Regulation: A Strategy Guide for AIA Components

Prepared by the environmental education committee to guide components in helping establish state legislation advancing environmental education. Includes model legislation. Companion publication to Environmental Education: Architecture's Role. 45 pages; free.

Available through Director, Environmental Education (626-7573) and Director, State and Local Government Affairs (626-7386).

Environmental Education Teaching Tools (6-N205-3)

Forty-page annotated catalog prepared by the environmental education committee, listing information on resources (books, games, films, etc.) for environmental education. Free.

Available through Director, Environmental Education (626-7573).

How to Conduct Environmental Education Workshops for Teachers and Architects (4-N205)

Guidebook documents and evaluates five workshops held to help train architects to function as resource people for built environmental education. 116 pages; \$2.

Available through Publications Fulfillment Office (626-7332).

Parallels: Teaching Architecture in Elementary and Secondary Schools

A descriptive case study written by an architect and a teacher who created and taught a course for Red Wing, Minn.,

sixth graders on the built environment. Brochure presents their goals and methods in parallel format for teachers and planning professionals. Individual copies, \$1; package of 50 copies for \$7.50.

Available through Minnesota Society/AIA, 314 Clifton Ave., Minneapolis, Minn. 55403. (612) 874-8771.

Streets (1976)

Curriculum for urban awareness program, grades 3-6, with a teacher's guide. Published through a grant from National Education Association and with the work of the Environmental Education Fund of the BSA. The manuals were prepared by The Architects Collaborative. Students Workbook and Teachers Guide \$7 plus \$2 handling. Teachers Guide (2) with 30 Student Workbooks. Contact Harwell Associates, Convent Station, N.J. 07961. *Available through Boston Society of Architects, 320 Newbury St., Boston, Mass. 02115, (617) 267-5175.*

A Teacher Introduction to Environmental Education (6-N205-2)

31-page booklet prepared by the AIA environmental education committee, intended to arouse interest about the built environment among teachers, with suggestions for classroom activities. Free. *Available through Director, Environmental Education (626-7573).*

Ethics

Code of Ethics and Professional Conduct (6-J330)

Two-page document published by the office of the secretary describing the canons, ethical standards and rules of conduct for AIA members as adopted by the board and members. Free.

Available through Publications Fulfillment Office (626-7332).

For further information about ethical matters, contact the Office of Assistant Secretary (626-7502).

Exhibits

An Act of Optimism: Building the Washington Cathedral

Illustrated Octagon exhibition catalog documenting the construction history of the Washington (D.C.) cathedral. Contains exhibition checklist and glossary of terms. 15 pages; \$1.25.

Available through the Octagon, 1799 New York Ave. N.W., Washington, D.C. 20006 (638-3105).

Architectural Exhibitions

Informative listing (1979, fourth edition) of sources of traveling architectural exhibitions for use by museums, galleries, schools, AIA chapters and public exhibition halls. Prepared by Kym Rice. Available through the Octagon, 1799 New York Ave. N.W., Washington, D.C. 20006 (638-3105).

Capital Losses

Illustrated checklist (1979), which accompanied exhibition on notable Washington, D.C., buildings destroyed since the 19th century. \$1. Available through the Octagon, 1799 New York Ave. N.W., Washington, D.C. 20006 (638-3105).

A Celebration of Diversity: Planning the International Center

Illustrated exhibition catalog (1979) on five of the 14 chanceries to be located on a 32-acre site in Northwest Washington, D.C. Architectural firms represented include Skidmore, Owings & Merrill, The Architects Collaborative and the Georgetown Design Group. \$1.50. Available through the Octagon, 1799 New York Ave. N.W., Washington, D.C. 20006 (638-3105).

Dolley and the 'Great Little Madison'

Illustrated exhibition catalog (1977) tracing the celebrated partnership of James and Dolley Madison, concentrating on their impact on American social development \$6. Available through the Octagon, 1799 New York Ave. N.W., Washington, D.C. 20006 (638-3105).

An Evaluation of Product Exhibits

Directed to the Architectural Profession
Fifteen-page publication (1976) showing the results of a survey conducted among architectural firms to discover the relative value of product exhibits and how to make such exhibits more valuable. Useful for components planning shows, and to manufacturers planning exhibits. Free. Available through Convention Office (626-7395).

Just for Fun!

Illustrated catalog (1979) from the Octagon's publicized exhibition on the history and development of architectural toys from the 18th century to the present. Limited supply. \$4.50. Available through the Octagon, 1799 New York Ave. N.W., Washington, D.C. 20006 (638-3105).

National, Regional and Local Exhibitions

The board of directors may grant approval to AIA members to participate in national exhibitions when the board finds that all such interests are fully protected

and when certain conditions are met.

The secretary of the Institute or state or regional components has authority to approve local and regional exhibitions. For further information, contact Office of Assistant Secretary (626-7502).

Two on Two at the Octagon

Exhibition catalog (1979) paying tribute to Chloethiel Smith, FAIA; Anne Tyng, FAIA; Ada Louise Huxtable, Hon. AIA, and Sarah Booth Conroy, Hon. AIA, and their impact on the urban environment. \$3.

Available through the Octagon, 1799 New York Ave. N.W., Washington, D.C. 20006 (638-3105).

Filing Systems**Uniform Construction Index: A System of Formats for Specifications, Data Filing, Cost Analysis, and Project Filing** (2-M200)

A comprehensive data filing format (1972) for design and construction information; a format for filing project correspondence; the CSI format for construction specifications; an estimator's cost analysis format, and a key word index interrelated with the specifications and data filing formats. \$9.60/\$12. Available through Publications Fulfillment Office (626-7332).

Financial Management**Architect/Engineer Supplement to Compensation Guidelines** (2-M188A)

Available only to architects and engineers, this is intended for in-house use when using cost-based approach to compensation. A discussion of issues that arise when negotiating with the client, it begins with a series of general considerations and deals with the subjects of adjustments and revisions to compensation, contingencies, methods of compensation and billing. 12 pages. \$2/\$2.50. Available through Publications Fulfillment Office (626-7332).

Compensation Guidelines for Architectural and Engineering Services, second edition (2-M188)

Prepared by AIA with the assistance of the American Consulting Engineers Council, this 160-page (1978) financial management tool places equal emphasis on both the architectural and engineering services required for building projects. Provides a rational process for relating design professionals' compensation to cost of services. Shows how to work with the client to analyze a project, item by

item, to reach an agreement on scope of services required. \$12/\$15.

Available through Publications Fulfillment Office (626-7332).

Financial Management for Architects (2-M724)

The "umbrella" of the AIA financial management system, this book covers basic theories and applications appropriate to all size firms of design professionals. Examines financial goals, profit planning, interrelationships of accounting reports and financial controls and the broad view of firm finances. \$22/\$27.50.

Available through Publications Fulfillment Office (626-7332).

Managing and Profiting from Cost-Based Compensation: A Mini-Guide (3-ST113)

A miniguide which helps the architect identify and agree upon with the client the services needed for a project, estimate the time and cost of these services, arrive at a fair compensation which is satisfactory to and adequately protects both parties, and, afterwards, manage the project and its costs for the maximum performance and profit. One copy needed per participant. \$3/\$3.35.

Available through Publications Fulfillment Office (626-7332).

Minnesota Management Studies

Research and survey information dealing with professional practice topics. 1980 studies include compensation management report and survey of architectural salaries (November 1980), \$5.

Available through Minnesota Society AIA, 314 Clifton Ave., Minneapolis, Minn. 55403, (612) 874-8771.

Opportunities for Life Income Agreement: The Gift that Pays You Income for the Rest of Your Life.

Booklet describing the various ways that you can give and have your investment returned to you. Free.

Available through the Octagon, 1799 New York Ave. N.W., Washington, D.C. 20006 (638-3105).

Standardized Accounting for Architects (2-M705)

First published in 1950, this extensively revised manual (1978) brings the accounting system presented into conformity with the entire AIA financial management system. It is designed to provide a simple record-keeping procedure that will yield appropriate financial data for routine tax and accounting purposes and for monitoring the operations of a firm. The double-entry system of bookkeeping employed in this book allows the use of

Fi

either the cash basis or the accrual basis for accounting. Subjects covered include: basic accounting principles, standardized accounting procedures, the basic system and the cash journals, adjusting and closing cash journals, and payroll and project expense accounting. A glossary of terms is provided. \$16/\$20.
Available through Publications Fulfillment Office (626-7332).

For further information about financial management in general, contact the Practice Office, 626-7457. AIA accounting and financial management forms are listed under AIA Documents.

Firesafety

Educating the Architect: Fire and Life Safety

33-page report (1975) prepared by the AIA task group on fire and life safety, documenting the need for better firesafety curricula in education, and a program to implement the proposed recommendations. Free.
Available through Codes and Standards Office (626-7456).

For further information about firesafety, contact the Codes and Standards Office, 626-7456.

Funding

Funding Sources for Architectural Programs: Foundations Supporting the Built Environment (2-M719)

A resource listing compiled by the AIA Foundation and the National Endowment for the Arts. Contains essential information on more than 200 foundations that support the built environment. \$8/\$10.
Available through Publications Fulfillment Office (626-7332).

Government Affairs— National

AIA Legislative Program

Annual one-page list containing an abbreviated description of AIA policies related to congressional issues. Free.
Available through Congressional Liaison Office (626-7379).

Architects in Government Roster (2-M161)

List (1980) giving names and addresses

of architects employed by federal, state and local governments. \$5/\$6.
Available through Publications Fulfillment Office (626-7332).

Congress of the United States

Brochure containing names and party affiliations of representatives and senators. Arranged by state or territory. Free.
Available through Congressional Liaison Office (626-7379).

Congressional Contact System

Service to any AIA member who wishes to visit his/her representatives and senators. Information on pertinent legislative issues, a member's committee assignments, AIA policies, etc., are offered on request.

Contact Congressional Liaison Office (626-7379).

Federal Programs Conference

Annual conferences sponsored by AIA and the engineering societies. Provides opportunities for A/E professionals to meet key government officials from more than 52 federal agencies and Congress.
Contact Federal Agency Liaison Office (626-7382).

Legislative Minuteman Program

Nationwide system used by the Institute to communicate with individual members of Congress through practicing architects in their home states who personally know representatives or senators or who are simply willing to contact them on issues of importance to the profession.
Contact Congressional Liaison Office (626-7379).

Legislative Minuteman Program Flyer

Biennial flyer describing the program. Includes registration card. Lists some of the accomplishments of the program. Free.

Contact Congressional Liaison Office (626-7379).

Special Obligations: Issues in the Administration of Public Architecture

Thirty-page report (1977) summarizing the forum on public architecture held in 1976 and jointly sponsored by AIA's architects in government committee and the federal architecture project of the National Endowment for the Arts. This is intended to focus national attention on the special responsibilities and special problems of everyone involved in public building—both architects and administrators.
Contact Component Affairs Office (626-7387).

Working in Government: A Profile Study of the Architect as a Public Employee (2-M712)

Prepared by the AIA architects in government committee (1978), the information presented in this report is intended

to give the general public a better understanding of the various functions performed by architects in government; to give educators a clearer view of educational needs and opportunities, and government administrators an opportunity to make comparative assessments of architects in various agencies and at various levels of government. Developed from a survey of more than 2,000 architects in government conducted in 1976, it provides a comprehensive profile of those persons practicing as architects in the public sector. \$5/\$6.
Available through Publications Fulfillment Office (626-7332).

For further information about congressional activities, contact Congressional Liaison Office, 626-7379. Questions relating to federal agencies should be directed to Federal Agency Liaison Office, 626-7382.

Government Affairs— State & Local

Architect/Engineer Government Contracting: A Manual (4-M718)

In loose-leaf format, this convenient, easy-to-read manual (1979) contains actual forms, documents, regulations, laws, guidelines and techniques used by public officials and design practitioners in A/E contracting. Prepared by the Committee on Federal Procurement of A/E Services (COFPAES), it is available for the first time outside the successful contracting course. \$95.

Available through Publications Fulfillment Office (626-7332).

Architect Selection: Legislative Guidelines for Public Construction

55-page publication (revised 1977) which contains two model bills for A/E selection for public construction projects and copies of state A/E selection laws. Free.
Available through State Component Affairs Office (626-7386).

Architects in Government Roster (2-M161)

List (1979) giving names and addresses of architects employed by federal, state and local governments. \$5/\$6.
Available through Publications Fulfillment Office (626-7332).

Architects at the Legislature: Lobbying for a Statute of Limitations

Case studies reflecting both successful and unsuccessful lobbying efforts by AIA

components and related organizations in Missouri, Minnesota and Illinois.

Available through State Component Affairs Office (626-7386).

Community Development Block Grants: Opportunities for Shaping Urban Growth

Identifies for local government officials and concerned citizens those provisions of Title I which provide opportunities for implementing AIA's principal urban growth policy recommendations and how architects can participate. Free.

Available through State Component Affairs Office (626-7386).

Compendium: Architect Selection Laws (6-N509)

Contains laws of 18 states that now have specific legislation regulating the selection of architects for public construction projects. Appendix contains a list of state agencies responsible for implementing these laws and the federal A/E procurement (Brooks) law. Free to AIA members; \$5, nonmembers.

Available through Publications Fulfillment Office (626-7332).

Compendium: State Statutes of Limitations (6-N510)

Compilation of the state statutes of limitations relating to design professionals and the construction industry. Free to AIA members; \$5, nonmembers.

Available through Publications Fulfillment Office (626-7332).

Direct Government Affairs Assistance

Direct assistance to components in the form of on-site consultation and resource documents for those seeking to expand established government affairs activities or focus on individual issues. Consultation by component officers and executives and Institute staff.

Contact State Component Affairs Office (626-7386).

Environmental Education Legislation/Regulation: A Strategy Guide for AIA Components

Publication prepared by the environmental education committee guide components in helping establish legislation advancing environmental education. Includes model state legislation. Companion publication to Environmental Education: Architecture's Role. 45 pages; free.

Available through State Component Affairs Office (626-7386).

Environmental Education: Architecture's Role

Twenty-three-page publication discusses the role of architecture in environmental education, describes federal and state leg-

islation and programs, and provides suggestions for implementing environmental education programs.

Available through State Component Affairs Office (626-7386), or Director Environmental Education (626-7573).

Environmental Education Legislation/Regulation: A Strategy Guide for AIA Components

Booklet presents AIA policy on environmental education, contains state legislative guidelines and strategies for implementing a statewide program. 45 pages.

Available through State Component Affairs Office (626-7386), or Director Environmental Education (626-7573).

Forum on Public Architecture: A Conference for Government Administrators—A Resource Book

Collection (1976) of articles on public architecture, presenting significant state and local activity in such areas as energy conservation, land use and adaptive use. 142 pages; free.

Available through State Component Affairs Office (626-7386).

Government Alert for Components

Bulletin published six times a year containing brief, timely reports on government affairs developments at the state and local level. Free.

Available through State Component Affairs Office (626-7386).

Governmental Information Clearinghouse

A service to provide components with information on state and local issues of professional and public concern. Materials available include copies of legislation, administrative rules, government studies and reports, AIA documents and other background materials. Includes data on liability, energy, registration, etc.

Contact State Component Affairs Office (626-7385).

How to Organize an Effective Government Affairs Program

Guide (1975) for improving component government affairs programs. Includes information on the purpose and structure of such programs, the legislative process and state governmental contact systems. 40 pages; free.

Available through State Component Affairs Office (626-7386).

How To Work Effectively with State Legislatures

Publication (1969) by the American Society of Association Executives, advising associations on establishment of a legislative program, lobbying, campaigning and evaluating a legislative session. 44 pages; free.

Available through State Component Affairs Office (626-7386).

Innovations in State Legislation:

Land Use Management Environment and Land-Use: Two California Experiments

Two publications (1973 and 1975) by Richard N. Tager, offered as one unit.

The first is an overview of the role states can play in implementing the fundamental recommendations of the AIA national policy task force. The second report discusses the background and fundamental provisions of CEQA and the Coastal Zone Act.

Available through Design and Environment Programs Office (626-7363).

Involving Architects in the Community Development Block Grants Programs: A Strategy Guide for AIA Components.

For components' use, providing guidance in the CD block grant planning and application process to encourage local AIA involvement in the programs. Free.

Available through State Component Affairs Office (626-7386).

License Renewal Legislation/Regulation: A Strategy Guide for AIA Components

Publication discusses the issue of license renewal for architects, outlines potential action by components and contains legislative and regulatory guidelines for components. 24 pages.

New License Renewal Requirements for Architects: The AIA's Policy and Initiatives

Document presents AIA policy on license renewal, describes the principles of the professional development measuring system and discusses current state activity on license renewal. Companion publications. 21 pages.

Both available through State Component Affairs Office (626-7386).

Lien Laws for Design Professionals: A Survey and Analysis (4-N511)

Study (1980) of lien laws in each state and their applicability to architects and engineers as well as related court rulings. Free to AIA members; \$5, nonmembers.

Available through Publications Fulfillment Office (626-7332).

Original State and Local Government Programs Documents—Legislative Guidelines and Strategies

These documents may include model legislation, legislative guidelines, background information and strategies for component action on significant governmental issues.

Contact State Component Affairs Office (626-7386).

Political Action: A Strategy Guide for AIA Components

Document written to encourage architect involvement in the political process, as individuals and through components. Information is included on political action committees, "Meet the Candidates Nights" and calendars for state and local elections. 32 pages.

Available through State Component Affairs Office (626-7386).

Special Obligations: Issues in the Administration of Public Architecture

A summary of conference presentations and discussions between state and local government administrators concerning constraints and opportunities in public architecture. Free.

Available through State Component Affairs Office (626-7386).

State/Local Government: Issues & Strategies (6-N508)

Reference notebook (1979) for AIA components and architects working on government affairs issues. Revised annually, it contains sections on major issues, strategies, case studies and space for component materials. \$20 to AIA members only.

Available through Publications Fulfillment Office (626-7332).

Sunset Laws: A Strategy Guide for AIA Components

Publication discussing sunset legislation, how sunset reviews can affect architecture-related matters and strategies for effective participation in sunset reviews. 46 pages; free.

Available through State Component Affairs Office (626-7386).

Sunset Laws Review: Architect Registration Boards

Discusses the experiences of states which have recently had sunset reviews of the architect registration boards (May 1980).

Available through State Component Affairs Office (626-7386).

What Is Your Stake in Government Affairs?

Pamphlet designed to encourage political action by AIA members. Free. Available in quantities.

Available through State Component Affairs Office (626-7386).

For further information about state component government affairs activities, contact State Component Affairs Office, 626-7385 or 626-7386.

Guidebooks

AIA Guide to New York City,

Revised edition. (3-M383)
A street-by-street guide to the city's buildings of historic and architectural interest, shows, theaters, parks and squares. \$9/\$9.95.

Available through New York Chapter/AIA, 457 Madison Ave., New York, N.Y. 10022, (212) 759-5485 (add \$2.75 for postage and handling) or Publications Fulfillment Office (626-7332).

AIA Guide to the Architecture of Washington, D.C. (3-M269)

Convention guidebook (1974) prepared by the Washington Metropolitan Chapter/AIA, on the architecture of Washington, D.C. 246 pages; \$6.25/\$6.95.

Available from Publication Fulfillment Office (626-7332).

Architecture Boston

A guide to the architecture of Boston with a foreword by Walter Muir Whitehill; text by Joseph Eldredge, FAIA (1976). \$5.95 plus \$1.50 postage and handling.

Available through Boston Society of Architects, 320 Newbury St., Boston, Mass. 02115, (617) 267-5175.

Austin and Its Architecture

A portrait of Austin. Hardback, with 485 photographs, hundreds of little-known facts, buildings, places, trees—the whole town in words, maps and pictures. \$10.75/\$12.75.

Available through Austin Chapter/AIA, 709 W. 15th Street, Austin, Tex. 78701 (512) 477-3318 or Texas Society of Architects/AIA, 2121 Austin National Bank Tower, Austin, Tex. 78701, (512) 478-7386.

A Bus Tour of Minneapolis Architecture

The Minnesota Society/AIA historic resources committee created a tour map of 26 sites along one of Minneapolis' primary bus routes from the University of Minnesota to the Southdale Shopping Center, highlighting both historic and contemporary sites. Free to AIA components, \$1 handling to others.

Available through Minnesota Society AIA, 314 Clifton Ave., Minneapolis, Minn. 55403, (612) 874-8771.

Detroit Architecture

Guide (1971) to the architecture of Detroit. \$3.25.

Available through the Octagon, 1799 New York Ave. N.W., Washington, D.C. 20006 (638-3105).

Historic Wisconsin Architecture

A guidebook (revised edition, 1976) to historic buildings in Wisconsin, containing sections on Frank Lloyd Wright, Louis

H. Sullivan, Purcell & Elmslie. Pictures, maps and short descriptions of more than 100 buildings. \$2, plus \$.50 postage and handling.

Available through Wisconsin Society of Architects/AIA 615 E. Washington Ave. Madison, Wis. 53703, (608) 257-8477.

The Houston Coloring Book

A simple alphabetical guide for touring in Houston. The book (1976) depicts buildings, parks and other significant landmarks in and around the city. It is aimed at children, but adults will find it a delightful city souvenir. Free.

Available through Houston Chapter/AIA, 3121 Buffalo Speedway, Suite 404, Houston, Tex. 77098, (713) 629-0191.

Indianapolis Architecture

Views of Indianapolis by neighborhoods, including more than 500 photographs, paralleling the development of the city's history. Published by the Indiana Architecture Foundation, it is indeed a third generation guidebook. \$6.95, plus \$1 for handling.

Available through Indiana Society of Architects/AIA, 148 N. Delaware St., 46204, (317) 634-3871.

Indianapolis Architecture Guidebook: Program Package 8 (6-N826)

A folder (1977) describing the process by which Indianapolis Chapter/AIA published an extensive guidebook of that city. Includes sections on why to write a guidebook, forming a committee, fund-raising, budgeting, selecting printer and designer, and publicizing the project and the product. Free.

Available through Publications Fulfillment Office (626-7332).

Kansas City

A guide to Kansas City's historic and contemporary architecture by neighborhoods. This soft cover, pocket size, book contains 256 pages of black and white photographs of 300 buildings. Published by the Kansas City Chapter/AIA in conjunction with the 1979 "Celebration of Architecture." \$6.95, plus \$1.25 handling.

Available through Kansas City Chapter/AIA, 20 W. Ninth St., Kansas City, Mo. 64105, (816) 221-3485.

Walking Map of Downtown St. Louis

Shows location of buildings of historical interest. Free. Please send stamped self-addressed envelope. Laclede's landing map and list of architects' Sunday tours also available upon request.

Available through St. Louis Chapter/AIA, 919 Olive St., St. Louis, Mo. 63101, (314) 621-3484.

Welcome to Los Angeles: An Architectural Discovery Map. (L.A. Architect, June 1977).

Three-page folded guide to Los Angeles. First section is a map of Los Angeles and Los Angeles County. Numbers on the map correspond to photos in the next section which depict a cross-section of L. A. architecture from 1750 to 1977. The third section includes a time-line of architectural history in L. A. along with a brief description of each of the buildings photographed in the above section. \$1 plus tax and postage.

Available through Los Angeles Chapter/AIA, 8687 Melrose Ave., Los Angeles, Calif. 90069, (213) 659-2282.

Westbrook

Booklet with maps, illustrations and drawings which document the history of Westbrook in Surrey, England, home of Gen. James Edward Oglethorpe, founder of Georgia. \$5 plus postage.

Available through the Georgia Association/AIA, Peachtree Center/Cain Tower Lobby, 229 Peachtree St., Atlanta, Ga. 30303, (404) 524-3877.

Historic Preservation

Adaptive Re-Use: Extending the Life of Old Buildings (6-N827)

Written by AIA's PR department as an informative piece for the general public (1979), this pamphlet features a description of four honor award-winning buildings which exemplify this important trend in architecture: Boston's Faneuil Hall, San Francisco's Cannery and Ghirardelli Square and Chicago's Navy Pier. Free. *Available through Publications Fulfillment Office (626-7332) or Public Relations Department (626-7460).*

The Architect as a Preservationist (1-HBC21)

Chapter 21 (1971) of the Architect's Handbook of Professional Practice, this document includes an introduction to preservation, its elements, basic architectural services, compensation for architectural services and supplementing the standard forms of agreement. \$.60/\$.90. *Available through Publications Fulfillment Office (626-7332).*

Conserving Architectural Resources

An annotated bibliography published by the committee on historic resources of the Boston Society of Architects, 1978. "... Present(s) a range and selection of publications which will advance the conservation of architectural resources. . . ." \$5 includes handling.

Available through Boston Society of Architects, 320 Newbury St., Boston, Mass. 02115, (617) 267-5175.

Guide to Historic Preservation (4-N301Q)

Prepared by the AIA committee on historic resources, this booklet (1978) explains preservation services from the pre-design and research phase through the construction and contract administration phase. It also discusses the preservation team, preservation benefits, costs and selection of an architect. \$10 per 100 copies.

Available through Publications Fulfillment Office (626-7332).

Guidelines for Preservation, Restoration and Alterations to the Central Library of Los Angeles

Report (1979) by the Los Angeles Chapter/AIA library study team. \$5 plus tax and postage.

Available through the Los Angeles Chapter/AIA, 8687 Melrose Ave., Los Angeles, Calif. 90069, (213) 659-2282.

Our Vanishing Heritage

Why hold on to our past? What is historically valuable? Published by the historic resources committee of the Boston Society of Architects. \$2 postpaid.

Available through Boston Society of Architects, 320 Newbury St., Boston, Mass. 02115, (617) 267-5175.

Restoring a Landmark

Poster showing cross section of the Octagon, Plate XII from Glenn Brown's 1914 monograph. 24x32 inches. \$4.50 postpaid.

Available through the Octagon, 1799 New York Ave. N.W., Washington, D.C. 20006, (638-3105).

Stations

Color film, 16mm, 28 minutes (1974).

Shows many of the interesting and innovative uses being made of old railroad stations, in order to preserve these landmarks. Rent \$15 to AIA members only. *Available through Audiovisual Division, Library (626-7495).*

The Texas Historical Preservation Manual

Published in three-hole binder by TSA's historic resources committee, the aim is to aid and educate architects and laymen in the practice of preservation, restoration and adaptive use of older buildings. Includes sections on the history of preservation in Texas, preservation and the law, procedures for obtaining funds for preservation, procedures of the Register of Texas Historical Monuments and of the National Register of Historic Places, case histories, etc. Designed to be expanded and updated. \$20.

Available through Texas Society of Architects/AIA, 2121 Austin National Bank

Tower, Austin, Tex. 78701, (512) 478-7386.

William Thornton: A Renaissance Man in the Federal City

Exhibition catalog (1976) for the exhibition held at the Octagon on the 18th century architect of the U.S. Capitol and the Octagon. Prepared by David N. Yerkes, FAIA, and Elinor Stearns. 58 pages; 46 black and white illustrations. \$3.75 postpaid.

Available through the Octagon, 1799 New York Ave. N.W., Washington, D.C. 20006 (638-3105).

For further information about historic preservation in general, contact the Professional Interest Programs Office, 626-7366.

Housing

Homeowner's Reminders

Pamphlet (1978) for public use. Includes tips for homeowners on home security, water problems, saving energy, termites, contracting for home improvement, and on architects. 15 pages; free.

Available through Michigan Society of Architects, 553 E. Jefferson, Detroit, Mich. 48226, (313) 965-4100.

Homes for Better Living Awards

Brochure describing the annual award program open to custom-designed houses, merchant-built houses and multifamily housing in the U.S. and its possessions. Sponsored by AIA in conjunction with *Housing* magazine. Contains eligibility requirements, submission procedures, entry dates and a tear-off entry slip. Free.

Available through Awards Division, Office of Assistant Secretary (626-7390).

Shelter (Environmental Communications)

One hundred color slides with booklet. Depicts various shelters from around the world; includes hand-built houses, yurts, domes, tents, cottages, barns and free-form sculptured dwellings. Rent \$15 to AIA members only.

Available through Audiovisual Division, Library (626-7495).

Survey of Southern California Housing (Environmental Communications)

One hundred color slides with booklet. Illustrates the great variety of housing, including mansions in Beverly Hills, "cliff-hangers" in Hollywood, the ghetto in Watts, beach places in Malibu and apartment buildings and housing throughout the area. Rent \$15 to AIA members only.

Available through Audiovisual Division, Library (626-7495).

In

For further information about housing in general or housing for the elderly, contact the Professional Interest Programs Office, 626-7364. Questions about barrier-free design should be directed to Codes & standards Office, 626-7453.

Industrial Architecture

Architects in Industry Seminar

Annual seminar that brings together architects employed by commercial and industrial corporations to oversee their planning, design and construction programs. Interchange provides architects in industry with resources to improve the quality of design and professional services for the corporate client. Oct. 12-15, 1980, Williamsburg, Va. Contact Professional Interest Programs Office (626-7364).

For further information about industrial architecture in general, contact the Professional Interest Programs Office, 626-7364.

Insurance

Benefit Insurance Programs Commended by AIA

Major medical insurance for firms and individuals, accidental death and dismemberment for individuals, disability income for individuals, hospital confinement for individuals.

Contact Association Administrators and Consultants, Inc., 800-854-0491. In Alaska, California and Hawaii, dial collect 714-833-0673.

Professional liability program.

Contact Victor O. Schinnerer & Co., Inc. 5028 Wisconsin Ave. N.W., Washington, D.C. 20016.

Life insurance for firms.

The AIA Insurance Trust, 1612 K St. N.W., Washington, D.C. 20006.

Life insurance for individuals.

Group Administrators, Inc., Suite 520, 888 17th St. N.W., Washington, D.C. 20006.

Construction Bonds and Insurance Guide second edition (2-M163)

Loose-leaf reference book (1979) prepared by Bernard B. Rothschild, FAIA, containing information on bonds and insurance related to construction projects, with glossary of insurance terms and suggested checklist. \$16/\$20.

Available through Publications Fulfillment Office (626-7332).

Insurance and Bonds of Suretyship

(1-HBC7) Chapter 7 (1969) of the Architect's Handbook of Professional Practice, this document outlines professional insurance, personnel insurance, office insurance, owner and contractor insurance, bonds of suretyship, prototype letters, certificate of insurance and a checklist on protection. \$1.20/\$1.80.

Available through Publications Fulfillment Office (626-7332).

Professional Liability Insurance Flyer

Brief two-page report on the high points of PLI and a list of the insurance carriers currently selling this insurance. Free.

Available through Practice Division, Liability Program (626-7458).

Professional Liability Insurance Survey

Survey report describing coverages, policy structure and claims network of the seven major liability insurance companies. Free. Available in October through Liability Program Office (626-7458).

Project Liability Insurance Flyers

Two brief folders, prepared by Victor O. Schinnerer & Co., outlining a new concept in professional liability insurance on a per project basis. Free.

Available through Liability Program Office (626-7458).

The Techniques of Professional Liability Loss Prevention

Techniques of successful loss prevention. A practical approach to professional liability. 112 pages; \$20.

Available through Colorado Society of Architects/AIA, 1420 Larimer Square, Denver, Colo. 80202, (303) 629-0759.

For further information about liability insurance, contact the Liability Program Office, 626-7458.

Questions about benefit insurance should be directed to the Department of Business Management, Office of the Controller, 626-7322.

Interiors

1981 New Products Guide, Vol. 1, Interiors (NPG/1)

North Central states regional products catalog featuring new and innovative products including office equipment, finishes, furnishings, specialties, wood, plastics and lighting.

Available through Minnesota Society AIA, 314 Clifton Ave., Minneapolis, Minn. 55403 (612) 874-8771.

Scope of Services of Interior Architecture (AIA Committee on Interior Architecture)

Color slides (1980) with script describing the array of services architects provide in

interior design, relating these services to AIA Document B171, "Standard Form of Agreement for Interior Design Services." Two-hundred slides designed for two projectors and two screens, but can be shown with a single projector and screen. Free loan: AIA members only.

Available through Audiovisual Division, Library (626-7495).

International Relations

Architect's Guide to International Practice (2-M715)

Produced through the efforts of AIA's federal agency liaison department, this book (1978) comes in response to requests for information about overseas work. The guide contains pertinent facts on 29 foreign countries, acquainting architects with the complexities and legal/financial considerations for practicing abroad as well as the differences between foreign and domestic markets. It also presents an overview of international practice and discusses the merits of using the services of overseas representatives and establishing an overseas presence with a local firm. \$16/\$20.

Available through Publications Fulfillment Office (626-7332).

For further information about international relations, contact the International Relations Office, 626-7549.

Joint Ventures

Development Building: The Team Approach (2-M135)

Book (1972) by C. W. Griffin. A guide to project development. Published by AIA. 130 pages; \$16/\$20.

Available through Publications Fulfillment Office (626-7332).

Interprofessional Agreements (1-HBC10)

Chapter 10 (1975) of the Architect's Handbook of Professional Practice, this document covers working relationships, architect-consultant agreements, architect-engineer agreement forms and joint venture agreements. \$.60/\$.90.

Available through Publications Fulfillment Office (626-7332).

Justice Facilities

Architecture for Justice Exhibit

An annual exhibit, jointly sponsored with the American Correctional Association, of recent facilities for corrections, courts in

and law enforcement. Information and registration material for the 1981 exhibit will be available in March 1981.

Contact Professional Interest Programs Office (785-7429).

Design Resource File: Planning Justice Facilities (4-M714)

This resource, prepared in 1978 by the AIA committee on architecture for justice, contains: the 1972 report of the AIA task force on correctional architecture, summarizing its observations on the state of the art in architecture for justice and some recommendations for action; guidelines for the justice planning process; resource and bibliographies pertaining to court facilities, correctional facilities and juvenile justice; an evaluation checklist for law enforcement facilities. \$10.

Available through Publications Fulfillment Office (626-7332).

For further information about justice facility planning, contact the Professional Interest Programs Office, 626-7429.

Land Use

Coastal Zone Management: Balancing Growth Protection

Coastal Zone Management: Component Guide. These two booklets assist coastal state components in positive action toward effecting coastal zone management plans with design input in their states. Free.

Available through State Component Affairs Office (785-7386).

Innovations in State Legislation: Land Use Management

Environment and Land-Use: Two California Experiments

Two publications (1973 and 1975) by Richard N. Tager, offered as one unit. The first is an overview of the role states can play in implementing the fundamental recommendations of the AIA national policy task force. The second report discusses the background and fundamental provisions of CEQA and the Coastal Zone Act. Free.

Available through Design and Environment Programs Office (626-7363).

Something This Good Can Last Forever

Three 30-second television spots (1975), stressing importance of land use planning and showing a variety of urban and rural scenes to demonstrate benefits of intelligent land use. One spot is on George Washington as surveyor. AIA requires knowledge of stations using spots. Free.

Available through Public Relations Department (785-7260).

For further information about land use in

general, contact the Design and Environment Programs Office, 626-7363.

Legal Concerns

Legal Concerns (1-HBC19)

Chapter 19 (1969) of the Architect's Handbook of Professional Practice, this document includes information on the law and legal profession, licensing, legal responsibility, professional liability, liability insurance, entering practice, contracts, the contractor and the law, the owner and the law, mechanics liens, arbitration and expert witnesses.

\$1.20/\$1.80.

Available through Publications Fulfillment Office (626-7332).

Legal Study Program

Selected architect/law students may receive academic credit for a part-time work-study program concerned with legal matters and contract documents.

Contact Documents Office (626-7454).

Lien Laws for Design Professionals:

A Survey and Analysis (4-N511)

Study (1980) of lien laws in each state and their applicability to architects and engineers as well as related court rulings. Free to AIA members; \$5, nonmembers.

Available through Publications Fulfillment Office (626-7332).

Office of General Counsel

The general counsel and deputy general counsel serve as corporate legal advisers to AIA, its related corporation and to components regarding the corporation bylaws, contracts, antitrust and tax matters and other activities.

Contact Office of General Counsel (785-7389).

Summer Legal Intern

An architect/law student is selected each year to spend the summer working at AIA headquarters on contract documents and legal concerns.

Contact Documents Office (626-7454).

For further information about legal concerns in general, contact the Documents Office, 626-7454.

Library

AIA Library Cross-Referenced Awards File

All AIA honor and merit awards have been indexed by date, place, architect, name of project and building type. The library staff can answer questions such as how many houses in Chicago have won AIA awards, etc.

Contact Library (626-7493).

Association of Architectural Librarians Meeting

Held annually in conjunction with the AIA national convention for librarians from schools of architecture, firms and special libraries.

Contact the Library (626-7493).

Bibliographies of AIA Library Holdings and Periodical Articles

The library staff will prepare on request bibliographies of library books and/or periodical articles on specific subjects or building types. Members can identify books they wish to borrow from these lists. Free. Library has no photocopying facilities.

Contact the Library (626-7493).

Bibliography of Bibliographies

Four-page list (1978) of subject bibliographies compiled by the library staff. Contains approximately 200 subjects on which bibliographies of the library's holding and/or periodical articles have been prepared. Free.

Available through Library (626-7493).

Biographical Information on Architects

The library will attempt to provide biographical information on individual architects, using reference sources such as the Baldwin Memorial Archive of American Architects.

Contact the Library (626-7493).

Book Loans

Members may borrow up to six books at one time from the AIA library for a two-week loan period. The only charge for this service is return postage via UPS or insured mail.

Contact the Library (626-7493).

Library Research Services

The library staff will respond to questions, either in person, by telephone or by letter, on aspects of architecture and construction, architectural history, building types, etc., using the library's catalogued volumes, more than 400 current periodicals, reference books and indexes. Free.

Contact the Library (626-7493).

Recent Acquisitions

Bimonthly list of recent library acquisitions, arranged by subject. \$1/year.

Available through the Library (626-7493).

Services to Members

Sheet (1980) describing the AIA library's services to AIA members. Free.

Available through the Library (626-7493).

For further information about the AIA Library, contact the Library directly,

Li

626-7493. Questions regarding audio-visual materials should be directed to the Audiovisual Division, 626-7495.

Lighting

Current Techniques in Architectural Lighting (3-S223)

Cassette and slides (1975) illustrating a wide range of lighting situations and solutions. \$13/\$14.50.

Available through Publications Fulfillment Office (626-7332).

Marketing

Achieving Results with Words (4-T104)

This 10-unit program, delivered in two sections, helps develop written communication skills necessary to sell ideas. \$110. Available through Professional Development Office (626-7355).

Conducting Winning Presentations (4-T105)

An eight-step correspondence course dealing with techniques of conducting presentations, client reaction and follow-through. \$95 for the first person; \$25 for each additional person (4-T105A).

Available through Professional Development Office (626-7355).

Designing Your Brochure as an Aid in Marketing Your Services (3-S224)

This one-hour cassette (1976) tells you how to gear your brochure to your desired market by making it convey your firm's personality, your ability to take care of the client, your problem-solving ability, the range of your services, etc. The contents of an "ideal" brochure are outlined. \$9/\$10.

Available through Publications Fulfillment Office (626-7332).

Marketing Architectural Services (1-HBC-B-8)

Chapter 20 (1980) of the Architect's Handbook of Professional Practice, this document covers current trends, AIA studies, types of comprehensive services, firm organization and operation, owner-architect agreements and the use of the Handbook \$1.50/\$2.25.

Available through Publications Fulfillment Office (626-7332).

Marketing Architectural Services Game Seminar (4-T103)

Correspondence course to help firms develop effective marketing programs. Each study group limited to six people. First person: \$85; each additional person \$25 (4-T103A).

Available through Professional Development Office (626-7355).

Selling Architectural Services (3-S207)

Cassette (1973) showing how the architect can conduct a practice in a professional and more prosperous manner by using effective marketing techniques. \$9/\$10.

Available through Publications Fulfillment Office (626-7332).

Selling Architectural Services II (3-S218)

This cassette (1975) examines the person-to-person selling process. It focuses on how to understand and work with your client's problem, achieving a mutually beneficial client-architect relationship. \$9/\$10.

Available through Publications Fulfillment Office (626-7332).

Successful Selling of Professional Services: Winning the Contract Before the Presentation (4-T106)

Six-section, learn-by-doing course which teaches through a series of typical case studies how to consistently improve your selling outcomes. \$85.

Available through Professional Development Office (626-7355).

Meetings

AIA National Convention

Annual conference for all AIA members, where officers are elected, product information displayed, workshops and seminars presented, etc. Location and registration fee vary.

Contact Convention Office (626-7395).

Architects in Industry Seminar

Annual meeting brings together architects employed by commercial and industrial corporations to oversee their planning, design and construction programs. Interchange provides architects in industry with resources to improve the quality of design and professional services for the corporate client. Oct. 12-15, 1980, Williamsburg, Va.

Contact Professional Interest Programs Office (626-7366).

ASC/AIA Student Forum

Annual convention held over the Thanksgiving holidays brings together architectural students from around the country. Forum '80 will be held in Philadelphia.

Contact Association of Student Chapters/AIA, at AIA Headquarters (626-7472).

Association of Architectural Librarians Meeting

Annual meeting held in conjunction with the AIA national convention, of librarians from schools of architecture, firms and special libraries.

Contact the Library (626-7493).

Convention Hall Checklist

List prepared by the American Society of

Association Executives: what not to forget to do when planning a convention or meeting. Free.

Available through Convention Office (626-7395).

Federal Programs Conference

Annual conference sponsored by AIA and the engineering societies. Provides opportunities for A/E professionals to meet key government officials from more than 52 federal agencies and the Congress.

Contact Federal Agency Liaison Office (626-7382)

Grassroots

Regional meetings held in January of each year bringing component officers and executives together with national officers and staff. Purpose is to review and discuss national programs and policies, give component leaders an opportunity to participate in the national planning process and provide a forum for the exchange of ideas among components. Program will be held only once in 1981, in Washington, D.C.

Contact Component Services Office (626-7377).

Information on Convention Cities

Various brochures, maps and other general information about the city in which the AIA national convention will be held. Free.

Available through the Convention Office (626-7395).

Meetings and Conferences Budget Checklist

Sample budget outline to aid meeting planners in staying within their budgets. Reminder of items to be considered in planning. Free.

Available through the Convention Office (626-7395).

Schedule: Regional and State Conventions and Expositions

Annual schedule of meetings to be held by components, including place, expected attendance and contacts. Free.

Available through the Convention Office (626-7395).

Site Inspection Checklist

Checklist prepared by the American Society of Association Executives as an aid to those preparing meetings: what to look for, items to remember. Free.

Available through the Convention Office (626-7395).

For further information about meetings in general, contact the Convention Office (626-7395).

Membership

AIA Membership Directory (4-M136)

Annual alphabetical listing of AIA members, including addresses and chapter affiliations. Appendices includes honorary members and fellows, component presidents, medals and awards, affiliated and associated organizations. \$10/\$60.

Available through Publications Fulfillment Office (626-7332).

Membership Bulletin

Bulletin published periodically containing current membership information, timely suggestions for membership recruitment and retention for use of component membership chairpersons, president and executives. Free.

Available through the Component Services Office (626-7377).

Membership Forms/H Series

The following forms are intended for components' use. Free.

H301 Application for Membership

H302 Application for Associate Membership

H303 Favorable Recommendation of Chapter on Application for Membership

H305 Recommendation of Chapter for Unfavorable Action on Application for Membership

H351 Application for Professional Affiliateship

H601 Application for Membership Emeritus

H713 Favorable Recommendation for Remission of Institute Dues

Available through Membership Records Division, Office of Assistant Secretary (626-7393).

Mini-Grassroots

Program of 45 minutes to 1½ hours, designed to aid components in programming. Gives overview of AIA services and benefits to members and augments local members with national staff. Can be combined with membership recruitment activities. Free.

Contact Component Services Office (626-7376).

For further information about membership procedures, contact the Membership Records Division, Office of Assistant Secretary, 626-7393. Questions pertaining to Honorary Membership (Hon. AIA) should be referred to Awards Division, Office of Assistant Secretary,

626-7390; to Honorary Fellowship (Hon. FAIA), Professional Interest Programs Office, 626-7364. More detailed biographical information on individual architects may be obtained through the Library, 626-7493.

For further information about securing new members, contact Local Component Affairs Office, 626-7378.

The Octagon

AIA Foundation Booklet

Booklet (1979) providing information on the AIA Foundation and the Octagon. Free.

Available through the Octagon, 1799 New York Ave. N.W., Washington, D.C. 20006 (638-3105).

AIA Headquarters Slide Show

Fifty color slides, with script and cassette tape (1974). Past AIA President Archibald Rogers, FAIA, discusses the AIA headquarters building and the Octagon. Free loan to AIA members only.

Available through Audiovisual Division, Library (626-7495).

The Octagon

Brochure containing a brief history of the Octagon, its hours of opening, etc. Free.

Available through Public Relations Department (626-7460).

The Octagon. Being an Account of a Famous Washington Residence: Its Great Years, Decline and Restoration.

History of the Octagon with index and selected bibliography. Prepared by George McCue, Hon. AIA. 61 illustrations, seven in full color. 106 pages; \$6, postpaid.

Send check to The Octagon, 1799 New York Ave. N.W., Washington, D.C. 20006 (638-3105).

Octagon Slide Set

Five color slides of the Octagon. \$2.

Available from the Octagon, 1799 New York Ave. N.W., Washington, D.C. 20006 (638-3105).

For further information about the Octagon, contact the Curator, 638-3105.

Office Management

The AIA Handbook (1-HBC1)

Chapter 1 (1973) of the Architect's Handbook of Professional Practice, this document includes general information on the Handbook, including the preface, table of contents, general index and information on chapters. \$.60/\$.90.

Available through Publications Fulfillment Office (626-7332).

Architect's Handbook of Professional Practice (1-M104)

Two-volume set in ring binders includes samples of all A, B, C, D, E and G documents, plus 18 chapters and a glossary of construction industry terms. \$23.50/\$35. Contents only (no binders), \$16.75/\$25. (1-M104A). Two binders (no contents), \$10/\$6.75 (1-M104B). Individual chapters of the Handbook are listed under AIA Documents, and described under the subjects they cover.

Available through Publications Fulfillment Office (626-7332).

Architect's Handbook of Professional Practice—Supplement Service (4-Z100)

Subscriptions to the Supplement Service bring the latest editions of the documents contained in the handbook to subscribers. \$12.

Available through Publications Fulfillment Office (626-7332).

The Architect's Office (1-HBC6)

Chapter 6 (1971) of the Architect's Handbook of Professional Practice. Document covers management planning, legal structure, financial management, organization, selection and direction of staff and the personnel policy manual. \$1.20/\$1.80.

Available through Publications Fulfillment Office (626-7332).

Architectural Secretaries Association

Organized to promote and advance the professional and educational standards of architectural secretaries and contribute to the improvement of administrative procedures in architectural offices, ASA has chapters, locally sponsored by AIA chapters, all across the country. ASA holds annual meetings in conjunction with the AIA national convention.

Contact Betsi Fassett, AIA/ASA Liaison (626-7387). For information on local chapter meetings, contact AIA chapter nearest you.

Current Techniques in Architectural Practice (2-M701)

An overview of the practice of architecture edited by Robert A. Class, AIA, and Robert E. Koehler, Hon. AIA. Published jointly by AIA and Architectural Record Books. 275 pages; \$22/\$27.50.

Available through Publications Fulfillment Office (626-7332).

Design Disciplines: An Overview of Office Practice

A series of seminars produced and sponsored by the Architectural Secretaries Association to introduce the new architectural secretary and/or recent architect-

Of

tural graduate to the administrative functions of an architectural practice. Contact Betsi Fassett, AIA/ASA Liaison (626-7387).

Developing Your A-E Firm for Greater Personal, Professional and Financial Profit: A Self-Help Guide (4-ST101)

Provides a practical in-house development program for architectural firms. Covers such areas as: decision making, motivation and firm climate, setting and realizing goals, influence process, interpersonal perceptions and communication, leadership and client relations. \$15.

Available through Publications Fulfillment Office (626-7332).

Hertz Car Rentals Discount Card

Hertz identification card entitles AIA members, employees and families to a 25 percent discount off the advertised price of any Hertz rental car (excluding tour/touring rates.)

Available through Controller's Office (626-7322).

Introduction to Basic Accounting and Reporting Systems for the Small Design Office—Architectural Secretaries Association Seminar

The first in-depth program taken from the overview of office practice seminars. It is a study of organization types, record and bookkeeping systems for the small firm, taxation and pension-profit sharing plans. This packet includes all of the necessary information for conducting the program locally.

Contact Betsi Fassett, ASA/AIA Liaison 6626-7387).

The Management of Time (3-S216)

Cassette explaining how to accomplish more in less time. A guide to organize and use time efficiently and effectively. 45 minutes. \$9/\$10.

Available through Publications Fulfillment Office (626-7332).

Setting Up an Architectural Firm (3-S229)

Cassette covering the wide range of considerations in setting and running an architectural firm, including organization, business management, legal considerations, information resources, office machines. 90 minutes. \$9/\$10.

Available through Publications Fulfillment Office (626-7332).

Uniform Construction Index: A System of Formats for Specifications, Data Filing, Cost Analysis and Project Filing (2-M200)

A comprehensive data filing format (1972) for design and construction information; a format for filing project correspondence; the CSI format for construction specifications; an estimator's cost analysis format,

and a key word index interrelated with the specifications and data filing formats. \$9.60/\$12.

Available through Publications Fulfillment Office (626-7332).

Periodicals

ACSA News

Newsletter issued seven times during the academic year, containing news about architectural schools. Available only by membership. Price: \$14 for students; \$23 for all others. Membership includes "Journal of Architectural Education."

Available through Association of Collegiate Schools of Architecture at AIA (785-2324).

AIA Journal

Official magazine of AIA, published 14 times a year. Subscription price included in AIA membership dues.

For subscription information for others, contact Circulation Department, AIA Journal (626-7327).

AIA Memo

Newsletter, published twice a month, sent to the entire membership. Aims to keep members abreast of Institute programs, achievements, services, etc. Free.

Available through Public Relations Department (626-7460).

ASA Journal

Official publication of the Architectural Secretaries Association. Published three times yearly to provide communication between ASA chapters and articles of interest to the membership.

Contact Betsi Fassett, AIA/ASA Liaison (626-7387).

ASC/AIA News

Monthly newsletter of the Association of Student Chapters/AIA with news items of interest to architectural students. Free to ASC/AIA members and CRIT/ASJ subscribers.

Available through Association of Student Chapters/AIA, at AIA Headquarters (626-7472).

CRIT—The Architectural Student Journal

Biannual magazine published by the Association of Student Chapters/AIA. Includes articles on architecture, architectural education and alternative careers in architecture. Free to ASC/AIA members. Two-year subscription is \$4.

Available through Association of Student Chapters/AIA at AIA Headquarters (626-7472).

Government Alert for Components

Bulletin published six times a year containing brief, timely reports on govern-

ment affairs developments at the state and local level. Free.

Available through State and Local Government Programs Office (626-7386). InBrief (4-Z300-2)

Monthly magazine featuring concise abstracts of articles selected from over 75 architectural, engineering and business periodicals. One year subscription \$60; two-year subscription \$100.

Contact Publications Marketing Office (626-7474).

Journal of Architectural Education

Quarterly (during academic year) journal of the Association of Collegiate Schools of Architecture (ACSA). Single issue \$4; free to ACSA members; \$12 per year without membership to all others.

Available through Association of Collegiate Schools of Architecture, at AIA Headquarters (785-2324).

Public Relations Letter (PRL)

Bimonthly newsletter giving case studies of component programs, national PR, announcements of program packages, "how-to" tips, etc. Especially useful for chapter PR chairmen. 18 issues and index. Free.

Available through Public Relations Department (626-7460).

Research and Design

Published four times a year by the AIA Research Corporation, and mailed free of charge to architectural libraries, deans of professional schools of architecture and to the professional architectural firms and architects working in government and industry who are listed as members of AIA. Additional subscriptions are available for \$15 in the U.S. (and possessions) and Canada, and for \$30 elsewhere. Single copies are available for \$4. All payments must be received in advance.

Available through AIA Research Corporation (626-7500).

Posters

Architectural Styles Chart

American architecture examples, 1600 to 1940. 40x30 inches, prepared by Panek. \$8 postpaid.

Available through St. Louis Chapter/AIA, 919 Olive St., St. Louis, Mo. 63101

Charles Eames Memorial Poster

Large photo (20x16½ inches) of Charles Eames smiling warmly and pensively. \$.50 plus tax and postage.

Available through Los Angeles Chapter/AIA, 8687 Melrose Ave., Los Angeles, Calif. 90069, (213) 659-2282.

Historic Rosson House

Poster of Rosson House, Phoenix, Ariz., drawn by Frederick Schweitzer, AIA; black on ivory, 18x24 inches. \$5 postpaid.

Available through *Arizona Architects Foundation, Inc.*, 1121 N. Second St., Phoenix, Ariz. 85004

Restoring a Landmark

Poster showing cross section of the Octagon, plate XII from Glenn Brown's 1914 monograph. 24x32 inches. \$4.50 postpaid.

Available through *the Octagon, 1799 New York Ave. N.W.*, Washington, D.C. 20006 (638-3105).

St. Louis—Montage of St. Louis**Buildings**

Black and white print (20x14 inches or 26x18 inches) suitable for framing. \$7 postpaid. Specify large or small size.

Available through *St. Louis Chapter/AIA*, 919 Olive St., St. Louis, Mo. 63101.

St. Louis World's Fair Panorama Poster

Shows buildings and plan of 1904 fair. 36x14 inches. \$8 postpaid.

Available through *St. Louis Chapter/AIA*, 919 Olive St., St. Louis, Mo. 63101.

Wind Energy Poster (4-M233)

Front side illustrates the history of wind-harnessing devices for mechanical and electrical power from pre-Christian times to the present. Back side gives an account of technical design information for modern wind energy conversion systems, and a list of manufacturers, research organizations and literature references. Includes a summary in French and German. Developed by Vonier and Wolff. Four-color, 24x30 inches. Single copy \$4, two or more (4-M233Q) \$3.25 each.

Available through *Publications Fulfillment Office (626-7332)*.

Practice

The AIA Handbook (1-HBC1)

Chapter 1 (1973) of the Architect's Handbook of Professional Practice, this document includes general information on the Handbook, including the preface, table of contents, general index and information on chapter. \$.60/\$.90.

Available through *Publications Fulfillment Office (626-7332)*.

Architect's Handbook of Professional Practice (1-M104)

Two-volume set in ring binders includes

samples of all A, B, C, D, E and G documents, plus 18 chapters and a glossary of construction industry terms. \$35/\$23.50. Contents only (no binders), \$25/\$16.75 (1-M104A). Two binders (no contents), \$10/\$6.75 (1-M104B). Individual chapters of the Handbook are listed under **AIA Documents**, and described under the subjects they cover.

Available through *Publications Fulfillment Office (626-7332)*.

Architect's Handbook of Professional Practice — Supplement Service (4-Z100)

Subscriptions to the Supplement Service bring the latest editions of the documents contained in the handbook to subscribers. \$12.

Available through *Publications Fulfillment Office (626-7332)*.

Current Techniques in Architectural Practice (2-M701)

Book (1976) edited by Robert Allan Class, AIA, and Robert E. Koehler, Hon. AIA. An overview of architectural practice, with emphasis on management, plus a comprehensive, annotated bibliography. Published jointly by AIA and Architectural Record Books. 275 pages; \$22/\$27.50.

Available through *Publications Fulfillment Office (626-7332)*.

Introduction to Basic Accounting and Reporting Systems for the Small Design Office—Architectural Secretaries Association Seminar

The first in-depth program taken from the overview of office practice seminars. It is a study of organization types, record and bookkeeping systems for the small firm, taxation and pension-profit sharing plans. Packet includes all necessary information for conducting the program locally.

Contact *Betsi Fassett, ASA/AIA Liaison (626-7387)*.

Project Checklist (1-D200)

Thirty-page publication (1973) provides a complete checklist of tasks necessary to design and administer the construction of a building project. Guide should be used as a project record on every project. \$1.20/\$1.80.

Available through *Publications Fulfillment Office (626-7332)*.

Project Delivery Approaches: An AIA Guide (2-M702)

Primer (1976) edited by David S. Haviland of the AIA project management systems task force and planned as the nucleus and framework for AIA development of a series of studies and guidelines for responsive and creative project delivery approaches. 30 pages; \$3.25/\$4. Available through *Publications Fulfillment Office (626-7332)*.

Project Procedures (1-HBC11)

Chapter 11 (1969) of the Architect's Handbook of Professional Practice, this document outlines architect and owner responsibilities, organizing the project, instructions for the job captain, scheduling project services, project program, schematic design, design development, construction documents and construction, cost of rendering service and the project record book. \$1.20/\$1.80.

Available through *Publications Fulfillment Office (626-7332)*.

Survey of Southern California Housing (Environmental Communications)

One-hundred color slides with booklet. Illustrates the great variety of housing, including mansions in Beverly Hills, "cliff-hangers" in Hollywood, the ghetto in Watts, beach places in Malibu and apartment buildings and housing throughout the area. Rent \$15 to AIA members only.

Available through *Audiovisual Division, Library (626-7495)*.

For further information about contract forms, liability and the use of the Architect's Handbook of Professional Practice, contact the *Documents Office, 626-7454*. For other specific questions relating to architectural practice, contact the *Practice Office, 626-7457*.

Presentation Techniques

Conducting Winning Presentations (4-T105)

Eight-step correspondence course dealing with techniques of conducting presentations, client reaction to presentations and post-presentation follow-through. \$95 for the first person; \$25 for each additional person (4-T105A).

Available through *Professional Development Office (626-7355)*.

Professional Interest Programs

Corresponding Committee Membership

Corresponding committee membership is available to all AIA members. Memberships are for the calendar year. Corresponding committee members receive all notices, meeting minutes and reports of the committee; participate in committee

meetings and activities to the degree desired, and contribute to committee tasks and deliberations as they wish. The committees with corresponding membership are:

architects in industry
commerce and industry
education
health
justice
art and recreation
historic resources
housing
interior architecture

Contact Professional Interest Programs Office (626-7365).

Professional Interest Programs/Seminars
Annual seminars bring together architects with similar professional interests. Interchange provides architects with resources to improve the quality of design and professional services for the client. Seminars planned for fall 1980 are:

Interior architecture, Oct 2-3, New York City;
Housing, Oct. 5-8, Washington, D.C.;
Architects in industry, Oct. 12-15, Williamsburg, Va.;
Justice, Oct. 30-Nov. 1, Gainesville, Fla.
Contact Professional Interest Programs Office (626-7365).

Programming

The Architect's Guide to Facility Programming (2-M726)

A thorough examination of contemporary programming in architecture, including role, process, techniques, tools, applications (via case studies) and opportunities. \$34.95 tentative price.

Available in 1981 through Publications Fulfillment Office (626-7332).

Emerging Techniques 2—Architectural Programming (2-M201)

Book (1968) by Benjamin H. Evans, AIA, and C. Herbert Wheeler Jr., FAIA, describing the means through which data about the needs of the ultimate building user are determined and expressed from the instruction of the architect to the design solution. 68 pages; \$5/\$6.

Available through Publications Fulfillment Office (626-7332).

For further information about programming in general, contact the Practice Office, 626-7457.

Project Delivery

The Architect's Guide to Facility Programming (2-M726)

A thorough examination of contemporary programming in architecture, including role, process, techniques, tools, applications (via case studies) and opportunities. \$34.95 tentative price.

Available in 1981 through Publications Fulfillment Office (626-7332).

Design/Build/Bid (2-M199)

Report (1975) of the AIA design-build-task force appointed in early 1973.

Includes *Design/Build/Bid: An Owner's Guide*. 36 pages; \$3/\$3.50.

Available through Publications Fulfillment Office (626-7332).

Design/Build/Bid: An Owner's Guide (6-N903)

Booklet (1975) to assist a potential public sector client in evaluation of the design-build-bid process. Free.

Available through Publications Fulfillment Office (626-7332).

Development Building: The Team Approach (2-M135)

Guide to project development (1972) by C. W. Griffin. Published by AIA. 130 pages; \$16/\$20.

Available through Publications Fulfillment Office (626-7332).

Emerging Techniques 2—Architectural Programming (2-M201)

Book (1968) by Benjamin H. Evans, AIA, and C. Herbert Wheeler, Jr., FAIA, that describes the means through which data about the needs of the ultimate building user are determined and expressed from the instruction of the architect to the design solution. 68 pages; \$5/\$6.

Available through Publications Fulfillment Office (626-7332).

Professional Construction Management and Project Administration (3-M121)

Book (second edition, 1976) by William B. Foxhall looks at new professional services and who provides them. Published jointly by AIA and *Architectural Record*. 125 pages; \$20.25/\$22.50.

Available through Publications Fulfillment Office (626-7332).

Project Delivery Approaches:

An AIA Guide (2-M702)

Publication (1976) edited by David S. Haviland of the AIA project management systems task force, guide is essentially a primer planned as the nucleus and framework for AIA series of studies and guidelines for responsive and creative project delivery approaches. 30 pages; \$4/\$3.25.

Available through Publications Fulfillment Office (626-7332).

Public Buildings

Forum on Public Architecture: A Conference for Government Administrators—A Resource Book

Collection of articles (1976) on public architecture, presenting significant state and local activity in such areas as energy conservation, land use and adaptive use. 142 pages; free.

Available through State and Local Government Programs Office (626-7386).

For further information about public buildings in general, contact either the Federal Agency Liaison Office, 626-7382, or State and Local Government Programs Office, 626-7386.

Public Relations

Adaptive Re-Use: Extending the Life of Old Buildings (6-N827)

Using recent AIA Honor Award winning buildings as examples, this pamphlet describes the growing trend in architecture which advocates the adaptive re-use of older structures to give them new life in the modern world. Examples include Boston's Faneuil Hall, San Francisco's Cannery and Ghirardelli Square and Chicago's Navy Pier. Free.

Available through Publications Fulfillment Office (626-7332) or Public Relations Department (626-7460).

The AIA Asks: Why? Why Not?:

Program Package 1 (6-N807)

Explains how to place a series of pictures and captions about good and bad environmental features in local newspapers.

Describes the program, gives ideas for pictures and captions, provides "how-to" information about approaching the newspaper, etc. 25 pages (1974); free.

Available through Publications Fulfillment Office (626-7332) or Public Relations Department (626-7460).

AIA Emblem for Printing

Instruction sheet regarding rules for use of AIA emblem. Two sheets of reproducible emblems in various sizes for use on letterheads, etc. Free. Limited quantities.

Available through Public Relations Department (626-7460).

AIA Memo

Newsletter, published twice a month, sent to the entire membership. Aims to keep members abreast of Institute programs, achievements, services, etc. Free.

Available through Public Relations Department (626-7460).

American Institute of Architects Advertising

Leaflet describing former national advertising campaigns, ads for local use. Includes public service radio and television spots. Free.

Available through Public Relations Department (626-7460).

Architects Bite!

Flyer (1980) written for a general audience and designed for distribution by components at home shows, etc., to promote client awareness. Consists of a series of common myths about architects which are disproved through case studies illustrating successful architect/client relationships. \$5/100 copies.

Available through Public Relations Department (626-7460) or Publications Fulfillment Office (626-7332).

Building a Better Environment

"Clip sheet" (1973) of news features with illustrations stressing value of AIA national policy task force recommendations for improving communities. Reproducible articles for newspapers. Free.

Available through Public Relations Department (626-7460).

Built Environment Education: Program Package 10 (6-N824)

Folder highlighting a built environment education program for elementary school students developed and implemented by an architect. Includes a step-by-step sample program outline, plus a guide to resources and information on built environment education. Free.

Available through Publications Fulfillment Office (626-7332) or Public Relations Department (626-7460).

Celebrating American Architecture (4-N825)

Set of 80 slides depicting 1979 national honor award and 25-year award winning buildings. Script is included to provide brief descriptions of the structures. \$18 prepaid.

Available through Publications Fulfillment Office (626-7332).

Celebrating Excellence: Program Package 11 (6-N829)

A "how-to" guide that addresses AIA components interested in setting up successful awards programs. With documented examples from Florida Association/AIA, Houston Chapter/AIA and other components' efforts, this package provides useful, basic information and guidelines for each step of the program. An insert of the AIA Board Guidelines for Component Awards Programs is included. Free to components.

Available through Publications Fulfillment Office (626-7332) or Public Relations Department (626-7460).

A Celebration of Architecture (6-N826)

Flyer describing AIA's 1979 celebration program in which architects throughout the country encourage greater public understanding of what architecture is, how it can be enjoyed and how it comes to be.

Free.

Available through Publications Fulfillment Office (626-7332).

A Celebration of Architecture: 25 Ideas for Components

Slide show and script which briefly describe 25 ways for AIA components to focus the public's attention on the built environment. The show outlines projects used to implement AIA's 1979 Celebration of Architecture program—tours, exhibits, guidebooks, etc. An "idea-kit" for components looking for PR projects to undertake. Free loan to components.

Available through Publications Fulfillment Office (626-7332).

Component Editors Critique Service

A program to help improve the skills of editors of component newsletters and magazines. Written critiques by graphic and editorial consultants are available on request.

Contact Public Relations Department (626-7459).

Component PR Assistance/Counseling

A program which offers different kinds of PR information, program packages, counseling and other aids to help components solve individual PR problems.

Contact Public Relations Department (626-7459).

Conversation with an Architect

Two-page flyer describing theme and subject matter of 1975 film by same title. Free.

Available through Public Relations Department (626-7460).

Designing Your Brochure as an Aid in Marketing Your Services (3-S224)

One-hour cassette (1976) tells how to gear your brochure to your desired market by making it convey your firm's personality, your ability to take care of the client, your problem-solving ability, the range of your services, etc. The contents of an "ideal" brochure are outlined. \$9/\$10.

Available through Publications Fulfillment Office (626-7332).

Effective Public Relations: A Guide for AIA Components (4-N805)

Annual loose-leaf "how to" handbook on PR planning, press relations, newsletters, speeches, television, etc. Free to chapter executives and PR chairmen; \$5 to others. *Available through Publications Fulfillment Office (626-7332).*

Environments for People: Program Package 5 (4-N812)

Eighty slides, introduction, script and suggestions for use (1976). Explains how architects provide for basic human needs (shelter, privacy, personalization, socializing, mobility, communication) in their design of the human environment. \$20 prepaid.

Available through Publications Fulfillment Office (626-7332) or Public Relations Department (626-7460).

Hold on to Your Heat (and Keep Your Cool) (6-N906)

Pamphlet (1976) intended as a homeowner's guide to energy conservation. Describes how to take advantage of site, envelope, floor plan, windows, insulation, etc., to conserve energy. Includes bibliography. Free.

Available through Publications Fulfillment Office (626-7332).

Houston Architecture April Festival: Program Package 7 (6-N831)

A folder (1976) explaining how the Houston Chapter/AIA held a month-long festival to increase public awareness and appreciation of architecture and architects. Includes descriptions of individual events, their planning, cost and publicity. Illustrated with news clips about the festival and samples of poster, tickets and map graphics used by the chapter. Free.

Available through Publications Fulfillment Office (626-7332) or Public Relations Department (626-7460).

How Architecture Speaks: Program Package 2 (4-N808)

Forty-three slides, guidelines, script and quiz sheets (1974) that show people how architecture "speaks" through form, color, scale, texture, materials. Quiz tests people's reactions to structures. \$18 prepaid.

Available through Publications Fulfillment Office (626-7332) or Public Relations Department (626-7460).

Indianapolis Architecture Guidebook: Program Package 8 (6-N832)

Folder (1977) describing the process by which Indianapolis Chapter/AIA published an extensive guidebook of that city. Includes sections on why to write a guidebook, forming a committee, fund-raising, budgeting, selecting printer and designer and publicizing the project and the product. Free.

Available through Publications Fulfillment Office (626-7332) or Public Relations Department (626-7460).

News Clipping Clearinghouse 1977

Two collections of news clippings to aid the component in dealing with local newspapers. The first collection explains "How You Can Get Publicity Through AIA Participation in Public Affairs." News clips illustrate successful public affairs projects undertaken by components.

These clips show what makes news; gives ideas for programs to generate publicity. The second collection gives "Suggestions on Placing Articles in Your Local Paper," through samples of published articles written by AIA members. These clips may be used as guides for submitting articles to local papers. Free.

Available through Public Relations Office (626-7460).

No Little Plans

The history of AIA and its services today, featuring Elmer Botsai, FAIA; Wolf von Eckardt, Hon. AIA, and Winfield Rankin, Hon. AIA; includes material drawn from the AIA archives and library. 16mm color slide-film, 18 minutes. Free loan to AIA components and chapters. *Available through Audiovisual Division, Library (626-7495).*

Nobody Wants to Listen to Your Problems — Right? Wrong (6-N814)

Companion pamphlet to 1975 ad series encouraging clients to "plan now." ("One of these days you're going to build . . ." "When you think it's too soon to call an architect . . ." and "There's a way to save on your next building.") Consists of case studies demonstrating advantages of hiring an architect for planning although construction time is indefinite. Free.

Available through Public Relations Department (626-7460).

Orchids and Onions: Program Package 4 (6-N811)

Folder (1975) explaining how components can carry on a program which asks the public to nominate organizations and individuals who make good or bad contributions to the man-made environment; a jury selects the winners. Based on a project of the Western Communities Architects' Association, a section of the Chicago Chapter/AIA. Free.

Available through Publications Fulfillment Office (626-7332) or Public Relations Department (626-7460).

The Octagon

Brochure containing a brief history of the Octagon, its hours of opening, etc. Free. *Available through Public Relations Department (626-7259).*

Prescriptive Standards: No Rx for Energy Conservation in Buildings (6-N816)

Folder (1976) promoting performance-oriented standards for energy conservation, rather than prescriptive standards. Free.

Available through Publications Fulfillment Office (626-7332).

Public Relations Letter (PRL)

Bimonthly newsletter gives case studies of component programs, national PR, announcements of program packages, "how-to" tips, etc. Especially useful for chapter PR chairmen. 18 issues and index. Free.

Available through Public Relations Department (626-7460).

Report of the Board

Annual Report of AIA. Free.

Available through Public Relations Department (626-7460).

Sample Articles for Components

A collection of sample articles to help AIA components encourage newspaper editors to run regular columns on architecture in local papers. Each article discusses a different aspect of architecture of interest to the public. Free to components.

Available from Public Relations Department (626-7460).

Saving Energy in the Built Environment: The AIA Policy (6-N904)

Brochure (1975) summarizing two previous publications: "Energy and the Built Environment: A Gap in Current Strategies"; "A Nation of Energy Efficient Buildings by 1990." Free.

Available through Publications Fulfillment Office (626-7332).

The Solar Advantage (6-N820)

Pamphlet (1978) briefly describing current studies and legislation concerning solar energy. Results of recent research are applied to the energy efficiency of residences. Free.

Available through Director, Energy Programs (626-7448).

Something This Good Can Last Forever

Three 30-second television spots (1975), stressing importance of land use planning and showing a variety of urban and rural scenes to demonstrate benefits of intelligent land use. One spot is on George Washington as surveyor. Free. AIA requires knowledge of stations using spots.

Available through Public Relations Department (626-7460).

What Architects Do

Public relations brochure covering topics such as selecting an architect, costs, functions and savings, making the most of the natural environment, how an architect can save you money, what construction involves and how to pay the architect. \$1.

Available through the Minnesota Society AIA, 314 Clifton Ave., Minneapolis, Minn. 55403, (612) 874-8771.

What Do They Have in Common? (4-N604)

Eighty slides of American architecture designed by women. Slides run gamut from solar homes to urban hospitals, from Manhattan to California. Package includes viewer handouts, guidelines for suggested use. Appropriate for career guidance, public awareness presentations, slides can be shown without narration. \$20.

Available through Publications Fulfillment Office (626-7332) or Public Relations Department (626-7460).

Women in Architecture: A Special Report

Eight-page special issue of the AIA Memo (January 1976) that describes the AIA's affirmative action plan to increase involvement of women in AIA and the profession. Free.

Available through Public Relations Department (626-7460).

You and Your Architect (4-N802)

A booklet answering client questions about the selection and compensation of an architect. Outlines the responsibilities of an architect, client and other members of the building team during design and construction. Revised in 1980. Up to 25 copies free to chapters; after that \$10 per 100.

Available through Publications Fulfillment Office (626-7332).

For further information about public relations in general, contact Public Relations Department, 626-7459.

Publications Sales

Publications Price List and Order Form (6-N702)

List of AIA documents and forms, books, manuals, audiovisual materials, etc., available for sale through AIA. Free.

Available through Publications Fulfillment Office (626-7332).

Publications Sales

AIA sells documents, books, audiovisual materials, etc., to architects, components and the public. Members and components are entitled to varying discounts depending on nature of the publications.

Contact Publications Marketing/Sales Office (626-7474).

For further information about publications which are sold and to place orders, contact the Publications Fulfillment Office, 626-7332.

Railroad Stations

Stations

Color film, 16mm, 28 minutes (1974). Shows many of the interesting and innovative uses being made of old railroad stations, in order to preserve these landmarks. Rent \$15 to AIA members only. Available through Audiovisual Division, Library (626-7495).

Real Estate

Land Development Game Seminar (4-T102)

Six-step correspondence course to teach how to do land development through actual experience. \$75 for the first person from a firm, \$15 for each additional person from the same firm (4-T102A). Available through Professional Development Office (626-7355).

Registration

License Renewal Legislation/Regulation: A Strategy Guide for AIA Components

Discusses the issue of license renewal for architects, outlines potential action by components and contains legislative and regulatory guidelines for components. 24 pages.

New License Renewal Requirements for Architects: The AIA's Policy and Initiatives

Presents AIA policy on license renewal, describes the principles of the professional development measuring system, and discusses current state activity on license renewal. Companion publications. 21 pages. Both free.

Both available through State Component Affairs Division (626-7386).

Sunset Laws: A Strategy Guide for AIA Components

How sunset reviews can affect architecture-related matters and strategies for effective participation in sunset reviews. 46 pages; free.

Available through State Component Affairs Office (626-7386).

Sunset Laws Review: Architect Registration Boards

Discusses the experiences of states that have recently had sunset reviews of the architect registration boards (May 1980). Free.

Available through State Component Affairs Office (626-7386).

For further information about registration of architects in general, contact the National Council of Architectural Registration Boards, at AIA Headquarters, 659-3996. For further information about registration laws, contact State Component Affairs Office, 626-7377.

Research

Library Research Services

The library staff will respond to questions, either in person, by telephone or by letter, on aspects of architecture and construction, architectural history, building types, etc., using the library's cataloged volumes, more than 400 current periodicals, reference books and indexes. Free.

Contact the Library (626-7493).

Research and Design

Published four times a year by the AIA Research Corporation, and mailed free of charge to architectural libraries, deans of professional schools of architecture and to the professional architectural firms and architects working in government and industry who are listed as members of AIA. Additional subscriptions are available for \$15 in the U.S. (and possessions) and Canada, and for \$30 elsewhere. Single copies are available for \$4. All payments must be received in advance. Available through AIA Research Corporation (626-7500).

Signs

Model Sign Control Ordinance

Fifteen-page guide (1965) prepared by the AIA commission on environment and design to help communities write sign control regulations. Free.

Available through Practice and Design Office (626-7359).

Specifications

Construction Documents—Specifications (1-HBC14)

Chapter 14 (1972) of the Architect's Handbook of Professional Practice, this document includes information on writing specifications, procedure, form, policy, method versus result, production and specification references. \$1.80/\$1.20.

Available through Publications Fulfillment Office (626-7332).

An Introduction to Masterspec 2

Slide show explaining the master specification system designed to help the architect remain competent and competitive.

Consists of a carousel tray of 85 slides and a 20-minute cassette tape. Free loan; available only for organized meetings and seminars.

Contact PSAE, a wholly owned corporation of AIA, at AIA headquarters (626-7550).

Masterspec 2—The Comprehensive Specification System

Twelve-page brochure, describing the Masterspec 2 system including details about the new stand-alone basic version, which is particularly relevant to small general practice firms. Further information and samples available. Free.

Contact PSAE, a wholly owned corporation of AIA, at AIA headquarters (626-7550).

Masterspec 2 Workshops

One-day continuing education course on Masterspec 2 consisting of lectures, hands-on exercises and a slide show of specification systemization theory and practice. Workshops are designed to enable design professionals to understand, evaluate and utilize master specification technology and the adaptable Masterspec 2 system and its primary stand-alone basic version. Masterspec 2 workshops are available to recognized organizations at PSAE's discretion, anywhere in the continental U.S. for a minimum of 25 preregistered attendees, on a first-come-first-served basis. Scheduling of a workshop requires a local sponsor to provide local promotion, space, lunch and coffee. Eight contact hours, 0.8 AIA CEU's.

Contact PSAE, a wholly owned corporation of AIA, at AIA headquarters (626-7550).

For further information about specifications in general, contact Production Systems for Architects and Engineers, Inc. (PSAE), at AIA Headquarters, 626-7550.

Transportation

For information about transportation planning in general, contact the Practice and Design Office, 626-7359.

Underground

Building Underground for People: Eleven Selected Projects in the United States (4-M711)

Report (1978) by Michael Barker, documenting a sampling of underground projects that involve human habitation in the U.S. Information includes descrip-

Ur

tion of each project, owner, design team, contractor, size, cost, date of completion and decision to build subsurface. 30 pages; \$6.

Available through Publications Fulfillment Office (626-7332).

Urban Planning

Blueprints for the Future

16mm color/sound film, 30 minutes (1965) that presents several master plans for Houston. A study of the architectural needs of the total city. Free loan.

Available through Houston Chapter/AIA, 3121 Buffalo Speedway, Suite 404, Houston, Tex. 77098, (713) 629-0191.

Building a Better Environment

"Clip Sheet" (1973) of news features with illustrations stressing value of AIA national policy task force recommendations for improving communities. Reproducible articles for newspapers. Free.

Available through Public Relations Department (626-7460).

Downtowns for People

Color 16mm film, 26 minutes (1972) showing examples of European and American downtown areas from the pedestrian's viewpoint. Free loan to AIA members only, no sale.

Available through Audiovisual Division, Library (626-7495).

Innovations in State Legislation: Land Use Management; Environment and Land-Use: Two California Experiments

Two publications (1973 and 1975) by Richard N. Tager, offered as one unit. The first is an overview of the role states can play in implementing the fundamental recommendations of the AIA national policy task force. The second report discusses the background and fundamental provisions of CEQA and the Coastal Zone Act.

Available through Design and Environment Programs Office (626-7363).

Lafayette R/UDAT

Color film, 16mm, 25 minutes (1978), documents the AIA R/UDAT visit to Lafayette, La. Free loan to AIA members. *Available through Audiovisual Division, Library (626-7495).*

Los Angeles: 20th Century American City (Environmental Communications)

Color slides with booklet. Explores important aspects of new trends and problems in contemporary urban development: urban

sprawl, low-density ghetto, freeway systems, leisure facilities land use patterns. Rent \$15 to AIA members only.

Available through Audiovisual Division, Library (626-7495).

R/UDAT Films

Films of some previous R/UDATs are available on loan.

Available through Audiovisual Division, Library (626-7495).

R/UDAT Program

Through the Regional/Urban Design Assistance Team Program, chapters can arrange for a team of AIA members and other specialists to visit their communities and advise them on specific community planning and urban design problems or on long-range goals in regional planning.

Contact Design and Environment Programs Office (626-7363).

R/UDAT: Regional/Urban Design Assistance Teams: A Program of The American Institute of Architects (6-N405)

Pamphlet (1976), addressed to community leaders, describing the R/UDAT program. Prepared by the AIA urban planning and design committee. Free. *Available through Publications Fulfillment Office (626-7332).*

R/UDAT Report on Forest Park, St. Louis

Facts and proposals (1976) for this green area established following the 1904 St. Louis World's Fair. \$13 postpaid. *Available through St. Louis Chapter/AIA, 919 Olive St., St. Louis, Mo. 63101, (314) 621-3484.*

R/UDAT Reports

Reports of recent R/UDAT visits available upon request. \$3-\$5. *Available through Design and Environment Programs Office (626-7363).*

The Santa Monica Mountains: A Possibility and Paradigm/Ventura Boulevard Study (L.A. Architect, January 1978)

These two reports are the work of chapter committees concerned with the development and use of these two important environmental areas in Los Angeles. Photographs and charts are accompanied by analyses and proposals. \$1 plus tax and postage.

Available through Los Angeles Chapter/AIA, 8687 Melrose Ave., Los Angeles, Calif. 90069, (213) 659-2282.

What is Regionalism?

AIA JOURNAL reprint on regional planning and development. Free. *Available through Design and Environment Programs Office (626-7363).*

Wilson R/UDAT

Color film, 16mm, 25 minutes (1974). Documents the AIA Regional/Urban

Design Assistance Team visit to Wilson, N.C. Free loan to AIA members only. *Available through Audiovisual Division, Library (626-7495).*

For further information about urban planning in general, contact the Design and Environment Programs Office, 626-7363.

Women in Architecture

The Status of Women in Architecture

Report (1975) of the AIA task force on women in architecture, which identifies several major areas where women have been either discriminated against or under-represented in the architectural profession and AIA. 38 pages; free.

Available through Component Services Office (626-7376).

What Do They Have in Common?

Program Package 9 (4-N604)

Slide show of contemporary American architecture designed by women. Included are informational handouts and guidelines for suggested use. The 80 slides run the gamut from solar homes to urban hospitals, from Manhattan to California. Can be shown without narration. \$20.

Available through Public Relations Department (626-7460) or Publications Fulfillment Office (626-7332).

Women in Architecture: A Special Report

Eight-page issue of the AIA Memo (January 1976) that describes the AIA's affirmative action plan to increase involvement of women in AIA and the profession. Free.

Available through Public Relations Department (626-7460).

For further information about women in architecture, contact the Coordinator, Women in Architecture, 626-7376.

Working Drawings

Construction Documents—Drawings (1-HBC12)

Chapter 12 (1970) of the Architect's Handbook of Professional Practice, this document includes general comments on drawings, instructions on laying out the work, production and ownership. \$.90/\$.60.

Available through Publications Fulfillment Office (626-7332).

dawn of a new vinyl wallcovering

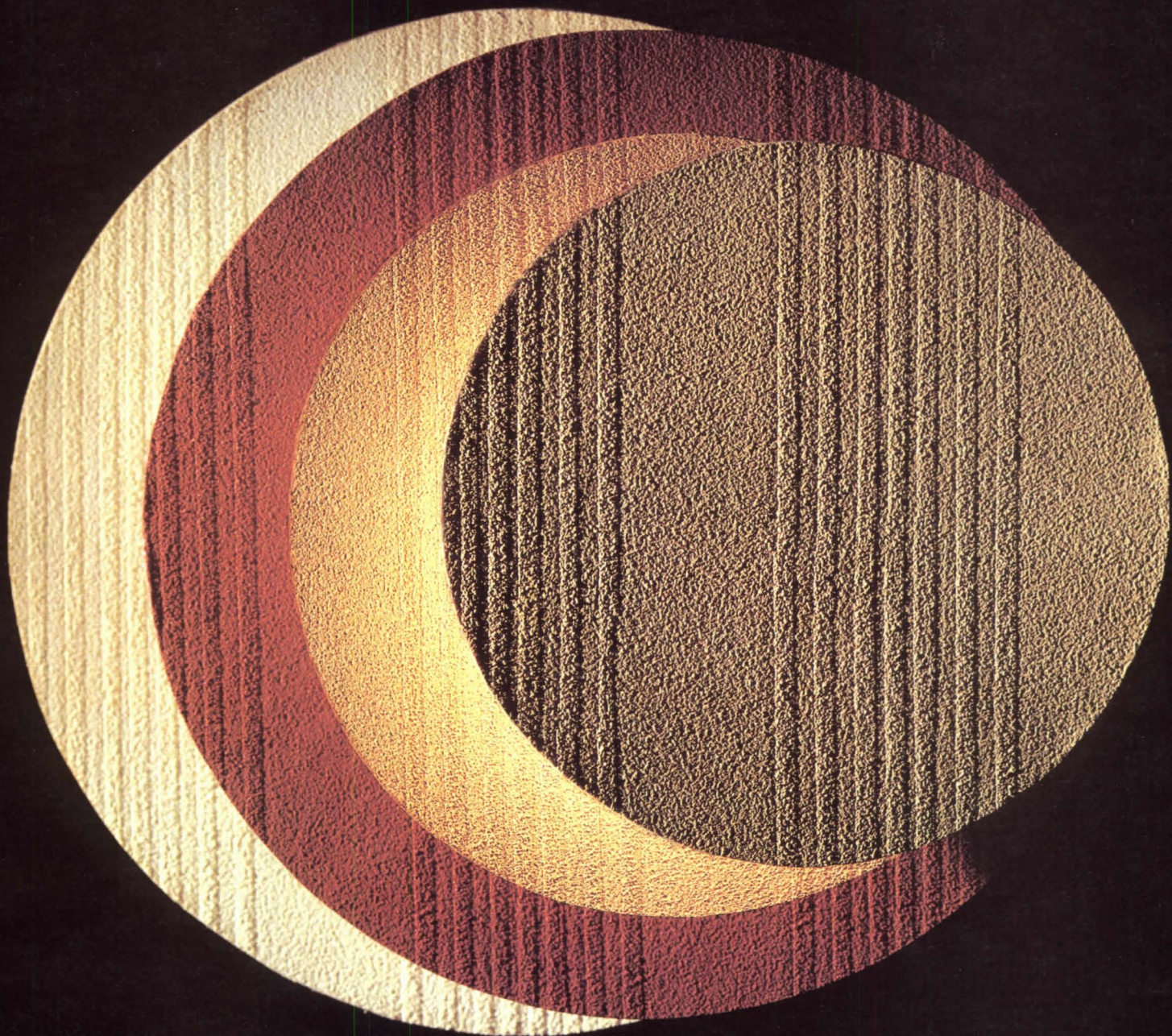

LUGANO
by VICRTEX®

L.E. CARPENTER and Company  A Dayco Company, 170 North Main Street, Wharton, N.J. 07885, (201) 366-2020/NYC (212) 751-3565
DISTRIBUTED BY: VICRTEX SALES DIVISION, New York, Atlanta, Chicago, Dallas, Los Angeles, San Francisco, Boston,
Minneapolis, Toronto, Montreal. HOWELLS, INC., Salt Lake City/PAUL RASMUSSEN, INC., Honolulu

Circle 46 on information card

These publications may be ordered from the AIA Department of Publications Marketing/Sales, 1735 New York Ave. N.W., Washington, D.C. 20006, (202) 626-7475. Include name of person to receive order, quantity, title, catalog number(s) and payment (check payable to AIA). *Indicates books published by organizations other than AIA and may not be in accord with AIA policy. The cost of each book is indicated as AIA members' price/nonmembers' price.

A

***Affordable Houses Designed by Architects** (3M420)

160-page book (1979) by the editors of *Architectural Record* offers an array of houses custom-designed by architects and built at developer prices. There are cost-saving hints on: building economically, using odd and inexpensive sites, using industrial materials in residential structures, making small spaces appear large and many more. \$18/\$19.95.

AIA Building Construction Legal Citator, 1980 Edition (2M119)

Compiled under the direction of Spencer, Whalen & Graham of the D.C. bar, this updated edition has been improved for easy reference and to speed research.

Volume 2 of the two-volume set contains the current edition plus all earlier editions of each form, reproduced in their entirety. Volume 1 of the set contains comprehensive, accurate and authoritative information on court decisions in all U.S. jurisdictions relating to the standard contract forms of AIA, and a complete cross-reference of the forms in volume 2. Two-volume loose-leaf binders. \$64/\$80.

***AIA Guide to New York City** (3M383) 653-page, revised edition (1978) by Norval White, FAIA, and Elliot Willensky, AIA, includes a short introduction and a capsule description of each of the five boroughs. Comments on shops, restaurants, theaters, parks, squares and buildings of historical and architectural interest. Paperback, \$9/\$9.95.

***AIA Guide to the Architecture of Washington, D.C.** (3M269)

Revised edition (1974) of the convention guidebook prepared by the Washington Metropolitan Chapter/AIA. The 246-page working guide is arranged into convenient walking and motoring tours. Paperback, \$6.25/\$6.95.

AIA Membership Directory (4M136)

Annual alphabetical listing of all AIA members and associates, including addresses and chapter affiliations. Appendices include honorary members and fellows, component presidents, medals and awards, affiliated and associated organizations. \$10/\$60.

***AIA Metric Building and Construction Guide** (3M426)

Edited for AIA by Susan Braybrooke, the 154-page primer (1980) provides information on the International System of Measurement (SI) as applied to building construction. Includes detailed drawings, charts, conversion tables and conversion factors. \$17.75/\$19.50. Paperback, \$13.25/\$14.50.

AIA Tote Bag (4M419)

American Institute of Architects in bold black letters with AIA emblem on off-white heavy-duty washable canvas bag. Size: 9½ x 13½ x 4½. \$6.

***Alternative Natural Energy Sources in Building Design** (3M323)

Alternative energy solutions to many energy design problems are discussed in this 215-page book (1977) by Albert Davis and Robert Schubert—through diagrams, tables and formulas. Paperback, \$7.25/\$7.95.

***American Country: A Style and Source Book** (3M460)

A comprehensive 292-page guide (1980) to the new trend in interior design that combines the finest objects of the American past with the casual style of today, written by Mary Ellisor Emmerling. A 40-page nationwide directory lists the antiques dealers who specialize in country furniture and art, the best museum collections and sources for contemporary furniture, housewares and accessories. \$27/\$30.

***The American Courthouse** (3M187)

The final product of a study cosponsored by AIA and the American Bar Association, this 320-page book (1972) presents an interdisciplinary view of the design of court facilities. \$36/\$40.

American Endless Weekend (2M151)

64-page publication (1973) by C. Ray Smith, AIA, that looks into recreation problems and planning in America. Prepared for the AIA committee on architecture for the arts and recreation. \$4.80/\$6.

***American Interiors: Architectural Digest Presents a Decade of Imaginative Residential Design** (3M325)

Paige Rense edited this 287-page book (1978). Some distinguished interiors of our time are shown through photo-

graphs and deft word pictures. \$31.50/\$35.

***Anatomy of a Park: The Essentials of Recreation Area Planning and Design** (3M126)

192-page "nontechnical" technical book (1971) by Albert J. Rutledge, presenting a system for evaluating the worth of a park design plan and a view of design criteria based upon behavioral science findings relating to people's needs—both esthetic and functional. \$24/\$26.50.

***Ancient Architecture** (3M179)

415-page book (1974) by Seton Lloyd and others. Volume 4 of the History of World Architecture series. \$40.50/\$45.

The Annual of American Architecture, 1980 (2M725)

Available for the first time in hardcover, this 120-page annual survey (1980) features significant architecture in America in 1979. Taken directly from the editorial portion of the 1980 Mid-May issue of the AIA JOURNAL, it includes such structures as homes, factories, churches, etc. \$16/\$19.95.

***Apprentice to Genius: Years with Frank Lloyd Wright** (3M397)

256-page book (1979) by Edgar Tafel, AIA, gives an insider's view of the genius who created a new school considered by many as the basis of modern architecture. Includes a list of the Wright buildings open to the public. \$19.75/\$21.95.

***The Architect as Developer** (3M235)

202-page book (1976) by John Portman, FAIA, and Jonathan Barnett, AIA, examines architectural and financial advantages of integrating real estate development and architectural design into a single process. Includes case study of Peachtree Center Plaza Hotel from conception to completion. \$27/\$29.95.

Architect/Engineer Government Contracting: A Manual (4M718)

In loose-leaf format, this convenient, easy-to-read manual (1979) contains actual forms, documents, regulations, laws, guidelines and techniques used by public officials and design practitioners in A/E contracting. Prepared by the Committee on Federal Procurement of A/E Services, it is available for the first time outside the successful contracting course. \$95.

Architect's Guide to Facility Programming (2M726)

Scheduled for publication in January 1981, this book by Mickey Palmer examines contemporary programming in architecture, including the architect's role, the process, techniques, tools, applications

(via case studies) and opportunities.

Tentative price: \$28/\$34.95.

Architect's Guide to International Practice (2M715)

107-page-guide (1978) contains pertinent facts on 29 foreign countries, acquainting architects with the complexities and legal/financial considerations for practicing abroad as well as the differences between foreign and domestic markets. Presents a general overview of international practice. \$16/\$20.

Architect's Handbook of Professional Practice (1M104)

Two-volume set in ring binders includes samples of all A, B, C, D, E and G documents, plus 18 chapters and a glossary of construction industry terms. \$23.50/\$35.

Architects in Government Roster (2M161)

List (1980) giving names and addresses of 2,300 architects employed by federal, state and local governments. \$4.80/\$6.

***Architectural Delineation: A Photographic Approach to Presentation** (3M128)

How the camera can be utilized in architectural and design presentation is the subject of this extensively illustrated 298-page book (1971) by Ernest Burden. It describes the various ways of preparing a layout for use with a camera, plus the techniques of drawing for final presentations. \$29.25/\$32.50.

***Architectural Graphic Standards** (3M103)

695-page book (6th edition, 1970) by AIA and the late C. G. Ramsey and H. R. Sleeper. A source book and standards guide for sizes, dimensions and details for all building materials and equipment. \$58.50/\$65.

***Architectural Illustration: The Value Delineation Process** (3M404)

256-page book (1979) by Paul Stevenson Oles, AIA, describes the best communication modes to use, presented from the architect's point of view. Models, computer graphics, design drawing representations and their advantages and disadvantages are covered in depth. The system presented here is useful for architects in terms of flexibility, applicability and quality of finished product. \$31.25/\$34.50.

***Architectural Photography** (3M238)

164-page book (1976) by Joseph Molitor shows how the architectural photographer

must understand composition, perspective, scale and mass, and relate each to building physical structure. 217 black and white and 31 color photographs explain each step in detail. \$27/\$29.95.

***Architectural Registration Handbook** (3M155)

Annual guide (1980) prepared by the National Council of Architectural Registration Boards for those taking Section B of the professional examination for architectural registration. Section A is covered by NCARB Design Test Handbook (3M427), listed separately. \$22.50/\$25.

***Architectural Rendering, Second Edition** (3M147)

336-page book (1973), by Albert O. Halse, includes information on techniques and media. Many chapters have been updated to include material on purchasing supplies, using various mediums and a close analysis of student renderings. \$36/\$39.95.

***Architectural Schools in North America** (3M124)

Edited by Roger Schluntz, AIA, and Sarah V. Weaver, this 271-page book (1978) contains the official architectural program descriptions of the 99 member schools and the 20 affiliate schools of the Association of Collegiate Schools of Architecture, located throughout the U.S. and Canada. \$8.25/\$8.95.

Architectural Secretaries Handbook (4M131)

Loose-leaf volume contains information on the Architectural Secretaries Association, the secretary and the office, the secretary and the project, reference materials and glossaries. Temporarily out-of-print.

Architectural Secretaries Handbook Supplement, 1978 (4M131-1)

Updated information for 1975 edition only of ASA Handbook. Material is included with 1978 edition of handbook. \$3.50.

***Architectural Signing and Graphics** (3M387)

Written by John Follis and Dave Hammer, this 232-page book (1979) provides detailed practical information on the signing and graphics requirements of a variety of projects and outlines business procedures and practices involved in the design solution. \$29.25/\$32.50.

***Architectural Stained Glass** (3M421)

240-page presentation (1979) by Brian Clarke celebrates the work of 13 European and American artists involved with stained glass design since 1945. Full-color photographs accompany the text. \$26.75/\$29.50.

Books, Etc., to Order Through the Institute

***Architecture and Energy (3M279)**
322-page (1977) study by Richard G. Stein, FAIA, of the needless waste of resources in today's buildings and homes. The author outlines steps required to revolutionize the design process and provide more efficient and livable structures. \$11.75/\$12.95. Paperback, \$6.25/\$6.95.

***Architecture in America: A Pictorial History (3M229)**
832-page, two-volume set (1976) by G. E. Kidder Smith, FAIA, includes some 800 black and white photographs displaying historic and contemporary work. Structures are succinctly identified as to time, place, architect and significance and are grouped in seven geographic sections. \$18/\$19.95.

***The Architecture of Arthur Erickson (3M341)**
In this 448-page book (1975), Erickson records his philosophy regarding site, light and cadence—the concerns predominating the character of his work. \$36/\$40.

***The Architecture of Bruce Goff (3M373)**
135-page book (1978) by Jeffrey Cook, AIA, is intended as a survey of the work of Goff, providing an in-depth examination of a small number of his buildings. 120 illustrations complement the text. \$18/\$20.

B

***Back to the Drawing Board: Planning Livable Cities (3M408)**
245-page book (1978) by Wolf Von Eckardt, Hon. AIA, is an analysis of how to design cities "with" nature and not "against" it. *Washington Post* architectural critic, Von Eckardt's highly readable book is of interest to the professional and nonprofessional alike. \$9/\$10.

***Baroque Architecture (3M123)**
407-Page book (1971) by Christian Norberg-Schulz. Volume 2 of the History of World Architecture series. \$41.50/\$45.
Basics of Solar Heating and Hot Water Systems (3M262)
48-page publication (1977) from AIA Research Corporation discusses passive and active systems. Introduces systems design considerations, from collector components and placement, to storage and heat exchangers, to distribution. \$5.50/\$6.

***The Bed and Bath Book (3M346)**
In this 448-page book (1978), Terence Conran discusses beds and baths to suit every need or whim. Every area of the house is included from attic to cellar. \$31.50/\$35.

***Behavioral Architecture: Toward an Accountable Design Process (3M272)**
203-page book (1977) by Clovis Heimsath, FAIA, is a study and documentation of the often adverse psychological effects of buildings on people. Taken from an architect's viewpoint, it offers practical guidelines and step-by-step procedures to make certain the human element is included when designing viable buildings. \$19.50/\$21.50.

***Beyond Metabolism: The New Japanese Architecture (3M453)**
Michael Ross, AIA, captures the excitement and imagination of Japanese architecture in this 200-page guide (1978) to the work of some of the world's most innovative designers. Originally dubbed "Metabolists," these architects have gone "beyond metabolism" to achieve even more refined, articulate and interesting design solutions. \$20.25/\$22.50.

***BOD File: A Resource Book for Designers and Illustrators (3M343)**
By E. Denny and P. Terrazas, this source book contains 1,500 illustrations of human figures. They are drawn at architectural scale of one inch = one foot. Book includes section on automobile bodies, too. Paperback, \$13.50/\$15.

***Building Construction Illustrated (3M414)**
320-page manual (1975), by Frank Ching, containing step-by-step guidance on every technique of residential and light construction. Provides handy guidelines for cost estimating and construction sequencing. More than 1,000 illustrations. \$17.25/\$18.95.

***Building Contracts for Design and Construction (3M224)**
352-page book (1976, second edition) by Harold D. Hauf, FAIA, focusing on recent problems in professional liability. It identifies the principal contingencies that may arise, discusses the details of contract forms and suggests methods for handling disputes that will be equitable to all parties involved. \$22.50/\$24.95.

***Building Early America (3M219)**
407-page volume (1976) edited by Charles E. Peterson, FAIA, containing the proceedings of a symposium celebrating the 250th birthday of the Carpenters' Company of the City and County of Philadelphia. Contains chapters on the history of building and building materials and on historic preservation. \$17/\$19.95. Paperback (3M219P), \$8/\$9.95.

Building Underground for People: Eleven Selected Projects in the United States (4M711)
30-page report (1978) by Michael Barker, AICP, presents a sampling of underground projects in the U.S. Information

includes description of each project, owner, design team, contractor, size, cost, date of completion and decision to build subsurface. \$6/\$7.

***Building Without Barriers for the Disabled (3M232)**
80-page book (1976) by Sarah Harkness, FAIA, and James Groom, AIA, is an invaluable guide to designing public buildings that are safe, convenient and easily accessible to the physically handicapped. Numerous photographs illustrate design solutions for the special needs of disabled and elderly. Drawings and diagrams, in both inches and meters. \$10/\$10.95.

***Buildings for Commerce and Industry: Boutiques to Factories (3M369)**
In this 256-page book (1979), the editors of *Architectural Record* magazine present design solutions for commercial buildings. Clearly demonstrating the impact of building design on a business's profitability, selections show how to design for specific commercial needs, how to create designs compatible with commercial surroundings and how to decide when to remodel, expand or build new facilities. \$24/\$26.50.

***Buildings for the Arts (3M412)**
Prepared by the editors of *Architectural Record*, this 224-page book (1978) describes libraries, art museums, historical and regional museums, cultural centers and theaters. Illustrations include floor plans and technical data. \$29.25/\$32.50.

***Buildings Reborn: New Uses, Old Places (3M411)**
Barbaralee Diamonstein, in her 255-page book (1978), provides a 20-page explanatory introduction on preservation in general and adaptive use in particular. The 95 cases that follow give a brief but well-rounded look at adaptive use. Entries include the better known projects (Ghirardelli Square, etc.) as well as many little-known but equally useful cases. Paperback, \$9/\$10.

***Built to Last: A Handbook on Recycling Old Buildings (3M410)**
Written by Gene Bunnell, this 126-page book (1978) contains 33 major and several dozen shorter case studies of adaptive use projects with costs and construction details, organized by building type. Paperback, \$6.25/\$6.95.

***Businessman's Guide to Construction (3M451)**
450-page reference (1980) by Robert F. Cushman and William J. Palmer gives specific recommendations to the businessman and the advising professional

seeking to proceed through the construction process with understanding and confidence. The 13 chapters are organized to follow the construction process from the owner's viewpoint, though each chapter may be read independently. Presents effective guidance recommended by experts. \$31.50/\$35.

***Byzantine Architecture (3M221)**
383-page book (1974) by Cyril Mango. Volume 8 of the History of World Architecture series. \$40.50/\$45.

C

***Carpenter Gothic: 19th Century Ornamented Houses of New England (3M344)**
160-page volume (1978) by Alma de C. and Deidre B. McArdle documents, in text and photographs, the highly ornate, wooden ornamentation, known as Carpenter Gothic, in New England. \$22.25/\$24.50.

***Cast Iron Decoration: A World Survey (3M290)**
332-page book (1977) by E. G. Robertson and J. Robertson is a photographic inventory of the forms, national variations, relationships to architecture and contributions to buildings of cast-iron ornamentation. \$24.75/\$27.50.

***Castle (3M284)**
80-page book (1977) by David Macaulay, based in concept, structural process and physical appearance on several castles built to aid in the conquest of Wales between 1277 and 1305 A.D. For ages 10 and up. \$10.75/\$11.95.

***Cathedral (3M192)**
80-page book (1973) by David Macaulay, graphically explaining the creation of the cathedral, from the building of the foundation to the completion of the towers. Ages 10 up. \$10.75/\$11.95.

***Central City Malls (3M415)**
Offering complete, in-depth coverage of mall development, this 200-page book (1978) by Harvey M. Rubenstein illustrates how pedestrian malls have become an exciting part of the revitalization of downtown business districts. Analyzes factors that determine a mall's feasibility, size, location and cost. Contains 22 case studies and a catalog featuring complete data on 90 malls. \$23.50/\$25.95.

***Chair (3M314)**
144-page volume (1978), edited by Peter Bradford and Barbara Prete, reveals chairs as symbols of civilization—reflecting the personal motives of the designer and the nature of his market. Included among the 1,100 illustrations are

the 700 submissions to the 1977 AIA international chair design competition. \$18/\$19.95.

***Children's Spaces: 50 Architects and Designers Create Environment for the Young (3M377)**

In this 222-page book (1978), Molly and Norman McGrath have gathered examples of children's spaces under one cover. The main body of the text is given over to the designers' own discussions of their attitudes toward designing spaces for children—showing how space can be planned from the beginning to change as the child grows. \$27/\$29.95.

***City (3M193)**

112-page book (1974) by David Macaulay, showing the development of a Roman city, from the planning stage through construction. Ages 10 up. \$10.75/\$11.95.

***Compensation Guidelines for Architectural and Engineering Services, Second Edition (2M188)**

Prepared by AIA with the assistance of the American Consulting Engineers Council, this 160-page (1978) financial management tool places equal emphasis on both the architectural and engineering services required for building projects. Provides a rational process for relating design professionals' compensation to cost of services. Shows how to work with the client to analyze a project, item by item, to reach an agreement on scope of services required. \$12/\$15.

***Computer Aided Architectural Design (3M375P)**

573-page book (1977) by William J. Mitchell provides a comprehensive introduction to the subject of computer-aided architectural design. No detailed knowledge of programming is assumed, although some familiarity with a programming language will be helpful, as well as a knowledge of elementary algebra and trigonometry. The text is supplemented by several hundred original diagrams. \$15.25/\$16.95.

***Concepts in Architectural Acoustics (3M225)**

200-page book (1972) by M. David Egan, which includes chapters on basic acoustical theory, sound absorption, sound isolation, speech privacy, mechanical system noise and vibrations, room acoustics and sound reinforcing systems. \$29.25/\$32.50.

***Concepts in Building Firesafety (3M358)**

M. David Egan, in this 264-page book (1978), presents the principles of design for firesafety in an easy-to-follow graphic format. More than 270 illustrations help design professionals conceptualize problems and solutions of fire ignition and

spread in buildings, site planning, building materials and construction, fire detection and suppression systems for buildings, smoke and heat venting techniques, escape and refuge principles. \$24.50/\$27.

***Concepts in Thermal Comfort (3M186)**

224-page book (1975) by M. David Egan is a resource book on energy conservation design and construction principles. Text stresses the importance of integrating mechanical systems with building structures, minimizing building heat loss or heat gain and conserving valuable resources and energy. Illustrated with graphs, charts and numerous tables of technical and engineering data to aid in solving actual building problems.

Appendices provide useful formulae and additional references. \$13.50/\$14.95.

***Construction Bonds and Insurance Guide, Second Edition (2M163)**

Loose-leaf reference book (1979) prepared by Bernard B. Rothschild, FAIA, containing up-dated information on bonds and insurance related to construction projects, with glossary of insurance terms and suggested check list. \$16/\$20.

***Construction Business Handbook: A Practical Guide to Accounting, Credit, Finance, Insurance, and Law for the Construction Industry (3M368)**

Edited by Robert Cushman, this 760-page handbook (1978) is an efficient source of time-tested techniques for solutions to specific problems that arise time and again in the construction industry. Answers to questions involving accounting, insurance, contracts, bonds, bids and much more may be found in the 53 chapters of this authoritative reference. \$33/\$36.50.

***Construction Delay: Responsibilities, Risks and Litigation (3M246)**

384-page book (1976) by James O'Brien clearly explains legal definitions of delay, responsibilities of both building professional and client, role and liability of each participant in court proceedings and techniques for avoiding litigation altogether. Includes analyses of court cases involving the most frequently encountered problems in delay litigation. \$17.75/\$19.50.

***Construction Law in Contractor's Language (3M307)**

352-page book (1977) by McNeil Stokes deals with construction contracts in an up-to-date manner. Particularly valuable because it speaks in terms of practical problems, it is easy to read and understand. Included are chapters on bidding, general contracts, subcontracts, performance, insurance and how to collect your money. \$23.50/\$25.95.

***Converted into Houses (3M228)**
96-page book (1976) by Charles Fracchia and Jeremiah Bragstad serves as guide for creative recycling nonresidential buildings into houses. More than 30 dwellings-from-other-buildings, both in the U.S. and abroad, are discussed in lively text. Each dwelling shown as it was and as it is, accompanied by history of use and the process of conversion. 216 color photographs. \$13.50/\$15. Paperback (3M228P), \$6.25/\$6.95.

***Court House: A Photographic Document (3M340)**

256-page (1978) visual exploration, edited by Richard Pare, of a vital part of American life. A contribution to knowledge of this area of architecture—and history—of the U.S. \$31.50/\$35. Paperback (3M340P), \$17.25/\$18.95.

***Creative Communications for a Successful Design Practice (3M300)**

192-page book (1977) by Stephen A. Kliment, FAIA, is a tool for design professionals who want to develop skills and techniques needed to communicate effectively with present and potential clients, the media and the public. \$20.25/\$22.50.

***Current Techniques in Architectural Practice (2M701)**

275-page book (1976) edited by Robert Allan Class, AIA, and Robert E. Koehler, Hon. AIA. An overview of architectural practice, with emphasis on management, plus a comprehensive, annotated bibliography. \$22/\$27.50.

D

***Design and Planning of Swimming Pools (3M418)**

Comprehensive, 276-page manual (1979) written by John Dawes, a specialist in pool design, describes the essential characteristics and consequent design requirements of each type of pool, ranging from the small garden pool to public, school and therapeutic pools. The second portion deals in great detail with more technical matters: structural problems and how to solve them; how to select and apply finishes; filtration, circulation and water treatment; recommendations on heating and ventilating. Illustrated. \$45/\$50.

***Design Competitions (3M423)**

288-page book (1979), by Paul Spreiregan, FAIA, provides an historical survey of design competitions for architectural, landscape, industrial and city planning projects. It explains the actual mechanics of arranging, operating and entering a de-

sign competition and gives hints on the actual and proposed role of competitions. Illustrated. \$22.50/\$24.95.

***Design Cost Analysis for Architects and Engineers (3M454)**

Stressing the importance of a team effort among architect, structural, mechanical and electrical engineers, and cost managers, on every design effort, the 224-page book (1980) by Herbert Swinburne, FAIA, provides a workable method tied to a readily available cost data base for determining costs of 15 different building systems. Profuse examples and a hypothetical case study illustrate how to implement the procedures and avoid errors and liabilities. \$17.25/\$18.50.

***Design for a Limited Planet: Living with Natural Energy (3M313)**

215-page source-book (1977) by Norma Skurka and Jon Naar gives concise explanations of how solar heating systems work and how to design for solar energy use, and tells where to go for additional information on alternate energy systems. \$17.75/\$19.50, Paperback (3M313P) \$6.25/\$6.95.

***Design for Accessibility (3M416)**

Practical, 256-page on-the-job book (1979) by Robert James Sorensen explains graphically every currently developed standard and recommendation for handicapped access design. Drawings, dimensioned in both USCS and SI units, cover details involved in site development and parking, building access and circulation (halls, stairs, ramps, elevators), building areas, details and accessories. Latest codes, standards and regulations are detailed. \$20.75/\$22.95.

***Design of Cities (3M102)**

336-page book (Second edition, 1976) by Edmund N. Bacon, FAIA, comparing the spatial forms and subtle beauties of ancient and modern cities with a multitude of drawings, photographs, maps and plans. \$11.75/\$12.95.

Design Resources File: Planning Justice Facilities (2M714)

Prepared by the AIA committee on architecture for justice, this 83-page resource (1978) contains: a summary of the 1972 task force report on the state of the art in architecture for justice and some recommendations for action; guidelines for the justice planning process; resource and bibliographies pertaining to court, correctional and juvenile justice facilities, and an evaluation checklist for law enforcement facilities. \$8/\$10.

Design Review Boards: A Handbook for Communities (2M203)

52-page résumé (1974) of the law on design review and an annotated model

continued on page 120

dryvit® System, Inc.
OUTSULATION™

Pre-fabricated panels go up fast and easy.

The inverted pyramid structure (facing page) went up fast thanks to skillful application of Dryvit pre-fabricated panels. In this case, the panels were created nearby. They could have been trucked in to the site.

Cross-section of the panel system used by the architect is shown.

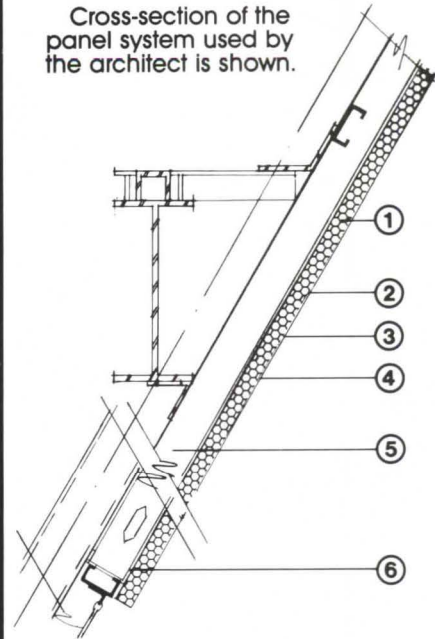

- 1. Dryvit Insulation Board:** a rigid panel of expanded polystyrene with optimum insulating characteristics. Board sizes, thicknesses and shapes are available as required by design.
- 2. Dryvit Reinforcing Fabric:** specially woven and treated fiberglass fabric is embedded in the Primus coating to prevent surface cracking.
- 3. Dryvit Primus/Adhesive:** Dryvit's unique plaster material mixed with Type I Portland Cement is used to adhere Dryvit Insulation Board to backup surface. It is also used to embed Dryvit Reinforcing Fabric on the face of the board.
- 4. Dryvit Quarzputz Finish:** one of four finishes available. This synthetic plaster material has high bond strength, permanent integral color and an applied texture that provides a weatherproof jointless exterior surface.
- 5. 4" x 16 ga. "C" stud at 16" O.C.**
- 6. 5/8" exterior grade gypsum sheathing conforming to federal specification SS-L-30D, Type II, Grade W, Class 2 and ASTM C-79.**

DRYVIT SYSTEM, INC.

420 Lincoln Avenue, Warwick, RI 02888
(401) 463-7150

Plant Locations: Warwick, RI and Tulsa, OK

Massive insulation used as an integral skin creates a new perspective in energy saving.



OUTSULATION™

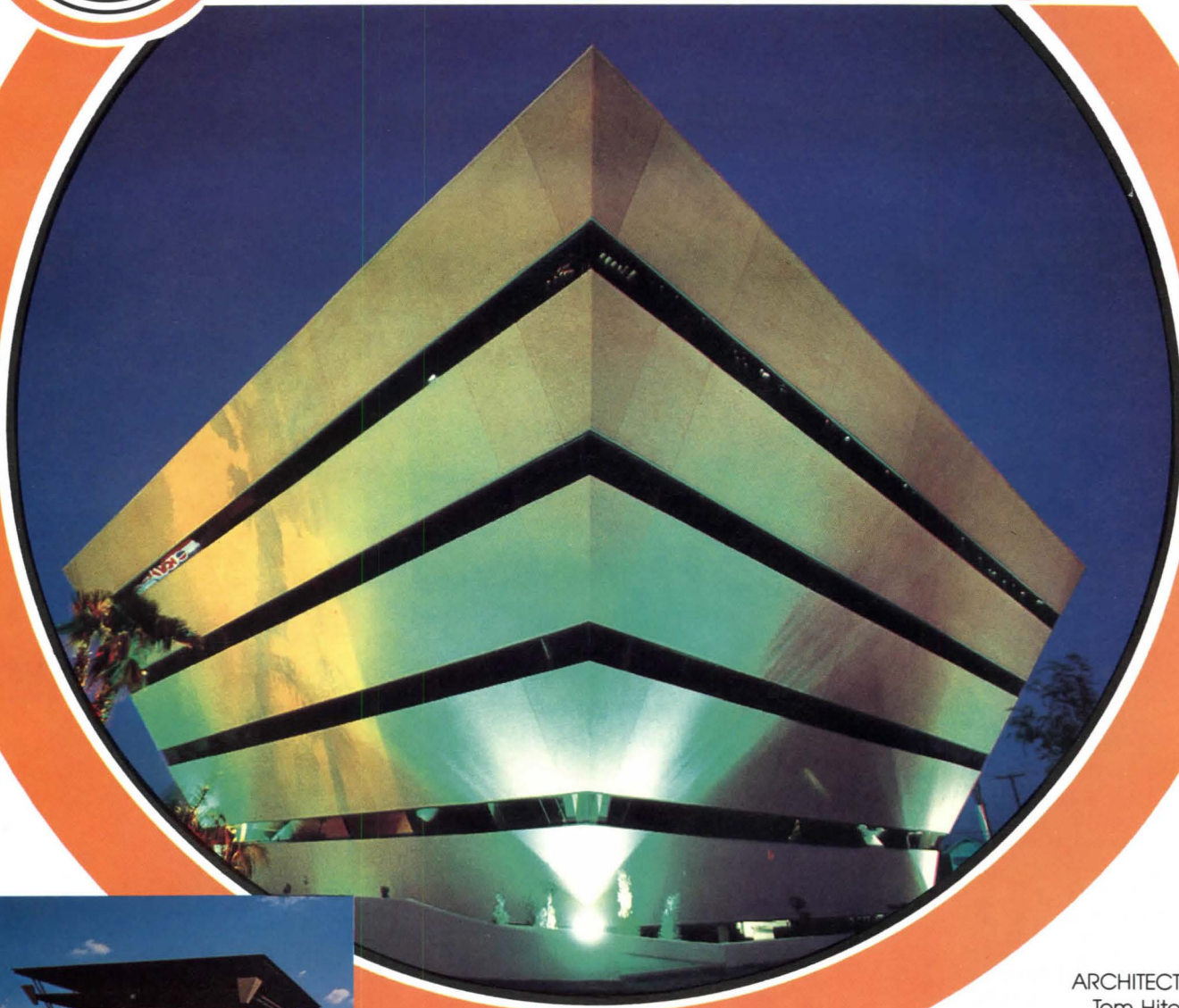

ARCHITECT
Tom Hite
Denver, CO

The pyramid is ancient history. But in this Phoenix, Arizona building, the pyramid is a dichotomy. On one hand, its inverted shape creates a mood of modernity. On the other hand, it was erected by using some good old fashioned work methods. The building which houses the offices of Security Mortgage Corp. and its lessees, stands four floors high. Each floor carries an overhang of more than 10 feet. In all, a total overhang of 44 feet. A 30 foot tree could grow within its shelter.

Another remarkable feature about the structure is the time it took to build. Just two and a half months from start to finish.

Unique methods were used. The Dryvit System was prefabricated on steel stud panels which were constructed on an adjacent lot. The block and tackle method was used to hoist the panels into position. And it needed only a crew of 3 lathers, 2 plasterers and a plaster tender to put up the 16,500 square feet of walls.

They made a mock-up of a single corner and adjusted it until it was correct. Then they built all the corners and put them in place first. They measured the distance between each corner and fabricated the exact size to fit each floor.

Obviously, Dryvit's lightweight and ease of application were two reasons why this structure went up so fast. And as Dryvit went up, it also provided Outsulation™, the massive insulation that saves energy while it looks beautiful.

The Dryvit System works in this inverted pyramid. Let us prove it can work for you. Call or write, stating your application: new construction or retrofit.

dryvit SYSTEM INC.®

420 Lincoln Avenue, Warwick, RI 02888 • (401) 463-7150 • Plant Locations: Warwick, RI and Tulsa, OK

Circle 47 on information card

Books from page 118

ordinance to guide communities that choose to adopt a design review board process. \$5.60/\$7.

***Design Through Discovery, Third Edition (3M357)**

404-page basic introduction (1977) to the elements and principles of visual expression, by Marjorie Elliott Bevin. Contains more than 600 photographs illustrating the concepts in the book with examples of all areas of design—from the contemporary rock concert to the marble sculptures of Michelangelo. \$17.75/\$19.50. Paperback (3M357P), \$13.50/\$14.95.

***Designing and Building a Solar House: Your Place in the Sun (3M251)**

288-page book (1977) by Donald Watson, AIA, demonstrates the most sensible ways to combine good residential design with contemporary solar heating technology within building costs of conventional homes. Delves into topics such as active and passive solar heat systems, hot water systems, calculating wind, temperature range and sun exposure factors on the sites. Includes complete checklist of equipment needs and a comprehensive source list of products and material. More than 400 illustrations. \$12.75/\$13.95. Paperback (3M251P), \$9/\$9.95.

***Designing for the Disabled, Revised Third Edition (3M356)**

Comprehensively updated and completely rewritten, this 525-page (1976) classic by Selwyn Goldsmith is a helpful aid for all who are concerned with the planning and management of buildings used by handicapped people. Using 478 diagrams to guide the designer, this book is a reproach to traditional attitudes of building design, in which the disabled have been largely ignored. \$42.75/\$47.50.

***Designing for Human Behavior: Architecture and the Behavioral Sciences (3M240)**

Edited by Jon Lang, and others, this 368-page book (1974) is concerned with raising the standard of the designed environment to meet human needs on as many levels as possible. Designers interested in the human element of their work will benefit from this book. Paperback, \$14/\$15.50.

***Designing Houses: An Illustrated Guide (3M336P)**

152-page book (1976) by Lester Walker and Jeffrey Milstein is an introduction to the tools and methods of designing a home structure for those interested in architecture, ages 12 and up. Paperback, \$5.25/\$5.95.

***Designing the Open Nursing Home (3M289)**

175-page book (1976) edited by Joseph A. Koncelik offers much needed research on the social, behavioral and physiological characteristics of the elderly infirm. Provides a clear guide to developing microenvironments that are residential in nature rather than sterile and institutional. \$21.25/\$23.50.

Development Building: The Team Approach (2M135)

130-page guide (1972), by C. W. Griffin, to project development. Since the development process is too complex and varied to be defined in simple, unvarying formulas, this book attempts to prescribe general rules. \$16/\$20.

A Directory of Minority Architectural/Engineering Firms (2M709)

The directory (1978) prepared by AIA and the American Consulting Engineers Council (ACEC) lists both member and nonmember minority architectural and engineering firms nationwide. \$5/\$10; \$5 for ACEC members.

***Doors (3M405)**

144-page book (1979) by Val Clery offers a kaleidoscope of full-color photographs (158) that show how astonishingly varied, intriguing and significant doors can be. The book has all the fascination of a walking tour through an unfamiliar city where every turn brings new discoveries. \$13.50/\$14.95. Paperback (3M405P), \$9/\$9.95.

***Downtown U.S.A.: Urban Design in Nine American Cities (3M370)**

In this 272-page book (1978), Kenneth S. Halpern examines the urban policies and planning in nine major U.S. cities: New York, Chicago, Philadelphia, Houston, Washington, D.C., San Francisco, Boston, Atlanta and Minneapolis. Illustrated with 350 black-and-white photographs. \$24.75/\$27.50.

***Drawings by American Architects (3M154)**

613-page book (1973) by Alfred M. Kemper, AIA, which is a collection of renderings from more than 100 architectural offices illustrating a wide range of techniques and various viewpoints. \$45/\$49.95.

E

***Earth Sheltered Handbook (3M456)**

Written by Tri/Arch Associates, this 244-page handbook (1980) is neither totally technical nor theoretically abstract but a mixture of both. Principles of site selection and preservation are presented, as well as graphic and verbal descriptions of

various structural and building subsystems, construction details and techniques. Illustrated. \$11.75/\$12.95.

***Earth Sheltered Housing Design: Guidelines, Examples, and References (3M381)**

310-page book, produced by the Underground Space Center at the University of Minnesota, is the first comprehensive manual on underground housing design. It introduces the basic considerations of earth sheltered design and presents detailed layouts and photographs (300) of existing houses, built in both warm and cold climates. Offers precise information on financing, building codes, product information and a bibliography. \$16.25/\$17.95. Paperback (3M381P), \$9/\$9.95.

***Earthquake Resistant Design: A Manual for Engineers and Architects (3M143)**

In this 374-page book (1977), D. J. Dowick spells out the earthquake-resistant design process—from risk analysis through detailing—in logical design office sequence, explaining each stage along the way. Gives details on soils, foundations, superstructure and nonstructure. \$41/\$45.50.

***Earthscape: A Manual of Environmental Planning (3M337)**

340-page book (1977) by John Ormsbee Simonds is a comprehensive and positive book on environmental quality. The author shows what architects, engineers and concerned citizens can do to assure that tomorrow's communities will be livable and productive. \$31.25/\$34.50.

***Energy Conservation Design Resource Handbook (4M428)**

450-page handbook (1979) summarizes systematically all design principles and related architectural, engineering, planning and economic considerations applicable in architectural design. Prepared by the energy task force of the Royal Architectural Institute of Canada, the information on energy conserving measures is written in a concise manner using a blend of easily understood tests, diagrams, charts, illustrations and calculations in metric measurements. Loose-leaf binder. \$75/\$80.

Energy Conservation in Building Design (4M212)

Prepared by the AIA Research Corporation, this 156-page book describes opportunities for conserving energy through building design. It is the product of a national energy policy study financed by the Ford Foundation to investigate various aspects of the technological and social impacts of energy supply and consumption. \$5.

***Energy Conservation in Buildings (3M184)**

183-page book (1975) by Charles W. Griffin which contains a subject-by-subject examination of the building items that offer opportunities for reduction in energy use. \$20.

***Energy Conservation Standards (3M371)**

Written by Fred S. Dubin and C. G. Long Jr., AIA, this 413-page comprehensive guide (1978) gives the practical methods for managing energy in any structure designed, built, maintained or operated. Contains checklists and charts needed to trace and measure the energy flow in every given building, from heat loss in walls and roofs to the economics of HVAC and electrical systems. \$22.50/\$24.95.

***Energy Conservation Through Building Design (3M389)**

Edited by Donald Watson, AIA, this 224-page book (1979) comes in response to today's growing concern with the conservation of energy. It is comprised of key articles and references that outline the basic concepts and directions necessary for energy efficient building design; a reliable source for guidelines. \$20/\$21.95.

***Energy Handbook (3M396)**

640-page book (1978) by Robert L. Loftness is a major compilation and survey of energy resources, costs, conservation, efficiency, depletion, storage, transport, consumption, conversion technologies and environmental factors. It covers such areas as nuclear, oil, geothermal, coal, wind, solar and tidal energy sources. \$44.75/\$49.50.

Energy Planning for Buildings (4M720)

Written by Michael Sizemore, AIA, et al., this 156-page book (1979) presents a proven process that design professionals can use (or adapt) to study the current energy performance of a building, uncover opportunities for energy-conscious improvements, evaluate those opportunities and see that they are carried out to the building owner's best benefit. Describes in detail a manual technique for calculating energy usage and shows in a sample problem how that technique can be applied. Also provides a basis for understanding computer-aided energy estimating techniques. \$40/\$44.

F

***Facility Programming: Methods and Applications (3M361)**

Edited by Wolfgang F. E. Preiser, this

352-page book (1978) provides an authoritative overview of current user oriented programming approaches. Topics covered range from problem definition, cross-cultural programming and post-occupancy evaluation to adaptive use and other more specific examples of facility programming. \$33.50/\$37.

***The Federal Presence: Architecture, Politics, and Symbols in U. S. Government Building (3M384)**

Prepared by Lois Craig and the staff of the federal architecture project, this profusely illustrated 608-page reference (1978) is a sort of American album, a

scrapbook of a special aspect of our cultural history. Post offices, courthouses and other government structures of the most utilitarian purpose have followed the fashions of their day and have contributed much to America's architectural tradition. \$33.75/\$37.50.

Financial Management for Architects (2M724)

The "umbrella" book of the AIA financial management systems, the 200-page manual (1980), by Robert Mattox, AIA, covers basic theories and applications appropriate to all size design firms. It examines financial goals, profit planning

MEDUSA

for Creative Concrete Construction



Whatever your concrete construction requirement — Medusa makes the cement to fill your creative need.

MEDUSA WHITE PORTLAND CEMENT — lends itself to unlimited architectural creativity in color, form and texture. Write for colorful, informative brochure.

MEDUSA CUSTOM COLOR MASONRY CEMENTS — provide the modern building team with a wide assortment pre-mixed masonry cement colors. Colors that will enhance the aesthetic beauty of modern masonry — as well as its acceptance.



Call Sweet's Buy-Line 800-447-1980
or — the Medusa number below.

MEDUSA CEMENT COMPANY

P.O. Box 5668

Cleveland, Ohio 44101 (216) 371-4000.

and the interrelationships of accounting reports, financial controls and the broad view of managing firm finances. Illustrated. \$22/\$27.50.

***For Pedestrians Only: Planning, Design and Management of Traffic-Free Zones** (3M278)

This 208-page book (1977) by Roberto Brambilla and Gianni Longo is a comprehensive study of the complex process of eliminating all the noise, pollution and turmoil from urban spaces. By summarizing and analyzing what has been achieved, the book offers a resource to guide future efforts to make cities more habitable. \$22.50/\$24.95.

***The Form of Housing** (3M359)

Sam Davis, AIA, edited this well-illustrated 299-page book (1978) which provides a broad range of elements that must be considered in the planning and production of dwellings. Describes the main forms of urban housing during the past three decades. Examines changing attitudes of builders and developers, the movement toward conservation of old housing, plus numerous projects. There are also extensive bibliographies. \$22.25/\$24.50.

***Frank Lloyd Wright's Usonian Houses: A Case for Organic Architecture** (3M328)
John Sergeant, in this 205-page book (1976), analyzes Wright's philosophy of building *with* nature rather than against it. Wright's later work has a new relevance as energy conservation and ecological integrity have become dominant concerns of this era. \$22.25/\$24.50.

Funding Sources for Architectural Programs: Foundations Supporting the Built Environment (2M719)

A 150-page funding source listing (1978) compiled by the AIA Foundation and the National Endowment for the Arts. Contains essential information on more than 200 foundations that support the built environment. \$8/\$10.

G

Glossary of Construction Industry Terms (2M101)

18-page publication (1970), including definitions of terms with special meaning or connotation in the construction industry. \$1.25/\$1.50.

***Gothic Architecture** (3M285)

444-page book (1977) by Louis Grodecki. Volume 9 of the History of World Architecture series. \$40.50/\$45.

***Great Houses for . . . View Sites, Beach Sites, Wood Sites, Steep Sites, Flat Sites** (3M293)

248 pages (1976), edited by Walter F. Wagner, AIA, of 68 exceptional houses, illustrated in more than 300 photographs and plans, show how a house can be designed to suit almost any site. Principles of design that create an interesting, workable and convenient house that takes advantage of its natural surroundings. \$21.75/\$23.95.

***Great Moments in Architecture** (3M315)

This 114-page portfolio (1978) by David Macaulay shows a fresh and beguiling side to his talents. For example: the plans for the Tower of Pisa on a skewed drafting table; the Eiffel Tower tipped over across the Seine and many other gems. \$10.75/\$11.95. Paperback, \$5.50/\$5.95.

***Greene and Greene: Architecture as a Fine Art** (3M376)

This 288-page book (1978) by Randell Makinson is a comprehensive study of Greene and Greene. It combines biography with descriptive analysis of all their major works. Photographs and drawings embellish and illustrate the text. \$25.25/\$27.95.

***Greene & Greene: Furniture and Related Designs** (3M385)

In this beautifully illustrated, 162-page book, Randell Makinson shows the exquisite taste and sensitivity of the Greene brothers, revealed through their highly integrated designs for architectural furnishings. Masters of the California crafts tradition, they believed that all elements of a house should be interrelated, adding to and defining the architectural statement. \$25.25/\$27.95.

***Gritty Cities: A Second Look at . . .** (3M380P)

This 276-page, extensively illustrated book (1978) by Mary Proctor and Bill Matuszeski is a personal response to the physical landscape of the gritty cities: an assessment of the place of 12 cities in the Industrial Revolution and the present. Demonstrating the human scale possible in architecture, it gives a new, kinetic vision of the small city whose beauty is most apparent in the juxtaposition of smokestack and neoclassic facades. \$9/\$9.95.

***A Guide to Architecture in Los Angeles and Southern California** (3M393)

This 600-page guidebook (1977), by David Gebhard and Robert Winter, contains 3,000 entries for the geographic area extending from San Simeon on the north to the Mexican border on the south and the island deserts on the east, includ-

ing the San Joaquin Valley. The tourist is provided with 1,000 illustrations, including maps and descriptions, plus a glossary and bibliography. Paperback, \$10.75/\$11.95.

***A Guide to Architecture in San Francisco and Northern California** (3M392)

Published for the 1973 national AIA convention, the 560-page guide by David Gebhard, et al., contains a wealth of maps for ease in touring, along with succinct descriptions of the various areas visited and buildings viewed. Includes a glossary and bibliography along with 600 illustrations. Paperback, \$8.25/\$8.95.

***A Guide to New Orleans Architecture** (3M382)

Prepared by the New Orleans Chapter/AIA, this 177-page guidebook provides suggestions, with maps, for 18 separate tours. Beginning with the French Quarter (Vieux Carre), it leads the tourist through neighborhoods of small, narrow Victorian "shotguns" or "camelbacks" (a pictorial glossary is provided) to the large-scale houses of the Garden District, to the newer suburbs, following a full range of architectural styles. Paperback, \$5.50/\$5.95.

H

***Handbook of Building Security Planning and Design** (3M400)

Edited by Peter S. Hopf, AIA, this 576-page handbook (1979) provides comprehensive design information on all aspects of physical security for every type of building. Deals with the unique safety requirements for differing buildings—libraries, schools, highrise office buildings, health care facilities and many others—each with its own particular needs. Diagrams, charts, checklists and a security product directory are included. \$34.75/\$38.50.

***Heating, Ventilating, and Air-Conditioning Estimating Manual** (3M305)

This 352-page book (1977) by A. E. Khashab covers the latest estimating techniques and most advanced information on HVAC systems design. This practical guide begins with HVAC estimating criteria, followed by detailed discussion of all major HVAC systems and components, including relevant design, installation and estimating information. \$26.75/\$29.50.

***High-Tech: The Industrial Style Source-Book for the Home** (3M352)

This 288-page book (1978) by Joan Kron and Suzanne Slesin shows how

commonplace industrial and commercial products can be used in the home. Includes description, prices, names and addresses of manufacturers. \$27/\$29.95.

***Hospital and Health Care Facilities (3M345)**

This 193-page volume (1978), edited by Louis Redstone, FAIA, helps solve overall planning and construction problems; covers the gamut from small clinics to large public hospitals. \$29.25/\$32.50.

***Hospital Planning Handbook (3M134)**
242-page book (1976) by Rex Whitaker Allen, FAIA, and Ilona von Karolyi, which outlines the processes involved in planning health care facilities and hospitals. \$21.25/\$23.50.

***Hotels, Motels, and Condominiums: Planning and Design (3M243)**

250-page book (1976) by Fred Lawson is a reference source on marketing and research, architectural design, engineering data and operations analysis of hotels and other tourist facilities. Covers everything from cocktail lounges to sleeping rooms to back-of-the-house mechanical equipment. Discusses current international trends and up-to-date standards affected by such things as energy short-

ages, new concepts of safety, comfort and noise reduction. 150 illustrations. \$36/\$39.95.

***The House Book (3M347)**

This 448-page book (1976) by Terence Conran provides a thorough discussion of home planning, decorating, maintenance and repair, covering everything from window decor to wine cellar. \$31.50/\$35.

***A House Is a House for Me (3M350)**

In this 48-page illustrated book (1978), Mary Ann Hoberman describes all kinds of houses through rhythmic verse.

Teaches small children the concepts of space, containers and shelter. \$5.50/\$5.95.

***Housebuilding for Children: Six Different Houses That Children Can Build for Themselves (3M334)**

A 175-page (1977) do-it-yourself guide by Lester Walker for children, parents and teachers based on the actual experiences of a crew of children ages seven to ten. \$10/\$10.95.

***Houses Architects Live In (3M302)**

This 168-page book (1977) by Barbara Plumb, presents well-designed houses and apartments—from modest to lavish, all emphasizing ingenious ways of combining beauty and practicality. All have

interiors alive with ideas suitable for adaptation to all types of living situations. \$16.25/\$17.95. Paperback, \$9/\$9.95.

***Houses of the West (3M391)**

Celebrating the Western house as a fresh, flexible design concept, this 224-page, exceptionally illustrated book (1979), edited by Elisabeth K. Thompson, FAIA, features the work of some of America's leading architects. Designs for a wide variety of terrains, climatic conditions and user needs are included. \$18/\$19.95.

***Housing (3M237)**

This 483-page book (1976) by John Macsai, FAIA, and others, provides a methodical approach to housing design. Dissects housing into its various components, sets forth up-to-date information on each. Deals with the data architects should gather to intelligently design housing: architectural, structural and mechanical components of design; design methodology; financing. \$38.25/\$42.50.

***Housing for the Elderly: The Development and Design Process (3M142)**

A 174-page (1975) ready-to-use guide, by Isaac Green, AIA, and others, for producing high quality housing for older Americans. Pinpoints housing which

Stains, Waxes, Seals...in one operation

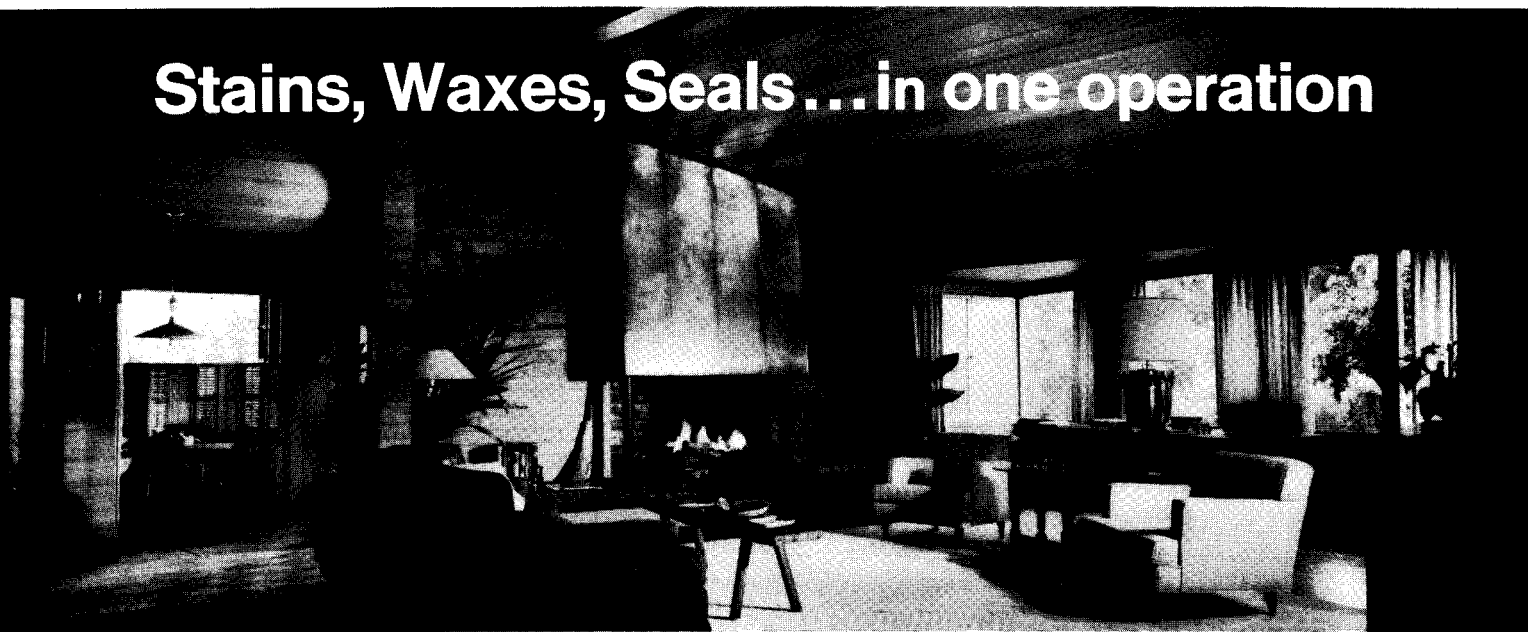

California home; Designer: Russell Forester, La Jolla, California; Cabot's Stain Wax on all interior woodwork

Cabot's STAIN WAX

This unique "three-in-one" finish, suitable for all wood paneling, beams, and woodwork, brings out the best in wood, enhancing the grain and producing a soft, satin finish in a choice of thirteen colors plus ebony, white, and natural. When a flat finish is desired, specify Cabot's Interior Stains for all interior wood surfaces.



Samuel Cabot Inc.

One Union Street, Dept. 845 Boston, Mass. 02108

- Send color cards on Stain Wax and Interior Stains
 Please send Cabot's handbook on wood stains

meets physical, social, perceptual needs of senior citizens. Emphasizes types of shelter, environments and services required by both the independent elderly and those who need limited health and social services. \$17.25/\$18.95.

***How a House Happens (3M287)**

This 29-page book (1971) by Jan Adkins shows the very young reader how a house grows and is brought to life by craftsmen. It begins with roots in the ground and grows up and out to give shelter, like a tree. \$5.50/\$5.95.

***How to Prepare Professional Design Brochures (3M223)**

277-page book (1976) by Gerre Jones, Hon. AIA, to guide those planning a promotional brochure showcasing their professional services. Discusses the procedure from start to finish, including the areas of scheduling, budget, layout, copywriting, type, paper and printing. Shows numerous examples, and also covers supplemental publications such as newsletters. \$22.50/\$24.95.

***How to Recycle Buildings (3M425)**

245-page book (1979), by Laurence E. Reiner, shows how to successfully rehabilitate or recycle structurally sound buildings for profit. The author presents the practical "how-to's" on finding, evaluating, surveying, financing and marketing recycling projects profitably. In addition to case studies, numerous illustrations, graphs, charts and tables are included. \$18/\$19.95.

***Huts,hovels and Houses (3M351)**

This 48-page book (1978) by Timothy Fisher, for ages 12 and up, provides directions and suggestions for building a variety of shelters—inflatable tetrahedrons, a house of cans. Includes such

luxuries as a solar heated bathtub. \$6.25/\$6.95.

I

***I. M. Pei & Partners: Drawings for the East Building, National Gallery of Art (4M403)**

Prepared by the Adams Davidson Galleries, this 55-page catalog (1978) contains portions of the sketches, renderings and models used in the exhibit, developed by the galleries, documenting the design evolution and construction of the east building, 1968-1978. Paperback, \$6.

***Interior Landscaping: Building Design for Interior Foliage Plants (3M301)**

This 200-page book (1977) by Richard L. Gaines, AIA, includes information on physical requirements of plants, what conditions they need and how to select plants that do best indoors. A special full color section displays and discusses more than 75 of the most popular varieties for indoor use, providing details of lighting, moisture and temperature needs. \$23.50/\$25.95.

***Interiors 2nd Book of Hotels (3M395)**

In this profusely illustrated, 224-page book (1978), Henry End discusses the changes in the hotel industry in the past 15 years. Subjects covered include: the design team, the consultants, types of hotels, hotel spaces and their function and much more. \$24/\$26.50.

***Into the Mainstream: A Syllabus for a Barrier-Free Environment (3M132)**

44-page report (1975) by Stephen Kliment, FAIA, containing practical information on how a community can achieve a barrier-free environment. \$2.75/\$3.

***Islamic Architecture (3M317)**

A 424-page book (1975) by John D.

Hoag. Volume 11 of the History of World Architecture series. \$40.50/\$45.

J

***Joint Ventures for Architects and Engineers (3M139)**

205-page book (1972) by David R. Dibner, FAIA, which covers all the important details of joint ventures with step-by-step procedures. \$25.75/\$28.50.

K

***The Kitchen Book (3M348)**

Terence Conran provides thousands of ideas, in this 352-page book (1977), for making kitchens attractive and functional. Discusses ways to design the ideal kitchen. \$31.50/\$35.

L

***Late Baroque and Rococo Architecture (3M178)**

415-page book (1974) by Christian Norberg-Schulz. Volume 3 of the History of World Architecture series. \$40.50/\$45.

***Legal Aspects of Architecture and Engineering, Second Edition (3M319)**

In this 987-page volume (1977), Justin Sweet discusses the antitrust attacks on traditional professional practices relating to fees and clients. Also covers construction organization techniques such as construction management, fast track systems and design/build. \$18/\$19.95.

SOUNDBLOX[®]

Sound-Absorbing Structural Masonry Units

CONTROL NOISE



The Proudfoot Company, Inc.

See Sweet's General Building (Architectural) or Industrial Construction Files (9.1/P) or Spec-Data, or phone us collect.
Nationwide availability... made near your jobsite!

ACOUSTICAL PRODUCTS P.O. BOX 9, GREENWICH, CONNECTICUT 06830 A/C 203 869-9031

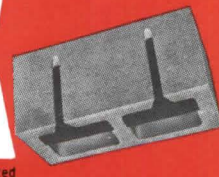

Life Cycle Cost Analysis: A Guide for Architects (2M708)

Provides architects, engineers and clients with a straightforward and usable technique allowing them to consider all relevant economic consequences of design decisions. A 45-page primer (1978) prepared by the life cycle cost analysis task force of AIA. Paperback, \$8/\$10.

Life Cycle Cost Analysis 2: Using It in Practice (2M713)

This 88-page book (1978) responds to the critical question: Where in the planning and design process can the life cycle cost analysis technique be effectively used? Provides guidelines for selecting application areas and a number of case study applications, as well as commentary on the planning and design process. In conjunction with the first life cycle guide, the publication presents an introduction to the life cycle cost analysis technique and a picture of its current use in practice. Paperback, \$14.50/\$18.

Life Experiences in Environmental Design (4M127)

267-page publication (1975) containing interviews with students and recent graduates about their aspirations, travails, satisfactions, etc. \$4.

***Living Spaces: 150 Designs from Around the World** (3M386)

Franco Magnani edited this 120-page book (1978) which provides a wealth of imaginative and practical ideas for home planning and decoration for people confronted with the problems of confined living space. The full color photographs demonstrate interiors to satisfy esthetic as well as practical needs. \$20.25/\$22.50.

***Living with Energy** (3M320P)

This 128-page book (1978) by Ronald Alves and Charles Milligan shows how the "natural way" of energy conservation (sun, wind, land and water) can be used economically and attractively in any structure. Paperback, \$5.50/\$5.95.

***Looking into Houses: 60 Solutions to Design Problems** (3M294P)

This 192-page book (1976) by James Brett is a photographic portfolio of some of America's most personable homes, selected for the problem-solving skill and ingenuity shown in creating inviting living space. \$9/\$9.95.

M

***Manual of Steel Construction, Eighth Edition** (3M117)

Here is an essential reference for architects, engineers and many others concerned with the construction industry. More than 1,100 pages, this latest edition (1980) is based on the provisions of the AISC "Specification for the Design, Fabrication and Erection of Structural Steel for Buildings." Data are divided into six basic sections, with a comprehensive index for easy access to information. \$32.50/\$36.

***The Master Builders** (3M329)

A 299-page survey (1977) by Henry Cowan of building design achievement from ancient times to the 19th century. \$22.25/\$24.50.

***Minimum Energy Dwelling (MED) Workbook: An Investigation of Techniques and Materials for Energy Conscious Design** (4M366)

Written for the Department of Energy by Burt, Hill & Associates, this 430-page workbook (1978) presents, in a comprehensive manner, important issues dealing with energy conservation in dwellings:

Designing a computer center is no small task.

Call **DATA PROCESSING SECURITY, INC.** for 10 years experience in all phases of computer center design.



- Data Center planning/programming
- Equipment specifications
- Security design implementation

- Field inspection
- Client training

DATA PROCESSING SECURITY, INC.

For free brochure write: 200 E. Loop 820, Ft. Worth, TX 76112
817-457-9400

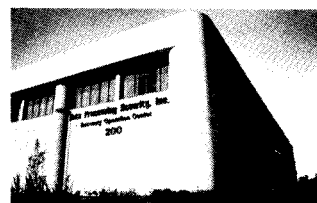

Structural design

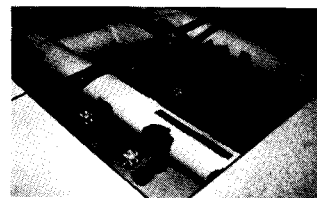

Mechanical



Electrical



Security



© 1980

WITH CHENEY

RENOVATE

Cheney's "new look" panels can give older buildings an affordable face lift. Outdated exteriors take on a modern, colorful and economical new lease on life—and profits—with Cheney mansard, fascia and soffit panels.

Send for "New Youth" and Profitability for Older Buildings" brochure.



A company in touch with your needs.

CHENEY
FLASHING COMPANY

ESTABLISHED 1928
623 Prospect Street
P.O. Box 818
Trenton, N.J. 08605
Phone 609-394-8175

general considerations, building design, mechanical design. Includes a glossary. Paperback, \$9/\$10.

***Model Building for Architects and Engineers (3M133)**

152-page working guide (1971) by John Rueger Taylor to well-executed, realistic models for architectural, engineering and interior designs. \$24.75/\$27.50.

***Modern Architecture (3M450)**

Written by Manfredo Tafuri and Francesco Dal Co, this 459-page book (1976) is the latest volume in the History of World Architecture Series. Beginning with the rise of urbanism in 19th century America, it includes work by giants such as Hunt, Richardson, Sullivan, Le Corbusier, Wright, Mies and many others. Profusely illustrated. \$40.50/\$45.

N

***Natural Solar Architecture (3M322)**

254-page handbook (1978) by David Wright, AIA, for those wanting to find out more about the passive approach to solar architecture. Shows the natural and simple approach in designing homes. Paperback, \$8.25/\$8.95.

***NCARB Design Test Handbook (3M427)**

94-page study guide (1979) for Section A of the NCARB professional examination contains actual design solutions by candidates to the 1979 problem, together with expert critiques by NCARB's examinations coordinating council. Will be updated annually. \$16.25/\$18.

New Design Concepts for Energy Conserving Buildings (2M263)

124-page book (1977) describes 115 innovative approaches to designing energy-efficient buildings. Contains bibliography and design concept index keyed to drawings. \$9/\$9.95.

***New Dimensions in Shopping Centers and Stores (3M158)**

323-page book (1973) by Louis Redstone, FAIA, on every phase of planning and constructing shopping centers. \$29.25/\$32.50.

***The New Downtowns: Rebuilding Business Districts (3M222)**

330-page book (1976) by Louis G. Redstone, FAIA, concerned with rescuing and revitalizing the deteriorating central city. Focuses on imaginative urban renewal projects through case studies of central business districts in 56 cities in the U.S., Canada and abroad. \$31.25/\$34.50.

***New Profits from Old Buildings (3M422)**

Written by Raynor M. Warner, et al., the 71 projects profiled in the 295-page book

(1978) illustrate the ways in which business has made use of existing buildings or given support to others for their preservation. Case studies provide useful examples for those interested in building and community preservation. \$22.25/\$24.50.

***New Uses for Old Buildings (3M327)**

This 280-page book (1975) by Sherban Cantacuzino is a good reference for those looking for ways to adapt old buildings to current requirements. Discusses 73 internationally selected examples of recent conversions. \$27/\$29.95.

O

***Office Planning and Design (3M267)**

193-page book (1968) by Michael Saphier presents space planning and the design effort in the logical sequence of an actual project. How-tos included are: how to analyze the space required by your client; obtain this space; set up a new building program; prepare a space study; budget a program, and set up a design presentation. \$27/\$29.95.

***The Old House Catalog (3M299)**

Compiled by Lawrence Grow, this 240-page book ends the difficult chore of finding old materials and objects, or places that fashion reproductions. Listed under one cover are 2,500 products, services and suppliers for restoring, decorating and furnishing period houses from early American to 1930s modern. Paperback, \$7.25/\$7.95.

***Open Office Planning: A Handbook for Interior Designers and Architects (3M388)**

By John Pile, this 208-page handbook (1978) presents a systematic approach that requires use of specific methodology in organizing the physical layout of an open office with the primary purpose of facilitating communication among the staff. \$15.25/\$16.95.

***Opportunities in Architecture Today (3M112A)**

117-page book (1975) by Robert J. Piper, FAIA, analyzing all occupational facets of the architectural profession. Paperback, \$5.25/\$5.95.

***The Opulent Eye: Late Victorian and Edwardian Taste in Interior Design (3M339)**

In this 258-page source-book (1976), Nicholas Cooper traces the changes in English and American taste in the ways

of furnishing interiors during the years of 1890-1914. \$22.50/\$25.

***Oriental Architecture (3M191)**
435-page book (1975) by Mario Bus-sagli. Volume 6 of the History of World Architecture series. \$40.50/\$45.

***Outdoor Sculpture: Object and Environment (3M330)**
Margaret A. Robinette's 192-page study (1976) discusses variety, significance and functions of outdoor sculpture and its use in contemporary society. 175 photographs. \$22.25/\$24.50.

P

***Painted Ladies: San Francisco's Newly Repainted Victorians (3M409)**
An 80-page pictorial survey (1978) by Morley Baer and others, tracing the history of San Francisco's 16,000 Victorian houses built between 1850 and 1915. Many have recently been repainted in the original bright colors, and are presented in the 133 full color photographs. Paperback, \$10/\$10.95.

***Passive Solar Energy Book: Expanded Professional Edition (3M399)**
This comprehensive, 548-page book (1979) by Edward Mazria contains information that will be invaluable to the serious solar designer. Included are: 27 rules of thumb for choosing a solar system; 13 exclusive appendices containing a precise set of tools for predicting a building's performance; five transparent sun charts locating the sun's position at any time, during any month, for most U.S. and Canadian locations; computerized analysis of solar heat, specific gravity and thermal conductivity of 160 solids and liquids. Illustrated. \$22.50/\$24.95.

***Perception and Lighting as Formgivers for Architecture (3M316)**
In this 310-page book (1977), William M. C. Lam discusses the working tools of the lighting designer; points out pitfalls and how to avoid them. 55 case study projects are discussed in detail. \$35.75/\$39.50.

Personnel Practices Handbook, Second Edition (2M138)
An 81-page (1978) guideline presenting recommended personnel concepts related specifically to architectural firms. Paperback, \$8/\$10.

***The Photography of Architecture and Design: Photographing Buildings, Interiors and the Visual Arts (3M333)**

In this 240-page book (1977) Julius Shulman shows how to become an architectural photographer. Describes how to obtain the best composition possible by building the right relationship between design elements and structural surfaces. \$22.50/\$25.

***Places for People: Motels, Hotels, Restaurants, and Bars, Third Edition (3M253)**
Emphasizing buildings and facilities for leisure-time use, this 320-page book (1976), edited by Jeanne Davern, Hon. AIA, includes a wide variety of hotels, resorts, lodges, restaurants, clubs, bars, camps, parks, plazas and playgrounds. \$26.75/\$29.50.

***Planning and Design of Airports (3M189)**
460-page book (1975) by Robert Horon-jeff, which takes into account all requirements an airport designer must meet. Includes a summary of the provisions of the Airport and Airway Development Act of 1970. \$33.75/\$37.50.

***Planning Flexible Learning Places (3M118)**
The authors of the 183-page book (1977), Stanton Leggett and others, have combined their knowledge and experience to help the design professional understand the educator's needs and help the educator visualize the kinds of things that can be done to provide a better environment for learning. \$20.25/\$22.50.

***Planning the New Office: From Feasibility Study to Move-in for Managers and Planners (3M390)**
This reference (1978) by Michael Saphier provides a comprehensive overview of the total effort involved in creating a new office. The role of each specialist concerned with office planning projects is described, with concise details of responsibilities, coordination and control. To ensure every step is fulfilled, there is a complete action checklist of everything that may be necessary during the planning process. \$19.50/\$21.50.

***Planning the Office Landscape (3M331)**
Alvin E. Palmer and M. Susan Lewis describe, in this 188-page book (1977), the theoretical aspects of office landscaping and its practical applications from the planning stage through final installation. \$19.50/\$21.50.

***The Poverty of Power: Energy and the Economic Crisis (3M140P)**
314-page book (1976) by Barry Commoner which gives a good background on the economics of energy and natural resources. Paperback, \$2.50/\$2.75.

When Designing a New
or Renovating an Old
SWIMMING POOL

**SPECIFY
PARAGON
QUALITY
EQUIPMENT**

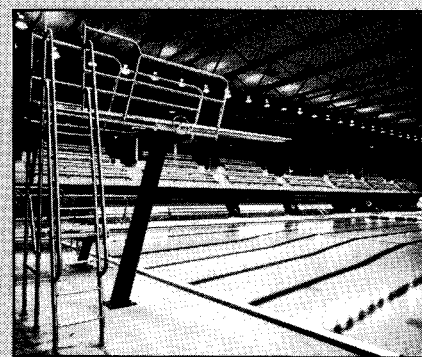

For Detailed Literature or
Design Assistance Call:



KDI Paragon

12 Paulding St., Pleasantville, N.Y. 10570

914/769-6221

See Us in Sweets Under 13.4b/KD

***The Prairie School Tradition: The Prairie Archives of the Milwaukee Art Center (3M417)**

Edited by Brian A. Spencer, AIA, this 304-page book (1979) documents the roots, growth and legacy of the Prairie school and its impact on American architecture. Based on an exhibition organized by the newly constituted Prairie Archives of the Milwaukee Art Center, it represents Frank Lloyd Wright, Adler & Sullivan, Walter Burley Griffin, Marion Mahoney and many others. Illustrated. \$27/\$30.

***Pre-Columbian Architecture of Mesoamerica (3M220)**

336-page book (1973) by D. Heyden and P. Gendrop. Volume 7 of the History of World Architecture series. \$40.50/\$45.

***Primitive Architecture (3M318)**

A 382-page (1975) study by Enrico Guidoni. Volume 12 of the History of World Architecture series. \$40.50/\$45.

***Problem Seeking: An Architectural Programming Primer (3M277)**

Written by William Peña, FAIA, this 202-page book (1977) offers a clear, comprehensive definition of design methodology and process. Tells how to evaluate the programming package, decide on new automated techniques, draw analysis

cards and brown sheets and how to conduct interviews and work sessions. Includes case studies, a matrix checklist of key words and a glossary. \$14.50/\$15.95.

***Professional Construction Management and Project Administration (3M121)**

125-page book (Second edition, 1976) by William B. Foxhall, looking at professional services and who provides them. \$20.25/\$22.50.

***ProFile/The Official AIA Directory of Architectural Firms, 1980 Edition (4M310)**

Edited by Henry W. Schirmer, AIA, this 816-page volume (1980) presents the most detailed description of architectural firms in America. Nearly 8,266 firms are grouped and cross-referenced for the greatest possible convenience. Included are names of the principals of every firm, current and projected work volume by building type and the geographic area of firm's practice. \$85/\$96.

Project Delivery Approaches: An AIA Guide (2M702)

30-page publication (1976) edited by David S. Haviland of the AIA project management systems task force. This guide is essentially a primer and is planned as the nucleus and framework

for AIA development of a series of studies and guidelines for responsive and creative project delivery approaches. \$3.25/\$4.

***Public Relations for the Design Professional (3M455)**

278-page book (1979) by Gerre Jones, Hon. AIA, explores the tools and techniques for planning, researching, implementing and evaluating an effective public relations program that fits the needs of the design profession. Proven how-to's are given on: budgets, exhibits, television, seminars, effective writing for press releases and more. \$19.59/\$21.50.

***Pyramid (3M282)**

80-page text (1975) by David Macaulay follows the intricate step-by-step process of the building of an ancient Egyptian pyramid and the complex of surrounding temples and tombs. \$10.75/\$11.95.

R

***Recycling Buildings (3M265)**

Lavishly illustrated 224-page (1976) collection edited by Elisabeth K. Thompson, FAIA, of the most successful examples of recycled buildings will appeal to ecologists, preservationists and most of

Nature's colors

Use your imagination . . . and our palette of 10 distinctive colors

Choice of finishes to provide the texture you desire. Genuine Aggregate or Terrazzo, naturally beautiful and durable. Quality engineering and vandal resistant features assure dependable performance even in highest traffic locations.

Shown: Model No. RPF-3001, Colorama aggregate with exposed aggregate finish; stainless steel receptor.

Also available: Wall mounted fountains, wheelchair model, custom colors.

Color catalog on request

WILLIAMS

STERN-WILLIAMS CO., INC. • P.O. Box 8004, Shawnee Mission, Kansas 66208



AGGREGATE OR TERRAZZO

Au Forgeron De La Cour-Dieu, Inc.

Astie Art Metal Studio

HAND FORGED IRON ELEGANCE FOR THE DISCRIMINATING BUYER . . .

For two generations Astie Family has supplied fine hand forged ornamental iron throughout France—now throughout the United States.

RESIDENTIAL • INSTITUTIONAL • COMMERCIAL

Antique Reproductions • 211 W. Comstock
Antique Restoration • Dallas, Texas 75208
Sculpture • (214) 742-2000



all to architects, who will find a wealth of imaginative and innovative design ideas. \$25.25/\$27.95.

***Recycling Cities for People: The Urban Process (3M227)**

224-page book (1976) by Laurence Cutler, AIA, and Sherrie Cutler, AIA, offers practical, tested methods for solving urban problems. Topics include balancing old and new developments, efficient use of downtown areas, maximizing benefits of urban highways. \$22.50/\$25.

***Reliance Building Jigsaw Puzzle (4M230)**

400-piece jigsaw puzzle features D. H. Burnham's Reliance Building. One of two in a series titled "Architectural Heritage of Chicago," puzzle is done in sepia from a Hedrich-Blessing photograph. Full history of the structure is on back of box. Completed size is 12¾ x 19 inches. All sales final. \$7.

***Religious Buildings (3M452)**

160-page survey (1979), from the editors of *Architectural Record* magazine, features religious buildings constructed during the past decade. Focusing on the many unique problems of designing for religious use, the articles contain numerous photographs, drawings and plans. The building rationale behind each structure is included. \$22.50/\$24.95.

***Renaissance Architecture (3M122)**

401-page book (1971) by Peter Murray. Volume 1 of the History of World Architecture series. \$40.50/\$45.

***The Restoration Manual (3M115)**

181-page book (1966) by Orin M. Bullock Jr., FAIA, on how to "read" older structures in order to preserve and reconstruct them in a manner compatible with their original design and construction. \$12.75/\$13.95.

***Robie House Jigsaw Puzzle (4M231)**

Frank Lloyd Wright's landmark, the second in "Architectural Heritage of Chicago" series of puzzles is in sepia, from a Hedrich-Blessing photograph. History and importance of the house outlined on back of box. Completed size: 12¾ x 19 inches. All sales final. \$7.

***Roman Architecture (3M286)**

416-page book (1977) by John B. Ward-Perkins. Volume 10 of the history of World Architecture series. \$40.50/\$45.

***Romanesque Architecture (3M190)**

431-page book (1975) by Hans E. Kubach. Volume 5 of the History of World Architecture series. \$40.50/\$45.

***Rose Windows (3M424)**

Extraordinary photographs and informative text in this 144-page book (1979), by Painton Cowen, explore the history,

craft, symbolism and unsurpassed beauty of the rose windows of Gothic cathedrals. Many of the photographs are in full color, to more fully illustrate the beauty of the light as it radiates from the windows. \$20.25/\$22.50.

***Running an Office for Fun and Profit (3M394)**

116-page "how-to" book (1978) by Rosslenn Foote on managing the finances of small design firms written in an easy-to-read and understand format. The options given in this book have been developed because of, and as a result of, financial management seminars given by the author. Good hints for the established office as well as the new. \$13.50/\$15.

S

***The Second Old House Catalogue (3M363)**

Compiled by Lawrence Grow, this 223-page book (1978) is a companion to "The Old House Catalogue." Contains additional information on products, services and suppliers for restoring, decorating and furnishing period houses. \$7.25/\$7.95.

***Simplified Guide to Construction Management for Architects and Engineers (3M239)**

288-page book (1976) by James Gorman covers state-of-the-art CM procedures plus potential developments in today's increasingly complex building projects. Sample contract documents, field reports and project case histories simplify planning and organization of CM services within existing design construction organization. \$14.50/\$15.95.

***Site Planning Standards (3M360)**

A comprehensive, 351-page information source, this book (1977) by Joseph DeChiara and Lee E. Koppelman provides a graphic approach to land use. Includes information on the design process from the predesign stage of data inventory and surveys through the analysis of site conditions and the design of plans with specific site details. \$27/\$29.95.

***So This Is Where You Work! A Guide to Unconventional Working Environments (3M407)**

With text by Charles A. Fracchia and photographs by Marc Kauffman, this 128-page book (1979) shows how office space has been derived from conserving a dilapidated factory or an obsolete church, firehouse, railroad car, barn or even movie theater into an ideal law or dental office, clothing boutique or restaurant. Reviews what reconstruction or redecora-

... and then
your eye lights
on a
WELSBACH.

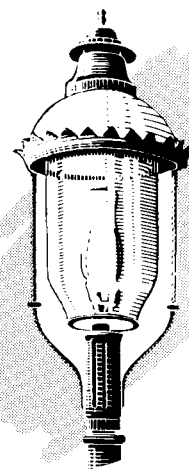

The Boulevard

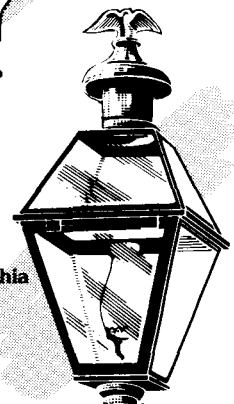

The Philadelphia

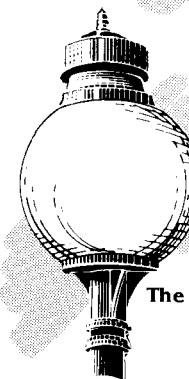

The Coney Island

Enough said . . .
Send for our catalog.



A name you can lean on.

Welsbach Lighting, Inc.
240 Sargent Drive
New Haven, Conn. 06511
(203) 789-1710

tion was done and what employers and employees, clients and customers have to say about the results. \$15.25/\$16.95. Paperback (3M407P), \$9/\$9.95.

***Solar Age Catalog (3M292)**

233-page solar age compendium (1977), by the editors of *Solar Age Magazine*, is packed with information on products, theory and design, resources and individuals involved in the field. Solar professionals have contributed articles on many ways to save heat, passive design and fundamental heat theory, among others. \$7.75/\$8.50.

Solar Architecture (3M234)

This 350-page book (1976), prepared by the Association of Student Chapters/AIA, is an excellent, photo-illustrated reference full of material on the history, components, natural context, research and the future of solar design. A result of the ASC/AIA annual forum held in Tempe, Ariz., November 1975, it is a comprehensive collection of expert presentations and panel discussions. Attendees included many of the nation's leading architects and researchers in the field. \$10.75/\$12.

***Solar Designing (3M271)**

In this 116-page book (1977) James

Lambeth, AIA, provides an in-depth study of his personal experience in designing and building solar homes. With great detail, he discusses siting, materials, construction and climatic data and design skills to take advantage of a complex of environmental variables. \$10.75/\$11.95.

***Solar Dwelling Design Concepts (3M311)**

Prepared by AIA Research Corporation, this 146-page report (1976) is an introduction to solar heating and cooling, funded by HUD to help demonstrate the feasibility of solar technology. Includes: description of solar components and full systems, discussion of environmental factors and design concepts and case studies. Paperback, \$4.50/\$5.

***Solar Energy and Housing Design (3M256)**

By Giffels Associates, Inc., Detroit. Presents a systematic process for selection of solar energy systems applicable to four climatic regions of the continental U.S. and incorporation of these systems into lowrise, multifamily dwellings. Includes a survey of solar collection and storage components. Paperback, 145 pages, \$13.50/\$15.

***Solar Energy: Fundamentals in Building Design (3M303)**

This 304-page book (1977) by Bruce Anderson, AIA, is a comprehensive treatment of the rationale, design and construction of buildings utilizing solar energy. Treats the spectrum of literally hundreds of ways of handling solar energy in building design. \$24/\$26.50.

***Solar Heating Design by the f-Chart Method (3M312)**

200-page book (1977) by William Beckman and others provides a practical method for combining a solar collector to heat either liquid or air, an energy storage unit (a water or pebble bed) and a conventional auxiliary furnace or heater into one economical system to supply the entire heating load. Covers sizing solar space or water heating systems, utilizing the solar collector, storage tank and all associated equipment. \$17.75/\$19.50.

***The Solar Home Book (3M157)**

This 297-page book (1976) by Bruce Anderson, AIA, and Michael Riodan is an unified treatment of energy conservation, passive solar design and the more complex active solar energy systems. Attempts to get architecture and the design of houses away from waste in design, sit-

pool lift

makes swimming barrier free

- Simple to install in above and below ground pools
- Low cost installation
- Easy and safe to operate - No electricity or hydraulics
- Suitable for new or existing pools
- Rugged, corrosion resistant construction

Send today for details to:

mecanoids

U.S.A.:
403 Kennedy Blvd., Somerdale, N. J. 08083

HEAD OFFICE:
5200 Dixie Road, Suite 205, Mississauga, Ontario, Canada L4W 1E4

Telephone: (416) 625-1733
(Call Collect)

FACULTY POSITIONS OPEN

KING FAISAL UNIVERSITY
COLLEGE OF ARCHITECTURE AND PLANNING
DAMMAM, SAUDI ARABIA

New positions for faculty at all levels have been created for the academic year 1981-1982 in the following areas:

ARCHITECTURE	URBAN/REGIONAL PLANNING
ENGINEERING SCIENCES	BUILDING TECHNOLOGY
LANDSCAPE ARCHITECTURE	MATHEMATICS/PHYSICS

PREREQUISITES: Ph.D., M.A. or equivalent degree; practical and/or teaching experience; membership in professional organization.

SALARIES: Competitive with western academic institutions.

BENEFITS: Include free furnished accommodations, educational allowance for four children, air tickets to and from Saudi Arabia once a year for husband, wife and two children, 60-day summer holiday, no Saudi income tax.

Language of instruction is English. Positions begin in September 1981.

Please send complete resume, including daytime telephone numbers, and a listing of three references to:

DEAN AHMED FARID MOUSTAPHA
COLLEGE OF ARCHITECTURE AND PLANNING
KING FAISAL UNIVERSITY
C/O SAUDI ARABIAN EDUCATIONAL MISSION
2425 WEST LOOP SOUTH
HOUSTON, TEXAS 77027

ing and use of materials and toward energy-conscious techniques. \$8.75/\$9.50.

***Space Planning: Designing the Office Environment (3M250)**

160-page book (1976) by Lila Shoshkes written for architects and clients alike. A survey of office design techniques and procedures. Covers the design process; user needs analysis, data gathering, all aspects of office environment, such as light, acoustics, power, furniture and safety. Implications of computer utilization also discussed. \$19.50/\$21.50.

***Specifications for Commercial Interiors: Professional Liabilities, Regulations, and Performance Criteria (3M457)**

S. C. Reznikoff brings together critical information on health and safety regulation, liability and specification considerations in an interior design practice. This 304-page book (1979) examines six regulatory areas, relevant interior subsystems and the specification technology peculiar to interior design. Of particular importance is the extensive glossary. Illustrated. \$26.75/\$29.50.

Standardized Accounting for Architects (2M705)

First published in 1950, this 153-page revised manual (1978) brings the accounting system presented into conformity with the entire AIA financial management system. It is designed to provide a simple recordkeeping procedure that will yield appropriate financial data for routine tax and accounting purposes and for monitoring the operations of a firm. The double-entry system of bookkeeping employed allows the use of either the cash basis or the accrual basis for accounting. Subjects covered include: basic accounting principles, standardized accounting procedures, the basis system and the cash journals, adjusting and closing cash journal, and payroll and project expense accounting. A glossary of terms is provided. \$16/\$20.

***Summer Places (3M379)**

Written by Brenden Gill, with photographs by Dudley Witney, this 224-page book (1978) is an affectionate sometimes nostalgic look at the places where the rich and not-so-rich have long spent their summers—whether it be a cut-stone mansion in Newport, R.I., or a rustic split-log cabin in the Colorado Rockies. \$31.50/\$35.

***Sun Angles for Design (4M362)**

Robert Bennett, author of this 77-page book (1978), presents sun angle data in an understandable and easily usable form. Charts simulate the sun's motion across the sky and show its position for any time

of the day and any day of the year. Architectural applications of the charts include shadow casting, shadow mapping and solar site analysis. Paperback, \$6.50/\$7.

***Sun/Earth: How to Apply Free Energy Sources to Our Homes and Buildings (3M150)**

232-page book (1976) by Richard L. Crowther, AIA, that presents in non-technical language a survey of architecture and its relation to the natural environment and shows the reader how to create comfortable living situations while conserving fossil fuels. \$8.25/\$8.95.

***Supermannerism: New Attitudes in Post-Modern Architecture (3M306)**

This 354-page book (1977) by C. Ray Smith, AIA, is concerned with the attitudes that provide the contextual background of design and architecture in America today. It covers the revolution against the "modern" style and the development of the current period in architecture and design now referred to as "postmodern." \$9/\$9.95.

***Survey of Passive Solar Buildings (4M264)**

Prepared by AIA Research Corporation for HUD, this 177-page publication (1978) documents the state of the art in passive solar design in the U.S. It offers a working definition and a basic understanding of a number of existing applications of passive solar designs. A reference bibliography is included. \$8.

T

***Ten by Warren Platner (4M276)**

224-page volume (1975) presents 10 projects by Warren Platner, FAIA, one of the nation's best-known architects, interior designers and designers of furniture. \$15.

***Theater Design (3M281)**

George Izenour, in this 480-page book (1977), introduces general terminology, types of theater design, detailing and defining auditoriums, stages, sight and hearing lines, and the basics necessary to an appreciation of theater design. Concert halls, with their specific acoustical characteristics, are covered. \$112.50/\$125.

***Time-Saver Standards for Architectural Design Data (3M181)**

1,042-page handbook (1974) by John Hancock Callender containing technical design data. Particularly useful for the preliminary stages of the design process. \$40.25/\$44.50.

***Time-Saver Standards for Building Types (3M173)**

1,065-page handbook (1973) by Joseph DeChiara and John Hancock Callender,

including basic planning design data from a wide variety of sources, systematically presented for 10 major building types. \$42.75/\$47.50.

***Toolchest: A Primer of Woodcraft (3M288)**

This 48-page book (1973) by Jan Adkin is a rare work of craftsmanship; more than a primer, it is a celebration of the basic skills and tools a handworker needs. Illustrations are clean and sharp and effective as a freshly whetted chisel. For ages 10 and up. \$6.25/\$6.95.

***A Treasury of Contemporary Houses (3M364)**

208-page idea book (1978), edited by Walter F. Wagner Jr., AIA, presents innovating design concepts that fulfill a wide range of needs. Organized by form, these houses cover a variety of sites and cost levels. Shows how architects and clients can work together to create a successful custom-designed house. \$19.75/\$21.95.

***Tree Houses: An Illustrated Essay on the Aesthetic & Practical Aspects of Arboreal Architecture (3M413)**

Prepared by the staff of the Green Tiger Press, this 48-page book (1975) runs the gamut of information about tree houses. Includes: selection of the tree, access to the house, furnishings, building codes and much more. Ideal for children 8 to 12 years of age. Illustrated. Paperback, \$3.50/\$3.95.

***Tropical Architecture (3M398)**

Written by C. P. Kukreja, an architect from New Delhi, India, this 134-page book (1978) deals with both the theoretical and practical aspects of planning buildings in the tropics. Detailed coverage is given to the influence of sun, wind, landscaping, local building materials, esthetic considerations, construction techniques and the research in climate control. \$17.75/\$19.50.

U

***Underground (3M283)**

This 112-page book (1976) is David Macaulay's exploration of the complicated below-ground life-support systems: water, electricity, gas, telephone. Traces the structure of skyscrapers, follows sewage and drainage lines and explains the construction of a subway. \$10.75/\$11.95.

Uniform Construction Index: A System of Formats for Specifications, Data Filing, Cost Analysis, and Project Filing (2M200)

A comprehensive data filing format

(1972) for design and construction information; a format for filing project correspondence; the CSI format for construction specifications; an estimator's cost analysis format, and a key word index interrelated with the specifications and data filing formats. \$9.75/\$12.

***The Use of Color in Interiors, Second Edition (3M372)**

160-page detailed, problem-solving guide (1979) to the successful use of color, written by the late Albert O. Halse, AIA. Discusses the basics of color theory, including various methods used to achieve specific objective effects of light and the psychological effects of color. Illustrated. \$26.75/\$29.50.

***The Use of Land (3M175)**

318-page report (1974) of the Rockefeller Brothers Fund task force on land use and management. \$3.50/\$3.95.

V

***Vacation Houses, Second Edition (3M296)**

244-page (1977) book, edited by Jeremy Robinson and Martin Filler, presents outstanding designs of the preceding five

years. Sites, sizes and budgets are included. For the architect and his client. \$22.50/\$24.95.

***Visual History of 20th-Century Architecture (3M165)**

The development of contemporary architectural styles between 1900 and 1970 are outlined pictorially in this 304-page book (1973) by Dennis Sharp. \$27/\$29.95.

W

***Water in Landscape Architecture (3M367)**

Illustrated, 128-page book (1978), by Craig S. Campbell, deals in substantial detail with the technical as well as the esthetic principles of fountain design. Covers basic hydraulic principles, practical limitations, environment and available equipment. \$14.50/\$15.95.

***Windows (3M406)**

Val Clery's illustrated 168-page book (1979) reveals windows that are encrusted with history, look into the future, jealously guard privacy or strive to dissolve barriers. All give glimpses of private worlds, subjects for wonder and contemplation. \$13.50/\$14.95. Paperback (3M406P), \$9/\$9.95.

Working in Government: A Profile Study of the Architect as a Public Employee (2M712)

Prepared by the AIA architects in government committee (1978), the information presented in this report is intended to give the general public a better understanding of the various functions performed by architects in government; to give educators a clearer view of educational needs and opportunities, and government administrators an opportunity to make comparative assessments of architects in various agencies and at various levels of government. Developed from a survey of more than 2,000 architects in government conducted in 1976, it provides a comprehensive profile of those persons practicing as architects in the public sector. \$5/\$6.

***The Writings and Sketches of Matthew Nowicki (4M280)**

58-page book (1973) by Bruce H. Schafer contains the work of an educator/architect. Though he was never fully acknowledged during his lifetime, the design philosophy of this staunch humanist is a synthesis of several trends in modern architectural thought. \$8. □

BOOKLIST

AIA

INTERIORS

***Houses Architects Live In (3-M302)**

By Barbara Plumb. Presents brilliantly designed houses and apartments from modest to lavish, all emphasizing ingenious ways of combining beauty and practicality. All have interiors alive with ideas suitable for adaptation to all types of living situations. The author reviews concerns that determine architects' choices in designing their own environments, and notes how they individually deal with such matters as situation, space, scale, balance, color, light, and all factors involved in creating a home that meets their needs and interests. Hardcover, 168 pages, 168 color illustrations (1977). \$17.95 Non-member, \$16.15 AIA member.

DESIGN

*** Pedestrians Only: Planning, Design and Management of Traffic-Free Zones (3-M278)**

By Roberto Brambilla and Gianni Longo. This appraisal of traffic-free zoning in 20 European and North American cities provides, for the first time, a comprehensive study of the complex process of eliminating all the noise, pollution, and turmoil from urban spaces. By summarizing and analyzing what has been achieved, the book offers a resource to guide future efforts to make cities more habitable. A compendium of over 70 American pedestrian malls completes the thoroughly researched text. Hardcover, 208 pages, 250 illustrations (1977). \$24.95 Non-member, \$22.45 AIA member.

ENERGY

***Solar Dwelling Design Concepts (3-M311)**

Prepared by AIA Research Corporation. This introduction to solar heating and cooling was prepared under contract to the Department of Housing and Urban Development as part of HUD's effort to demonstrate the feasibility of solar technology. A short history of solar applications, description of solar components and full systems, discussion of environmental factors and design concepts, and case studies make up this comprehensive overview of current concepts in solar design. Soft-cover, 146 pages, profusely illustrated (1976). \$5.00 Non-member, \$4.50 AIA member.

PRACTICE AIDS

***Creative Communications For a Successful Design Practice (3-M300)**

By Stephen A. Kliment. An invaluable tool for design professionals who want to develop skills and techniques needed to communicate effectively with present and potential clients, the media, and the public. More than a reference, here is a thorough course dealing with everything from letters to the annual report, slide presentations, speeches, press relations, and why and how to write a book. Hardcover, 192 pages, 200 illustrations (1977). \$22.50 Non-member, \$20.25 AIA member.

GOVERNMENT

Working in Government: A Profile Study of the Architect as a Public Employee (2-M712)

Prepared by AIA's Architects in Government Committee. The information presented in this report is intended to give the general public a better understanding of the various functions performed by architects in government; to give educators a clearer view of educational needs and opportunities; and government administrators an opportunity to make comparative assessments of architects in various agencies and at various levels of government. Developed from a survey of over 2,000 architects in government conducted in 1976, it provides a comprehensive profile of those persons practicing as architects in the public sector. Softcover, 40 pages (1978). \$5.00 Non-member, \$4.00 AIA member.

TO ORDER

Order from: Manager, Publications Marketing, 1735 New York Avenue, N.W., Washington, D.C. 20006.

Make checks payable to the American Institute of Architects. District of Columbia residents add 5 percent sales tax.

For first class, air mail, special delivery, air express handling add 20 percent to total amount of order.

Foreign orders must include postage in the amount of 20 percent added to total amount of order. Check or money order must be payable in U.S. dollars.

The American Institute of Architects introduces an Unusual Addition to Its Line of Practice Aids—

Preventive Medicine for Headaches

The traumatic headaches owners get from uninsured adversity can be very contagious. The architect of a project struck by uninsured fire, or casualty, or unbonded contractor default may suffer embarrassment, economic loss, and countless hours spent in the notably unpleasant task of sorting out the mess.

Having recognized that sufficient construction bonding and insurance are in your own best interest as well as your client's, however, you still have a major problem. Insurance and bonding is a complicated business, full of technical concepts and esoteric terminology. What aid can an architect possibly give to an owner struggling through the informational maze of bonds and insurance?

AIA Has the Help You Need. The definitive Second Edition of *Construction Bonds and Insurance Guide*, by Bernard B. Rothschild, FAIA, explains all the who's, what's, when's, where's and why's of

construction-related bonds and insurance, as required by AIA Document A201, General Conditions of the Contract for Construction. It provides invaluable guidance to—and mutual understanding of respective responsibilities among—owners, insurance advisors, and architects.

The *Guide* won't make you an insurance expert. Indeed, it stresses the importance of an owner's seeking the counsel of a qualified insurance professional. What it *will* do is define your proper role, as an architect, in relation to construction bonds and insurance, and give you a solid working knowledge of protective requirements and options.

Its handy looseleaf format allows you to augment the descriptive information provided with additional notes and documents from your own practice.

A Revolutionary Combination of Proven Ingredients. For the first time anywhere, the *Guide* brings together:

- **Explanations* of how construction bonds and insurance requirements are met, with special reference to widely used AIA Documents.
- *A comprehensive *glossary* providing clear and concise definitions of relevant insurance industry terms.
- **Samples* of the many forms actually used by companies insuring construction projects.

The *Guide* explains how to start a project off on the right track by initiating the Owner's Instructions for Bonds and Insurance (AIA Document G610), and how these matters are dealt with in the

General Conditions of the Contract for Construction (A201) and other AIA Documents.

The discussion of construction bonds covers bid or proposal bonds, performance bonds, labor and material payment bonds, completion bonds, and maintenance bonds.

The *Guide's* treatment of insurance details workers' compensation insurance, employer's liability insurance, the numerous specific elements of general liability insurance, and various endorsements to property insurance.

Included throughout these discussions are explanations of how levels of coverage are determined and paperwork is performed, hints about special areas of vulnerability the architect should be aware of, and notes about the considerations that apply to the architect involved in "design-build" project delivery of construction management.

In short, timely consultation of *Construction Bonds and Insurance Guide* will save everyone involved in a project from a whole range of paralyzing headaches.

Recommended Dosage: At Least One Copy Per Office. Having made the *Guide* available to your clients and their insurance advisors, you may find that the volume is constantly "on loan." Why not buy an extra copy for office use only?

Order your copies now from Publication Sales, The American Institute of Architects, 1735 New York Avenue, N.W., Washington, D.C. 20006, supplying the following information: firm name, correct mailing address, name of person to receive order, and AIA chapter affiliation, if applicable.

Indicate number of copies you wish to order, and include payment with order (D.C. residents add 5% sales tax). Make check payable to AIA. Refer to catalog #2M163 — Construction Bonds and Insurance Guide. \$16 each to AIA member. \$20 each to non-member.

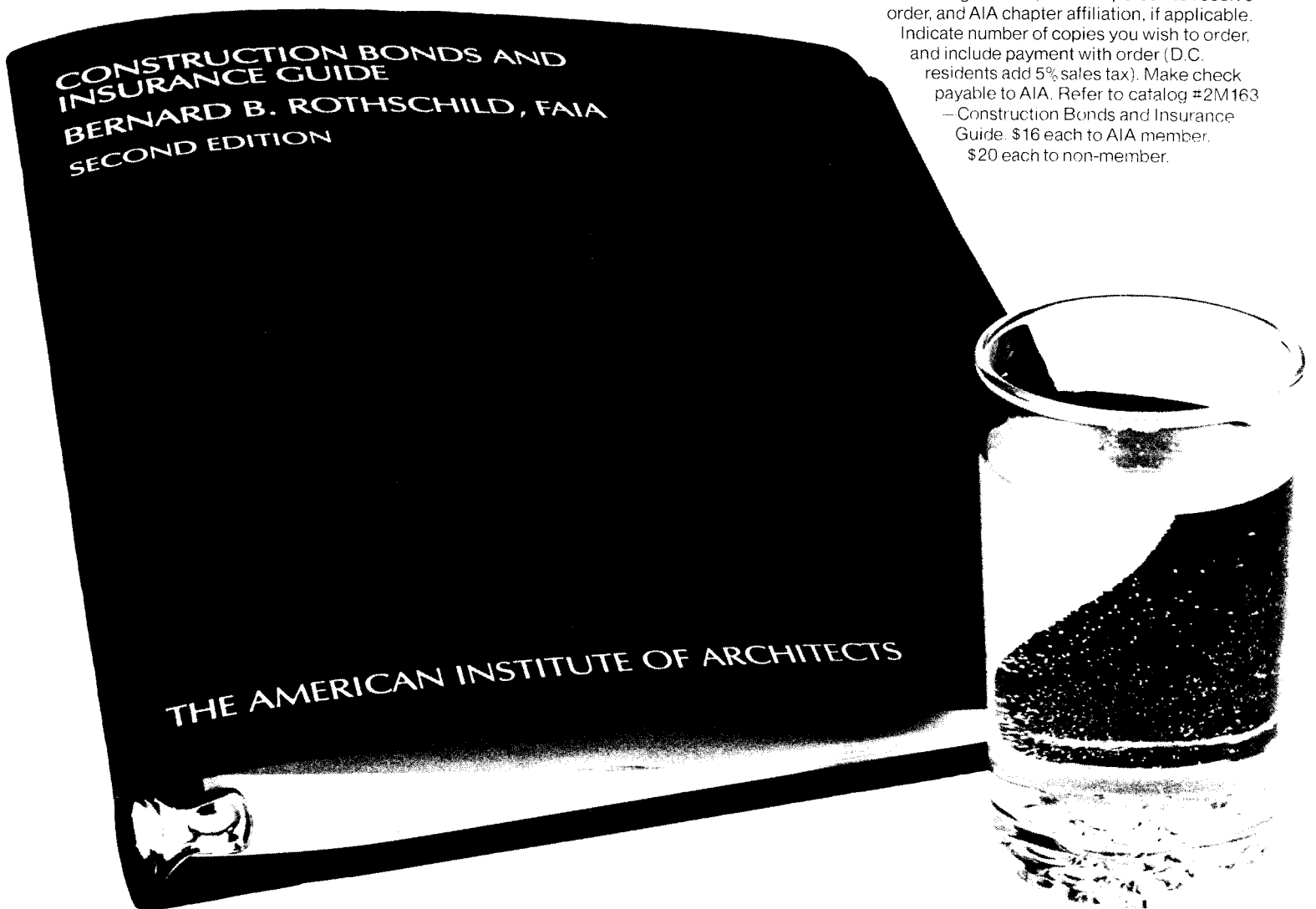

The following firms and AIA component offices are official distributors for AIA contracts and forms. If you reside in one of the states marked with an asterisk (*), your document order should be directed to your authorized distributor.

***Alabama**

Birmingham

Birmingham Chapter
1105 S. 20th St. 35205
(205) 933-1934

Mobile

Bidgood Stationery Co.
68 Saint Francis St. 36601
(205) 433-3731
Mobile Chapter
c/o Southern Blueprint and Supply, Inc.
2200 Government St. 36606
(205) 473-8667

Montgomery

Montgomery Chapter
415 Washington Ave. 36104
(205) 264-3037

Alaska

Anchorage

Alaska Chapter Document Service
2515 A St. 99507
(907) 276-2834

Arizona

Phoenix

Arizona Society of Architects
1121 N. Second St. 85004
(602) 257-1992

Tucson

Southern Arizona Chapter
4901 E. Fifth St. #206 85711
(602) 881-1777

Arkansas

Fort Smith

Fort Smith Section
1888 Building
302 N. Sixth Ave., Suite A 72901
(501) 782-1051

Little Rock

Shepherd's
603 W. Markham St. 72201
(501) 375-6937

***California**

Long Beach

Cabrillo Chapter
121 Linden Ave. 90802
(213) 432-9817

Los Angeles

Los Angeles Chapter
Pacific Design Center
8687 Melrose 90069
(213) 659-2282

Oakland

East Bay Chapter
315 14th St. 94612
(415) 893-6834

Sacramento

Central Valley Chapter
1025 19th St., Suite 8 95814
(916) 444-3658

San Diego

San Diego Chapter
233 A St., Suite 207 92101
(714) 232-0109

San Francisco

Northern California Chapter
790 Market St., Third Floor 94102
(415) 362-7397

Santa Ana

Orange County Chapter
Mercantile Building
3850 S. Plaza Drive 92704
(714) 557-7796

Santa Barbara

Santa Barbara Chapter
P.O. Box 2381 93120
(805) 965-6307

Santa Clara

Santa Clara Valley Chapter
1333 Lawrence Expressway 95051
(408) 249-1515

***Colorado**

Boulder

Ridgway's
839 Pearl St. 80302
(303) 444-3390

Denver

Capitol Hill Blueprint Service
1634 18th St. 80202
(303) 892-9593
Colorado Society of Architects
1420 Larimer Square 80202
(303) 629-0759

***Connecticut**

East Hartford

Cleaveland Legal Blank Service Inc.
66 Connecticut Boulevard 06108
(203) 289-5446

Farmington

Crest Blueprint Service Inc.
220 Farmington Ave. 06032
(203) 677-8817

New Haven

Connecticut Society of Architects
85 Willow St. 06511
(203) 865-2195

Delaware

Wilmington

Wilmington Blueprint Service
2704 W. Third St. 19805
(302) 652-3364

***Florida**

Fort Lauderdale

Broward County Chapter
519 N.E. Third Ave. 33301
(305) 763-7216

Jacksonville

A. R. Cogswell Blueprint
738-800 N. Myrtle Ave. 32204
(904) 356-4271
Jacksonville Chapter Bookworks
One Independent Square
Independent Life Building 32202
(904) 355-8533

Miami

Florida South Chapter
P.O. Box 647 33145
(305) 221-5615

Tallahassee

Florida Association
117 W. College 32302
(904) 222-7590

***Georgia**

Albany

Dougherty Blueprint & Supply Co.
420 N. Cleveland St. 31702
(912) 435-5727

Atlanta

Ivan Allen Co.
P.O. Box 1712 30301
(404) 521-0800
Atlanta Blueprint & Photo Reproduction
1052 Peachtree St. 30309
(404) 873-5911
Atlanta Chapter Arch. Book Center
Peachtree Center, Cain Tower Lobby
229 Peachtree St. N.E. 30303
(404) 524-3877

Georgia Blueprint Co.

119 Luckie St. N.W. 30303
(404) 524-8881

Columbus

Siegel Reproduction & Supply Co.
1200 13th St. 31902
(404) 324-1373

Savannah

Savannah Blueprint Co.
11 E. York St. 31401
(912) 232-2162

Sources for AIA Contracts and Forms

*Hawaii

Honolulu
Hawaii Society of Architects
1136 Union Street Mall #902 96813
(808) 538-7276

Idaho

Boise
Idaho Chapter
842 La Cassia Drive 83705
(208) 345-1730

*Illinois

Chicago
Chicago Chapter
310 S. Michigan Ave., #210 60604
(312) 663-4111
Moline
Tri-City Blueprint Co.
1615 Third Ave. 61265
(309) 764-2478

*Indiana

Indianapolis
Architectural Center/Indiana Society
of Architects
148 N. Delaware 46204
(317) 634-3871
Marbaugh Engineering Supply
121 W. North St. 46204
(317) 632-4322

*Iowa

Des Moines
Iowa Chapter
512 Walnut St. 50309
(515) 244-7502

*Kansas

Topeka
Kansas Society of Architects
724 Kansas Ave. 66603
(913) 357-5308
Wichita
City Blueprint Inc.
1200 E. Waterman 67201
(316) 265-6224

*Kentucky

Lexington
Lynn Blue Print & Supply Co.
327 E. Vine St. 40507
(606) 255-1021
Louisville
Central Kentucky Chapter
c/o Becky Biesel
2239 Milvale Road 40205
(502) 459-4441
St. Matthews Blueprint & Supply Co.
131 St. Matthews Ave. 40207
(502) 895-2467

*Louisiana

Baton Rouge
Louisiana Architects Association
830-A North St. 70802
(504) 387-5579

Maryland

Baltimore
Building Congress and Exchange
2301 N. Charles St. 21218
(301) 235-4161
Lucas Brothers Inc.
7700 Port Capital Drive 21227
(301) 685-3000

*Massachusetts

Boston
Boston Blueprint Co., Inc.
777 Boylston St. 02116
(617) 267-2490
Boston Society of Architects
320 Newbury St. 02115
(617) 267-5175
Hobbs & Warren Inc.
80 Summer St. 02101
(617) 542-7947
Andrew T. Johnson Co.
15 Tremont Place 02108
(617) 742-1610
B. L. Makepeace Inc.
1266 Boylston St. 02215
(617) 267-2700
Woburn
Charrette Corporation
31 Olympia Ave. 01801
(617) 935-6121

*Michigan

Detroit
Michigan Society of Architects
553 E. Jefferson Ave. 48226
(313) 965-4100
Grand Rapids
Bixby Office Supply Co.
357 36th St. S.E. 49508
(616) 452-3213

*Minnesota

St. Paul
Architectural Book Center/MSA
402 Northwestern Skyway Building 55101
(612) 227-0761

*Mississippi

Jackson
Mississippi Chapter
P.O. Box 12515 39211
(601) 981-9327

Missouri

Kansas City
Kansas City Chapter
20 W. Ninth St. 64105
(816) 221-3485

St. Louis

St. Louis Chapter
919 Olive St. 63101
(314) 621-3484

MontanaBillings*

Montana Chapter
P.O. Box 20996 59104
(406) 259-7300

NebraskaOmaha*

Nebraska Society of Architects
1910 S. 44th St. 68105
(402) 556-8506
Standard Blue Print Co.
10011 J St. 68127
(402) 592-5900

Nevada*Las Vegas*

Construction Notebook
3599 S. Polaris 89103
(702) 876-8660

Reno

Northern Nevada Chapter
Document Service
c/o Raymond Hellman, AIA
137 Vassar St., Suite 8 89502
(702) 329-7049

New Hampshire*Concord*

New Hampshire Chapter
43 S. State St. 03301
(603) 228-1231

New JerseyCamden*

Allen Reproduction Co.
800 Market St. 08102
(609) 365-5787

Woodbridge

New Jersey Society of Architects
One Thousand Route Nine 07095
(201) 636-5680

New MexicoAlbuquerque*

New Mexico Society of Architects
67 First Plaza/Galleria 87102
(505) 842-8744

New YorkAlbany*

Eastern New York Chapter
13 Northern Boulevard 12210
(518) 465-3191

New York

New York Chapter
457 Madison Ave. 10022
(212) 838-9670

Old Westbury

Long Island Chapter
c/o ASC/AIA
New York Institute of Technology
Wheatley Road 11568
(516) 249-7370

Rochester

Rochester Chapter
130 Spring St., Second Floor 14608
(716) 232-7650

North CarolinaCharlotte*

Pound & Moore
304 S. Tryon St. 28201
(704) 375-7751
Southern Photo Print Supply Co.
201 Rampart St. 28200
(704) 332-2154

Durham

Southern Photo Print Supply Co.
115 E. Parrish 27701
(919) 682-5098

Fayetteville

Southern Photo Print Supply Co.
314 E. Russell St. 28301
(919) 483-4909

Greensboro

Southern Photo Print Supply Co.
1639 Spring Garden St. 27402
(919) 274-1541

High Point

Southern Photo Print Supply Co.
340 N. Wrenn St. 27260
(919) 882-3127

Raleigh

North Carolina Chapter
115 W. Morgan St. 27601
(919) 833-6656

Raleigh Blue Printers
213 W. Martin St. 27601
(919) 832-2841

Wilmington

Southern Photo Print Supply Co.
923 N. Third St. 28401
(919) 762-9617

North Dakota*Fargo*

Mathisons
1213 Northern Pacific Ave. 58102
(701) 232-8971

OhioCincinnati*

Cincinnati Chapter
602 Main St., Suite 1114 45202
(513) 421-2657

Cleveland

City Blueprinting Co.
1937 Prospect Ave. 44115
(216) 241-7344

Columbus

Architects Society of Ohio
37 W. Broad St. 43215
(614) 221-6887

Dayton

Dayton Blueprint Co.
222 N. Saint Clair St. 45402
(513) 223-2272

Toledo

Toledo Blueprint and Paper Co.
617 Adams St. 43604
(419) 243-7224

OklahomaOklahoma City*

Oklahoma Chapter
405 N.W. 15th St. 73103
(405) 525-7897

Tulsa

Tulsa Chapter
2250 E. 49th St., Suite 12 74105
(918) 749-0516

OregonPortland*

Portland Chapter
519 S.W. Third Ave. 97204
(503) 223-8757
Stevens-Ness Law Publishing
916 S.W. Fourth Ave. 97204
(503) 223-3139

PennsylvaniaHarrisburg*

Harrisburg Blueprint
204 Locust St. 17101
(717) 232-3096
Pennsylvania Society of Architects
P.O. Box N 17105
(717) 236-4055

Philadelphia

Philadelphia Chapter
117 S. 17th St. 19103
(215) 569-3186

Pittsburgh

Pittsburgh Chapter
1612 Benedum-Trees Building 15222
(412) 471-9548

Scranton

Reynolds Brothers Inc.
138 N. Washington Ave. 18503
(717) 342-8205

Williamsport

Plankenhorn Stationery Co.
144 W. Fourth St. 17701
(717) 326-2676

Rhode IslandProvidence*

Rhode Island Chapter
55 Canal St. 02903
(401) 272-6418

South Carolina*Charleston*

Charleston Blueprint & Supply
284 E. Bay St. 29402
(803) 722-1617

Columbia

Capital Blueprint Co.
2730 Millwood Ave. 29205
(803) 254-2561

Florence

Pee-Dee Blueprint Co.
484 W. Palmetto St. 29501
(803) 669-5341

Greenville

Piedmont Printmakers & Supply
353 W. McBee Ave. 29602
(803) 233-5371

South Dakota*Rapid City*

Rapid City Builders and Exchange
907 Jackson Boulevard 57701
(605) 343-5252

Sioux Falls

Mathisons
115 S. Indiana 57701
(605) 232-8971
South Dakota Society of Architects
2204 S. Holly Ave. 57105
(605) 338-2073

TennesseeKnoxville*

Knoxville Blueprint & Supply Co.
622 Leroy Ave. 37921
(615) 525-0463

Memphis

Builders Exchange of Memphis
642 S. Cooper St. 38104
(901) 272-7495

Nashville

Nashville Blueprint & Supply
908 Division St. 37203
(615) 259-2230
Tennessee Society of Architects
517 Union St. 37219
(615) 256-2311

TexasAustin*

Texas Society of Architects
2121 Austin National Bank Building 78701
(512) 478-7386

Dallas

Dallas Chapter
2800 Routh, Suite 141 75201
(214) 748-4264

Houston

Houston Chapter
3121 Buffalo Speedway
Suite 404 77098
(713) 629-0191
Ridgway's
4102 Greenbriar 77098
(713) 782-8580

San Antonio

San Antonio Chapter
306 N. Presa, Suite 8 78205
(512) 226-4979
Paul E. Anderson Co.
3485 Fredericksburg Road 78201
(512) 743-8111

UtahSalt Lake City*

Utah Society of Architects
555 E. South Temple 84102
(801) 532-1727

Vermont*Charlotte*

New England Book Service 05445
(802) 425-2461

Virginia*Charlottesville*

Mint Printing & Supply Co.
510 E. Westfield Road 22901
(804) 973-4408

Norfolk

Henry Eagleton Co.
430 Bousch St. 23510
(804) 622-1881

Richmond

R. R. Sharpless Co., Inc.
7 E. Cary St. 23220
(804) 643-8491
Virginia Reproduction & Supply
9 W. Cary St. 23220
(804) 643-9116

WashingtonSeattle*

Seattle Chapter
311½ Occidental Ave. S. 98104
(206) 622-4938

Spokane

J. A. Gendron Co.
1012 N. Washington 99201
(509) 326-4490

West Virginia*Huntington*

Trasco
826 Sixth Ave. 25701
(304) 529-1388

South Charleston

West Virginia Society of Architects
1016 Knob Way 25309
(304) 768-6675

WisconsinMadison*

Wisconsin Society of Architects
615 E. Washington Ave. 53703
(608) 257-8477

The producers of products, systems, materials and supplies offer various resources, including publications, slide shows, films and design and layout services. Items are free unless a price is indicated. This list was put together from responses received from supplier firms. The contents, in edited form, are solely the suppliers'; inclusion here is neither an endorsement nor a commentary on the substance of the resources. The list is organized according to the Uniform Construction Index in 16 categories of product areas.

UCI 1: General Requirements

AM Bruning

"Copiers for Architect's Drawings" describes complete range of whiteprinters in all three diazo processes: PD, Ammonia and Copyflex. Also available are "Sensitized Materials for Architect's Copiers" and "Drawing Media."

Contact Advertising Manager, AM Bruning, 1834 Walden Office Square, Schaumburg, Ill. 60196.

American-Standard

Offers plumbing fixture elevation templates, \$1.50, and metric scale plumbing fixtures templates, \$2.

Contact American-Standard, P.O. Box 230, New Brunswick, N.J. 08903.

Charrette

258-page catalog describes office materials, equipment and furniture for the architect and professional design office. Contact Charrette, 21 Olympia Ave., Woburn, Mass. 01801.

Home-Tech Publications

"Restoration and Renovation Cost Estimator" (4th ed.) is a labor and materials cost manual for restoration, renovation and repair of residential properties. A local area cost modification index and item-by-item quarterly updates are included. \$28.80.

Contact Home-Tech Publications, 7315 Wisconsin Ave. N.W., Washington, D.C. 20014.

Kreonite, Inc.

Brochure available on the company's

photographic and graphic arts laboratory systems and equipment. Also offered is a laboratory design service.

Contact Kreonite, Inc., 715 E. 10th St., P.O. Box 2099, Wichita, Kan. 67201.

Kroy Industries Inc.

Design products for architects, engineers, draftsmen and graphic artists, such as the company's line of electric erasers, lead sharpeners and Appli-K transfer film, are described in brochure. Literature is also available on all KroyType lettering machines.

Contact Jane Brown, Communications Specialist, Kroy Industries Inc., 1728 Gervais Ave., P.O. Box 43716, St. Paul, Minn. 55164.

Talk-A-Phone Co.

Brochures describe the company's line of intercoms for office, industry, home and apartment.

Contact Talk-A-Phone Co., 5013 N. Kedzie Ave., Chicago, Ill. 60625.

Victor O. Schinnerer & Co., Inc.

Brochures describe special features of the CNA professional liability insurance program for architects and engineers and the project policy insurance program. Also available is subscription information for "Guidelines For Improving Practice," a series of loss prevention articles for design professionals, and information on professional liability seminars.

Contact Victor O. Schinnerer & Co., Inc., 5028 Wisconsin Ave. N.W., Washington, D.C. 20016.

UCI 2: Site Work

Continental Custom Bridge Co.

Brochure describes prefab, steel bridges, stairs and landings.

Contact Continental Custom Bridge Co., Route 5, Box 178, Alexandria, Minn. 56308.

Conwed Corporation

Will supply literature on Hydro Mulch fibers, a turf establishment method for commercial and industrial construction projects. Information is also available on how plastic netting aids in erosion control.

Contact Sheila A. Katusky, Advertising Department, Conwed Corporation, P.O. Box 43237, St. Paul, Minn. 55164.

Neenah Foundry Co.

"Cast Iron Tree Grates" is a catalog detailing over 65 types/sizes of grates that allow water to reach roots in paved areas, plus five guard designs.

Contact J. M. Meyer, Marketing Service Manager, Neenah Foundry Co., P.O. Box 729, 2121 Brooks Ave., Neenah, Wis. 54956.

UCI 3: Concrete

Bomanite Corporation

"The Best Impression You Can Make in Concrete" describes the company's colored and imprinted concrete. The "Bomanite Creative Concrete Kit" includes color chart and transparent overlay of available patterns. Bomacron textured concrete is described in a brochure. Also available is a brochure describing Grasscrete, reinforced concrete paving with holes in which grass grows.

Contact Bomanite Corporation, 81 Encina Ave., Palo Alto, Calif. 94301.

Concrete Reinforcing Steel Institute

Offers the 4th edition of the 850-page *CRSI Handbook*, \$29, the 256-page *CRSI Reinforced Concrete Fire Resistance*, \$19.50 and the *Structural Design Guide to ACI Building Code*, \$24.95. The CRSI direct mail list provides case history reports, PSI reports and the Design Award Winners Brochure. Also available on loan are two slide shows for in-house training programs and for students. One is a visual tour through a reinforcing steel mill and fabricating shop and the other is a collection of architectural concepts illustrated by previous design award winners.

Contact Victor A. Walther Jr., Vice President, Marketing and Promotion, Concrete Reinforcing Steel Institute, 180 N. La Salle St., Chicago, Ill. 60601.

Harding & Cogswell Corporation

Offers literature packets describing the firm's line of limestone wall panels.

Contact Harding & Cogswell Corporation, P.O. Box 714, Bedford, Ind. 47421.

Perlite Institute Inc.

12-page catalog contains technical data and guide specifications for Perlite insulating concrete roof deck constructions. Includes information on physical properties, roof deck system thermal values, fire ratings, roof drainage and architectural details.

Contact Perlite Institute Inc., 45 W. 45th St., New York, N.Y. 10036.

Riverside Cement Co.

Design manual includes individual brochures on cast-in-place, precast, masonry, surface bonding, stucco, terrazzo and swimming pools with specifications. Contact Jim Bower, Riverside Cement Co., P.O. Box 832, Riverside, Calif. 92502.

Simpson Timber Co.

Brochure shows the company's line of reuse concrete form panels. Contact Dean Matthews, Simpson Timber Co., 900 4th Ave., Seattle, Wash. 98164.

Resources from Suppliers and Manufacturers

Symons Corporation

Two brochures are available: "Architectural Form Liners and Concrete Forming Systems" illustrates possible applications. "Pile Restoration and Preservation System" describes the system's capability of restoring the structural integrity of seriously damaged wood, steel or concrete piling.

Contact George A. Rutkowski, Publicity/Promotion Administrator, Symons Corporation, 200 E. Touhy Ave., Des Plaines, Ill. 60018.

Thoro System Products

Will provide its orange binder, which is a catalog of the entire Thoro System line of waterproofing products for masonry and concrete. Additional service available is a two-day miniclinic with "hands-on" experience at Centerville, Ind., Bristol, Pa., and Newark, Calif.

Contact Frank E. Fiske, Manager, Marketing Communications, Thoro System Products, 7800 N.W. 38th St., Miami, Fla. 33166.

Youngstown Design Center

Catalog explains total precast concrete building systems for warehouse-industrial buildings and parking structures.

Contact Youngstown Design Center, 435 Main Street, Youngstown, N.Y. 14174.

UCI 4: Masonry

Acme Brick Co.

Nine continuing education programs are available for presentation: masonry specifications review, ASTM masonry specifications review, architectural options, development of engineered brick masonry, workmanship, differential movement, a critical comparison, matching brick on existing buildings and pre-fabricated brick masonry—Sarabond Mortar. In addition, three publications are offered: "Architectural Options," "Special Shapes" and "Double Wall Brochure."

Contact Fayette Ellis, Manager, Marketing Communications, Acme Brick Co., Box 425, Fort Worth, Tex. 76101.

Brick Institute of America

Provides a series of publications containing technical, design and engineering information on the construction of brick masonry buildings. Information is also

available on energy conservation, including passive solar design and detailed calculations, worksheets and the effects of mass. Other publications cover architectural and structural design, fire resistance, sound control, guide specifications and reprints of appropriate ASTM standards. A catalog lists the institute's literature and aids.

Contact Charles N. Farley, Director of Marketing, Brick Institute of America, 1750 Old Meadow Road, McLean, Va. 22102.

Buckingham-Virginia Slate Corporation

Offers catalog and samples of the company's roofing slate, slate flooring and flaggings and other structural slates.

Contact Al Saunders, Buckingham-Virginia Slate Corporation, 4110 Fitzhugh Ave., Richmond, Va. 23230.

Burns & Russell Co.

Offers a comprehensive color booklet featuring Spectra Glaze, prefaced glazed concrete block walls. Also available are a spec-data sheet that contains test reports for ASTM federal specifications and a 12-minute LaBelle cassette presenting facts on masonry walls.

Contact John McDonald, Marketing Director, Burns & Russell Co., P.O. Box 6063, Baltimore, Md. 21231.

International Masonry Institute

Offers booklets, films and slide shows on masonry design characteristics, energy conservation capabilities of masonry, loadbearing masonry design and fire protection. Some booklets, films and slide shows are specifically for use in architectural schools. The Institute can also provide contact with more than 75 local/regional masonry institutes throughout the U.S. and Canada, some of which have comparative cost information for their areas.

Contact International Masonry Institute, Suite 1001, 823 15th St. N.W., Washington, D.C. 20005.

Stark Ceramics, Inc.

The technical guide for structural facing tile provides details on structural tile sizes, bonding patterns, color reflectivity, fire, heat and acoustic tables, wall constructions and estimated procedures. The firm will also provide an 18-minute slide and tape presentation.

Contact C. J. Deimling, Stark Ceramics, Inc., P.O. Box 8880, Canton, Ohio 44711.

Stucco Stone Products, Inc.

Will supply brochures containing information and color photographs on a complete line of manufactured stone veneers.

Contact Phil Meredith, Marketing Manager, Stucco Stone Products, Inc., P.O. Box 237, Napa, Calif. 94558.

UCI 5: Metals

Alcan Building Products

Two brochures describe and give specifications for Alcan's singlehangs and gliders tilt windows designed for southern and for northern states. Other brochures show the company's insulating aluminum doors, storm doors, awning windows and aluminum siding.

Contact *Alcan Building Products, P.O. Box 1234, Department R., Youngstown, Ohio 44501.*

Armco

Brochures available on Aluminized Steel Type 2 and on the firm's Zincgrip Steels. Contact *Carl Butts, Manager, Coated Products Sales, Armco, Middletown, Ohio 45043.*

Copperweld Tubing Group

Brochure contains information on size ranges and technical specifications for the firm's Copperweld cold formed, electric welded structural tubing. Included are manufacturing processes, testing and inspection procedures, mechanical properties and tolerances.

Contact *Margaret Kennedy, Supervisor/Communications, Copperweld Tubing Group, 2 Robinson Plaza, Route 60, Box 60, Pittsburgh, Pa. 15230.*

Epic Metals Corporation

"Epicore Composite Floor Systems" covers the use of Epicore composite deck in commercial and industrial projects requiring relatively short spans and heavy loading. Also available are brochures on the use of Epicore composite deck with precast beams, poured-in-place concrete beams and the patented Epicore Slab beam; on the use of Epicore composite deck in structures designed with long spans and residential loading; depicting a deck selection chart and technical tables, and on Epic pre-engineered buildings.

Contact *Epic Metals Corporation, 11 Talbot Ave., Rankin, Pa. 15104.*

Follansbee Steel Corporation

Specifications and data manuals, application guides and review of design plans by the firm's engineering department on the firm's products, T.C.S. and Terne metal, are offered.

Contact *Follansbee Steel Corporation, 1133 Terminal Tower, Cleveland, Ohio 44113.*

Fry Reglet Corporation

Offers three brochures covering their complete product line: Plaster and Dry-

wall Moldings, Drapery Pockets and Moldings and Roof Flashings and Reglets. Contact *Robert P. Reed, President, Fry Reglet Corporation, 625 S. Palm Ave., Alhambra, Calif. 91803.*

Guard Nut Inc.

Four-page brochure describes tamper-resistant fasteners and removal tools. Contact *Guard Nut Inc., P.O. Drawer 299, Sonoma, Calif. 95476.*

Harry Lunstead Designs, Inc.

Brochure includes samples and technical information on the company's etched metal laminates. Regional factory representatives will present a color slide show on etched metal manufacturing and installations.

Contact *John Kennell, Harry Lunstead Designs, Inc., 8655 S. 208 St., Kent, Wash. 98031.*

Metal Lath/Steel Framing Association

Illustrated 24-page manual on specifications, applications and descriptions of the versatility of steel framing systems.

Contact *Metal Lath/Steel Framing Association, 221 N. LaSalle St., Suite 2026, Chicago, Ill. 60601.*

Neenah Foundry Co.

320-page construction castings catalog shows manhole covers and adjusters, catch basins and curb inlets, bridge and trench drains, miscellaneous grates, sewerage collection castings.

Contact *J. M. Meyer, Marketing Service Manager, Neenah Foundry Co., P.O. Box 729, 2121 Brooks Ave., Neenah, Wis. 54956.*

PPG Industries, Inc.

12-page illustrated booklet gives performance and appearance characteristics of the firm's complete line of entrance, storefront and curtain wall systems.

Contact *PPG Industries, 10 North, 1 Gateway Center, Pittsburgh, Pa. 15222.*

Steel Deck Institute

Criteria for composite floor construction are available in the *Design Manual for Floor Decks and Roof Decks*. Floor deck material includes design recommendations, illustrations of typical assemblies and a design example to explain the procedure for choosing the right product for a given application.

Contact *Steel Deck Institute, P.O. Box 3812, St. Louis, Mo. 63122.*

United McGill Corporation, United Sheet Metal Division

Monthly series of Engineering Bulletins details the results of tests and studies relevant to performance and design of HVAC duct systems including the topics of exposed ducts, noise controls, dual duct systems and high and low level air distribution.

Contact *Bowman Turner, Chief Engineer,*

United McGill Corporation, United Sheet Metal Division, 200 E. Broadway, Westerville, Ohio 43081.

UCI 6: Wood and Plastics

American Plywood Association

Offers a number of publications, audio-visual aids and services demonstrating the varied uses of plywood. Publications include "Stains and Paints on Plywood," "Plywood Construction for Fire Protection," "All-Weather Wood Foundation" and "Plywood Ideas for Multifamily Housing." Films available for loan or purchase are "Finishing Plywood Siding," "AWWF in Rapid City," "APA Glued Floor System," "Plen-Wood System" and "The Engineered 24-Inch Framing System." Films available on a loan basis are "In Pursuit of Happiness," a 25-minute presentation of the nation's housing needs; "Design vs. Nature's Violence," a 22-minute film showing plywood structures that withstood the 1964 Alaska earthquake; "Plans Approved," a 27-minute film on the importance of building codes, and "Miracle in Wood," a look at the development of plywood.

Contact *Maryann Ezell, Public Relations, American Plywood Association, P.O. Box 11700, Tacoma, Wash. 98411.*

Field representatives will supply design professionals with information on plywood and design assistance.

Contact *Herman Glover, Director, Field Services Division, American Plywood Association, P.O. Box 11700, Tacoma, Wash. 98411.*

California Redwood Association

Offers four guides: a plywood guide, a landscape guide and interior and exterior guides. Each brochure provides information on wood patterns, grades, grains and finishes.

Contact *California Redwood Association, One Lombard St., San Francisco, Calif. 94111.*

E. I. du Pont de Nemours & Co.

A 12-page brochure describes the uses and performance of Lucite L cast acrylic sheet and Lucite SAR Super Abrasion Resistant sheet products in building construction. Included is information on specification write-up, code and specification compliance and tips on care and handling.

Contact *Public Affairs Department, E. I. du Pont de Nemours & Co., WT-702, Room 37574PA, Wilmington, Del. 19898.*

continued on page 142



The natural look of aluminum... works beautifully in Denver.

The Denver National Bank Plaza is a beautiful example of the use of Alcoa® architectural sheet in a major curtain-wall project. An office complex consisting of a 26-story tower and two adjacent buildings, it was designed to meet the Denver Urban Renewal Authority exterior facade specifications.

Alcoa supplied approximately 400,000 lbs of specially controlled 5005 alloy sheet to PPG Industries for fabrication and finishing of the spandrel panels. The pleasing natural aluminum finish is Alumilite 215, Alcoa 1 etched and anodized (AA-M10C22), providing a long lasting, corrosion resistant protective coating.

Bill Manning, PPG Branch Manager, sums up Alcoa's contribution to the project: "The Denver National Bank Plaza is typical of the quality and service we continually receive from Alcoa. From the supplying of high quality aluminum sheet to the furnishing of fine technical information and service, Alcoa plays an important part in our success in this field."

Let Alcoa help you on your next curtain-wall application. For more information, write Aluminum Company of America, 1207 Alcoa Building, Pittsburgh, PA 15219.

The Denver National Bank Plaza,
Denver, Colorado
Fabricator: PPG Industries, Inc.
Architect: Skidmore, Owings and Merrill
Contractor: N. G. Petry Construction Co.
Developer: N. G. Petry Construction Co.
Owner: L. C. Fulenwider, Inc.

We can't wait for tomorrow.

 **ALCOA**

Circle 61 on information card

UCI from page 140

Forms + Surfaces

Brochures describe Sculpturewood, Panelcarve and Tambour/Bonded Hardwood wall panels.

Contact Jan Winter, Director of Communications, *Forms + Surfaces*, Box 5215, Santa Barbara, Calif. 93108.

Koppers Co., Inc.

"Laminated Wood Structures" describes uses, types and applications for laminated wood systems. "Koppers Pressure Treatments Help Wood Serve You Longer" outlines the types of pressure treatments, recommended uses, advantages and limitations to assist in selecting treated wood for a building project.

Contact Koppers Co., Inc., Forest Products Group, 1900 Koppers Building, Pittsburgh, Pa. 15219.

Louisiana-Pacific

Color catalog describes wood building products, including L-P Redex phenolic particleboard construction panels and L-P Waferwood structural panels. In addition, individual specification sheets, installation information and physical samples are available on various lumber, panel and millwork products.

Contact Louisiana-Pacific Corporation, 1300 S.W. Fifth Ave., Portland, Ore. 97201.

Monitor Products

Literature features both the technical and design aspects of the company's plastic laminate line.

Contact George Unteseher, National Sales Manager, Monitor Products, 3000 S. Alaska, Tacoma, Wash. 98409.

Penply

Offers a brochure covering descriptive and technical information for Penply Western Red Cedar Exterior 303 Plywood Siding.

Contact Penply, 439 Marine Drive, Port Angeles, Wash. 98362.

PPG Industries

"Use Solar Daylight and Heat" is a 20-page illustrated brochure based on government and professional studies contending that direct solar daylight and heat transmitted through high-performance glass windows can save electric energy and conserve the nation's fossil fuels. In addition, a new booklet describes tempered safety glass doors and frames. The firm has also developed a computer-based system to recommend glass type, thickness, size and strength to meet architectural specifications. Energy and cost analyses related to use of solar day-

light and heat can be prepared.

Contact Public Relations Department, PPG Industries, Inc., One Gateway Center, Pittsburgh, Pa. 15222.

Ralph Wilson Plastics Co.

The 1980 collection of 108 Wilsonart brand decorative laminates is described in a 12-page booklet. Also available are booklets describing the 1980 design group 1 collection of solid color decorative laminates; Tuf-Surf decorative laminates; eight kitchen and four bath designs for 1980, and the 1980 collection of metallic laminates for commercial or residential applications. An audiovisual presentation introducing the firm's products is available.

Contact Ed Duncan, Market Planning Assistant, Ralph Wilson Plastics Co., 600 General Bruce Drive, Temple, Tex. 76501.

Red Cedar Shingle & Handsplit Shake Bureau

Presents an eight-page brochure, "Red Cedar Shingles & Shakes," depicting the textures and patterns available with shingles and shakes. Several examples are shown.

Contact Red Cedar Shingle & Handsplit Shake Bureau, Suite 275, 515 116th Ave. N.E., Bellevue, Wash. 98004.

Shake and Shingle Panels, Inc.

Offers literature on preassembled, eight-foot red cedar roofing (SR-11) and siding (SNW-8) panels.

Contact O. Steven Martin, General Manager, Shake and Shingle Panels, Inc., 980 S. Fifth St., San Jose, Calif. 95112.

Shakertown Corporation

Offers a full-color 12-page catalog on cedar siding and roofing panels. Also available is literature on Mansards, single family homes and Fancy Cuts decorative shingles.

Contact Ed Stanton, National Sales Manager, Shakertown Corporation, 1200 Kerron Ave., Winlock, Wash. 98596.

Simpson Timber Co.

Eight-page Ruf-Sawn Redwood brochure illustrates the variety of form and function attainable with redwood plywood. Also offered is a Stucco 316 brochure which features applications of the product. Material descriptions are included.

Contact Dean Matthews, Simpson Timber Co., 900 4th Ave., Seattle, Wash. 98164.

TheWoodBook

The 1980 WoodBook provides 400 pages of information on the industry's leading associations and manufacturers. It includes information on wood products, recommendations for subfloor and underlayment, specifications for all wood products, recommendations for construction systems and finishes for wood surfaces.

\$12; \$10 to specifiers. Orders of 20 or more books are \$9 per book.

Contact TheWoodBook, Department A, 3516 Sacramento St., San Francisco, Calif. 94118.

Trus Joist Corporation

Design manual and brochures are available describing the firm's structural roof and floor systems.

Contact Pete Kowalchuk, Trus Joist Corporation, P.O. Box 60, Boise, Idaho 83707.

Western Wood Products Association

Offers the revised second edition of the "Western Wood Use Book," a sourcebook with more than 300 pages of text, illustrations, examples, photographs, design tables, loads and deflections for joists and beams. \$20. Also available is the product use manual which contains lumber sizes, grades and design values, floor and ceiling joist span tables and decking spans.

Contact Shar Escudero, Western Wood Products Association, Yeon Building, Portland, Ore. 97204.

Field representatives will assist design professionals with information on lumber uses and specifications.

Contact C. V. Riolo, Manager, Field Services, Western Wood Products Association, Yeon Building, Portland, Ore. 97204.

Weyerhaeuser Co.

Three catalogs on siding and paneling are offered: "Hardboard Siding" features lap and panel hardboard siding in four surface textures, primed or prefinished; "Prefinished Siding Panel 15" shows uses, specifications and construction details of the aluminum overlaid plywood panel; "Paneling" gives product specifications and includes photographs of Weyerhaeuser's designer wall paneling.

Contact Weyerhaeuser Co., Tacoma, Wash. 98401.

Willamette Industries, Inc.

Offers information on Duraflake FR Class 1 fire rated particleboard corestock. Contact Duraflake Division, Willamette Industries, Inc., P.O. Box 428, Albany, Ore. 97321.

Wood Specialty Products

Catalog features accordian style folding wood doors and room dividers for commercial, institutional and residential use. Detailed drawings on standard all-wood nonparticle board doors and custom capabilities are also featured. A color film strip is available.

Contact Mike Garrett, National Sales Manager, Wood Specialty Products,

continued on page 144

PenPly exterior cedar pays dividends by the hour.

PenPly Western Red Cedar Exterior Plywood 303 Siding gives you the real economy of reduced labor costs—while you retain the quality and appeal of cedar siding.

For example, the house pictured here requires only 120 PenPly panels and takes about 91 manhours to cover. Compare that with the 169 manhours it could take to cover an equal area with a piecework siding. That's time, not to mention money, you can't afford to waste.

Buyers also appreciate cedar for its even grain, warm tones, weather resistance and freedom from maintenance. That's why you can afford to step up to cedar and realize a much greater profit when the home is sold.

In order to show you the design and profit possibilities of cedar, PenPly, the leading producer of quality cedar siding, has published a *free brochure*. It contains floor plans to this house, design details and facts.

For more information, contact your wood products distributor, or see Sweet's General Building and Light Residential Files under Siding/Cladding Section (7.6 Pen).

PenPly
Wood Products from ITT Rayonier Inc.

Circle 63 on information card

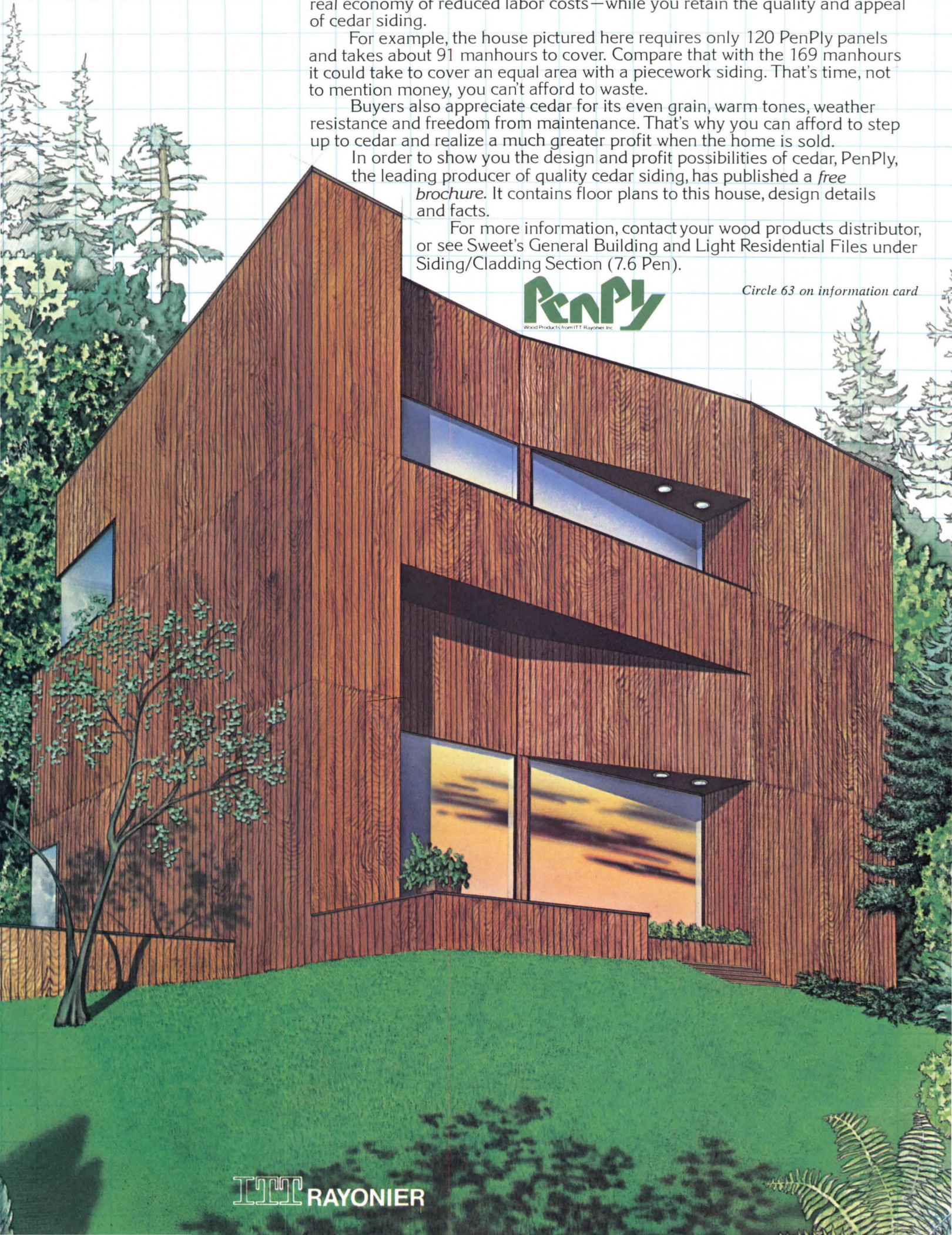

UCI from page 142

24300 W. 60th St., Mountlake Terrace, Wash. 98043.

Youngstown Design Center

Catalog, with price list, describes the Klem Connector, which can be used to join panels of any materials with thicknesses varying from one-sixteenth inch to three-fourths inch.

Contact Youngstown Design Center, 435 Main Street, Youngstown, N.Y. 14174.

UCI 7: Thermal & Moisture Protection

American Air Filter Co., Inc.

Offers brochure describing EnerCon systems for commercial buildings. The system reclaims, recycles and stores energy for heating or cooling.

Contact American Air Filter Co., Inc., 215 Central Ave., Louisville, Ky. 40277.

Architectural Engineering Products Co.

Information available on the Structural Batten System, designed to be installed over open space framing such as light gauge steel purlins.

Contact Thomas H. Blackwood, Vice President, Architectural Engineering Products Co., P.O. Box 81664, San Diego, Calif. 92138.

Armco Building Systems

Three brochures describe Armco energy-efficient roof and wall systems.

Contact Armco Building Systems, Box 800, Department B-4180, Middletown, Ohio 45043.

Celotex Corporation

Literature describes Celo-Glass IV Ply Sheet Membrane System, both smooth and gravel surface. Also available is the 1980 Celotex Roof Insulations Sweets Catalog.

Contact Joanne Cardoso, Communications Specialist, Celotex Corporation, P.O. Box 22602, Tampa, Fla. 33622.

Chevron U.S.A. Inc.

Brochure describes Chevron Industrial Membrane, a petroleum hydrocarbon-urethane elastomer used in roofing, water ponds, waste pond linings, cargo containers, refinery applications, marine applications and as a lining for tanks and vats.

Contact William C. Bradshaw, Special Products Division, Chevron U.S.A. Inc., 575 Market St., San Francisco, Calif. 94105.

Compo Industries, Inc.

"Compo's Settef Thermal Wall Insulation and Finish System" includes a brochure, color charts, technical and installation instructions, test reports, details of applica-

tion drawings, job and building photographs and code approvals.

Contact Donald B. White, Compo Industries, Inc., Chemical Specialties Group, 125 Roberts Road, Waltham, Mass. 02254.

E. I. du Pont de Nemours & Co.

See p. 140 (UCI 6).

Follansbee Steel Corporation

Offers specification and data manuals, application procedures and review of plans by its engineering department, for Terne coated steel and T.C.S. corrosion-resistant maintenance-free metal for roofing and flashing.

Contact Follansbee Steel Corporation, 1133 Terminal Tower, Cleveland, Ohio 44113.

Grefco Inc.

The Permalite roof insulation brochure details physical characteristics and uses of perlite board, urethan board, perlite-urethan composite board and true sand-wich board. A CSI Spec-data sheet is available. Other brochures cover Metal-astic expansion joint cover and the Perma-fastner system of attachment of rigid insulation to metal roof decks. Also available are brochures on Insulating Concrete Roof decks and Perlite Masonry Fill insulation.

Contact Merchandising Manager, Grefco, Inc., Building Products Division, 3450 Wilshire Blvd., Los Angeles, Calif. 90010.

Johns-Manville Sales Corporation

Offers brochure on Fire-Glass III fiberglass shingles for residential roofing applications. Another brochure illustrates the differences in cardboard, wood and fiberglass-based roofing and quotes building code officials, builders and firemen about roofs and fires.

Contact Johns-Manville Service Center, 1601 23rd St., Denver, Colo. 80216

Koppers Co., Inc.

Roofing and waterproofing systems for industrial buildings are pictured and described in a brochure that also contains recommended roofing specifications and procedures.

Contact Koppers Co., Inc., Organic Materials Group, 1900 Koppers Building, Pittsburgh, Pa. 15219.

Owens-Corning Fiberglas Corporation

Brochures cover organic and inorganic built-up roofing products, and Fiberglas and FURI roof insulation and recover roof board, including specifications, and thermal performance data.

Contact O. M. S. Meeks, Owens-Corning Fiberglas Corporation, Fiberglas Tower, Toledo, Ohio 43659.

Perlite Institute Inc.

Brochure details the physical properties

and performance of Perlite loose fill.

Contact Perlite Institute Inc., 45 W. 45th St., New York, N.Y. 10036.

Red Cedar Shingle & Handsplit Shake Bureau

See p. 142 (UCI 6).

Rollamatic Roofs Inc.

Offers a brochure on operable skylight roofs for all types of buildings. Roof panels can be opened to vent moisture or allow natural ventilation during rainy weather, and qualify for the federal and California solar tax credit.

Contact Rollamatic Roofs Inc., 1400 Yosemite Ave., San Francisco, Calif. 94124.

Sanspray Corporation

Brochure covers basic product data on Sanspray's stone on plywood panels.

Contact Debra McClenahan, Sanspray Corporation, 630 Martin Ave., Santa Clara, Calif. 95050.

Shakertown Corporation

See p. 142 (UCI 6).

3M

Offers literature on Scotch-Clad Coating Systems elastomeric products that cure when exposed to moisture, for vehicular and pedestrian decks, roofs, buried membrane and special surfaces.

Contact Ann M. McGuigan, Sales Promotion and Merchandising Coordinator, 3M Co., Adhesives, Coatings and Sealers Division, 3M Center, St. Paul, Minn. 55101.

Thoro System Products

See p. 139 (UCI 3).

VIP Enterprises, Inc.

Information available on Ter-Polymer sealants #5000 Series, Ter-Polymer coatings #7000 and #8000 Series, Fire Retardant Roofing Material #3500, Foam Guard #4000, "Ombrella" Clear #9100 and #9500 and "Ombrella" semi-Opaque #9300.

Contact Peter B. Anderson, VIP Enterprises, Inc., 9690 N.W. 41st. St., Suite 1, Miami, Fla. 33178.

UCI 8: Doors and Windows

Alcan Building Products

See p. 140 (UCI 5).

Andersen Corporation

Offers a tracing detail file, a three-ring binder of scaled details; window detail catalog with specifications and technical data; booklets on commercial applications and permashield installation.

Contact Sales Promotion Department, Andersen Corporation, Bayport, Minn. 55003.

Cal-Wood Door

Offers technical literature on its complete line of wood fire doors.

Contact Jim Brower, Sales Department, Cal-Wood Door, P.O. Box 1656, Santa Rosa, Calif. 95402.

Caradco Corporation

44-page catalog explains the energy-saving features of the firm's primed and aluminum clad windows, including solar control insulating glass, leakproof-vinyl gaskets, secure locking devices and double weatherstripping.

Contact Gary Blum, Caradco Corporation, P.O. Box 920, Rantoul, Ill. 61866.

Cookson Co.

28-page, 1980 catalog lists Rolling Service Doors and associated products. Includes data, drawings, specifications and photographs.

Contact Robert A. Cookson, The Cookson Co., 700 Pennsylvania Ave., San Francisco, Calif. 94107.

CY/RO Industries

Offers information on Exolite double skinned acrylic and polycarbonate sheets.

Contact CY/RO Industries, 697 Route 46, Clifton, N.J. 07105.

Du Pont Co./Laminated Safety Glass Association

The film "Laminated Safety Glass/The Designer's Choice" presents the functions and esthetics of laminated safety glass.

Contact E.I. du Pont de Nemours & Co., Advertising Department, Audiovisual Section, Wilmington, Del. 19898.

E. A. Nord Co.

Offers two catalogs: Entry Door catalog illustrates the manufacturer's carved and decorative door designs and provides complete specifications. Bifold catalog illustrates the firm's five Hemlock bifold designs and provides complete size information.

Contact Carol Trotto, E. A. Nord Co., P.O. Box 1187, Everett, Wash. 98206.

Eggers Hardwood Products Corporation

Catalogs and specifications available on Architectural Solid Core Wood Doors, B-Label Wood Composite Fire Doors, Acoustical Doors and X-Ray Doors.

Contact Eggers Hardwood Products Corporation, 164 N. Lake Street, Neenah, Wis. 54956.

Fir and Hemlock Door Association

12-page manual assists architects in specifying stile and rail, fir and hemlock panel doors. Includes illustrations, specifications, sizes, grades, designs, thermal doors and glass sizes for exterior sash and French doors and side lights.

Contact Shar Escudero, Fir and Hem-

lock Door Association, Yeon Building, Portland, Ore. 97204.

Form + Surfaces

Brochures describe Panelcarve doors, Sculpturewood doors, System 7 doors, Bonded Bronze doors, Bonded Wood doors and Doorpulls.

Contact Jan Winter, Director of Communications, Forms + Surfaces, Box 5215, Santa Barbara, Calif. 93108.

J. G. Wilson Co.

Catalog describes rolling door products and Tee-M storage systems.

Contact Jim Bevan, Executive Vice President, J. G. Wilson Co., P.O. Box 599, Norfolk, Va. 23501.

LCN Closers

"Entrance Accessibility for People Who are Handicapped" discusses the key problems relating to accessibility codes and door control. It also provides information on door control products designed to meet the requirements of the accessibility codes.

Contact Robert G. Hatfield, Marketing Services Manager, LCN Closers, Princeton, Ill. 61356.

Libbey-Owens-Ford Co.

Three-part 35-millimeter sound/slide program, "How to Predict Interior Daylight Illumination," comes with brochure and instruction sheet. \$25.

Contact Libbey-Owens-Ford Co., 811 Madison Ave., Toledo, Ohio 43695.

Louisiana-Pacific Corporation

Color catalogs and specification sheets provide descriptive and technical information on residential wood and aluminum windows and doors, wood clad sliding patio doors and custom aluminum replacement windows for industrial, commercial and institutional applications.

Contact Louisiana-Pacific Corporation, 324 Wooster Ave., N., Barberton, Ohio 44203.

Marvin Windows

Updated architectural file contains construction and elevation tracing details on Marvin wood windows. It also provides complete literature on the firm's product line, including casements, double hungs, single hungs, single-glides, awnings, bows, bays, trapezoid, triangles and more.

Contact Cynthia Taylor, Marvin Windows, Warroad, Minn. 56763.

McGuire Co., Inc.

"Important Facts about Traffic Doors" provides selection factors and features to take into consideration when selecting industrial doors for high traffic areas.

Contact George Atwell, McGuire Co., Inc., One Hudson Ave., Hudson, N.Y. 12534.

Michigan Production Gridding Co.

Catalog describes the 18 models of Soss Invisible Hinges.

Contact Kathy Zotter, Michigan Production Gridding Co., Division of Core Industries, Inc., P.O. Box 628, N. State St., Pioneer, Ohio 43554.

PPG Industries

"Use Solar Daylight and Heat" is a 20-page illustrated brochure that gives technical information compiled from government and professional studies. It aims to show how direct solar daylight and heat transmitted through high-performance glass windows can save electric energy.

Contact PPG Industries, 10 North, One Gateway Center, Pittsburgh, Pa. 15222.

Richards-Wilcox Manufacturing Co.

Catalog describes the company's line of door hardware.

Contact Raul E. Baudouin, Advertising Manager, Richards-Wilcox Manufacturing Co., 174 3rd St., Aurora, Ill. 60507.

Schlage Lock Co.

Literature provides information on hand-crafted custom-made locks, and a wide array of material and technical service information is available on various lock series. Two films are offered on loan.

Contact Tom Hufford, Manager, Marketing Series, P.O. Box 3324, San Francisco, Calif. 94119.

Simpson Timber Co.

Eight-page brochure on Simpson International doors shows carved, old world design doors.

Contact Dean Matthews, Simpson Timber Co., 900 4th Ave., Seattle, Wash. 98164.

Weyerhaeuser Co.

"Architectural Doors" is a 20-page catalog with details and specifications on Weyerhaeuser flush wood doors, including fire rated, sound retardant and X-ray.

Contact Weyerhaeuser Company, Box B, Tacoma, WA 98477.

Wood Specialty Products

See p. 142 (UCI 6).

UCI 9: Finishes

Alcan Building Products

Offers a color brochure on the Alcan Planar floating ceiling system and the Alcan Plenum Mask, which screens wiring and piping. A technical brochure on aluminum canopies is also offered.

Contact Alcan Building Products, P.O. Box 1234, Department R, Youngstown, Ohio 44501.

Armstrong World Industries, Inc.

"Floors—1980 Product Information and Technical Data" is a catalog describing

continued on page 148

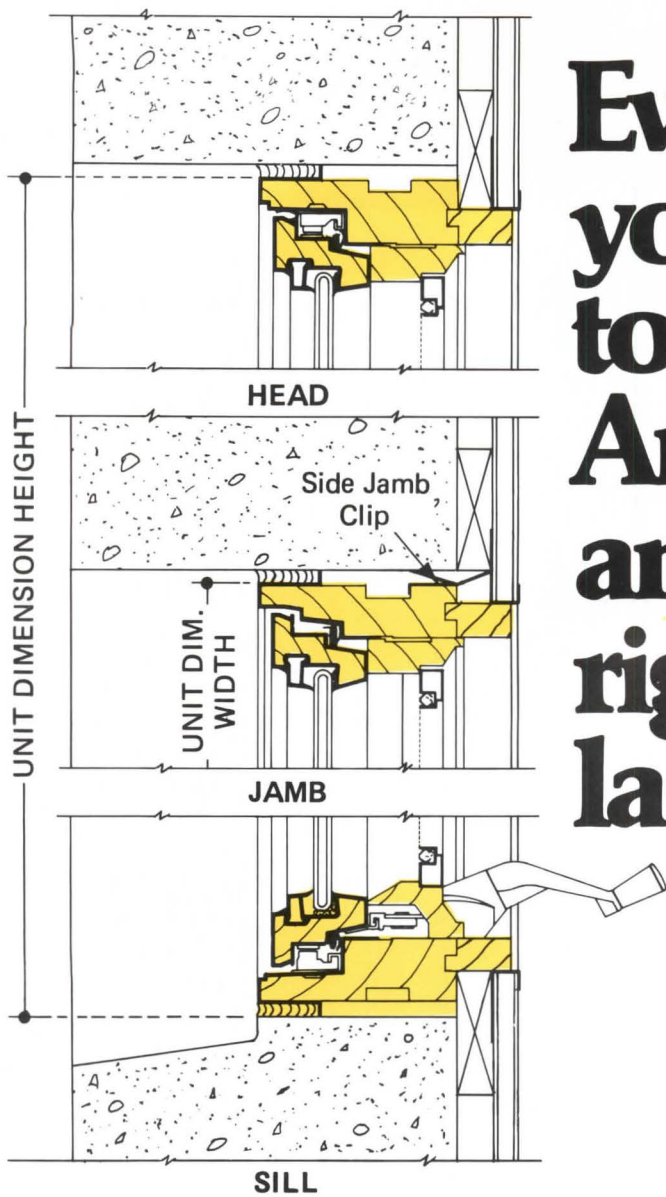

Everything you've wanted to know about Andersen® windows and gliding doors right down to the last beautiful detail.

There's more to specifying quality windows and gliding doors than just their brand name. Even if that name is Andersen®.

To make your job easier, we present the entire Andersen line with complete technical data in every detail. And to scale. In elevations and installations in all types of wall construction.

So now you'll know how the window fits in, before it gets to the job.

There's also an architect's tracing template to take a lot of the time and work out of making your detail drawings.

And an installation detail book. Plus, of course, our Sweet's file on Andersen windows and gliding doors.

And Manu-Specs on all products in conformance with CSI 3-Part Section format.

Isn't it time you had all the facts,

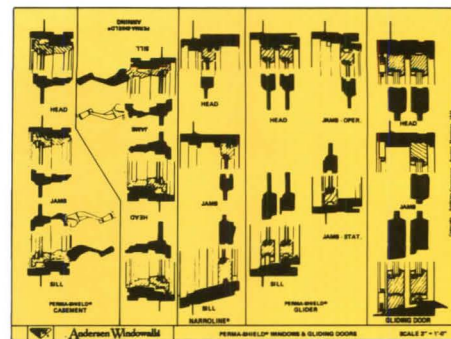
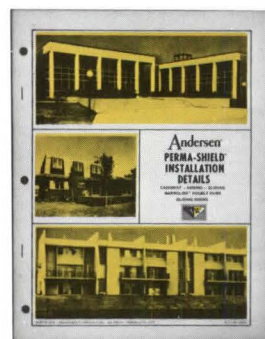
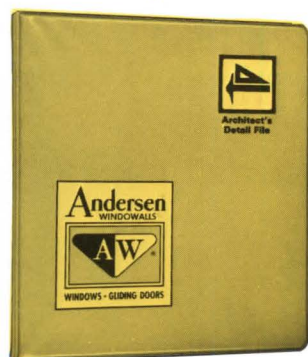
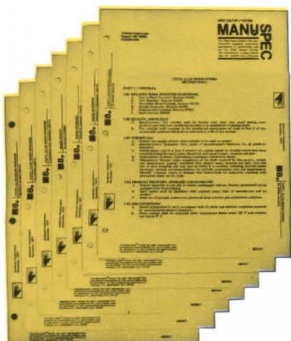

Call Us For All The Facts.

ALABAMA
BIRMINGHAM — Birmingham Sash & Door Co. — (205 254-3276)

ARIZONA
PHOENIX — Santa Fe Lumber & Millwork — (602 257-9042)

ARKANSAS
NO. LITTLE ROCK — Fischer Lime & Cement Co. — (501 376-2911)

CALIFORNIA
FAIRFIELD — Sequoia Supply — (707 864-1711)
OAKLAND — Western Door and Sash — (415 535-2000)
ORANGE — Sequoia Supply — (714 974-2330)

COLORADO
DENVER — Boise-Cascade — (303 629-1629)
DENVER — C-E Morgan Sash & Door Co. — (303 373-0210)

CONNECTICUT
NORTH HAVEN — Brockway-Smith Company — (203 239-1603)
SHELTON — Cleary Millwork Co. — (203 735-1819)

DELAWARE
BEAR — C-E Morgan Millwork Company — (302 332-1227)

FLORIDA
FORT MYERS — Huttig Sash & Door Company — (813 332-2424)
JACKSONVILLE — Huttig Sash & Door Co. (904 786-1622)
LARGO — C-E Morgan Building Products — (813 393-4681)
ORLANDO — Huttig Sash & Door Company — (305 295-9020)
RIVIERA BEACH — Weiler-Wilhelm Window & Door Co. (305 845-1555)

GEORGIA
ATLANTA — C-E Morgan Bldg. Products — (404 691-5117)
NORCROSS — Winter of Atlanta — (404 448-0440)

IDAHO
BOISE — Chandler Corporation — (208 375-5050)

ILLINOIS
DECATUR — Morgan Sash & Door Co. — (217 877-4621)
PEORIA — Wahlfeld Mfg. Co. — (309 673-4421)
ROCK ISLAND — Rock Island Millwork Company — (309 788-0421)
SKOKIE — EHLCO, — (312 761-6600)
WEST CHICAGO — Wahlfeld's — (312 293-1000)

INDIANA
GOSHEN — Goshen Sash & Door Co., Inc. — (219 533-1146)
INDIANAPOLIS — Midland Sash & Door Inc. — (317 637-3381)
TERRE HAUTE — Associated Door & Plywood Co. — (812 232-1371)

IOWA
CEDAR RAPIDS — Rock Island Millwork Company, — (319 365-6904)
DES MOINES — Rock Island Millwork Company — (515 265-6071)
DUBUQUE — Rock Island Millwork Company — (319 588-0551)
MASON CITY — Mason City Millwork Co., Inc. — (515 423-2822)
SIoux CITY — Jordan Millwork Company — (712 258-7554)
WATERLOO — Rock Island Millwork Co. — (319 233-3331)

KANSAS
LENEXA — C-E Morgan Distribution — (913 888-5900)
WICHITA — Rock Island Millwork Co. — (316 264-8375)
WICHITA — Rounds & Porter Co. — (316 262-1465)

KENTUCKY
LEXINGTON — Combs Company — (606 254-3321)
LOUISVILLE — Allied Sash & Door, Inc. — (502 361-8481)
LOUISVILLE — Huttig Sash & Door Co. — (502 491-4560)

LOUISIANA
ALEXANDRIA — Davidson Louisiana, Inc. — (318 442-1355)
BATON ROUGE — Davidson Louisiana, Inc. — (504 387-6746)
HOUMA — Davidson Louisiana, Inc. — (504 879-2313)
KENNER — Davidson Louisiana, Inc. — (504 721-4558)
LAFAYETTE — Davidson Louisiana, Inc. — (318 234-6373)
LAKE CHARLES — Davidson Louisiana, Inc. — (318 439-8393)

MONROE — Davidson Louisiana, Inc. — (318 323-2273)

MAINE
PORTLAND — Brockway-Smith Company — (207 774-6201)

MARYLAND
BALTIMORE — Robbins Door & Sash Co. — (301 796-7766)
BARCLAY — Delmarva Sash & Door Co. — (301 438-3102)

MASSACHUSETTS
ANDOVER — Brockway-Smith Company — (617 475-7100)
EAST LONGMEADOW — Brockway-Smith Company, — (413 525-3377)
SPRINGFIELD — Martin Lumber Company — (413 788-9634)

MICHIGAN
BIRCH RUN — Morgan Sash and Door Co. — (517 624-9383)
GRAND RAPIDS — Grand Rapids Sash & Door Co. — (616 784-1500)
HOLT — Grand Rapids Sash & Door Co. — (517 694-2108)
SCHOOLCRAFT — Grand Rapids Sash & Door Co. — (616 679-5205)
TRAVERSE CITY — Grand Rapids Sash & Door Co., — (616 947-5420)
WIXOM — Kimball & Russell, Inc. — (313 624-7000)

MINNESOTA
DULUTH — The Radford Company — (218 624-3654)
MINNEAPOLIS — Independent Millwork Inc. — (612 425-6600)
ST. PAUL — Pacific Mutual Door Company — (612 631-2211)

MISSOURI
CAPE GIRARDEAU — Associated Building Centers, Inc., — (314 335-8231)
HAZELWOOD — Chromalloy Building Products Div., — (314 731-1401)
KANSAS CITY — Pacific Mutual Door Company — (816 531-0161)
MARYLAND HEIGHTS — St. Louis Millwork Company — (314 872-8724)
ST. JOSEPH — Lumbermen's Supply Company — (816 232-7744)
SPRINGFIELD — Toombs & Company — (417 862-9377)

MONTANA
BILLINGS — Boise-Cascade — (406 652-3250)
GREAT FALLS — Lumber Yard Supply Co. — (406 453-0356)
MILES CITY — Richland Lumber Co., — (406 232-1345)
MISSOULA — Exchange Lumber Co., Montana Division, — (406 549-5121)

NEBRASKA
OMAHA — Disbrow & Co. — (402 341-0774)
OMAHA — Jordan Millwork Co. — (402 334-7660)
SCOTT'S BLUFF — Huttig Sash & Door Co. — (308 436-2151)

NEW JERSEY
MIDLAND PARK — Black Millwork Co., Inc. — (201 445-5700)
RIDGEFIELD — Whittier-Ruhle Millwork Co. — (201 943-6600)
WOODBURY HEIGHTS — Middle Atlantic Millwork Co., — (609 848-8000)

NEW MEXICO
SANTA FE — Santa Fe Lumber & Millwork, Inc. — (505 471-9022)

NEW YORK
ALBANY — Dorsey Millwork Inc. — (518 489-2542)
ALBANY — Iroquois Millwork Corporation — (518 436-9631)
BUFFALO — Iroquois Door Company — (716 856-8144)
DEER PARK — Sturtevant Millwork Corporation — (516 667-6700)
JOHNSON CITY — Robbins Door & Sash Co. — (607 797-1288)
OZONE PARK — Hussey-Williams Co., Inc. — (212 845-3500)
SYRACUSE — Iroquois Door Co. — (315 455-2491)
VICTOR — Iron City Sash & Door Company, — (716 924-3201)

NORTH CAROLINA
CHARLOTTE — Huttig Sash & Door Company — (704 332-1503)
KERNERSVILLE — Huttig Sash & Door Company — (919 996-5221)
ROCKY MOUNT — Huttig Sash & Door Company — (919 446-2446)

NORTH DAKOTA
BISMARCK — The Radford Company, — (701 223-5890)
FARGO — The Radford Company — (701 282-7200)

OHIO
CANTON — Iron City Sash & Door Company — (216 478-1461)
CINCINNATI — Acme Sash & Door Company — (513 242-4400)
CLEVELAND — The Weiler-Wilhelm Lumber Co., — (216 243-5000)
COLUMBUS — Huttig Sash & Door Company — (614 486-4367)
DAYTON — Dayton Sash & Door Company — (513 224-0626)
NORTH LIMA — Iron City Sash & Door Company — 216 549-9801
TOLEDO — Allen A. Smith Co. — (419 537-1373)

OKLAHOMA
OKLAHOMA CITY — Lumbermen's Supply Co. — (405 232-9163)
TULSA — Mid-West Mill & Supply Co. — (918 932-4631)
TULSA — General Sash & Door Co. — (918 622-3131)

OREGON
WILSONVILLE — Sequoia Supply — (503 682-2822)

PENNSYLVANIA
ALLENTOWN — Reeb Millwork Corp. — (215 434-4406)
ALLENTOWN — Robbins Door & Sash Co., Inc. — (215 434-4827)
CARLISLE — Middle Atlantic Millwork Co. — (717 243-5656)
FRACKVILLE — Robbins Door & Sash Co., Inc. — (717 874-1220)
HARRISBURG — Robbins Door & Sash Co., Inc. — (717 238-8101)
MECHANICSBURG — Morgan Millwork Co. — (717 697-0346)
MONTOURSVILLE — Robbins Door & Sash Co. — (717 368-2656)
NORTH HUNTINGDON — Shuster's Building Components, — (412 863-4018)
SANDY LAKE — Iron City Sash & Door Co. — (412 376-7415)
SCRANTON — Robbins Door & Sash Co., Inc. — (717 344-6156)
WILKES-BARRE — Robbins Door & Sash Co. — (717 824-8781)
WINDBER — Iron City Sash & Door Co., — (814 467-4571)

SOUTH CAROLINA
COLUMBIA — C-E Morgan Bldg. Products — (803 254-7084)

SOUTH DAKOTA
SIoux FALLS — Jordan Millwork Company — (605 336-1910)
WATERTOWN — Jordan Millwork Company — (605 886-5801)

TENNESSEE
KINGSPOrt — Holston Builders Supply — (615 247-8131)
MEMPHIS — Memphis Sash & Door Co. — (901 363-6040)
NASHVILLE — Wholesale Building Products — (615 259-4222)

TEXAS
AUSTIN — Davidson Texas, Inc. — (512 444-6701)
DALLAS — Lone Star Wholesale — (214 247-6161)
HOUSTON — Lone Star Wholesale — (713 680-3217)
LUBBOCK — Dea Window & Door Co. — (806 763-7078)
LUBBOCK — Lubbock Sash & Door Co. — (806 763-7695)

UTAH
SALT LAKE CITY — Diehl Lumber Products, Inc. — (801 972-8300)

VIRGINIA
ALEXANDRIA — Morgan Millwork Company — (703 370-5744)
FREDERICKSBURG — Huttig Sash & Door Co. — (703 371-1710)
PORTSMOUTH — Morgan Millwork Company — (804 393-4036)
ROANOKE — Huttig Sash & Door Co. — (703 344-6201)

WASHINGTON
SPOKANE — Exchange Lumber & Mfg. Co. — (509 487-1621)
TACOMA — Savage Wholesale Building Materials, — (206 383-1727)

WEST VIRGINIA
NITRO — Appalachian Sash & Door Co., — (304 755-8251)

WISCONSIN
LACROSSE — The Radford Company — (608 784-2280)
MILWAUKEE — Western Moulding Co., Inc. — (414 258-4686)
OSHKOSH — The Radford Company — (414 231-4880)
WINDSOR — The Radford Company — (608 224-3962)

Right down to the last beautiful detail? Call us or your nearby Andersen distributor. Andersen Corporation, Bayport, MN 55003.

The beautiful way to save fuel®
Andersen Windowalls® 

Circle 64 on information card



UCI from page 145

Armstrong resilient floors, with technical data.

Contact *Armstrong World Industries, Inc., Consumer Services, Box 3001, Lancaster, Pa. 17604.*

Azrock Floor Products

Catalog contains information on sizes, gauges, uses, installation, light reflectance values, colors and brief specifications on Azrock vinyl composition floor tile, asphalt floor tile, feature strips and cove base. Tile samples are available. Also offered are a specification guide, manual of installation and architect's file folder.

Contact *Walter R. Bell, Advertising & Sales Promotion Manager, Azrock Floor Products, P.O. Box 34030, San Antonio, Tex. 78233.*

Badische Corporation

Offers a Contract Carpet Selection and Specifications Guide, Performance Certification brochure and a brochure describing Superblend CR-4. The Create Service System offers consultation on specifications, carpet suitability, samples, seminars and the availability of a library of reference publications on Contract Carpet construction, installation, care and cleaning.

Contact *Badische Corporation, 111 W. 40th St., New York, N.Y. 10018.*

Capaul Ceilings

Softscape brochure describes the acoustic performance of Capaul Nubby and Nubby Open Plan Ceiling Panels.

Contact *Capaul Ceilings, 210 W. 22nd St., Suite 129, Oak Brook, Ill. 60521.*

Celotex Corporation

Literature describes the new Colortone Mineral Fiber Acoustical Ceiling Panels.

Contact *Joanne Cardoso, Communications Specialist, Celotex Corporation, P.O. Box 22602, Tampa, Fla. 33622.*

Connor Forest Industries

Catalog presents specifications for the firm's Maple flooring. "Connor Courts for Racquetball—Handball—Squash" gives specifications for installation of Maple flooring and end and side walls. Another brochure describes the various ways and systems to lay a maple floor for roller rinks.

Contact *L. C. Britten, General Sales Manager, Connor Forest Industries, P.O. Box 847, Wausau, Wis. 54401.*

Conwed Corporation

50-page brochure describes the company's range of architectural ceiling treatments: mineral acoustical ceiling panels and tiles, suspension, integrated ceiling systems and the new Attend B acoustical

wall panel system. Also available are smaller brochures on individual ceiling treatments.

Contact *Sheila A. Katusky, Advertising Department, Conwed Corporation, P.O. Box 43237, St. Paul, Minn. 55164.*

Custom Building Products

Brochure describes the company's mortars, grouts and adhesives for installation of ceramic tile on all types of surfaces. Product line includes Colored Tile Grout, Latex Cement Mortars, Thin-Set Mortars, Veneer Mortar Mastic and Ceramic Tile Mastic.

Contact *Sam Pearce, Custom Building Products, 6511 Salt Lake Ave., Bell, Calif., 90201.*

Diller Corporation

Brochures cover Homapal Metallic Laminates, Dillerwood Wood Veneer Laminates, Dillercloth Fabric Laminates and Homapal's Renaissance collection of real embossed laminates. Also available is a flyer on Resopal Glossy Laminates.

Contact *M. A. Cohen, Marketing Director, Diller Corporation, 6210 Madison Court, Morton Grove, Ill. 60053.*

E. I. du Pont de Nemours & Co.

Brochure provides information on architectural fabric structures coated with Teflon fluorocarbon resin.

Contact *E. A. Browning, Marketing Communications Department, WT-702, Du Pont Co., Wilmington, Del. 19898.*

Flexi-Wall Systems

Information available on nontoxic interior wall finish.

Contact *Hank Levy, Flexi-Wall Systems, P.O. Box 88, Liberty, S.C. 29657.*

Forms + Surfaces

Brochures describe Sculpturewood wall panels, Panelcarve wall panels and Tambour/Bonded Hardwood wall panels, Ceramic Tile, Ceiling Systems, Acoustical Systems, Embossed Metal and Grilles.

Contact *Jan Winter, Director of Communications, Forms + Surfaces, Box 5215, Santa Barbara, Calif. 93108.*

Gail Ceramics

Catalog illustrates the company's various colors, shapes and sizes of ceramic tiles for floors, walls, interiors and exteriors. Also included are short-form specifications and drawings of trim shapes, plus a complete listing of all Gail distributors in the U.S. and Canada.

Contact *Don Orsi, Sales Manager, Gail Ceramics, 1481 N. Main St., Orange, Calif. 92667.*

GF Business Equipment, Inc.

Chart shows the different colors and fabrics available through GF. Also available is a Fabrics and Finishes Swatch Kit, \$15, and a Fabric and Finishes kit containing Open Plan System materials, \$3.

Contact *Cindy Booty, Advertising Coordinator, GF Business Equipment, Inc., 229 E. Dennick Ave., Youngstown, Ohio 44501.*

Integrated Ceilings, Inc.

Film entitled "Ceilings" describes how to develop interesting and effective interior spaces with ceiling surfaces and features the firm's products.

Contact *Integrated Ceilings, Inc., 2231 Colby Ave., Los Angeles, Calif. 90064.*

Interface Flooring Systems

Brochures describe the company's product line. Also available is "Interface: The First Practical Hospital Carpet System" that discusses the special floor covering problems posed to the health-care facility.

Contact *Interface Flooring Systems, Marketing Group, P.O. Box 1503, LaGrange, Ga. 30241.*

Kentucky Wood Floors Inc.

Brochure presents the complete product line of hardwood flooring, from Custom Classics and End Grain Floors to basic Plank and Parquet.

Contact *Kentucky Wood Floors, Inc., 7761 National Turnpike, Louisville, Ky. 40214.*

Latco Products

Brochure discusses the "Wicker" Series of ceramic tile for wall or floor surfaces.

Contact *Buddy Campbell, President, Latco Products, 3371 Glendale Boulevard, Los Angeles, Calif. 90039.*

Levolor Lorentzen, Inc.

Brochure describes linear ceiling systems, profiling their applications in commercial, industrial and residential markets. Also offered are color chips of Daempa and Ecol-O-Vane ceiling systems.

Contact *Levolor Lorentzen, Inc., 720 Monroe St., Hoboken, N.J. 07030.*

Nora Flooring

Information available on Norament tiles, Nora Slate, Nora Ribbed, Nora Smooth, Nora Plan and Nora 600 pastilles.

Contact *Nora Flooring, Division of Robus Products Corporation, 4201 Wilson Ave., Madison, Ind. 47250.*

Olympic Stain

Presents "Before You Begin," a how-to brochure on staining and painting. Illustrated step-by-step instructions simplify finishing for the homeowner all the way from selection of materials through clean-up. The 16-page brochure covers Olympic solid color and semitransparent stains, acrylic latex Olympic stain and Olympic overcoat.

Contact *Paul Kosche, Sales/Promotion*

Manager, Olympic Stain, P.O. Box 1497, Bellevue, Wash. 98009.

Perlite Institute Inc.

Expanded perlite used as a plaster aggregate with Portland Cement or gypsum is documented in a 12-page catalog.

Contact Perlite Institute Inc., 45 W. 45th St., New York, N.Y. 10036.

R. C. Musson Rubber Co.

Catalog on stair coverings presents available colors, cross-section drawings and specifications.

Contact R. C. Musson Rubber Co., 1320 E. Archwood Ave., Akron, Ohio 44306.

Roper Eastern

Information on acoustical ceiling suspension systems and demountable wall framing systems offered.

Contact Roper Eastern, 9325 Snowden River Parkway, Columbia, Md. 21046.

Samuel Cabot Inc.

Offers color cards, displays, technical data sheets, actual wood stain slats and liquid samples of all stain lines. A catalog illustrates and describes the complete stain line.

Contact Samuel Cabot Inc., One Union St., Boston, Mass. 02108.

Simpson Timber Co.

Simpson redwood paneling is displayed in a four-page pamphlet. The various redwood patterns used in interiors are presented and described.

Contact Dean Matthews, Simpson Timber Co., 900 4th Ave., Seattle, Wash. 98164.

Thoro System Products

See p. 139 (UCI 3).

United States Ceramic Tile Co.

Product sheet details Romany Vintage ceramic tile, a four-page brochure features Romany Pavers tile and the 1980 catalog covers almost every type of ceramic tile offered by the firm.

Contact W. K. Day, Advertising Manager, United States Ceramic Tile Co., Subsidiary of Spartek Inc., 1375 Raff Road S.W., Canton, Ohio 44711.

Wellco Carpet Corporation

Information manual is an overview of important tests and requirements by HUD and the National Fire Protection Association. It also lists specifications, testing information, flexibilities and wear classifications on the firm's product line. Another manual recommends installation instructions. The Contract Architectural Folder Kit, \$80, consists of 28 product styles.

Contact Michael J. Casey, National Contract Manager, Wellco Carpet Corporation, P.O. Box 281, Calhoun, Ga. 30701.

Westinghouse Electric Corporation

"Imaginatively!" displays the 101 designs of the decorative laminate line of the Micarta division. The booklet contains illustrations of many practical product applications, as well as technical information on different types of Micarta decorative laminates and their uses.

Contact John Burk, Westinghouse Electric Corporation, Westinghouse Building, Gateway Center, Pittsburgh, Pa. 15222.

UCI 10: Specialties

American-Standard

Will provide blister-packaged, factory color matched samples of its plumbing fixture colors. Nine colors per card. \$1.50. Contact American-Standard, P.O. Box 230, New Brunswick, N.J. 08903.

Best Manufacturing Co.

Catalog illustrates complete sign systems and custom signs and plaques. Also available are the memorial brochure, which shows a wide selection of engraved and Graphic Blast plaques in plastic, brass, bronze, glass, wood and brick, and "How to Develop a Sign System."

Contact Larry Campbell, Best Manufacturing Co., 3212 Troost, Kansas City, Mo. 64109.

Bobrick Washroom Equipment, Inc.

Offers a series of individual Washroom Equipment Planning Guides to assist in the selection and specification of stainless steel washroom accessories and laminated plastic toilet compartments for hotels, hospitals, schools, office buildings and industrial buildings. Also offered is a new Planning Guide for Designing Washroom Facilities for the Physically Handicapped and a Wheelchair Maneuverability Drawing Template.

Contact Bobrick Architectural Service, Lincoln Building, 60 E. 42nd St., New York, N.Y. 10165.

California Cooperage

Offers brochures on the firm's line of wooden hot tubs, redwood decks, sight screens, redwood planters, fiberglass spas and saunas. Also available is the "Architectural Guidebook to Hot Tub Environments."

Contact California Cooperage, 880 Industrial Way, P.O. Box E, San Luis Obispo, Calif. 93406.

Conwed Corporation

See p. 148 (UCI 9).

Forms + Surfaces

Brochures describe cabinet pull designs and wood grilles.

Contact Jan Winter, Director of Communications, Forms + Surfaces, Box 5215, Santa Barbara, Calif. 93108.

Georgia-Pacific Corporation

Offers information on Shaft Liner gypsum wallboard enclosure suitable for elevator duct, stairwell and mechanical shafts.

Contact Ted Godfrey, Gypsum Division, Georgia-Pacific Corporation, 900 S.W. 5th Ave., Portland, Ore. 97204.

GF Business Equipment Inc.

"SPACE—a survey of criteria relating to the application of open plan" deals with office evolution, the state of the office today, SPACE planning and a prospective user's guide. "SPACE" illustrates GF open office products. "The Electra Connection" explains the electrical capabilities of the power raceway in the GF open plan system panel.

Contact Cindy Booty, Advertising Coordinator, GF Business Equipment, Inc., 229 E. Dennick Ave., Youngstown, Ohio 44501.

Haws Drinking Faucet Co.

"Access Fountains" features barrier-free drinking fountains for easy access by wheelchair users. Included are wall-mounted units in both single and double design, freestanding models for outdoor use and models with built-in or optional coolers. Coolers specification charts are included.

Contact Haws Drinking Faucet Co., P.O. Box 1999, Berkeley, Calif. 94701.

INTEST Laboratories, Inc.

Brochure explains the firm's consulting, testing and monitoring services. It describes the company's acoustical analysis laboratory that evaluates open plan offices, ceiling acoustics and electronic background masking. Also outlined is INTEST's expertise in fire and flammability testing.

Contact Donald J. Valsvik, President, INTEST Laboratories, Inc., 2820 Anthony Lane S., Minneapolis, Minn. 55418.

Jacuzzi Whirlpool Bath

The 1980 Jacuzzi Whirlpool Bath and Spas booklets contain installations, diagrams, descriptions and specifications of the company's complete line.

Contact Denise Bina-Everhart, Jacuzzi Whirlpool Bath, P.O. Drawer J, Walnut Creek, Calif. 94596.

Kohler Co.

212-page catalog of plumbing and leisure products for residential, commercial and institutional installations. Includes descriptions and specifications for spas, environmental enclosures, whirlpool baths, bathtubs, lavatories, toilets, drinking fountains, sinks and faucets. Booklets on each product are available.

Contact Lewis Hildebrand, Supervisor,

Production and Procurement, Advertising and Promotional Services, Kohler Co., Kohler, Wis. 53044.

Kroin: Architectural Complements

Presents press materials on products that have been in production for many years but have only recently become available in the U.S. Pictured in the brochures are VOLA sanitary fittings, ALAPE vitreous enamel sinks and ERLAU park furniture. Contact Lawrence Kroin, Director, Kroin: Architectural Complements, P.O. Box 168, Lincoln, Mass. 01773.

Panel Concepts, Inc.

Offers literature and data covering open plan furniture systems and work stations. Data are also available on the company's panel line.

Contact Richard Dittrich, Special Programs Manager, Panel Concepts, Inc., 3001 S. Yale St., Santa Ana, Calif. 92704.

Peninsula Plywood

Offers catalog on western red cedar plywood sidings.

Contact Karl Alteneder, Sales Manager, Peninsula Plywood, 439 Marine Drive, Port Angeles, Wash. 98362.

Rally Racks

Will provide literature on architecturally designed secure bicycle, moped and motorcycle parking stands.

Contact Rally Racks, P.O. Drawer 299, Sonoma, Calif. 95476.

RAR Enterprises

Brochure features the firm's line of wash-room equipment. Also offered are specification sheets on each product.

Contact RAR Enterprises, P.O. Box 2645, Houston, Tex. 77001.

Readybuilt Products Co.

Information available on the company's products: wood mantel pieces for built-in masonry fireplaces and factory built metal fireplaces; decorative fireplaces for town houses and apartments and facing systems for factory built metal fireplaces.

Contact Readybuilt Products Co., P.O. Box 4306, Baltimore, Md. 21223.

Republic Steel

"Why Buy Republic Lockers" discusses the utilization and benefits of Republic Steel Lockers. It includes a description of the full line of types, sizes and accessories.

Contact J. M. Ashcom, Manager, Marketing Communications, Republic Steel, Industrial Products Division, 1038 Belden Ave. N.E., Canton, Ohio 44705.

Richards-Wilcox Manufacturing Co.

Two catalogs are available: One describes the 2200 Series Steelwall operable wall systems; the other the firm's line of

portable walls.

Contact Paul E. Baudouin, Advertising Manager, Richards-Wilcox Manufacturing Co., 174 3rd St., Aurora, Ill. 60507.

Spacesaver Corporation

A comprehensive planning guide to assist architects and builders in designing high density filing/storage systems is available.

Contact Space Planning Services, Spacesaver Corporation, 1450 Janesville Ave., Ft. Atkinson, Wis. 53538.

Steelcase Inc.

Three-day Workstation Planning seminar is designed to acquaint office planners with the latest planning concepts and furniture available. \$100. Office Survey and Space Planning seminar is a structure analytical approach to the planning project regardless of project size. \$175.

Contact C. E. Halterman, Sales Promotion Supervisor, Steelcase Inc., Grand Rapids, Mich. 49501.

Unistrut Interior Building Systems

Complete specifications on four movable interior wall systems are included in a 20-page catalog. Also included are specifications on a variety of matching doors, hardware and accessories.

Contact Rich Drakulich, Unistrut Interior Building Systems, 1821 Bedford Ave., North Kansas City, Mo. 64116.

Vicking Leisure Products Co.

Offers literature on the company's complete line of health and leisure products, including prebuilt and custom sauna rooms, whirlpool baths, hot tubs, spas, steam units and wine systems.

Contact Kevin Jones, Viking Leisure Products Co., P.O. Box 6298, San Jose, Calif. 95150.

Youngstown Design Center

Interior and exterior sign systems are described in a catalog.

Contact Youngstown Design Center, 435 Main St., Youngstown, N.Y. 14174.

UCI 11: Equipment

Atkinson Dynamics

Offers information on heavy-duty industrial intercoms.

Contact Asa Bullock, Sales Manager, Atkinson Dynamics, 10 W. Orange Ave., South San Francisco, Calif. 94080.

Kroin: Architectural Complements

See above (UCI 10).

McGuire Co., Inc.

Offers a film on the Autodok System in operation at a warehouse loading dock. Appointment necessary.

Contact George Atwell, McGuire Co., Inc., One Hudson Ave., Hudson, N.Y. 12534.

Pellerin Milnor Corporation

Architects' Laundry Planning File includes literature on the firm's commercial washing machinery. A 10-minute file is offered on the Hands-Off Washing System that includes large tilting washer-extractors that load and unload themselves. Costs and equipment analyses and layout drawings are offered by the Laundry Planning Department. "What's New in Large Laundry Systems" describes automated washer-extractors, materials handling systems and a water and heat recovery system.

Contact A. W. Walsdorf, Senior Vice President, Pellerin Milnor Corporation, P.O. Box 400, Kenner, La. 70063.

R. C. Musson Rubber Co.

The firm's line of dock bumpers, impact bumpers, wheel chocks and corner guards is presented in a four-page catalog.

Contact R. C. Musson Rubber Co., 1320 E. Archwood Ave., Akron, Ohio 44306.

UCI 12: Furnishings

Atelier International, Ltd.

Specification sheets available on the firm's latest lighting and furniture designs: Leonardo Chair collection, Cab Arm Chair, Arco Lounge Chair, Archizoom Seating, La Loggia Tables, Frisbi Pendant Lamp, Papillona Floor Lamp and Bollo Wall Lamp.

Contact Atelier International, Ltd., 595 Madison Ave., New York, N.Y. 10022.

Best Manufacturing Co.

Offers information on Graphic Blast process, which can engrave almost any black and white artwork into virtually any material.

Contact Best Manufacturing Co., 3214 Troost, Kansas City, Mo. 64109.

Brayton International

Information available on the Brayton line of furniture including Refugio, an easy chair with add-on elements to form seating groups.

Contact Brayton International, P.O. Box 2558, 113 Mottsinger, High Point, N.C. 27261.

Charrette

1980 catalog describes furniture available: Wilde and Spieth office chairs, Krueger Vertebra Seating, Royalmetal chairs and stools, among others.

Contact Charrette, 21 Olympia Ave., Woburn, Mass. 01801.

Conwed Corporation

Brochures describe its varied lines of freestanding acoustical screens, wood

desks, open office componentry and furniture systems. Also available are two brochures outlining the role of acoustics in the open plan office.

Contact Sheila A. Katusky, Advertising Department, Conwed Corporation, P.O. Box 43237, St. Paul, Minn. 55164.

E. I. du Pont de Nemours & Co.

Brochure ranks the 25 most frequently specified carpets in 1979, based on a survey of building projects valued at \$1 million or more in which contract carpet was specified. Also offered are specification guides on commercial carpet of "Antron" III nylon.

Contact Judith Mortenson, Public Affairs Department, E.I. du Pont de Nemours & Co., 350 Fifth Avenue, New York, N.Y. 10001.

Falcon

Offers information on new products: Hannah/Grasso Wire Chair collection, table base collection designed by Fredrick Kuhn, stubby stacking chair designed by Robert DeFuccio and the Park Bench Booth designed by Matthew Beals.

Contact Falcon, 9387 Dielman Industrial Drive, St. Louis, Mo. 63132.

Forms + Surfaces

Brochures illustrate benches, planters, smoking urns and trash receptacles, which are all modular.

Contact Jan Winter, Director of Communications, Forms + Surfaces, Box 5215, Santa Barbara, Calif. 93108.

GF Business Equipment, Inc.

Product brochures and catalogs describe GF's chair lines, filing systems, desk lines, bookcases and Open Plan System products.

Contact Cindy Booty, Advertising Coordinator, GF Business Equipment, Inc. 229 E. Dennick Ave., Youngstown, Ohio 44501.

Heidapal Group-West, Inc.

Offers a catalog and brochure displaying the European design and craftsmanship of the firms' kitchen and bath cabinetry. Catalog, \$5.

Contact Lynn Schroeder, Heidapal Group-West, Inc., 749 Swift St., #1, Santa Cruz, Calif. 95060.

Helikon Furniture Co., Inc.

Color brochure describes the Options System for open office planning. It comes with 44-page illustrated net price list.

Contact Helikon Furniture Co., Inc., Tatville, Conn. 06380.

Kirsch Co.

Offers a manual to assist in selecting custom tracks and heading systems especially appropriate for commercial installations.

Contact Kirsch Co., Department AN, Sturgis, Mich. 49091.

Koppers Co., Inc.

See p. 142 (UCI 6).

Kroin: Architectural Complements

See p. 146 (UCI 10).

Metropolitan Furniture Corporation

Catalogs feature Robert Long Lights, \$15, and the Metropolitan contract and residential furniture, \$25. A 35-milimeter slide show on Metropolitan furniture as well as Robert Long is available. The company also has a slide show on the Series 10 seating system for high traffic, contract use.

Contact Alycia Umemoto, Manager, Marketing Services, Metropolitan Furniture Corporation, 950 Linden Ave., South San Francisco, Calif. 94080.

Panel Concepts, Inc.

See p. 150 (UCI 10).

Rangine Corporation

Offers a brochure on Rakks architectural shelving system.

Contact Rangine Corporation, 14 Felton St., Waltham, Mass. 02154.

R. C. Musson Rubber Co.

Catalog describes the company's rubber and vinyl mats, mattings and aluminum mat frames.

Contact R. C. Musson Rubber Co., 1320 E. Archwood Ave., Akron, Ohio 44306.

R-Way Furniture Co.

Catalogs depict the complete line of Skagen office furniture, crafted in select red oak veneers.

Contact R-Way Furniture Co., 740 South Commerce St., Sheboygan, Wis. 53081.

Steelcase Inc.

The three-day Workstation Planning seminar is designed to acquaint office planners with the latest planning concepts and furniture available. \$100. The three-day Service and Installation seminar instructs on how Steelcase furniture is built, how to install it properly and how to service and maintain it. \$150.

Contact C. E. Halterman, Sales Promotion Supervisor, Steelcase Inc., Grand Rapids, Mich. 49501.

Thonet

Offers audiovisual presentations on the firm's history and a presentation by designer David Rowland featuring the new Sof-Tech Stack chair. Brochure also available on the firm's history. G & W Healthcare division's new 181 system, an electric bed, overbed table and bedside cabinet, is featured in another brochure. This fall, two books will be available: *Thonet: A History 1830-1980*, published by Barron's, and a reprint of Thonet's 1904 catalog, published by Dover publications.

Contact Peggy McFadden, Marketing Assistant, Thonet, 491 E. Princess St., P.O. Box 1587, York, Pa. 17405.

Vecta Contract

Offers product brochures, templates and a corporate slide presentation.

Contact Communications Manager, Vecta Contract, 1800 S. Great Southwest Parkway, Grand Prairie, Tex. 75051.

Willamette Industries, Duraflake Division

The literature packet includes actual samples and technical specifications on a UL fire-rated particle board for Class I applications. Machineable, it is a substrate for all types of wood veneers, laminates, vinyls, etc., for wall systems, furniture and fixtures.

Contact Bruce Palmer, Assistant Sales Manager, Duraflake Division, Willamette Industries, Inc., Box 428, Albany, Ore. 97321.

UCI 13: Special Construction

Armco

Catalog presents structural, acoustic and esthetic design details, as well as high-lighting installation and maintenance procedures, of the Armco Noise Barrier system.

Contact Armco Promotional Services, Marketing Center, Department GEN-8679, P.O. Box 600, Middletown, Ohio 45043.

Armstrong World Industries, Inc.

"Lighting for the Office of the '80s" is a 12-minute movie evaluating ambient, task and ambient/task methods of providing high quality illumination at low energy.

Contact Armstrong World Industries, Inc., Architectural Ceiling Systems Division, Box 3001, Lancaster, Pa. 17604.

Chevron U.S.A. Inc.

Offers publications detailing construction specifications and product information for tennis court construction and lighting, and also for synthetic running track construction.

Contact William C. Bradshaw, Special Products, Chevron U.S.A. Inc., Asphalt Division, P.O. Box 7634, San Francisco, Calif. 94102.

Data Processing Security, Inc.

Offers brochures on the latest in safety and security design for computer center facilities.

Contact Data Processing Security, Inc., 200 E. Loop 820, Fort Worth, Tex. 76112.

E. I. du Pont de Nemours & Co.

See p. 140 (UCI 6).

continued on page 154

**What would you get
if you tossed away
all your ideas about
what a building
should be?**

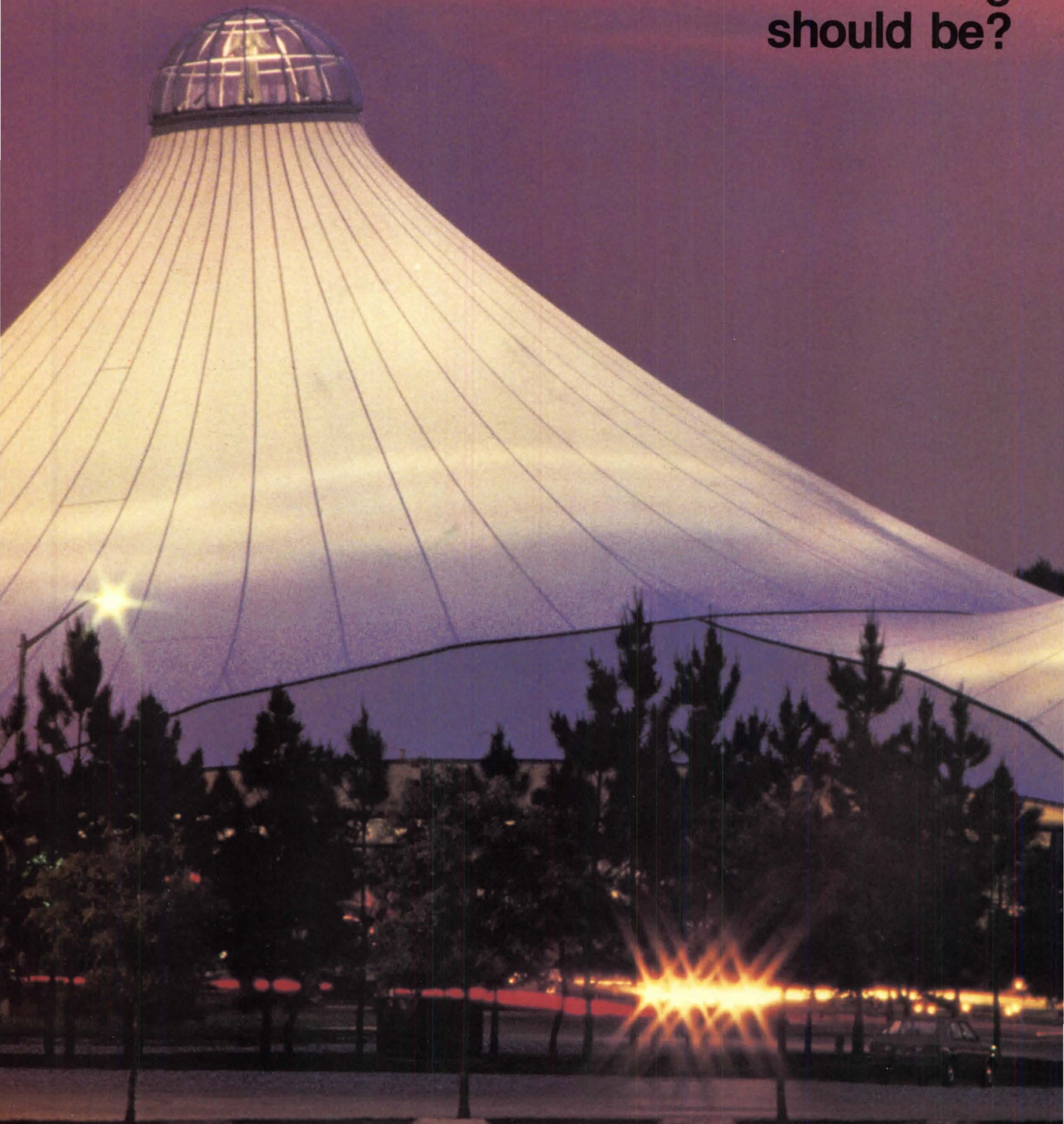

Permanent fabric architecture from Birdair Structures.

A proven, durable system that offers an exciting alternative to traditional construction methods — and a freedom of design and conceptual versatility never before possible. Not just a wide span roof, but a complete environmental envelope that provides translucency, solar reflectivity, and esthetics. Simply put, a revolution in architectural form.

Florida Festival, a 60,000 square foot shopping and entertainment center at Sea World in Orlando, was fabricated and erected by Birdair Structures. The 90,000

square foot roof is made of SHEERFILL[®], CHEMFAB's architectural fabric of fiberglass coated with TEFLON*. With 18% solar transmission, it permits the growth of 40 foot palm trees and other tropical flora. Natural daylight bathes the interior to highlight merchants' products. The high reflectivity of SHEERFILL creates a cooler interior under the hot Florida sun, providing substantial energy savings through greatly reduced air-conditioning requirements.

The design and erection of permanent fabric structures require the specialized skills of a company with the demonstrated ability to help translate vision into reality. Birdair Structures is the pioneer and leader in this field. We invented the technology. Extensive involvement

in virtually every permanent fabric structure built to date makes us uniquely qualified to offer state-of-the-art structural analysis and detailing assistance to the architect. We are the **only** single source that can offer integrated expertise in every phase of fabric structure technology: design, engineering, weaving, coating, fabrication, and erection.

Bring **your** new ideas to us, **Birdair Structures**, a division of CHEMFAB, 2015 Walden Avenue, Buffalo, New York 14225 U.S.A. (716) 684-9500 Telex: 91-353 Cable: Birdair Buffalo.

BIRDAIR STRUCTURES
A DIVISION OF **CHEMFAB**

Architect: Robert Lamb Hart, Architects and Planners, New York, New York
Partners in Charge: Robert Lamb Hart, Basil H.M. Carter
Engineering Consultants: Geiger-Berger Associates, New York, New York

© SHEERFILL is a registered trademark of CHEMFAB

* Du Pont's registered trademark for its fluorocarbon resins and film

UCI from page 151

Helios Tension Products, Inc.

Tension membrane and air-supported structures are designed, engineered, fabricated and installed by the company, and literature is available explaining the products and services.

Contact Motonobu Nohmura, President, Helios Tension Products, Inc., 1602 Tacoma Way, Redwood City, Calif. 94063.

Interface Flooring Systems

Brochure discusses three basic floor-related energy distribution systems: underfloor ducts or cells, raised panel flooring and flatwire. The manual describes each system and discusses the relationship with the Interface product.

Contact Interface Flooring System, Marketing Group, P.O. Box 1503, LaGrange, Ga. 30241.

Owens-Corning Fiberglas Corporation

"Creating New Environments With Fiberglass Fabric Structures" illustrates the practical and esthetic benefits of fabric structures. Both air supported and tension structures are described.

Contact J. D. Stillwell, AIA, Owens-Corning Fiberglas Corporation, Fiberglas Tower, Toledo, Ohio 43659.

Stevens Metallurgical Corporation

Offers information on X-Ray Lead Plate Glass.

Contact Stevens Metallurgical Corporation, 342 Madison Ave., New York, N.Y. 10017.

UCI 14: Conveying Systems

Dover Corporation, Elevator Division

"Modernization Could Be the Answer" describes how, in many cases, some of the existing equipment can be retained so that the cost is much less than for a new elevator. Discusses building character, population density and expected changes, peaks and valleys of elevator usage and similar performance and service requirements.

Contact Modernization Department, Dover Corporation, Elevator Division, P.O. Box 2177, Memphis, Tenn. 38101.

Richards-Wilcox Manufacturing Co.

Materials Handling Equipment catalog describes the company's line of basic monorail systems and cranes, manual and powered overhead chain conveyors, ultra-modern power and free systems.

Contact Paul E. Baudouin, Advertising Manager, Richards-Wilcox Manufacturing Co., 174 3rd St., Aurora, Ill., 60507.

Schindler Haughton Elevator Corporation

Will provide elevator planner and budget

estimator. Also available is a catalog describing 1980 designer series programmable elevators and escalators, with requirements for handicapped, selection, budget pricing, esthetics, options, maintenance/service and design layouts.

Contact Schindler Haughton Elevator Corporation, P.O. Box 780, Toledo, Ohio 43695.

Westinghouse Elevator Co.

Moduline 100 Architect/Contractor Planning Guide contains escalator design details on clear acetate overlays. Construction details are also provided.

Contact Suzy Weiss, Marketing Communications, Westinghouse Elevator Co., 21 Bleeker St., Millburn, N.J. 07041.

UCI 15: Mechanical

Ceramic Cooling Tower Co.

Brochure describes the company's line of airconditioning cooling towers.

Contact Ceramic Cooling Tower Co., P.O. Box 425, Fort Worth, Tex. 76101.

Eljer Plumbingware

Information available on watersaving fixtures and fittings: tank and flush valve closets, urinals, faucets and shower heads.

Contact Eljer Plumbingware, Wallace Murray Corporation, 3 Gateway Center, Pittsburgh, Pa. 15222.

Environmental Elements Corporation

Brochure describes Titus Enviro-Master, a new variable volume air flow assembly designed to save energy while increasing indoor comfort.

Contact Environmental Elements Corporation, Air Cleaning Systems Group, 1221 International Parkway, Richardson, Tex. 75081.

Grinnell Fire Protection Systems Co., Inc.

Technical catalog describes the firm's line of sprinklers, nozzles, valves and accessories.

Contact Grinnell Fire Protection Systems Co., Inc., 10 Dorrance St., Providence, R. I. 02903.

Space/Time Designs, Inc.

Offers *Let's Reach for the Sun*, a 140-page book containing basic information on solar design and application, and floor plans and renderings for 30 solar home designs, \$9.95.

Contact Space/Time Designs, Inc., P.O. Box 4229, Bellevue, Wash. 98009.

Sunmaster Corporation

Offers a brochure describing its evacuated tube solar collector system for heating and cooling. Will also provide consulting services on sizing and specing solar plus microprocessor energy management.

Contact Keith Martin, Sales Manager,

Sunmaster Corporation, 12 Spruce St., Corning, N.Y. 14830.

Youngstown Design Center

The CAIT Fireplace-Boiler is a prefabricated open fireplace capable of heating water for space heating or domestic use. A descriptive catalog is available.

Contact Youngstown Design Center, 435 Main St., Youngstown, N.Y. 14174.

UCI 16: Electrical

Atelier International, Ltd.

Specification sheets available on the firm's latest lighting designs: Frisbi Pendant Lamp, Papillona Floor Lamp and Bollo Wall Lamp.

Contact Atelier International, Ltd., 595 Madison Ave., New York, N.Y. 10022.

Best Manufacturing Co.

Offers information on Graphic Blast process, in which graphics for control panels and distribution systems can be reproduced from black and white artwork and engraved into the surface and paint filled, screen painted or raised by overlays.

Contact Best Manufacturing Co., 3214 Troost, Kansas City, Mo. 64109.

Columbia Lighting

Offers a full-line fluorescent catalog with special brochures on Parabolume, P2, Air-Handling, SuperTube, Form 4 and other designer lighting.

Contact Columbia Lighting, T.A. Box 2787, Spokane, Wash. 99220.

E. A. Nord Co.

Spindle catalog shows nine designs of wood turnings, provides complete size information and reference to matching rails for easy installation as room dividers, stair railings and other decorative applications.

Contact Carol Troto, E. A. Nord Co., P.O. Box 1187, Everett, Wash. 98206.

E. I. du Pont de Nemours & Co.

Brochure discusses the advantages of using plenum cable insulated and jacketed with FEP fluorocarbon resin.

Contact E. A. Browning, Marketing Communications Department, WT-702, Du Pont Co., Wilmington, Del. 19898.

Gardco Lighting

Will supply a number of publications containing technical and engineering data, design templates and computer verifications for outdoor, indoor and custom lighting equipment. Catalogs are available covering lighting design and specifications for new construction and renovation projects.

continued on page 156

CROWD PLEASER.

**Moving people in style. Saving energy.
That's the Westinghouse Moduline 100™ escalator.**

Pleasing big crowds is the specialty of the Park Place Casino Hotel in Atlantic City. And of the Westinghouse Moduline 100 escalator.

Customers were impressed with the dynamic looks of this "Stairway to the Stars" and its spectacular 90-foot glass balustrade.

Hotel managers liked its ability to move a lot of people quickly. Efficiently.

And the quick, trouble-free installation meant the

Bally Corporation, owner of this showplace, could open for business sooner. And win in the big race for new business in the "new Las Vegas."

But like building owners and operators all across America, Bally will also be pleased with the substantial energy savings these escalators provide.

Independent tests showed the Moduline 100 saved 30% over conventional escalators going up

and a whopping 59% going down with only five passengers. And with more people the savings were even greater.

How does Westinghouse do it?

With a unique one-design concept. Modular units, each with a separate motor and drive, can be interconnected. So you can span a vertical rise to almost limitless height. Separate, parallel, criss-cross or even stacked arrangements are possible. And the compact design reduces the need for

massive machine rooms. Building space opens up. That's real design freedom!

To find out more about these people-pleasing people-movers write: Westinghouse Elevator Company, Dept. 802, 21 Bleeker Street, Millburn NJ 07041.

Circle 66 on information card



**The technical leader
in people-moving systems.**



Heart attack or stroke could knock you down on your way up.



You're working for the challenge, the satisfaction, the success. The last thing you want is a heart attack or stroke. Yet, nearly one million Americans die of heart disease and stroke every year. And 200,000 of them die before retirement age.

The American Heart Association is fighting to reduce early death and disability from heart disease and stroke with research, professional and public education, and community service programs.

But more needs to be done.

You can help us find the answers by sending your dollars today to your local Heart Association, listed in your telephone directory.

**Put your money where
your Heart is.**



UCI from page 154

Contact James W. Smith, Vice President Marketing, Gardco Manufacturing, Inc., 2661 Alvarado St., San Leandro, Calif. 94577.

GF Business Equipment, Inc.

"The Quality of Light, A Contemporary Approach to Ambient/Task Lighting" describes the evolution of office lighting, products available from GF and their benefits and applications.

Contact Cindy Booty, Advertising Coordinator, GF Business Equipment, Inc., 229 E. Dennick Ave., Youngstown, Ohio 44501.

Johns-Manville Sales Corporation

Offers reference guide featuring performance data on the eleven variations of Controlens fluorescent lenses. Also available is a brochure describing the features and advantages of the Parkpak luminaire. Contact Johns-Manville Service Center, 1601 23rd St., Denver, Colo. 80216.

Kim Lighting, Inc.

The Low Level Floodlight is introduced in an eight-minute film. Area lighting without the use of poles is demonstrated, along with applications, performance, energy savings and stairway lighting.

Contact Doug Paulin, Assistant Sales Manager, Kim Lighting, Inc., 16555 E. Gale Ave., City of Industry, Calif. 91789.

Peerless Electric Co.

Presents four literature selections: a 100-page booklet depicting optics, candle-power distributions, coefficients of utilizations and application data and services for Longlite linear fluorescent lighting systems; a catalog of different design choices; a 38-page analysis of seven leading lighting systems in classroom lighting, and a 30-page brochure presenting seven alternative lighting systems for library stacks.

Contact Craig Bernecker, Project Coordinator, Peerless Electric Co., 747 Bancroft Way, Berkeley, Calif. 94710.

Thomas & Betts

Offers information on Versa-Trak flat-conductor cable system for electrical distribution in open office landscape.

Contact Thomas & Betts, 920 Route 202, Raritan, N.J. 08869.

Victor Manufacturing Co., Inc.

Catalog describes the firm's product line including oak strip lights, redwood garden lanterns, redwood walkway lights, interior redwood fixtures, redwood strip lights, among others.

Contact Yvonne Victor, Sales Manager, Victor Manufacturing Co., Inc., 1045 Terminal Way, San Carlos, Calif. 94070 □

Future Shock!

age	65
years	40
worked	<hr/>
retirement	0
benefits	

Many of the 50 million Americans who are covered by private pension plans think they'll automatically qualify for benefits when they reach retirement age.

They're wrong!

Every plan has requirements that must be met under the Employee Retirement Income Security Act. And the time to find out about those requirements is now—even if retirement is 30 years down the road.

There's a lot more to think about too. Does your plan permit early retirement? How much will your plan pay you? Will you receive a monthly payment or a lump sum?

The U.S. Department of Labor has a free booklet that will help you answer these questions and a lot more. Send for it today.

Write:

Pensions, Consumer Information Center
Pueblo, Colorado 81009

U.S. Department of Labor



The
Annua
Of
Amer
Archit
1980

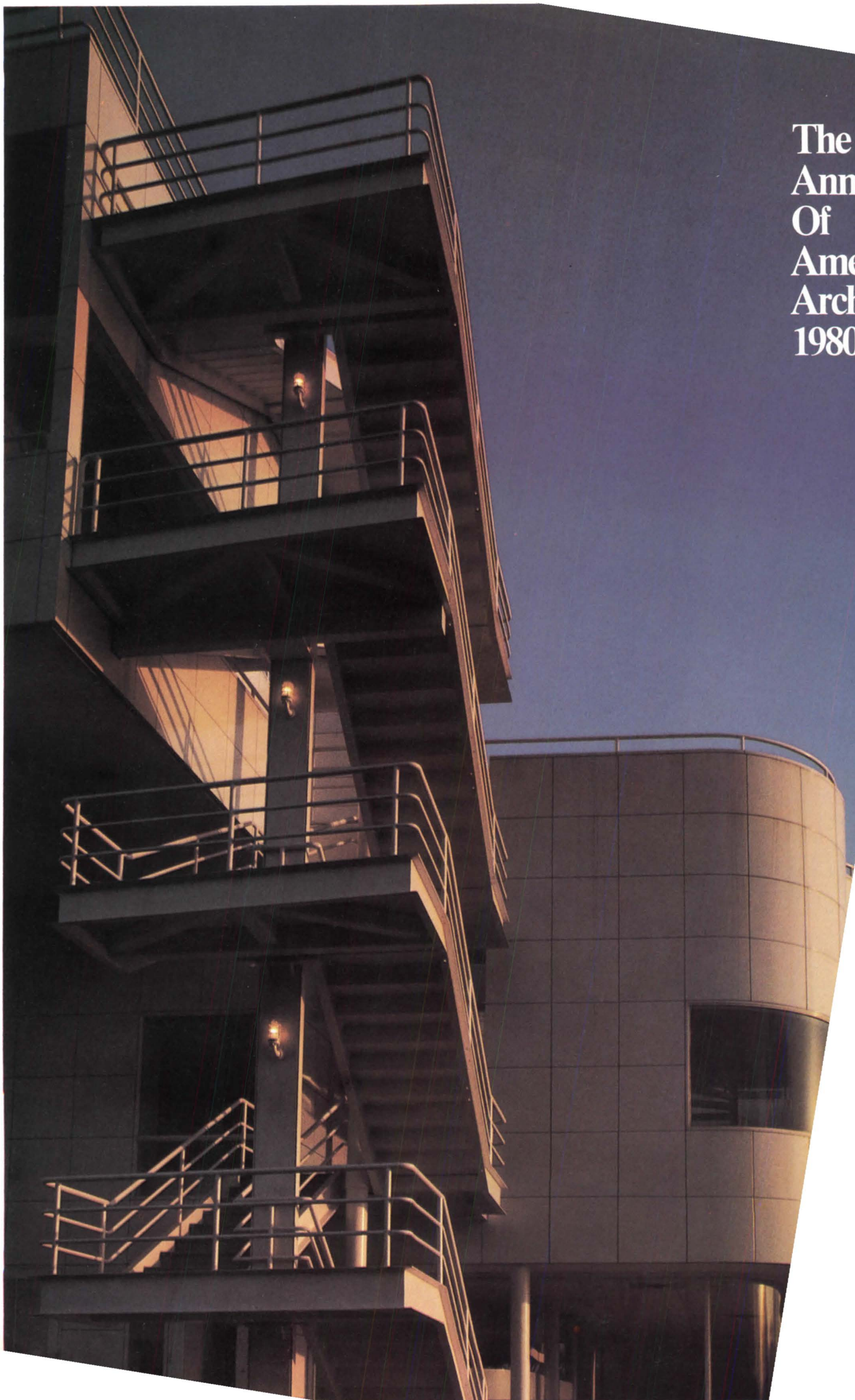

The Annual of American Architecture 1980

Here, for the first time, is the only publication in permanent form which brings together the most significant recent buildings in American architecture

Three years ago, the AIA JOURNAL published its first annual review of new American architecture. Until then, anyone wanting to keep up with the best of what was being built in America and chart directions in architectural design had two basic choices: read at least the three major American architectural magazines regularly, and perhaps some foreign ones as well; read book-length collections of buildings, usually of single types (houses, factories, etc.), not all of which were anywhere near new.

The JOURNAL's review brought together for the first time a representative sampling of new buildings of all types between a single set of covers; together with observations of prominent architects, critics and historians in architectural design.

The Annual of American Architecture 1980 puts the JOURNAL's annual review between hardcovers for the first time. This beautifully illustrated, four-color book is designed for both the lay and professional reader—a handsome addition to the home or office library. Why not buy extra copies for those friends who “have everything.” They won't have this—yet.

To order, simply fill out the coupon below and send in, with your check payable to AIA.

Please send _____ copies of The Annual of American Architecture 1980
(#2M725) @ _____ \$19.95 non-member price
_____ \$16.00 AIA member price

All orders must be prepaid. District of Columbia residents add 5% sales tax. Foreign orders must be paid in U.S. dollars and include postage in the amount of 20% added to dollar amount of order. Total enclosed \$_____.

Send to: Director/Publication Sales
The American Institute of Architects
1735 New York Avenue, N.W.
Washington, D.C. 20006

FIRM _____

ATTENTION _____

ADDRESS _____

CITY, STATE, ZIP _____

ADVERTISERS

Michael J. Hanley
 Publisher
Michael M. Wood
 National Sales Director
George L. Dant
 Manager, Production and Business
 1735 New York Ave. N.W.
 Washington, D.C. 20006
 (202) 626-7484
Lisa Hoke
 Director of Operations
Suzanne Maggi
 Administrative Assistant

ADVERTISING SALES OFFICES

Washington, D.C. (202) 626-7471

Michael M. Wood
 1735 New York Ave. N.W.
 Washington, D.C. 20006

New York (201) 729-4937

Thomas R. Crow
 46 Main Street
 Sparta, N.J. 07871

New England/New York State

(617) 632-8185

Robert L. Tagen
 87 State Road West
 Westminster, Massachusetts 01473

Chicago (312) 887-1171

Robert M. Brown
 201 E. Ogden Avenue
 Hinsdale, Illinois 60521

St. Louis (314) 569-3210

Richard D. Grater
 1466 Summerhaven
 St. Louis, Missouri 63141

San Francisco (415) 348-8222

Jules E. Thompson
 1290 Howard Avenue #303
 Burlingame, California 94010

Alma Desk Company	19	King Faisal University	
<i>Long, Haymes & Carr</i>		Saudi Arabian Mission	130
Aluminum Company of America ..	141	Kohler Company	70
<i>Creamer, Inc.</i>		<i>Campbell-Mithun</i>	
American Gas Association	10	Kroin	7
<i>J. Walter Thompson</i>		<i>Architectural Complements</i>	
Andersen Windowalls	146-147	Levolor Lorentzen	Cov. 3
<i>Campbell-Mithun</i>		<i>Muller, Jordan, Weiss</i>	
Artistic Tiles Manufacturing, Inc. .	64	Libbey-Owens-Ford (LOF)	12-13
Astie Art Metal Studio	128	<i>Campbell-Ewald</i>	
Belden Brick	48	Library Bureau	18
<i>Frease & Shorr Advertising</i>		<i>Barlow/Johnson</i>	
Brick Institute of America ..	69-71-73	Lumina, Inc.	73
<i>Henry J. Kaufman & Assoc.</i>		<i>M. M. Buckner, Graphic Design</i>	
Cabot, Samuel, Inc.	123	Mecanoids, Inc.	130
<i>Donald W. Gardner Adv.</i>		Medusa Cement Co.	121
Carpenter, L. E. Co.	113	<i>Hayden Stanford</i>	
<i>The Siesel Co.</i>		Mondo Rubber Canada, Ltd.	68
Chemfab/Birdair Structures		<i>Corporation Publi-Com. Inc.</i>	
Division	152-153	Nucor (Vulcraft)	8-9
<i>Woodward Askey Eggers & Schaffer,</i>		<i>Faller, Klenk & Quinlan</i>	
<i>Inc.</i>		Olympic Stain	Cov. 4
Cheney Flashing Co.	126	<i>Kraft Smith</i>	
<i>MR Associates</i>		Otis Elevator Co.	34-35
Columbus Coated Fabrics	33	<i>Poppe Tyson</i>	
<i>Lord, Sullivan & Yoder</i>		Owens-Illinois (Sunpak)	20-21
Consolidated Aluminum	44-45-46	<i>Howard Swink Advertising</i>	
<i>Weitzman Dym & Associates</i>		Pen Ply	142
CYRO Industries	72	<i>Soderberg, Thompson, MacEwan</i>	
<i>Hazard Advertising</i>		Proudfoot Company	124
Data Processing Security	125	<i>Harrison House</i>	
<i>Advertising Consultants</i>		Revere Copper and Brass, Inc. ...	55
Dow Chemical Co.	22-23	<i>Kornhauser & Calene</i>	
<i>Campbell-Mithun</i>		R-Way Furniture Co.	69
Dryvit System, Inc.	118-119	<i>R-Way Advertising</i>	
<i>Fren/Hanaway</i>		Schinnerer, Victor O. & Co.	14
Eckel Industries, Inc.	71	<i>Govatos/Dunn</i>	
<i>Susan E. Schur</i>		Shakertown Siding	59
Geberit Manufacturing, Inc.	28	<i>Gerber, Meyers, Wolf & Kilgore</i>	
<i>Boger, Martin, Fairchild & Co.</i>		Shand, Morahan Company	1
Gold Bond Bldg. Prod. Div.		<i>Hakanson & Associates</i>	
Nat'l. Gypsum Co.	56	Stern-Williams	128
<i>Faller, Klenk & Quinlan</i>		<i>Ad Mar Co.</i>	
Grefco (Permalite)	6	Thiokol Corporation	74
<i>Boylhart, Lovett & Dean</i>		Unistrut Interior Bldg. Systems ..	41
Grinnell Sprinkler System	49	<i>Hedlund & Associates</i>	
<i>Hutchins/Y&R</i>		United Sheet Metal	11
Haws Drinking Faucet Co.	27	<i>Bannerman Industrial Advertisers</i>	
<i>Mandabach & Simms/Pacific</i>		United States Ceramic Tile	36
Howmet Aluminum Corp.	Cov. 2	<i>Covey & Koons</i>	
<i>Crume & Associates</i>		United States Gypsum	47
ITT Outdoor Lighting	65	<i>Marstrat, Inc.</i>	
<i>John Malmo Advertising</i>		Welsbach Lighting	129
Johns-Manville (Bldg. Systems		<i>Langler: Mason</i>	
Div.)	30-31	Western Electric Co.	38-39
<i>Broyles, Allebaugh & Davis</i>		<i>Foote, Cone & Belding</i>	
Kawneer Architectural Products ..	4-5	Westinghouse Elevator Company .	155
<i>Garrison, Jasper, Rose & Co.</i>		<i>Marsteller, Inc.</i>	
KDI Paragon	127	Weyerhaeuser Company	50-51
<i>Lloyd S. Howard Assoc.</i>		<i>Cole & Weber</i>	

Galaxy Sun Controllers

Riviera Blinds



We challenge you to find a sun control system this beautiful.

Levolor has come up with a glare-and-temperature control system for large expanses of glass that dramatizes your original design instead of detracting from it. Overhead, Levolor Galaxy™ Sun Controller blinds redirect the sun's rays, for minimum glare, maximum summer cooling, maximum winter warmth. Used with Riviera™ blinds by Levolor at the window, as shown here, you have a total sun control system that

is a visual plus, easy to install and engineered with Levolor technological standards—the highest. A system that can be operated automatically or manually. The beautiful answer to odd-shaped, hard-to-reach special glazing situations. Our Levolor architectural consultant can answer your specific questions. Write for information: Levolor Lorentzen, Inc.,

720 Monroe Street,
Hoboken, N.J. 07030.

LEVOLOR®

Sun Controller Systems.
A product of Levolor Lorentzen, Inc.

Circle 70 on information card



Beauty that's more than skin deep.



Architect: Wendell Lovett, FAIA, Seattle, Washington

Enhance and protect the natural beauty of wood with Olympic Oil Stain. Olympic *penetrates* wood to protect from within. Rich linseed oil and micro-milled pigments soak down into the fibers, giving wood a deep, uniform finish that stays beautiful no matter how wet or how dry the weather gets.

For additional information, consult your 1979 Sweet's Catalog. Or write Olympic: Dept. P, P.O. Box 1497, Bellevue, WA 98009.

**Penetrates to
protect wood
beautifully.**



Circle 71 on information card