



ARCHITECTURAL RECORD

12 *December 1961*

Building Types Study: Hospitals

Space-Framed Administrative Center by SOM

A Church for the Deaf by Rapson

Semi-Annual Index

Full Contents on Pages 4 & 5

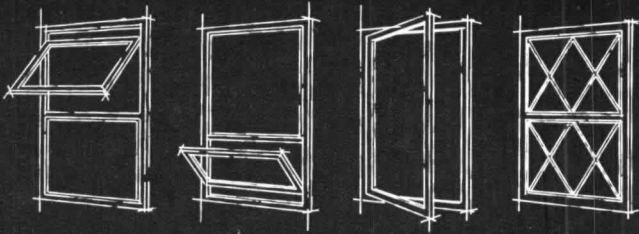

4-WAY
Qualitybilt
WINDOWS

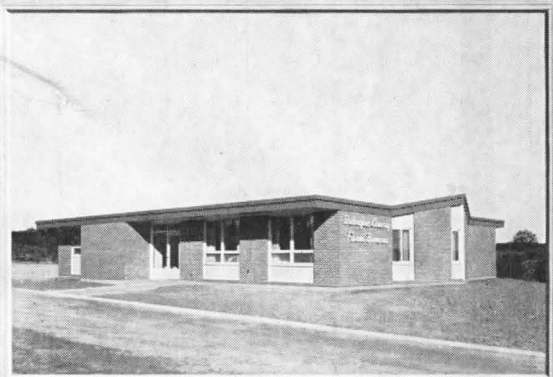
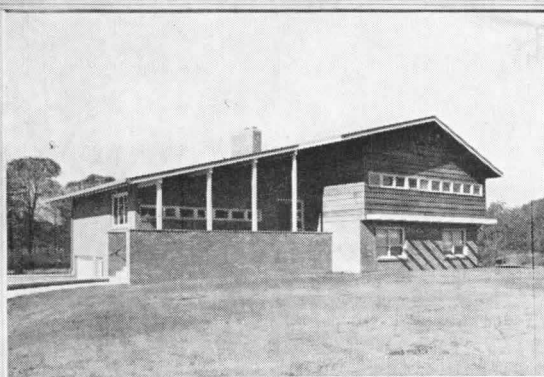
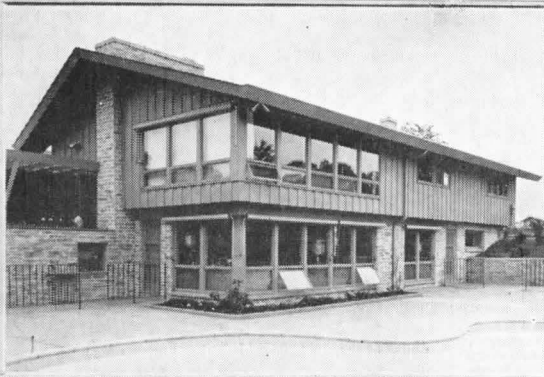

incomparable Qualitybilt 4-Way windows...

Take a good look through the handsomest, most popular window line available . . . Qualitybilt 4-Ways! Right at home in any architectural situation, these versatile units perform flawlessly as Awning, Hopper, Casement, or Fixed windows; fit any type of wall construction. Styled for modern living . . . crafted for a lifetime of service in the famous Qualitybilt tradition, yet priced for modest budgets.

FARLEY & LOETSCHER MFG. CO. DUBUQUE, IOWA

plant
produced

CONCRETE

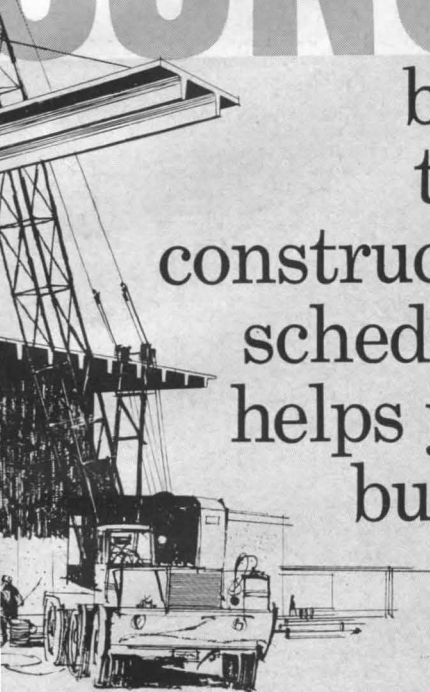

beats
tight
construction
schedules,
helps your
budget

In almost all instances, units are erected directly from truck to structure without stockpiling or rehandling at the site. Prestressed members fit readily in place to speed erection and shorten total construction time.

Check all these advantages:

LONG SPANS, SHALLOW DEPTHS ... for fewer columns, more usable floor space. High strength produced by prestressing allows the design of well proportioned members of limited depth for given spans.

CUTS CONSTRUCTION TIME - Plant manufacture of prestressed members and site work proceed simultaneously to shorten job schedule.

FINISHED PRODUCT OF PLANT CONTROLLED QUALITY - A wide range of architectural and structural shapes meeting PCI and AASHO requirements are available at local plants for buildings, bridges and foundations.

FIRE RESISTANT - Tests have proven the high fire-resistant quality of prestressed concrete.

ATTRACTIVE APPEARANCE - FLEXIBLE IN DESIGN - Can take a variety of aesthetically agreeable shapes and bold new designs. Refined prestressed designs result in lighter weight structures.

LOW INSURANCE COST - Durability and fire resistance mean low insurance premiums.

MAINTENANCE-FREE - Requires no painting, little or no waterproofing. Needs no protection from corrosion.

LOW INITIAL COST - Design flexibility, quality plant production and short construction time mean superior structures for less money.

PRESTRESSED CONCRETE INSTITUTE

205 WEST WACKER DRIVE • CHICAGO 6, ILLINOIS

Gentlemen: Please send me your free report "Prestressed Concrete - Applications and Advantages." R12

NAME _____
 POSITION _____
 FIRM _____
 ADDRESS _____
 CITY _____ ZONE _____ STATE _____

PRESTRESSED CONCRETE INSTITUTE

MONTANA Floyd Pappin & Son, Inc., Great Falls
NEBRASKA Nebraska Prestressed Concrete Co., Lincoln • Wilson Concrete Co., Omaha
NEW JERSEY Camco Concrete Corp., Vineland
NEW MEXICO American-Marietta Company, Albuquerque
NEW YORK American-Marietta Company, New York City • American-Marietta Company, Syracuse • Precrete, Inc., Corona • Principiana, Inc., Long Island City • Raymond International, Inc., New York
NORTH CAROLINA Arnold Stone Co., Greensboro • Concrete Materials, Inc., Charlotte • North Carolina Products Corp., Raleigh • Piedmont Construction Co., Winston-Salem • S & G Prestress Co., Wilmington
OHIO American-Marietta Company, Columbus • Concrete Masonry

Corp., Elyria • Concrete Pipe Co. of Ohio, Cleveland • Marietta Concrete, Div. American-Marietta Company, Marietta
OKLAHOMA Oakley Engineering Co., Tulsa
OREGON Builders Supply Co., Medford • Empire Pre-Stress Concrete of Oregon, Portland • Ross Island Sand & Gravel, Portland
PENNSYLVANIA American-Marietta Company, Norristown • Dickerson Structural Concrete Corp., Youngwood • Eastern Prestressed Concrete Corp., Line Lexington • Formigli Corp., Philadelphia • New Enterprise Stone & Lime Co., Inc., New Enterprise • Pennsylvania Prestress, Inc., York • Schuykill Products, Inc., Cressona • Turbotville Block Co., Turbotville
SOUTH CAROLINA American-Marietta Company, Columbia • Ballard-Rice Prestressed Corp., Greenville
SOUTH DAKOTA Gage Bros. Concrete Products, Sioux Falls

TENNESSEE American-Marietta Company, Memphis • Knox Concrete Products, Inc., Knoxville • Nashville Brecko Block Co., Nashville
TEXAS Anchor-Wate Co., Houston • Atlas Structural Concrete, El Paso • Crowe-Gulde Prestressed Concrete Co., Amarillo • Span, Inc., Dallas • Texas Concrete Co., Victoria • Texas Quarries, Inc., Austin
UTAH Utah Prestressed Concrete Co., Salt Lake City
VIRGINIA Concrete Structures, Inc., Richmond • Shockey Bros., Inc., Winchester • Southern Block & Pipe Corp., Norfolk • Virginia Prestressed Concrete Corp., Roanoke • Alexandria Prestressed, Inc., Alexandria
WASHINGTON Associated Sand & Gravel Co., Everett • Central Pre-Mix Concrete Co., Spokane • Concrete Technology Corp., Tacoma
WISCONSIN Concrete Research, Inc., Waukesha • Prestressed Concrete Products Corp., Verona • West Allis Concrete Products Co.,

Milwaukee • Eau Claire Stresscrete, Inc., Eau Claire • F. Hurlbut Co., Green Bay
PUERTO RICO Pacadar Prestressed Beams Corp., San Juan
CANADA Alberta: Con-Force Products Ltd., Calgary • **Manitoba:** Building Products & Coal Co. Ltd., Winnipeg • Supercrete Ltd., St. Boniface • **New Brunswick:** Joseph A. Likely Ltd., St. John • **Newfoundland:** Lundrigan's Concrete Ltd., Corner Brook • **Nova Scotia:** L. E. Shaw Ltd., Halifax • **Ontario:** Murray Associates Ltd., Toronto • Ontario Stresscrete Ltd., Burlington • Pre-Con Ltd., Brampton • Ryan Builders Supplies Ltd., Windsor • Schell Industries Ltd., Woodstock • Standard Prestressed Structures Ltd., Maple • Toronto Cast Stone Co. Ltd., Toronto • Wilson Concrete Products Ltd., Belleville • J. M. Wright Ltd., North Bay • **Quebec:** Francon Ltd., Montreal • Pressure Pipe Ltd., Montreal
This advertisement sponsored by PCI Active Members

Architectural Engineering

INTEGRATING MECHANICAL SYSTEMS 148

A Design Approach
by Gershon Meckler

Describes a radiant system for removing heat from lights and procedure for flexible design of mechanical systems

MODEL TESTS PREDICT SPACE FRAME BEHAVIOR 152

by Kenneth C. Naslund

Test model of Upjohn gave design stresses, checked out by a full-sized prototype

TIME-SAVER STANDARDS 155

Floor Framing Systems
by John Mascioni

BUILDING COMPONENTS 161

Sound Systems
by Robert B. Newman & William J. Cavanaugh
Principal types of loudspeaker arrangements are discussed

PRODUCTS REPORTS 163

OFFICE LITERATURE 164



Cover:

Prince of Peace Lutheran Church for the Deaf,
St. Paul, Minnesota. Ralph Rapson, Architect.
Photo by Warren Reynolds

Advertising Index 270

ARCHITECTURAL RECORD December 1961 Vol. 180, No. 6. Published monthly, except May 1961, when semi-monthly, by F. W. Dodge Corporation, a McGraw-Hill Company.

Executive, editorial, circulation and advertising offices: 119 West 40th Street, New York 18, N. Y. Western Editorial Office: 2877 Shasta Road, Berkeley 8, Calif. Office of Publication, 10 Ferry Street, Concord, N. H.; second-class mail postage paid at Concord, N. H.

Subscription rate for individuals in the field served \$5.50 per year in U. S., U. S. Possessions and Canada; single copies \$2.00, except Mid-May 1961 issue \$2.95. Further details on page 6. Postmaster: Please send Form 3579 to Circulation Manager, ARCHITECTURAL RECORD, 119 West 40th Street, New York 18, N. Y. (National Edition)

ARCHITECTURAL

Record Reports

BEHIND THE RECORD 9

Le Corbusier, Psychiatrist
by Emerson Goble

LETTERS 10

BUILDINGS IN THE NEWS 12

CURRENT TRENDS IN CONSTRUCTION 18

A monthly analysis prepared for the RECORD by Edward A. Sprague, Economist, F. W. Dodge Corporation

CONSTRUCTION COST INDEXES 20

MEETINGS AND MISCELLANY 27

A roundup of professional news

REQUIRED READING 42

CALENDAR AND OFFICE NOTES 198

Architects and Buildings

- ALLEN, REX WHITAKER. Roseville District Hospital, Roseville, Calif.134. With John Carl Warnecke, assoc. archt.: French Hospital, San Francisco136
- ANSHEN & ALLEN. Town House, San Francisco123
- CANNON, THIELE, BETZ & CANNON. Highland Hospital, Beacon, N.Y.138
- RAPSON, RALPH. Prince of Peace Lutheran Church for the Deaf, St. Paul, Minn.111
- SKIDMORE, OWINGS & MERRILL. General Office Building. The Upjohn Company, Kalamazoo, Mich.101
- STEPHENSON & TURNER. St. Frances Xavier Cabrini Hospital, Melbourne, Australia141
- STONE, MARRACCINI & PATTERSON. El Camino Hospital. Mountain View, Calif.128
- URBAHN, BRAYTON AND BURROWS. Downstate Medical Center, Brooklyn, N.Y.144

Authors and Articles

- HAMMOND, PETER. "Recent British Church Design: An Agreement to be Radical"115
- MASCIONI, JOHN. "Floor Framing Systems," Parts 1, 2155
- MECKLER, GERSHON. "Integrating Mechanical Systems; A Design Approach"148
- NASLUND, KENNETH C. "Model Tests Predict Space Frame Behavior"152
- NEWMAN, ROBERT B., AND WILLIAM J. CAVANAUGH. "Sound Systems"161

Features

SPACE-FRAMED ADMINISTRATIVE CENTER 101 *SOM's skillful blend of structural expression, fine detail and notable landscaping results in distinguished architecture for The Upjohn Company*

A CHURCH FOR THE DEAF 111 *An exceptionally nice, low budget church by Ralph Rapson*

RECENT BRITISH CHURCH DESIGN: AN AGREEMENT TO BE RADICAL 115
Peter Hammond, leading British critic of church architecture, singles out recent English churches for praise or blame in terms of adaptation to advanced liturgical thought

A TOWN HOUSE ON A SPECTACULAR SITE 123
Anshen & Allen build a multi-level house to exploit the views of San Francisco

RECORD

CONTENTS
December 1961

Building Types Study 301: Hospitals

INTRODUCTION 127 *Hospitals are being built in record numbers. Hospital architects and engineers continue to innovate, improve, and establish new design trends. Examples of some of the more important trends:*

SPECIAL CARE UNITS 128 *El Camino Hospital*

IMPROVED PATIENT ROOM PLANNING 134 *Roseville District Hospital*

DEVELOPMENT OF SERVICE CORES 136 *French Hospital*

PATIENT CARE ON A SINGLE LEVEL 138 *Highland Hospital*

SIMPLIFICATION OF PLAN 141 *St. Frances Xavier Cabrini Hospital*

RESEARCH AND TEACHING IN A GENERAL HOSPITAL 144 *Downstate Medical Center*

Coming in the Record

ARCHITECTS DESIGN FOR URBAN LIVING

Next month's Building Types Study on Apartments will focus attention on some of the creative contributions architects are making to the design of habitation for city dwellers, and especially principles and practices relating to the successful combination of high- and low-rise units and the effective human use of outdoor space. An article by William J. Conklin, A.I.A., whose firm has had considerable experience with large-scale urban redevelopment projects, will be followed by notable examples of recent work of several architects in this field.

DESIGN FOR FALLOUT PROTECTION

With the Administration urging on the public the necessity of fallout protection, and funds already appropriated for a nationwide survey by architects and engineers of the shelter possibilities of existing buildings, the subject of fallout shelters has suddenly become a hot topic. A six-page article will provide a summary of the latest technical data available for architects and engineers on shelter design.

TEACHING SCIENCE TO ARCHITECTS

The problem of relating developments in building technology to the teaching of architecture has been met at the University of Sydney by the establishment of an "architectural science laboratory" where students perform some 40 experiments on structures, building materials, lighting, acoustics, etc., during a five-year course in architecture. Professor Henry J. Cowan, head of the Department of Architectural Science at Sydney, describes the objectives and methods of the laboratory in an illustrated article in next month's issue.

ARCHITECTURAL RECORD (combined with AMERICAN ARCHITECT and ARCHITECTURE), title ® reg. in U. S. Patent Office, © copyright 1961 by F. W. Dodge Corporation, a McGraw-Hill Company. All rights reserved including the right to reproduce the contents of this publication either in whole or in part. Quotations on bulk reprints of articles available on request. Indexed in Reader's Guide to Periodical Literature, Art Index, Industrial Arts Index and Engineering Index.

Every effort will be made to return material submitted for possible publication (if accompanied by stamped, addressed envelope), but the editors and the corporation will not be responsible for loss or damage.

SUBSCRIPTIONS: Available only by paid subscription. Publisher reserves the right to refuse non-qualified subscriptions. Subscriptions to Architectural Record solicited only from architects and engineers. Position, firm connection, and type of firm must be indicated on subscription orders forwarded to Circulation manager, Architectural Record, 119 West 40th Street, New York 18, N. Y. Subscription prices: U. S., U. S. Possessions and Canada: \$5.50 per year; other Western Hemisphere countries, to those who by title are architects and engineers, \$9.00 per year. Single copy price except Mid-May 1961 issue \$2.00; Mid-May 1961 issue \$2.95. Beyond Western Hemisphere, to those who by title are architects and engineers, \$9.00 per year for 12 monthly issues not including Mid-May 1961 issue. Subscriptions from all others outside U. S., U. S. Possessions and Canada for 12 monthly issues, not including Mid-May issue, \$24.00 per year.

CHANGE OF ADDRESS: Subscribers are requested to furnish promptly both old and new address, sending, if possible, stencil impression from magazine wrapper; new postal zone number, if any, should be included. Allow one month for change.

UNCONDITIONAL GUARANTEE: The publisher, upon written request, agrees to refund the part of the subscription price applying to the remaining unfilled portion of the subscription if service is unsatisfactory.

OTHER F. W. DODGE SERVICES: Dodge Reports—Dodge Construction Statistics—Sweet's Catalog Services—Dodge Books—Dodge Mailing Service—Home Planners' Digest—The Modern Hospital—The Nation's Schools—College and University Business—Hospital Purchasing File—Chicago Construction News—Daily Pacific Builder (San Francisco)—The Daily Journal (Denver)—Real Estate Record & Builders Guide—Dow Building Cost Calculator.

Staff of Architectural Record

EDITOR

Emerson Goble, A.I.A.

SENIOR EDITORS

Jeanne M. Davern, *Assistant to the Editor*
Robert E. Fischer, *Engineering*
James S. Hornbeck, A.I.A., *Features*
William Dudley Hunt, Jr., A.I.A.
Elizabeth Kendall Thompson, A.I.A., *West*

ASSOCIATE EDITORS

Herbert L. Smith, Jr., A.I.A., *Houses*
Mildred F. Schmertz, *Design*
Grace M. Anderson
William B. Foxhall
Anne Keffer, *Production*

CONTRIBUTING EDITOR

Ernest Mickel, *Washington*

ASSISTANT EDITOR

Kathryn Gallant

EDITORIAL ASSISTANT

Jan Rahm

DESIGN

Eugene H. Hawley, *Director*
Alex H. Stillano, *Associate*

CONSULTANTS

Gordon W. McKinley, *Economics*
Clyde Shute, *Statistical*
Clifford G. Dunnells, Jr., *Field Research*
Daniel J. Howe, Jr., *Public Relations*
Sigman-Ward, *Drafting*

PUBLISHER

Robert F. Marshall

EDITORIAL DIRECTOR

Robert M. Cunningham, Jr.

PUBLISHING ADVISER

H. Judd Payne

CIRCULATION MANAGER

Marshall T. Ginn

Officers of F. W. Dodge Corporation

HONORARY CHAIRMAN OF THE BOARD
James McV. Breed

CHAIRMAN OF THE BOARD

Paul Abbott

VICE CHAIRMAN OF THE BOARD

Chauncey L. Williams

PRESIDENT

Irving W. Hadsell

EXECUTIVE VICE PRESIDENTS

Julius T. Little, Robert F. Marshall
T. Oliver Morgan, O. O. Paulsell

EXECUTIVE VICE PRESIDENT AND TREASURER

Howard M. Thompson

VICE PRESIDENTS

Robert M. Cunningham, Jr., William H. Hatch, Jr., Gordon W. McKinley, H. Judd Payne, Richard H. Ray

REGIONAL VICE PRESIDENTS

George H. Atherton, Miles W. Beatty, Carl S. Bennett, Robert G. Bingham, Roy J. Hard, Alton W. Kitchens, Arthur D. Prior

ASSISTANT VICE PRESIDENT AND COMPTROLLER

Edwin H. Freed

ASSISTANT VICE PRESIDENTS

Walter F. DeSaix, Clifford G. Dunnells, Jr., Gault Eastman, Clyde Shute

SECRETARY

John J. Cooke

ASSISTANT SECRETARIES

William C. Breed, Jr., George W. Morgan

ASSISTANT TREASURER

Irving B. Satin

Audit Bureau of Circulations



Associated Business Publications



Le Corbusier, Psychiatrist

In announcing the beginning of construction of the Visual Arts Center, by Le Corbusier, Harvard University has released a short statement by the master which might be said to contain a prescription for curing the ills of the modern mechanized world.

The Center, scheduled to be opened in the fall of 1962, will house, in open flexible space, a number of design workshops "where undergraduates and advanced students will work in a variety of media and materials, and where they will experiment with various aspects of line, form, colors, texture, light and communication." The project recalled to Le Corbusier his own student days and a sort of principle which has remained with him. He wrote to Harvard, in his native French:

"Between 1902 and 1917 Le Corbusier was, in his native country, closely involved in the birth and organization of a special educational section for architectural evolution. Thanks to an exceptional teacher, young and full of initiative (L'Eplattenier), an educational center limited to twenty students, men and women, existed during fifteen years exciting the interest and the hostility of people. In one single place was taught drawing or color, volume, modelling, etc. . . ., construction (furniture, etc.), jewellery, embroidery, etc., etc. . . . Le Corbusier began with a burin in his hand and the goldsmith's hammer and chisel, realizing, though

very young, excellent works. He made his first house when he was seventeen and a half without ever having studied architecture. This house, subjected to the influence of that time and of his teacher L'Eplattenier, gave an opening to architectural decorations: 'scraffiti', mural painting, furniture, wrought iron, embossing, etc. . . . During the following years this school undertook building works (decorative, of course, since it was the fashion at that time): metal, stone, mosaic, stained-glass windows (concert-room, church, fragment of a public edifice, etc. . . .). One day everything collapsed before the rivalry and the hatred which had roused the Old School against this New Section. . . . the manifestation of individualities, the divergencies, finally overcame the enthusiasm.

"And the whole concern collapsed.

"From this first experience Le Corbusier has kept the instinct of the prophetic, indispensable, practical and beneficent relations *between the hand and the head*. The rupture of this collaboration of the hand and the head brought by mechanism and bureaucracy has fomented little by little a monstrous society which would be on the decline if no reaction interfered.

"Harvard University's initiative has therefore found in Le Corbusier a ground which is naturally favorable to the implantation of the ideas which constitute the present programme of this University."

—Emerson Goble

CONTROVERSIES ON BUILDING TECHNOLOGY

Technology of Architecture: Do Schools Reject it?

Your leader (July A.R.) was timely but, alas, few of the leading architects or university professors will stir out of their comfortable chairs to follow you. I'll bet if you mentioned "scientific building research" to the majority of the heads of architectural schools they would cringe as though you had called them a dirty word. You say that "true research in Universities hasn't even come up to the batter's box": how shamefully true! Why? Because they are primarily concerned with teaching *skills* and the programs offered in most of the schools of "architecture" are twenty or even thirty years behind the times.

In the past four years I have contacted practically every architectural school in the U.S., trying to arouse some interest in independent research programs for (1) color and light; (2) sound and acoustics; (3) standards of fireproofing and waterproofing. Not one of them is even vaguely interested. I find many so-called architectural teachers willing to TALK research providing it is in terms of FORM or DESIGN, but none ready to talk seriously about technical building problems. Small wonder that fledging architects leave school with no more mental equipment than the architect of 30 years ago. In fact, were it not for research conducted by industry, the activities of the B.R.C., and for the examples given by architects of other countries, the American architect would be in worse shape than he is. Do you wonder that European or Canadian architects may be ahead? . . .

Truth is that many teachers are completely out of touch with the grubby business of BUILDING and, on the other hand, too many architects would be lost without Sweets Catalog. Now, were YOU serious—or were you just filling up space? If you were serious, I suggest you repeat the theme and challenge the architectural schools to explain why they are so afraid of practical building and experimental technology that they appear to be trying to divorce architecture from building problems!

Herbert D. White
Associate Professor of Architectural Technology
Southern Illinois University

Building-oriented Engineers: Do Architects Welcome Them?

Mr. Goble's comments ("Recognition for Engineers") in the September issue of ARCHITECTURAL RECORD are extremely refreshing, particularly when found in a leading architectural publication. One can only hope that the message will not go unheeded among many of the architectural readers.

While I'm inclined to agree with Mr. Goble that bloodshed is probably not imminent, I've witnessed several conflicts of the type described by Mr. Gamble, where bloodshed would have seemed a milder alternate solution.

I have observed the bartering of architectural "aesthetics" and engineering "practicality" with respect to specific problems, and all too often I've seen a decision by the esthetician which annihilates the possibility of a reasonable engineering solution.

Many architectural designers are so imbued with the idea that an engineer cannot be "building oriented" that they fail to recognize the many who are. Quite often the "building oriented" engineer, once recognized, strikes a note of terror in a number of architectural minds, and the apparent recourse is the well known esthetic veil.

Now after due consideration, I'm convinced that intensive probing of the matter on the pages of the RECORD would be a healthy situation and would be a real service to the readers.

William L. Barnes
Professional Engineer (A.E.)
Grand Junction, Colorado

"Architectural Engineering": Practitioners Want Hearing

The article in the August ARCHITECTURAL RECORD "Technology with Circumspection" by you is most interesting and, I think, most timely.

As an architectural engineer (a graduate in architectural engineering at Pennsylvania State University in 1931, a registered architect since 1939, a professional engineer since 1941 and in practice for myself and in partnership since 1940) I have been fighting for over ten years to have my alma mater maintain a balanced architectural engineering course. By this I mean one in which

the graduate, as his wishes and talents decree, can become a registered architect or a registered engineer or, as in my case, both.

To support me in this project I have been in touch with a number of other graduate architectural engineers. Some are practicing actively only in architecture, some in engineering and others in the combined field. Our major rallying point is that no matter what our present activities, we all feel that the well balanced architecture-engineering curriculum was a very fine education. The architects feel the extra engineering training enhances their abilities to create new and better architecture. Those doing engineering believe you cannot create new and better engineering for buildings without a thorough understanding of the problems of architecture. In the combined field, I can say from my own experiences, it is most gratifying to see a building take shape when you get intimately into all the phases, stages and coordinations as a building grows from the first concept to a worthy structure.

At the present time our group is aware of the activities of many men in our profession who have primarily an architectural background, and as you point out, many in the teaching profession as well, who are doing everything possible to eliminate the A.E. courses, or at least change them so that architectural design will play so minor a role that the student cannot even become a second rate architectural draftsman, let alone a designer. The words of Charles W. Moore in your article express our opinion of this opposition as being due to "discomfort, incomplete understanding, or just plain fear." We are also aware that many of these teachers do everything possible to discourage students from going into or continuing in architectural engineering. It is rather unbelievable, but it appears to be true, that whenever any decisions are to be made pertaining to the architectural engineering curriculum everyone is consulted except the practicing, graduate architectural engineers. We who appreciate the great value of this broad but thorough education are getting fed-up with this attitude.

The art in fine architecture grows
continued on page 224



**CHRIST CHAPEL,
EPISCOPAL ACADEMY,**
Overbrook, Philadelphia, Pa.
Architect: Vincent G. Kling, FAIA;
Sheet Metal Contractor:
Charles M. Wood, Inc.;
Architectural Metals Fabricator:
John G. Leise Metal Works.

Everlastingly distinctive...Anaconda!

Anaconda copper and bronze in the roof and spire of this chapel of contemporary design will give years of service. Furthermore, the years will enhance the beauty of the total concept. Weathering will add an artistic value of its own . . . a natural mellowing patina of soft blue-green.

The batten-seam roof required 24,000 lbs. of 16-ounce cornice temper copper in 24" x 96" sheets. Battens were 2" x 1 $\frac{3}{4}$ " spaced 21 $\frac{1}{2}$ " on centers. The spire was fabricated from bronze and glazed with clear glass.

For complete information on sheet copper and architectural metals in building construction, write Anaconda American Brass Company, Waterbury 20, Conn. In Canada: Anaconda American Brass Ltd., New Toronto, Ontario. 61-727

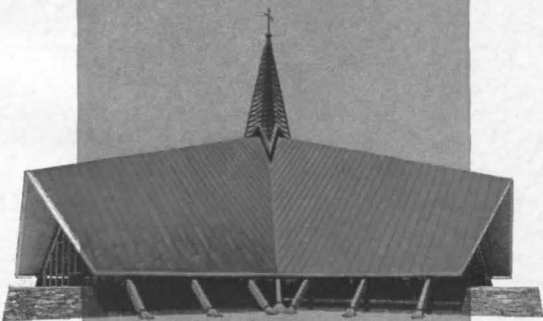

ANACONDA[®]
AMERICAN BRASS COMPANY

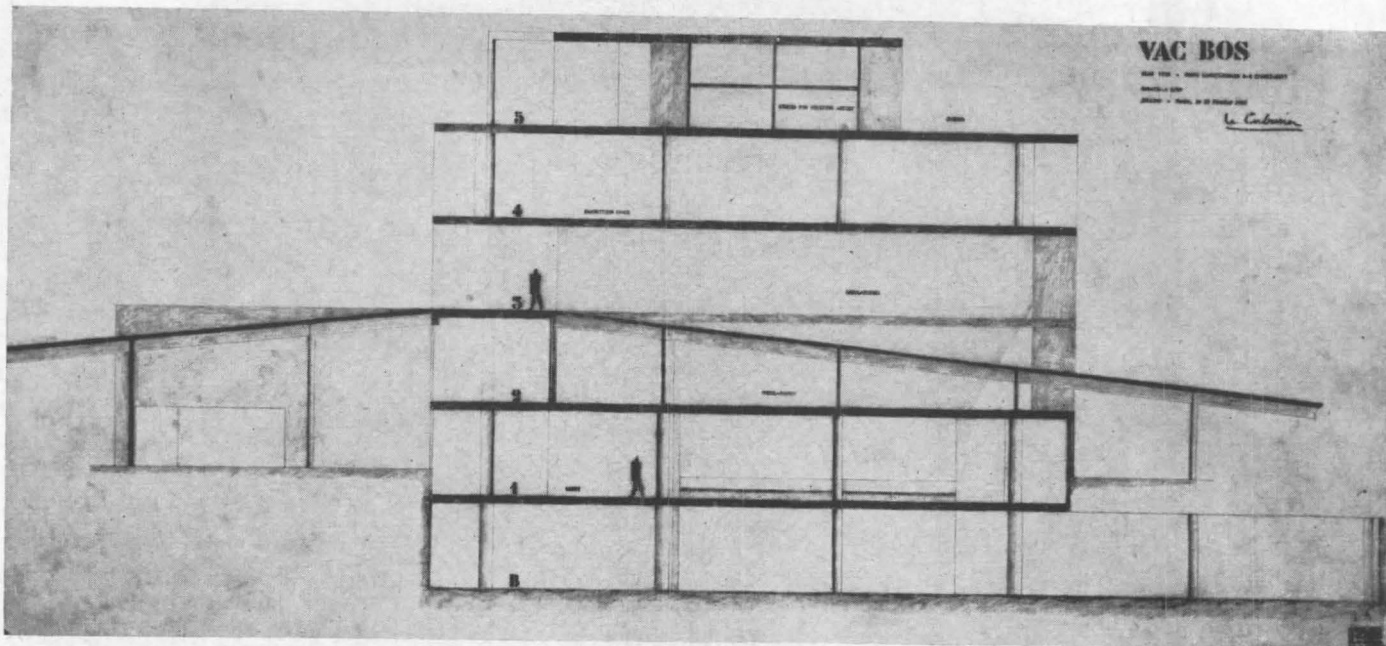

East-west section showing basement and five floors

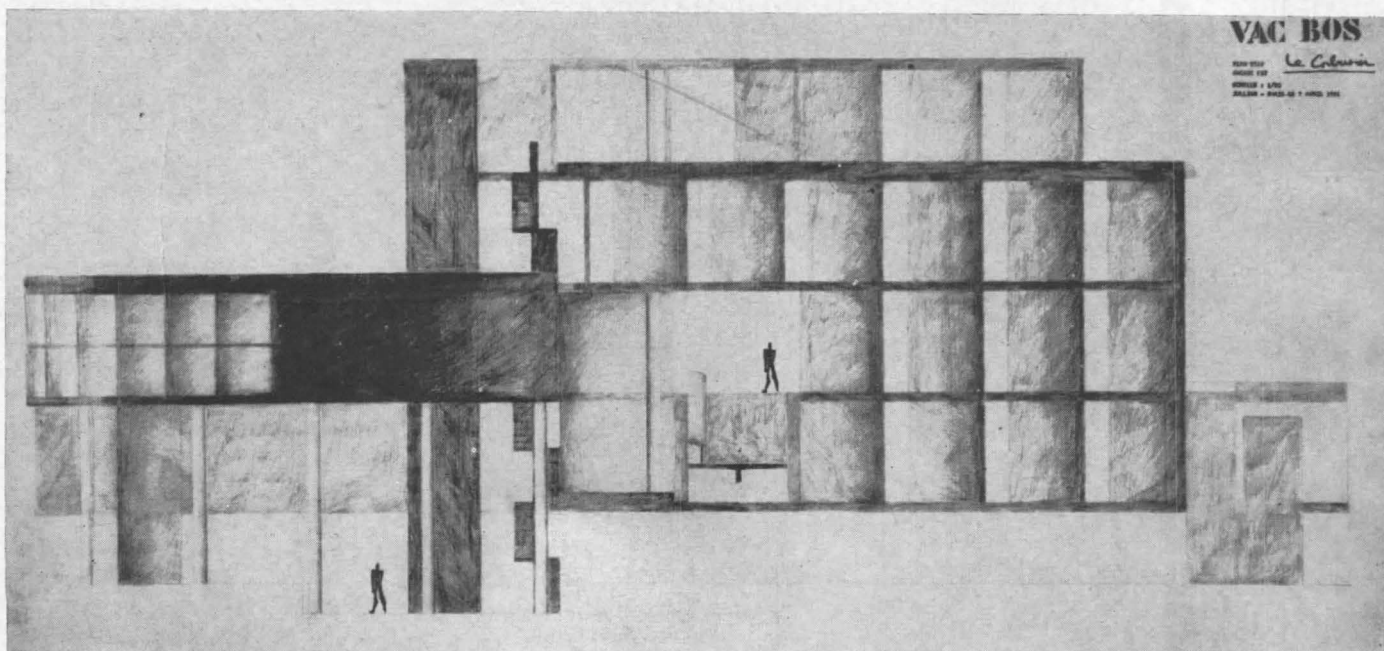

Elevation of the east façade

CORBU DESIGNS HARVARD VISUAL ARTS CENTER

The first American building designed by Le Corbusier will be Harvard University's new Visual Arts Center, scheduled to open the fall of 1962. Containing approximately 50,000 sq ft, the five-level building houses, in open flexible space, design workshops where undergraduates and advanced students will work and experiment in a variety of media and structural materials.

The workshops are separated into three areas: two-dimensional and three-dimensional, with workshops located on the second and third floors; and a workshop devoted to "light and communication" (photography, motion picture, sound, etc.), situated underground with studios and a lecture hall seating 180 students. On the fourth floor,

movable walls will provide for seminars, exhibits and experimental projects. A penthouse on the fifth floor will be used by the director of the Center.

The walls use deep sun baffles that change according to the orientation of the façade and control the natural lighting of the interiors. Large rooms open to roof terraces which provide outdoor exhibit spaces. The building is planned for cross ventilation, with air conditioning only in the lecture hall and special basement workshops.

The Visual Arts Center is the gift of Alfred St. Vrain Carpenter and the late Mrs. Carpenter of Medford, Ore., to the program for Harvard College.

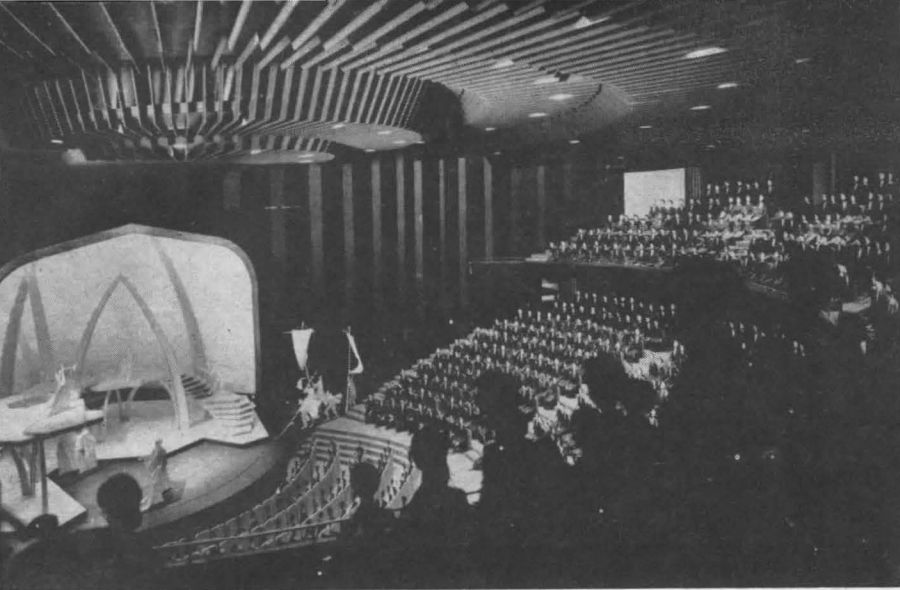

Ezra Stoller Associates

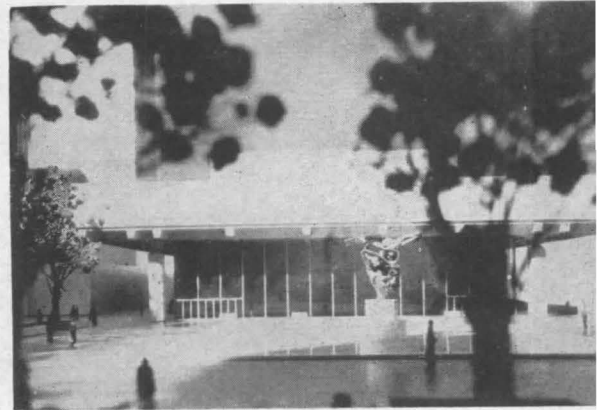

SAARINEN DESIGN FOR LINCOLN CENTER REPERTORY THEATER

The single structure housing the Vivian Beaumont Repertory Theater and the Library-Museum at Lincoln Center was designed by Eero Saarinen Associates with Jo Mielziner as collaborating designer, and Skidmore, Owings and Merrill as associated architects.

The main theater, which seats 1100 persons and contains a stage of 11,000 sq ft, has an air of intimacy which is created through a skillful use of scale. The repeated use of oval curving shapes unifies the stage, main floor, balcony and ceiling.

Aimed at permitting the widest range of possibilities for directing scenery, light and unconventional freedom for actors, the main theater can have a proscenium stage, an open stage of extreme thrust or a combination of the two. Each of the possible arrangements will have the look of permanence. The mechanism which transforms the theater from one with a proscenium to a thrust stage is essentially a giant lift integrated with a turn-table system below stage.

Adolph Studley

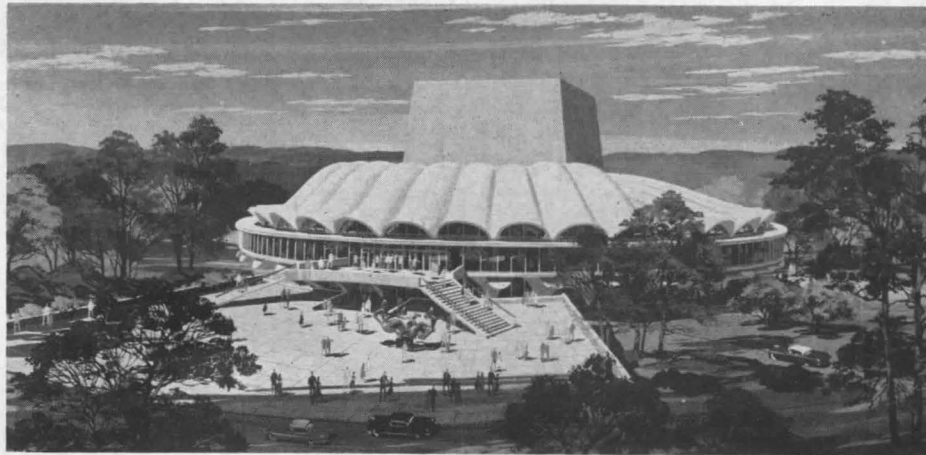

The Nate and Frances Spingold Theater Arts Center at Brandeis University was designed by Max Abramovitz for teaching and performance. Calling for three basic stages—the three-sided platform, theater in the round and end stage, plus the combination of these, the plan provides facilities for rehearsal and dance studios, classroom, seminar and laboratory teaching and allows for expansion, including a painting and sculpture museum.

The Center will occupy a section of the Campus which is a series of natural bowls and stone out-croppings. The service area, with storage, dressing rooms, mechanical equipment rooms and a truck receiving area, is at ground level. Cars move in under the main level overhangs to the lower foyer entrance. Pedestrian approach will be up a ramped plaza and a pair of monumental stairs. Classrooms, seminars, administrative offices surround performing and working sections. Observation and study balconies are on upper level.

SPINGOLD THEATER ARTS CENTER AT BRANDEIS

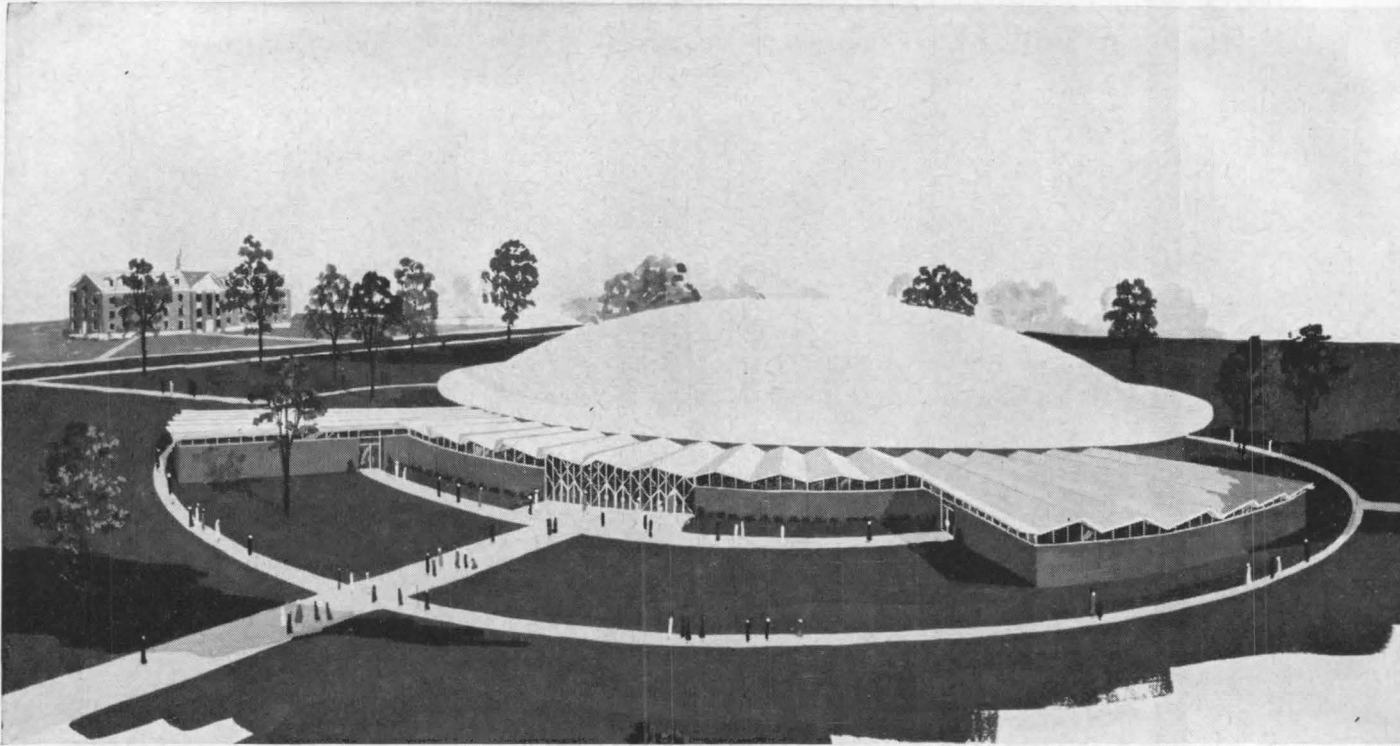

300-ft. concrete dome (reported to be the largest of its type anywhere) is the dominant feature of this new auditorium in Anderson, Ind., for the General Ministerial Assembly of the Church of God. Dome was cast at ground level, contoured over a mound of earth. It was then post-tensioned with twelve 40-wire assemblies supplied by Ryerson—and finally lifted into

place by the Youtz-Slick method. Dimensions: 250 ft. clear span, with 25-ft. cantilevers for a total span of 300 ft.; vertex of dome 68 ft. above floor level. **Architect:** Johnson, Ritchhart & Associates, Anderson. **General contractor:** Lewis Construction Co., Anderson. **Lifting:** Great Lakes Lift-Slab, Chicago; Sky Hook Lift-Slab, Overland Park, Kansas.

How Ryerson post-tensioning service makes prestressing more versatile, practical and reliable

First post-tensioned apartment building in Chicago area. Thinner slabs, more flexible arrangement of apartments and additional parking area were made possible by use of post-tensioning in the new Grove St. apartment building in Oak Park, Ill. Use of post-tensioning in this structure brought an award for the architect from the Society of American Registered Architects at their 1961 convention. **Builder:** James E. Tatooles. **Architect:** Chester A. Stark, F. A. R. A. **Structural consultant:** T. Y. Lin & Associates. **Concrete contractor:** Lundsberg Company. All are of Chicago.



There's a big difference in Neoprene Structural Gaskets

All neoprene gaskets may *look* alike—but the differences in StanLock represent exclusive and important advantages to the architect, builder, glazier and owner. Here are the reasons:

STANLOCK'S tempered locking strip

... is a separate, specially designed locking section made of harder, higher-density neoprene than the body of the gasket. While easily locked into the gasket upon installation, it applies *added pressure* at the sealing surfaces, providing a more positive seal where it is needed to prevent infiltration of water, air and dust.

STANLOCK'S time-proven neoprene compounds

... combine needed strength and relative resilience with maximum weathering properties. The right neoprene formulas, plus close control in compounding, give StanLock gaskets exceptionally long life. They meet the 25-year "actual" and the 50-year "desired" life requirements for structural seals. Hurricane wind tests have proved the resilience of StanLock to provide sufficient cushion, under severe wind loads or shock wave, to prevent glass breakage.

STANLOCK'S versatility permits freedom in design

More than 24 different StanLock gasket sections are available from existing tooling. This great variety permits a wide range of curtainwall designs—in horizontal, vertical or grid applications—using glass or panel materials, in any combination with aluminum, steel, concrete or marble. Special sections are still being designed.

THE STANLOCK^{*} LOCKING STRIP PRINCIPLE:

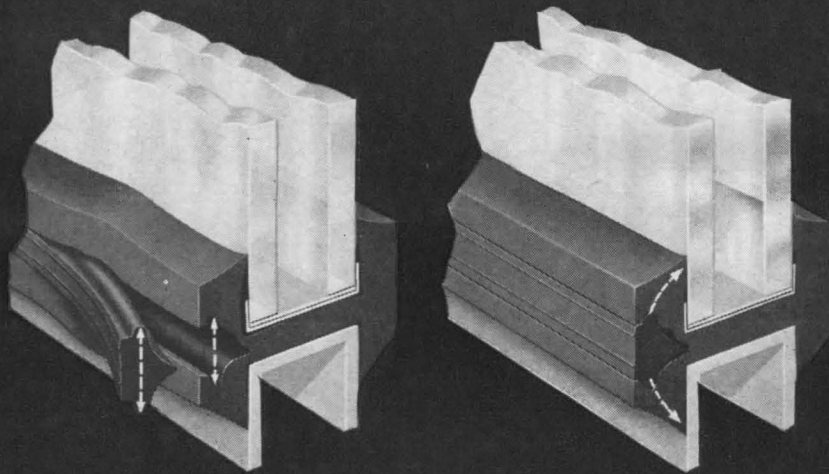

The tempered, harder, specially designed locking strip is locked into position—providing . . .

. . . more positive pressure of neoprene against glass or panel, and a long-lasting watertight seal.

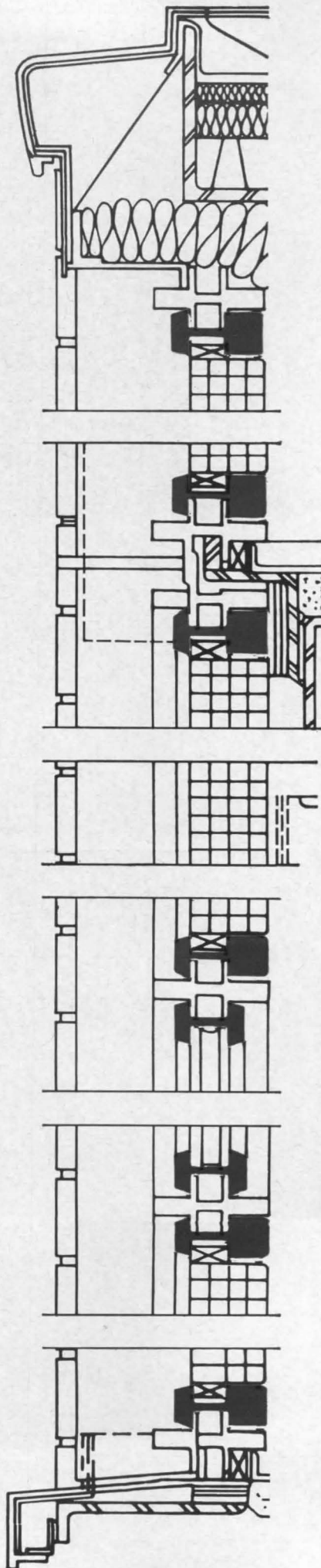

HOSPITAL BUILDING UPTREND EXPECTED TO REACH NEW PEAKS

HOSPITAL CONSTRUCTION currently is enjoying a healthy recovery after a two-year lapse. From 1958 through 1960, new building was in the doldrums with successive declines in contract valuation. This year, however, the dollar volume of hospital contracts easily will register a record high. With awards for the first nine months well ahead of last year, we estimate the 1961 total at \$980 million, about 18 per cent above 1960. Floor area represented by hospital contracts will be up sharply to about 43 million sq ft. The outlook for 1962: contracts should approximate their 1961 performance.

ON THE AVERAGE, hospital building has the highest construction cost per sq ft of any building category. This shows up clearly in the spread between dollar volume and physical volume of building. Despite the anticipated gain over 1960, floor area of hospital contracts in 1961 will not match the 1950 peak of 45 million sq ft in the 37 eastern states alone. At no time in the past decade has hospital floor area come close to that mark even after addition of the 11 western states to the Dodge statistical coverage in 1956. In the meantime, dollar volume of contracts has trended irregularly upward with new highs set in 1956, 1957, 1958, and expected again this year. Of course, the general rise in material and labor costs has affected hospital construction as much as any other building type. However, there are some special factors to consider in building hospital facilities to accommodate modern equipment and new treatment practices. Such features as special oxygen piping to individual rooms, decentralized feeding facilities, extra elevators, lead shielding for X-ray equipment, and extremely complex plumbing have helped to boost construction costs.

THE FUTURE DEMAND for hospital facilities promises to be intense. For one thing, the number of the elderly will increase substantially in the 1960's. According to the United States Public Health Service, people in the 65 and over age bracket "consume hospital services at twice the rate of younger people." Rising real incomes and wider coverage of health insurance plans will allow more families to seek the hospital treatment they need. Furthermore, although the backlog has been worked down, there is still a serious shortage of general hospital beds in some areas. In response to these factors, we anticipate a strong upward trend in hospital building during the decade.

FLOOR AREA of hospital buildings as well as dollar volume will rise to new peaks in the 1960's. According to the Modern Hospital Publishing Company, the inclusion of more complete diagnostic and related treatment facilities in new hospitals and the practice of putting fewer beds in hospital wards are largely responsible for the trend toward more floor area per bed.

EDWARD A. SPRAGUE, *Economist*
F. W. Dodge Corporation
A McGraw-Hill Company

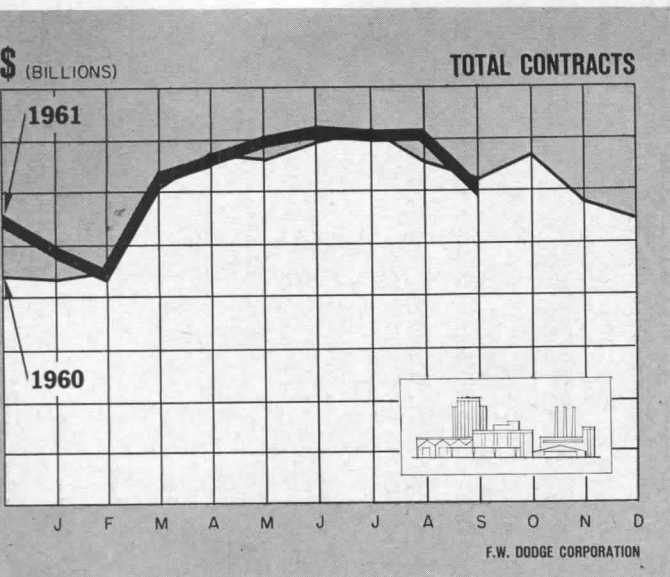

Total contracts include residential, nonresidential, heavy engineering contracts

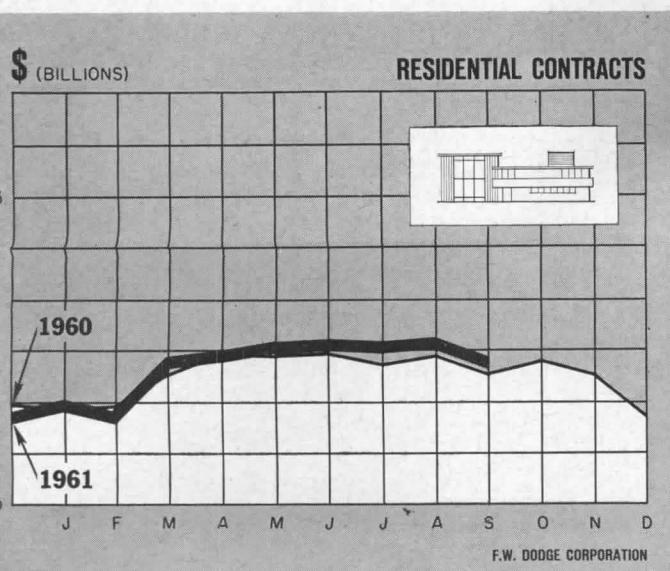
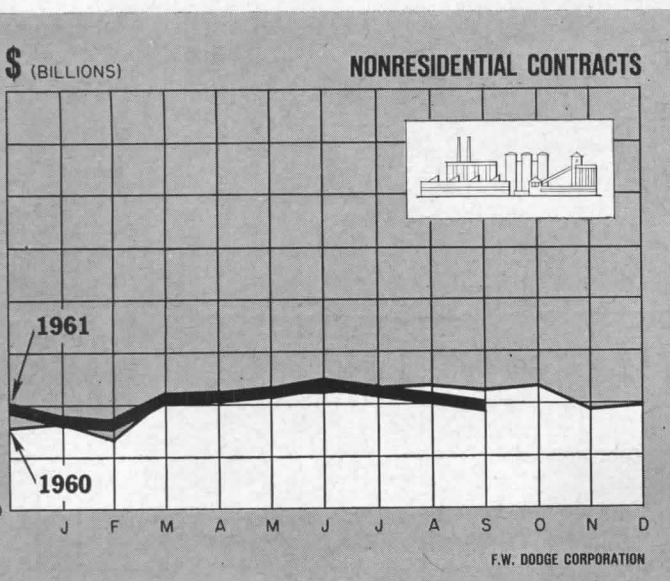

NO YELLOWING PROBLEM WITH THIS ACRYLIC

LIGHTING SHIELD

...IT'S MADE FROM DU PONT MONOCITE*

Yellowing of acrylic sheets made from MONOCITE is negligible compared with yellowing of non-acrylic plastics. In fact, the Society of the Plastics Industry specifications for the Yellowing Factor due to light exposure are ten times less stringent for non-acrylic than for acrylic plastics. A good reason for specifying acrylic shields made from Du Pont MONOCITE methacrylate monomer for the lighting fixtures in your building.



*Trademark for Du Pont's H-100 methacrylate monomer.

BETTER THINGS FOR BETTER LIVING . . . THROUGH CHEMISTRY

E. I. du Pont de Nemours & Co. (Inc.)
Dept. AR-12, Room 2507M, Nemours Bldg.
Wilmington 98, Delaware

- Please send your lighting booklet.
 Please ask an acrylic-sheet manufacturer to contact me.



NAME _____
POSITION _____
COMPANY _____
ADDRESS _____
CITY _____ STATE _____

ARCHITECTURAL RECORD December 1961 19

Meetings and Miscellany

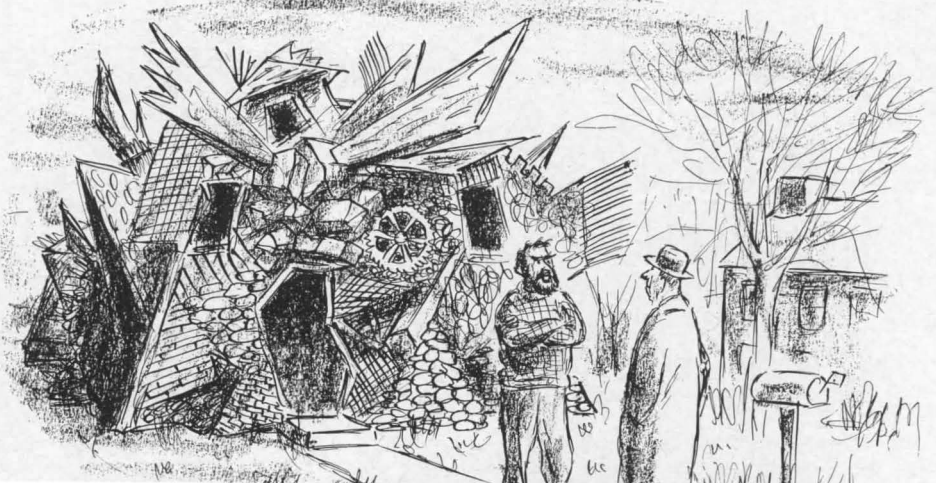

Construction Cost Indexes

Presented by Clyde Shute, Director of Statistical Policy, Construction News Div., F. W. Dodge Corp., from data compiled by E. H. Boeckh & Assoc. Inc.

Labor and Materials: U.S. average 1926-1929=100

NEW YORK

ATLANTA

| PERIOD | RESIDENTIAL | | APTS., HOTELS, OFFICE BLDGS. | COMMERCIAL AND FACTORY BLDGS. | | RESIDENTIAL | | APTS., HOTELS, OFFICE BLDGS. | COMMERCIAL AND FACTORY BLDGS. | | | |
|----------------|-------------|-------|---------------------------------|----------------------------------|-----------------------|-------------|-------|---------------------------------|----------------------------------|-----------------------|-------|-------|
| | Brick | Frame | Brick and Concrete | Brick and Concrete | Brick and Steel | Brick | Frame | Brick and Concrete | Brick and Concrete | Brick and Steel | | |
| 1930 | 127.0 | 126.7 | 124.1 | 128.0 | 123.6 | 82.1 | 80.9 | 84.5 | 86.1 | 83.6 | | |
| 1935 | 93.8 | 91.3 | 104.7 | 108.5 | 105.5 | 72.3 | 67.9 | 84.0 | 87.1 | 85.1 | | |
| 1939 | 123.5 | 122.4 | 130.7 | 133.4 | 130.1 | 86.3 | 83.1 | 95.1 | 97.4 | 94.7 | | |
| 1949 | 243.7 | 240.8 | 242.8 | 246.6 | 240.0 | 189.3 | 189.9 | 180.6 | 180.8 | 177.5 | | |
| 1950 | 256.2 | 254.5 | 249.5 | 251.5 | 248.0 | 194.3 | 196.2 | 185.4 | 183.7 | 185.0 | | |
| 1951 | 273.2 | 271.3 | 263.7 | 274.9 | 271.8 | 212.8 | 214.6 | 204.2 | 202.8 | 205.0 | | |
| 1952 | 278.2 | 274.8 | 271.9 | 265.2 | 262.2 | 218.8 | 221.0 | 212.8 | 210.1 | 214.3 | | |
| 1953 | 281.3 | 277.2 | 281.0 | 286.0 | 282.0 | 223.0 | 224.6 | 221.3 | 221.8 | 223.0 | | |
| 1954 | 285.0 | 278.2 | 293.0 | 300.6 | 295.4 | 219.6 | 219.1 | 233.5 | 225.2 | 225.4 | | |
| 1955 | 293.1 | 286.0 | 300.0 | 308.3 | 302.4 | 225.3 | 225.1 | 229.0 | 231.5 | 231.8 | | |
| 1956 | 310.8 | 302.2 | 320.1 | 328.6 | 324.5 | 237.2 | 235.7 | 241.7 | 244.4 | 246.4 | | |
| 1957 | 318.5 | 308.3 | 333.1 | 345.2 | 339.8 | 241.2 | 239.0 | 248.7 | 252.1 | 254.7 | | |
| 1958 | 328.0 | 315.1 | 348.6 | 365.4 | 357.3 | 243.9 | 239.8 | 255.7 | 261.9 | 262.0 | | |
| 1959 | 342.7 | 329.0 | 367.7 | 386.8 | 374.1 | 252.2 | 247.7 | 266.1 | 272.7 | 273.1 | | |
| 1960 | 351.6 | 337.2 | 377.7 | 395.8 | 380.6 | 259.2 | 253.3 | 274.7 | 282.5 | 278.8 | | |
| July 1961 | 367.3 | 346.6 | 405.4 | 431.3 | 403.9 | 254.8 | 247.3 | 275.0 | 284.0 | 274.5 | | |
| August 1961 | 365.9 | 344.8 | 405.1 | 431.1 | 403.5 | 254.8 | 247.3 | 275.0 | 284.0 | 274.5 | | |
| September 1961 | 366.2 | 344.9 | 405.7 | 431.7 | 404.0 | 256.0 | 249.1 | 276.4 | 284.9 | 275.2 | | |
| September 1961 | 196.5 | 181.8 | % increase over 1939 | | 210.4 | 223.6 | 210.5 | % increase over 1939 | | 190.6 | 192.5 | 190.6 |

ST. LOUIS

SAN FRANCISCO

| | | | | | | | | | | | | | | |
|----------------|-------|-------|----------------------|-------|-------|-------|-------|----------------------|-------|-------|-------|-------|-------|-------|
| 1930 | 108.9 | 108.3 | 112.4 | 115.3 | 111.3 | 90.8 | 86.8 | 100.6 | 104.9 | 100.4 | | | | |
| 1935 | 95.1 | 90.1 | 104.1 | 108.3 | 105.4 | 89.5 | 84.5 | 96.4 | 103.7 | 99.7 | | | | |
| 1939 | 110.2 | 107.0 | 118.7 | 119.8 | 119.0 | 105.6 | 99.3 | 117.4 | 121.9 | 116.5 | | | | |
| 1949 | 221.4 | 220.7 | 212.8 | 215.7 | 213.6 | 213.0 | 207.1 | 214.0 | 219.8 | 216.1 | | | | |
| 1950 | 232.8 | 230.7 | 221.9 | 225.3 | 222.8 | 227.0 | 223.1 | 222.4 | 224.5 | 222.6 | | | | |
| 1951 | 252.0 | 248.3 | 238.5 | 240.9 | 239.0 | 245.2 | 240.4 | 239.6 | 243.1 | 243.1 | | | | |
| 1952 | 259.1 | 253.2 | 249.7 | 255.0 | 249.6 | 250.2 | 245.0 | 245.6 | 248.7 | 249.6 | | | | |
| 1953 | 263.4 | 256.4 | 259.0 | 267.0 | 259.2 | 255.2 | 257.2 | 256.6 | 261.0 | 259.7 | | | | |
| 1954 | 266.6 | 260.2 | 263.7 | 273.3 | 266.2 | 257.4 | 249.2 | 264.1 | 272.5 | 267.2 | | | | |
| 1955 | 273.3 | 266.5 | 272.2 | 281.3 | 276.5 | 268.0 | 259.0 | 275.0 | 284.4 | 279.6 | | | | |
| 1956 | 288.7 | 280.3 | 287.9 | 299.2 | 293.3 | 279.0 | 270.0 | 288.9 | 298.6 | 295.8 | | | | |
| 1957 | 292.0 | 283.4 | 295.2 | 307.1 | 302.9 | 286.3 | 274.4 | 302.9 | 315.2 | 310.7 | | | | |
| 1958 | 297.0 | 278.9 | 304.9 | 318.4 | 313.8 | 289.8 | 274.9 | 311.5 | 326.7 | 320.8 | | | | |
| 1959 | 305.4 | 296.4 | 315.0 | 329.8 | 323.9 | 299.2 | 284.4 | 322.7 | 338.1 | 330.1 | | | | |
| 1960 | 311.4 | 301.0 | 322.2 | 337.2 | 329.2 | 305.5 | 288.9 | 335.3 | 352.2 | 342.3 | | | | |
| July 1961 | 317.0 | 303.8 | 330.2 | 348.2 | 332.7 | 311.8 | 293.8 | 347.4 | 364.6 | 351.2 | | | | |
| August 1961 | 316.3 | 302.9 | 330.1 | 348.1 | 332.5 | 311.6 | 293.5 | 349.0 | 365.3 | 353.4 | | | | |
| September 1961 | 316.3 | 302.9 | 330.1 | 348.1 | 332.5 | 311.6 | 293.5 | 349.0 | 365.3 | 353.4 | | | | |
| September 1961 | 187.0 | 183.1 | % increase over 1939 | | 178.1 | 190.6 | 179.4 | % increase over 1939 | | 195.1 | 195.6 | 197.3 | 199.7 | 203.3 |

Cost comparisons, as percentage differences, for any particular type of construction, are possible between localities, or periods of time within the same city, by dividing the difference between the two index numbers by one of them; i.e.:

index for city A = 110
index for city B = 95

(both indexes must be for the same type of construction).

Then: costs in A are approximately 16 per cent higher than in B.

$$\frac{110-95}{95} = 0.158$$

Conversely: costs in B are approximately 14 per cent lower than in A.

$$\frac{110-95}{110} = 0.136$$

Cost comparisons cannot be made between different types of construction because the index numbers for each type relate to a different U. S. average for 1926-29.

Material prices and wage rates used in the current indexes make no allowance for payments in excess of published list prices, thus indexes reflect minimum costs and not necessarily actual costs.

The key to
school air conditioning
is in your hands...

Changing educational patterns
demand flexible schools
with learning spaces equipped
for year-round air conditioning
under unitary control—
as an economic necessity based
upon educational productivity
for the life of the building.



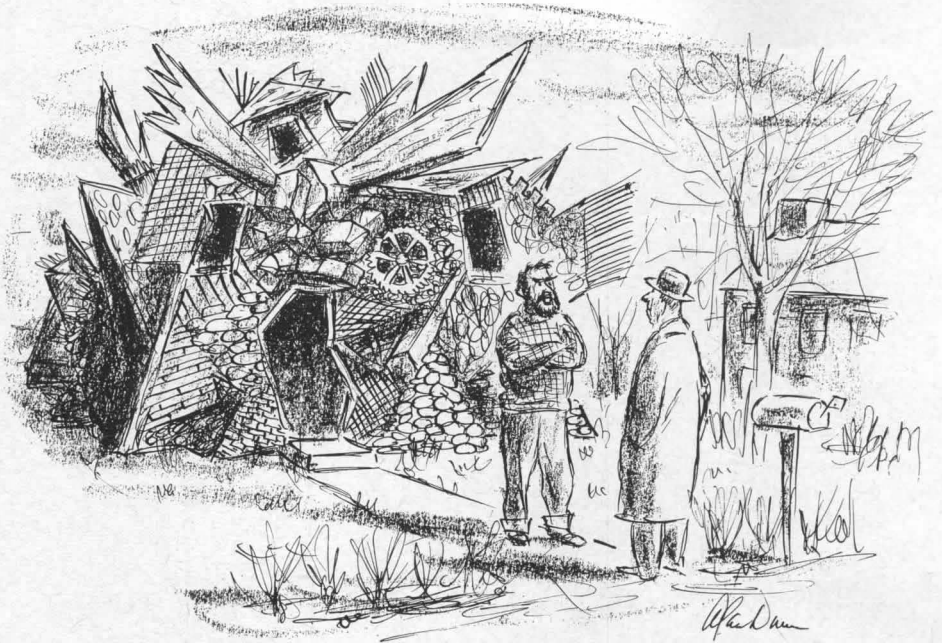

—Drawn for the RECORD by Alan Dunn

“Michelangelo was a sculptor turned architect and I am a sculptor—ergo!”

New Chief Economist Named By F. W. Dodge Corporation

Dr. Gordon W. McKinley has been appointed a vice president and chief economist of F. W. Dodge Corporation, publishers of ARCHITECTURAL RECORD among many services and publications in the construction field.

Dr. McKinley, who will also act as economics consultant to the RECORD, has previously been executive director of economic and investment research for Prudential Insurance Company of America. Before joining Prudential in 1951, he taught economics first at Lehigh University and later at Ohio State.

A 1938 graduate of McMaster University, Hamilton, Ont., with a B.A. degree, Dr. McKinley received his master's and doctoral degrees from Ohio State University. He is the author of numerous articles in professional journals and co-author of the book *The Federal Reserve System*.

Architectural League Holds Gold Medal Competition

Open submissions are invited for the 1962 National Gold Medal Exhibition of the Architectural League of New York, to be held next April 6 through 27 in the League building, 115 E. 40th Street, New York.

Both open submissions, which

must be received at the League by January 2, and a group of invited submissions will be eligible for the League's Collaborative Medal of Honor and for Gold and Silver Medals and Honorable Mentions in the fields of architecture, landscape architecture, engineering, mural decoration, sculpture and design and crafts. Submission is open to any practitioner who is a citizen of the U.S., whether or not he is a member of the League; work submitted must have been completed between Jan. 1, 1959 and Dec. 31, 1961 and, in the allied arts, *must* have a relationship to architecture.

Complete details and entry blanks may be obtained upon request to the League.

Dunn Appointed Head of A.G.C.

William E. Dunn has been appointed executive director of the Associated General Contractors of America, to succeed the late James D. Marshall.

Mr. Marshall died on November 3rd from complications following an operation. He had been connected with the A.G.C. since 1925, having become assistant managing director in 1940, executive director in 1953, and in 1956 chief executive in the management of the association.

In announcing the appointment of Mr. Dunn, M. Clare Miller,

A.G.C. president, said: “Mr. Dunn has been affiliated with the A.G.C. national staff for 14 years, and has been assistant executive director for nearly six years. During this time he has been closely associated with Mr. Marshall in the administration of A.G.C. policies and operations.”

Morgan Receives Building Stone Institute Award

The Building Stone Institute Annual Architect Award for distinguished use of natural stone was presented this fall to Lloyd Morgan, F.A.I.A.



(Left to right) Lloyd Morgan and Gen. C. J. Hauck, chairman of Building Stone Institute Awards Committee

He was cited for “inspiring contributions in the field of architecture . . . imaginative creativity in utilizing natural stone in distinguished buildings of enduring beauty throughout the world.”

continued on page 30

The key to
school air conditioning
is in your hands...

Changing educational patterns
demand flexible schools
with learning spaces equipped
for year-round air conditioning
under unitary control—
as an economic necessity based
upon educational productivity
for the life of the building.

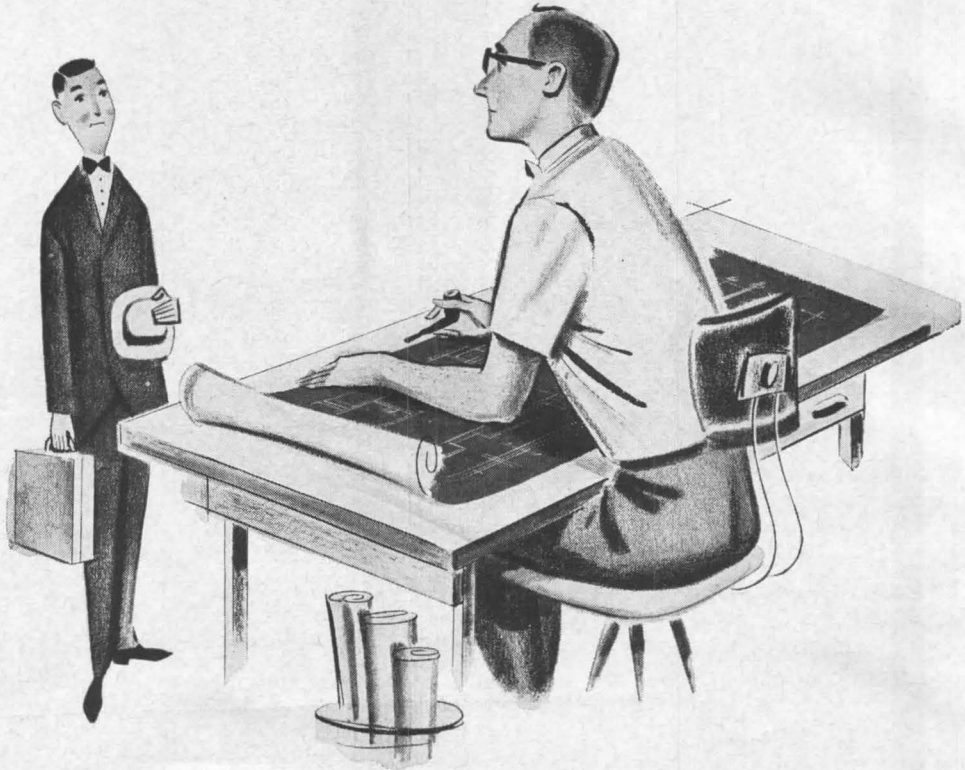

New schools need air conditioning.

To produce the quality and quantity of education required in the future, school buildings must be free of the excess heat that shackles learning in many of the nation's classrooms from early spring to late fall. School people know this; but some of them are inhibited by public opinion or by the notion that an air-conditioned school must be an inartistic box. It is largely up to you to correct these impressions . . . by explaining how air conditioning eliminates the greatest physical threat to learning, and by showing how it frees school architecture from old clichés and permits you to meet the educational specifications with originality and economy. As you know, a renaissance in school design is already under way, stimulated by the need for controlled environment schools—and Nesbitt *Year-Round Unit Ventilators* are being widely employed as the preferred equipment for all-season thermal comfort in every learning space. Nesbitt can help you to explain the importance of school air conditioning with slide films, case studies, cost data, publications, and other services.

MORE LEARNING PER SCHOOL DOLLAR

Nesbitt AIR CONDITIONING FOR SCHOOLS



Year-Round Unit Ventilator and Storage Cabinets • Made and sold by John J. Nesbitt, Inc., Philadelphia 36, Pa.



NEW NEW NEW NEW NEW NEW NEW

SINKO **PARAHEX*** LOUVERS' New Parabolic Construction

*provides
higher levels
of illumination
with excellent*

**VISUAL
COMFORT**

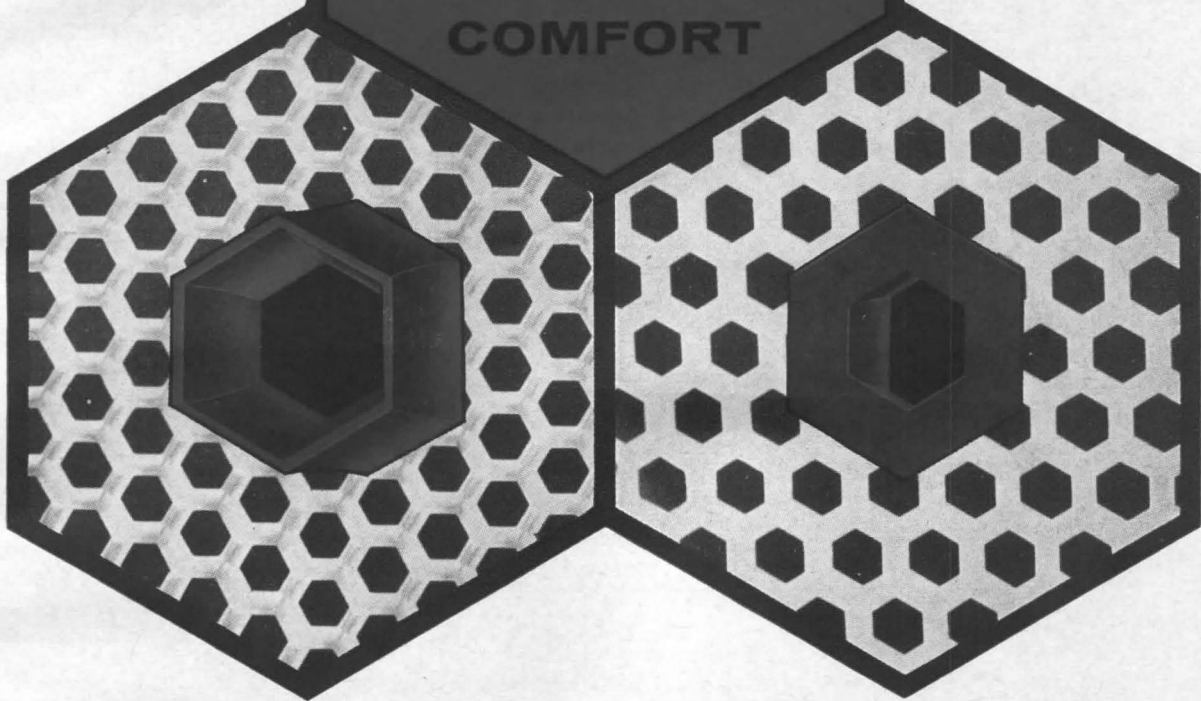

Bottom View of PARAHEX Louver

Top View of PARAHEX Louver

When the PARAHEX Louver is used in its metalized finish and is installed in fixtures and/or luminous ceilings, it controls the lamp brightness so well that it is sometimes difficult to distinguish whether or not the lamps are actually lighted — yet the PARAHEX Louver may be providing a maximum of illumination levels.

The new PARAHEX Louver offers new applications in lighting design and adds new functional beauty to lighting installations.

Not only is the PARAHEX a new advancement in lighting

comfort, but it is also an outstanding achievement in the field of plastic molding. In the PARAHEX, Sinko has again proven its ability to meet the challenge of molding the unusual.

PARAHEX Louvers are available in one piece, nominal 2 ft. by 4 ft. panels, in either translucent white Polystyrene, specular and satin aluminum vacuum plated metalized finishes, and in Acrylic, either translucent white or crystal clear. PARAHEX cell dimensions are 1/2" high x 3/8" x 9/16" with 45° x 45° shielding.

We invite you to write today for design samples and engineering data sheets.



SINKO MANUFACTURING & TOOL CO.
7310 W. Wilson Avenue • Chicago 31, Illinois

In Canada:

Sinko Manufacturing & Tool Co. of Canada, Ltd. 3550 Frobisher Street, Montreal, Quebec

*Manufactured under License from General Electric Company Pat. No. 2971083

Meetings and Miscellany

continued from page 27

New Postgrad, Undergrad Programs at Columbia

In recognition of the increasing demand for specialized architectural study, Columbia University's School of Architecture has instituted two new postgraduate programs. The new programs, both leading to the degree of Master of Science in Architecture, provide the opportunity for architects to gain intensive specialized training in the design of medical or educational facilities.

Dean Charles R. Colbert said, "Columbia's School of Architecture is, to the best of my knowledge, the only architectural school in the United States offering degrees in 'specialties'—that is, degrees in building-types or problem areas. We . . . believe that this is a highly significant innovation in architectural education. What it means in essence is that the design of medical and educational facilities will at last be entrusted to architects and planners specially equipped to handle the numerous problems inherent in the design of these complex buildings."

The program in medical facilities planning will be conducted by the School of Architecture in conjunction with the School of Public Health, the educational facilities program, with Teachers College.

"The new programs," Dean Col-

bert explained, "are based on the assumption that mere technical competence is not sufficient for the design of buildings so vital to the community welfare. To design an effective educational or medical plant necessitates an understanding of the disciplines of education and medicine themselves . . . Students come to us imbued with the viewpoint of the architect; we intend to expose them to the viewpoints of the educator and the hospital administrator."

In addition to the postgraduate programs, Columbia's School of Architecture will offer for the first time the degree of Bachelor of Planning, as well as the traditional degree of Bachelor of Architecture. Moreover, to insure that future architects and planners will be able to work effectively with each other, all undergraduate students at the School, irrespective of their intended fields of specialization, will be required to take a core curriculum of courses in both architectural and planning design.

According to Dean Colbert, "Essentially our revamped curriculum has two aims. The first is to provide community planners with comprehensive professional training. The second is to provide a basis of communication between architects and planners, diminishing the schism that has grown up between them and, hopefully, producing more intelligent

building programs.

"The new emphasis," Dean Colbert said, "is on the city—which is, after all, the central problem confronting both architects and planners today. The sad plight of today's metropolises, the haphazard fashion in which urban centers have been allowed to grow, might well have been avoided had there been more communication between architects and community planners. Future projects for urban rehabilitation—which many large cities have already embarked upon—will be similarly ill-fated if this communication-gap is allowed to continue. We at Columbia hope to do our part in insuring that history does not repeat itself. It is a task upon which the very future of urban society depends."

Hellmuth Elected Fellow in International Institute

George F. Hellmuth, Hellmuth, Obata & Kassabaum, St. Louis, has accepted election to life membership as a Fellow in the International Institute of Arts and Letters, Kreuzlingen, Switzerland. The Institute's world-wide membership consists of 1760 Fellows and Corresponding Members "qualified by notable achievements in Arts, Letters or in Sciences and other fields of culture."

SAARINEN MEMORIAL SERVICE HELD IN M.I.T. CHAPEL

A memorial service for Eero Saarinen was held on September 9 in the renowned circular chapel he designed for the Massachusetts Institute of Technology. The service was conducted by his—and his father Eliel's—longtime friend and client, J. Irwin Miller of Columbus, Ind., and it went as follows:

Let us remember the life of a good man. Hear the words of the Psalmist:

Blessed is the man who walks not in the counsel of the wicked
Nor stands in the way of the sinner,
Nor sits in the seat of scoffers.
But his delight is in the law of the Lord
And on His law he meditates day and night.
He is like a tree planted by streams

of water
That yields its fruit in its season,
And its leaf does not wither.
In all that he does, he prospers.

Let us remember the life of a man who loved and was loved. Hear the words of Elizabeth Browning:

Go from me. Yet I feel that I shall stand
Henceforward in thy shadow. Nevermore
Alone upon the threshold of my door
Of individual life, I shall command
The uses of my soul, nor lift my hand
Serenely in the sunshine as before,
Without the sense of that which I forebore,—
Thy touch upon the palm. The widest land
Doom takes to part us, leaves the heart in mine

With pulses that beat double. What I do
And what I dream include thee, as the wine
Must taste of its own grapes. And when I sue
God for myself, He hears that name of thine,
And sees within my eyes the tears of two.

Let us remember the life of a great man, who wrought more than most. Hear the words of Pericles:

To famous men all the earth is a sepulchre, and their virtues shall be testified, not only by the inscription in stone at home, but by an unwritten record of the mind, which more than of any monument will remain with everyone forever.

continued on page 232

CLIMATE BY CHRYSLER

680 TONS

Ross Gear and Tool Co., Lebanon, Tenn. Architects and Engineers: Spencer J. Warwick & Associates. General Contractor: Anderson and Gore. Mechanical Contractor: Central Air Conditioning & Heating, Inc.

680 tons of Chrysler Air Conditioning on the roof save 1100 sq. ft. of valuable floor space inside

Sprouting from the roof of this new plant for Ross Gear and Tool Company are 22 Chrysler 30-ton packaged air conditioning units. Together with two Chrysler packaged liquid chillers and four split-system units, they provide the cooling (785 tons of it!) for almost five acres of manufacturing and office space.

By putting 680 tons of Chrysler Air Conditioning on the roof, instead of under it, the company freed 1100 sq. ft. of valuable floor space for other jobs. And by installing these units zone-by-zone during construction, the company saved money by starting operations in part of the building while the rest was being completed.

The cooling load is spread over 28 different Chrysler units, ranging from a 4-ton condensing unit to a 45-ton chiller. Thus, varying departmental load requirements can be handled with ease. There

is no fixed operating cost, as there would be with a conventional single-unit installation.

Whether your job calls for air-cooled or water-cooled equipment . . . packaged units or chillers . . . you'll find the complete Chrysler line has the exact unit you need. For complete data, or the technical cooperation of a Chrysler Engineer, write today.



CHRYSLER
AIR TEMP

A Division of Chrysler Corporation
Dept. S-121, Dayton 4, Ohio

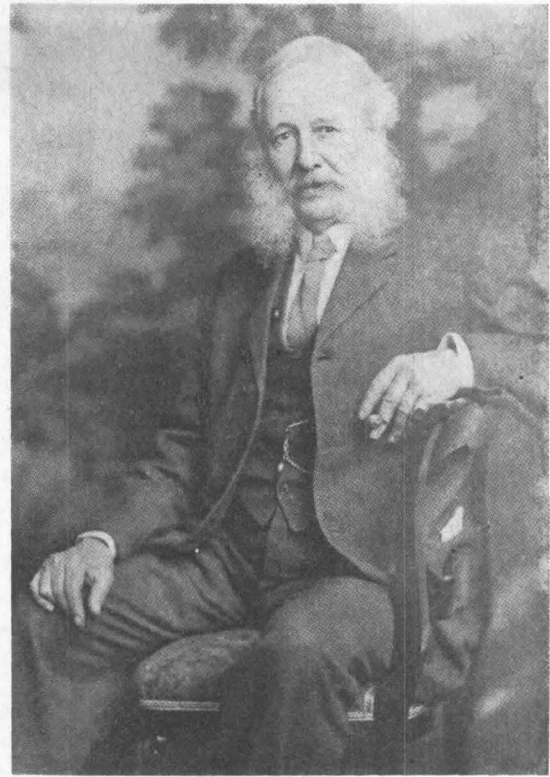

Montgomery Schuyler
—from *American Architecture and Other Writings*

Schuyler Collected

AMERICAN ARCHITECTURE AND OTHER WRITINGS. By Montgomery Schuyler; edited by William H. Jordy and Ralph Coe. The Harvard University Press, Cambridge 38, Mass. 664 pp., illus. 2 vols., \$12.50 the set.

Starting with, as a base, Schuyler's 1892 volume *American Architecture*, the editors have added many articles which appeared in both architectural and general periodicals. Since Schuyler is so often quoted, and since access to his writings has till now meant a search for books and magazines 50 and 60 years old, this collection is welcome both as general reference and general reading.

Schuyler, the editors remark in their lengthy introduction, has long been required to bear a burden of perspicacity which he is not fully equipped to support, and which, it might be added, it is unfair to demand. He was, they go on, no more infallible than his times permitted. His ideas had been formulated by a study of Ruskin, Violet-le-Duc and an obscure but highly interesting Bohemian-American architect, Leopold Eidlitz. This study led to his acceptance of 19th century architectural standards which the editors enumerate as individualism, tangibility and

articulation—valid standards in discussing the Gothic revival, but not particularly germane to the problems of the skeleton-frame skyscraper. The editors contend that Schuyler's adherence to these basics made him fail to appreciate the esthetic possibilities of the new structures. In truth, he did often seem puzzled that buildings which so satisfactorily fulfilled his rational requirements should disappoint his eyes; he once compared his reaction to a Sullivan skyscraper as that of the "East Indian to his idol: we know that he is ugly but we feel that he is great."

Still, he struggled against his undoubted prejudices, and if he did not see the worth of the new architecture, he *knew* it, and said so often and feelingly and in print (voluminously in ARCHITECTURAL RECORD, often in magazines like *Harper's* and *Scribner's*). And if he occasionally seems wistful that architecture did not develop as he imagined it might as a young man, neither does he seem, as one reads him, to regret it much.

In addition to some of his articles on skyscrapers, the editors have included Schuyler on Victorian Gothic, on the "Richardsonian interlude," on the Beaux Arts, on Sullivan and Wright, and on bridges—this last group giving insight into Schuyler's

interested in pure engineering, but quite possibly included for its sheer charm.

As for the pertinence of Schuyler's opinions, they would seem to have little today, as he discusses an architectural fight which was long and bitter, and is now quite over. In their introduction, the editors suggest that his views may not lack pertinence: "Since World War II, modern architecture has come back to the ideals of individuality, tangibility and articulation, and to a renewed interest in history, which reintroduces the dilemmas of creative eclecticism as well. Today Schuyler's criticism assumes new relevance. . . . And so does its underlying premise: 'It is more feasible to tame exuberances than to create a soul under the ribs of death.' Could it be that the critic for a lost cause will become the prophet for a new one?"

There is another reason for an edition of Schuyler's writing—it makes wonderful reading. The prolixities and allusions of his old-fashioned style are not difficult and are anything but boring. And he exhibits what has been called the "biliousness" of good criticism, informing his words with considerable force and conviction even at this distance in time.

more books on page 48



La Salle Street looking south from Chicago River

CHICAGO DISCOVERS that traffic congestion either ends at curbside or extends into building lobbies—depending upon the kind of elevating used. Why? Because there is more to completely automatic elevating than simply leaving the operator out of the car! Any elevator installation that fails to provide complete automation for all of the constantly changing, widely varying traffic patterns that occur throughout the day and night—invites curtailed service, long waits and traffic congestion. This applies in a like degree to the greatest skyscraper and the smallest commercial or institutional building. How do tenants and visitors react? After all, they are people. They react in a like manner to elevator service. And a building's reputation soon reflects their reactions. The mark of a CLASS "A" building—large or small—is completely automatic AUTOTRONIC® elevating. It accurately predicts and delivers a magnificent performance. Since 1950, more than 1,100 new and modernized buildings across the United States and Canada have contracted for AUTOTRONIC elevating by OTIS—the world's finest!



**OTIS
ELEVATOR
COMPANY**

260 11th Avenue, New York 1, N. Y.
Offices in 448 cities around the world

AUTOTRONIC® OR ATTENDANT-OPERATED PASSENGER ELEVATORS • ESCALATORS • TRAV-O-LATORS • FREIGHT ELEVATORS • DUMBWAITERS
ELEVATOR MODERNIZATION & MAINTENANCE • MILITARY ELECTRONIC SYSTEMS • GAS & ELECTRIC TRUCKS BY BAKER INDUSTRIAL TRUCK DIVISION



HAWS Model 7X

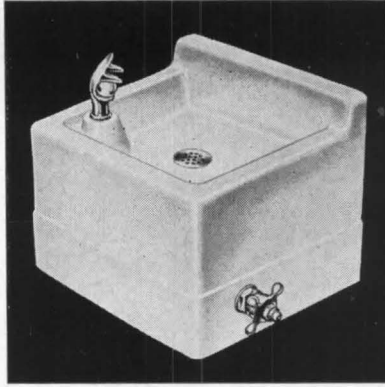

RUGGED

Look at the *back* of this rugged HAWS fountain! The sturdy cast iron body is gripped in a thick shell of smooth porcelain enamel—impervious to weather extremes, corrosion, *even acids!* That's why HAWS Model 7X is the ideal specification for outdoor areas, industrial and chemical plants throughout the world! And good looking, too! This popular model matches anything on the market for sheer streamlined beauty. Get ruggedness with style. Specify HAWS!

WRITE FOR DETAILED SPECS

or request your free copy of the comprehensive Haws catalog. Also refer to your Sweet's File.

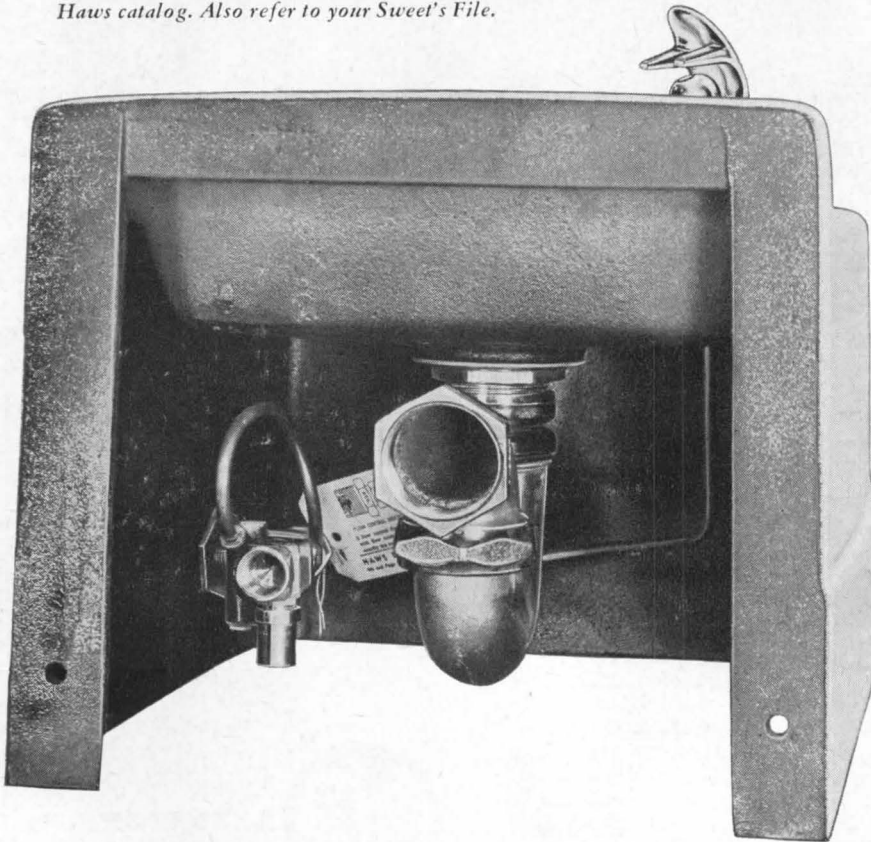

Since 1909



DRINKING FOUNTAINS

products of
HAWS DRINKING FAUCET COMPANY

1441 Fourth Street, Berkeley 10, California

Export Dept.: 19 Columbus Ave., San Francisco 11, California

Required Reading

continued from page 42

A Sculptor's Architecture

THE ARCHITECTURE OF MICHELANGELO. *By James S. Ackerman. The Viking Press, Inc., 625 Madison Ave., New York 22. Vol. I, 156 pp., illus.; Vol. II, 155 pp. (catalog). \$12.50 each.*

Michelangelo appears to be very much with us these days. Not that he hasn't always been, certainly, but in recent months we have seen books on his painting, on his sculpture, on his theories and on his life. What this impressive resurgence of research signifies the reviewer cannot guess, but it is producing good fruit—in this case, an excellent *history* of Michelangelo's architecture.

Mr. Ackerman discusses the "why" of Michelangelo's architecture in an introduction covering his theories, as far as these can be determined. Very little evidence exists of these: only, in fact, a fragment of a letter written by him, and what can be deduced from the reactions of his contemporaries. His approach, as interpreted here, was organic—not the rather botanical organic approach of the 19th century, nor the Renaissance "humanist" approach of divine proportions. It depended on an ultimately abstract theory of human anatomy and, particularly, movement.

The "how" of his buildings is treated in individual chapters on each of them. Michelangelo's buildings were never finished until the last stone was in place. They started with dynamic drawings taking next to no consideration of structure, and proceeded through many steps of readjustment to structural versus visual facts until completion. It is quite a feat, under these circumstances, to reconstruct the progress of any of them. Mr. Ackerman has accomplished it.

He has, indeed, accomplished it twice. Once for the general reader, in Volume I, and again for the serious scholar, in Volume II—a catalog of the buildings described by original and secondary sources. The volumes are sold separately.

continued on page 52

... Only

LENNOX[®]

**Comfort Curtain[®]
provides full room
air distribution**

WITH...

*Individual room control of
fresh air ventilating and heating
... for only \$1.07 per sq. ft.*



Wellerwood Elementary School
Grand Rapids, Michigan
Colton-Hornbach Associates, Architect

Since COMFORT CURTAIN equipment is independently controlled, each room's temperature level can be immediately altered to meet the requirements established by the number of students, their activity, and outside weather conditions. The total heating and ventilating cost for ten classrooms was \$1.07 per sq. ft. The COMFORT CURTAIN equipment included: all controls; gas-fired heat sources (in approved heater rooms between every two classrooms); air processing units in each room which control, blend and filter precise amounts of fresh outdoor air, heated air and return air, and distribute it uniformly along the full length of the exterior wall. The air is discharged through functional pre-finished bookshelf ducts. No central heat plant, furnace room, and elaborate duct or piping systems were required. Simple structural requirements and ease of installation reduced initial costs and over-all expenditures.

The Record Reports

Four Bridges Win A.I.S.C. Competition

In a competition which has been sponsored for 32 years by the American Institute of Steel Construction, four steel bridges in four different categories have been designated the most beautiful opened to traffic in the United States during 1960.

The top prize winners and four honorable mentions were chosen from 89 entries located in 29 states by a distinguished jury. The jury included: A. L. Aydelott, A.I.A., A. L. Aydelott and Associates, Memphis; Thomas S. Buechner, Director, Brooklyn Museum, Brooklyn, N.Y.; Professor Glenn W. Holcomb, President, American Society of Civil Engineers, Oregon State University, Corvallis, Ore.; George Lindstrom, Lundstrom & Skubic Architects, Chicago; and Geoffrey Platt, F.A.I.A., New York.

Special ceremonies will be held at a later date in which stainless steel plaques will be affixed to the four prize bridges and certificates awarded the designers, owners and structural steel fabricators of the honorable mentions.

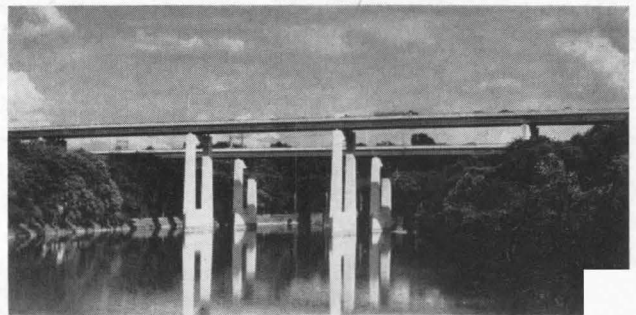

Winner of the Class I Award, for bridges with spans 400 ft or more, was Summit Bridge, over the C & D Canal, Summit, Del. The owner, U.S. Army Corps of Engineers; designer: J. E. Greiner; fabricator: American Bridge Division, United States Steel Corporation. The jury praised the long, low silhouette, graceful arch of the through-truss design that blends with the gently rolling countryside.

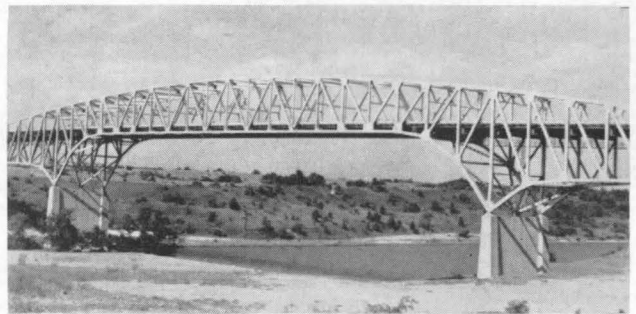

The Class II Award, for bridges with fixed spans under 400 ft and costing more than \$500,000, was won by Roosevelt Boulevard Bridges, over the Schuylkill River, Philadelphia. The owner: Pennsylvania Department of Highways; designer: Richardson, Gordon & Associates; fabricator: Bethlehem Steel Company. The jury noted "the excellent balance between steel girders and concrete piers creating an honest design that embodies classic lines, stately proportions."

continued on page 88

on the
one hand
economy

and on the other
beautiful
durable floors



Let the Hillyard "Maintainer" ...an experienced floor specialist...
prove to you that the best floor treatments not only give your floors
the deepest, most durable beauty—but also prove most economical
for your client to maintain.

On TERRAZZO • WOOD • CONCRETE • ASPHALT
VINYL • RUBBER or GYMNASIUM

YOU'LL FINISH AHEAD WITH

HILLYARD

ST. JOSEPH, MO.

PASSAIC, N. J.
SAN JOSE, CALIF.



Write for Hillyard A.I.A. Files...
contain draft specifications and treating instructions
for each type of flooring.

Proprietary Chemists Since 1907

BRANCHES AND WAREHOUSES IN PRINCIPAL CITIES



FLOORING, J-M TERRAFLEX

Brings a true 3rd dimension to sound control!

Acoustic material is a woven fiber glass fabric. These are folded into units 24" x 24" x 2" high, which are of a shell-like thickness about one-third that of flat sound-control panels. Yet they are strong, rigid and easily installed in a simple suspended grid system.

Standard Acousti-Shell fabric colors are white, blue and green. On special order, however, the surface fabric may be dyed in a wide variety of colors or can be printed with custom designs.

The new Acousti-Shell line also includes flat panels for

borders, for areas around columns and beams, for spotlight cut-outs and similar uses.

For more information and a look at this unique new ceiling panel, call your J-M Representative. Or write Johns-Manville, Dept. AR-12, Box 158, New York 16, N. Y. In Canada: Port Credit, Ont. Cable: Johnmanvil.

JOHNS-MANVILLE 

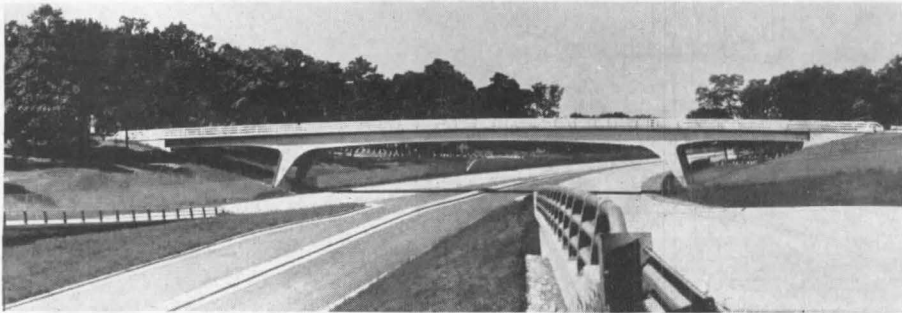

The Class III Award, for bridges with spans under 400 ft, costing under \$500,000, went to Cemetary Access Bridge, Milwaukee, Wis. The owner:

Milwaukee County Expressway Commission; designer: Howard, Needles, Tammen & Bergendoff; fabricator: C. Hennecke Company. The jury commented, "the most impressive entry in the competition. The imaginative integration of the tapered leg and curving girder into one continuous rigid-frame is at once graceful and exciting."

NOW



every building
can have
automatic doors

...with **HORTON**
AUTOMATIC SLIDING DOORS

...for stores, restaurants, hospitals, hotels,
banks, offices, drive-ins, malls, lounges,
residences, other commercial uses.

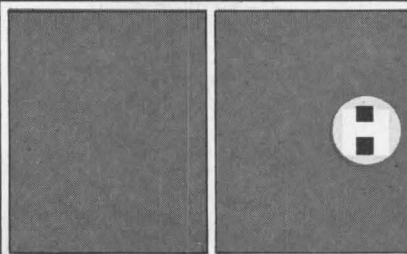



**One-third the cost
of conventional
automatic doors**

Horton Automatic Sliding Doors improve design, enhance the beauty, and increase the value of property — and since Horton Automatic Operators are 1/3 the cost of most automatic doors, even low budget buildings can have automatic doors.



**Sleek,
hideaway
design**

Horton Automatic Sliding Doors make automatic doors compatible to every architectural style — and they improve the appearance of almost every building.



HORTON
automatics, inc.

121 Gibson Ln., Corpus Christi, Texas

Please tell me more about your automatic operator for sliding door. Also send price information.

NAME _____

ADDRESS _____

CITY _____ STATE _____



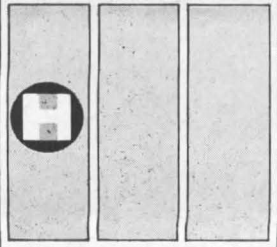

**No maintenance
required**

Recently, Horton Automatics, Inc., to fully test its product, operated a door one million times — then sold it (the automatic operator) with a new operator warranty. This automatic operator has called for no maintenance to date — proof of its practicability and economy.

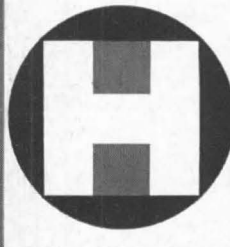

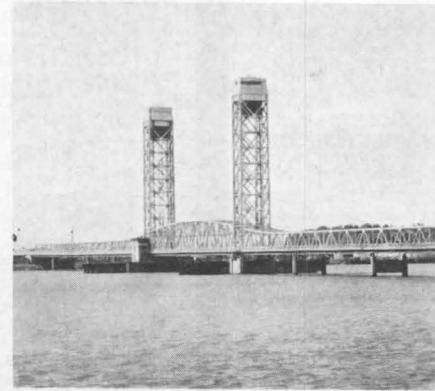

The Class IV Award, for movable bridges, was granted Rio Vista Bridge, over the Sacramento River at Rio Vista, Calif. The owner: State of California; fabricator: Judson Pacific-Murphy Corp. Division, Yuba Consolidated Industries, Inc. The jury cited this bridge for its straightforward design. In contrast with most lift bridges, these two towers are "decorative as well as functional, providing stark contrast with the horizontal line established by the approaches."

Honorable mention awards were given Bonner Springs Bridge, Bonner Springs, Kan.; Mansfield Reservoir Bridge, Hollandsburg, Ind.; North Fork Conumnes River Bridge, Placerville, Calif.; and Grand River Bridge, Harpersfield, Ohio.

Mr. M. G. Gaskin, chairman of the board of Taylor & Gaskin, Inc., Detroit, and chairman of the A.I.S.C. Committee on Awards, said, "The number of entries received indicates an increasing interest on the part of state highway departments and bridge engineers in the use of structural steel for its strength, lightness, durability and esthetic possibilities. The jury particularly commended those bridge designs which did not intrude on their natural settings but were handled with restraint and sensitivity."

more news on page 198



All photos © Ezra Stoller Associates, except as noted

SPACE-FRAMED ADMINISTRATIVE CENTER

*SOM's skillful blend of structural expression,
changing scale, notable landscaping, and fine detail
results in distinguished architecture for the Upjohn Company*



The building serves solely as the administrative nerve center for an industrial and distribution complex composed of buildings located both here and abroad

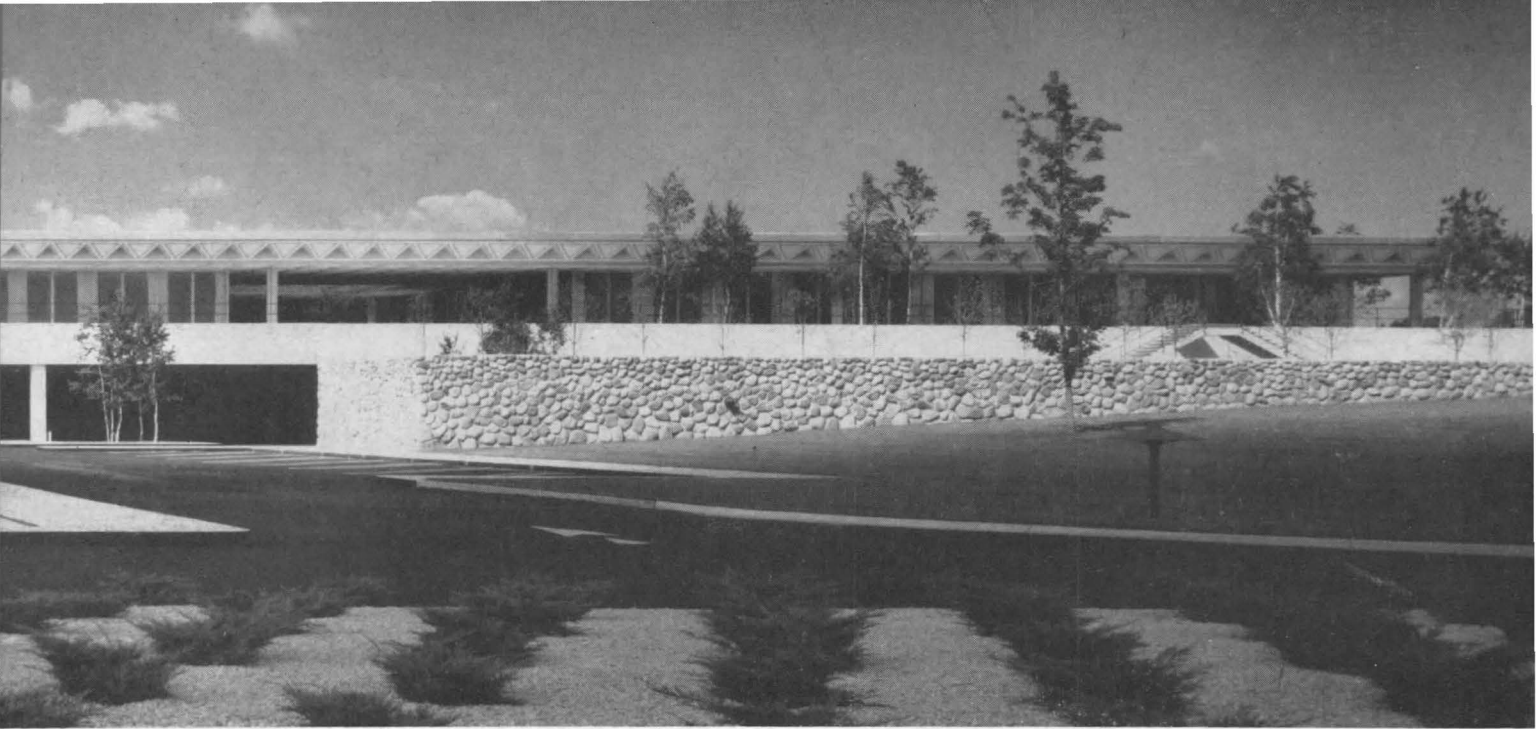

General Office Building, The Upjohn Company, Kalamazoo, Michigan

This handsome new general office building for The Upjohn Company is notably appropriate for both its setting and purpose; makes use of an unusual space frame to carry out those objectives in distinguished fashion.

The building is in the form of a spreading pavilion surmounting a lower level structure—or base plinth—devoted principally to services. This parti followed a study of various alternate ideas, including high-rise structures. The pavilion's long, horizontal line fits easily into place in the softly rolling Michigan prairie; and has its plinth tied to the 80-acre site by native stone retaining walls. A series of pools in courtyards and at base level—as well as three new man-made ponds—serve to echo the lakes that characteristically dot the region.

The idea of an informal relationship between departments and a free flow of spaces led to the pavilion concept, and the idea of diminishing scale and detail from prairie to courtyard.

William E. Hartmann, Bruce G. Graham, and William E. Dunlap were the SOM principals, supported by the mechanical, structural, and architectural departments.

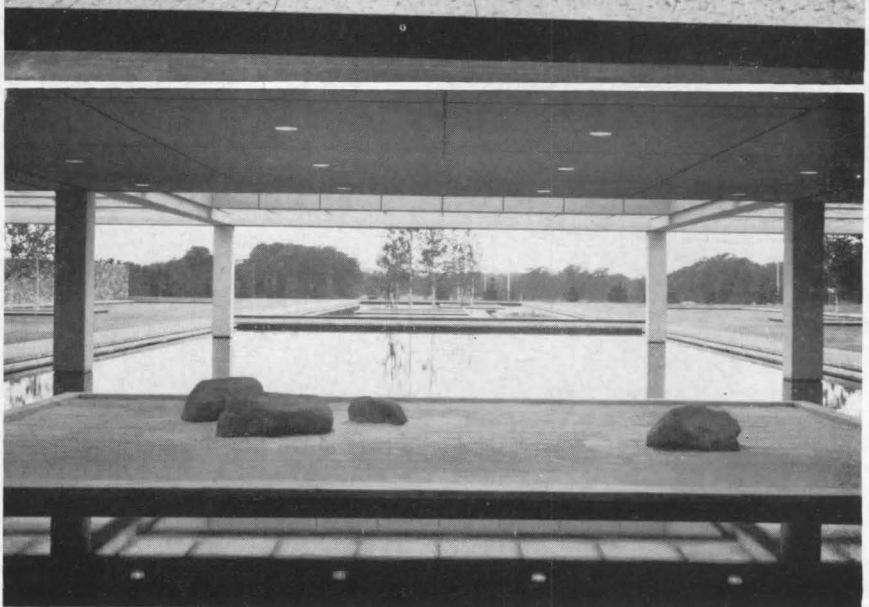

Two photos above show how water is used effectively to tie building and parking area (top) and motor entrance (bottom) to the surrounding countryside

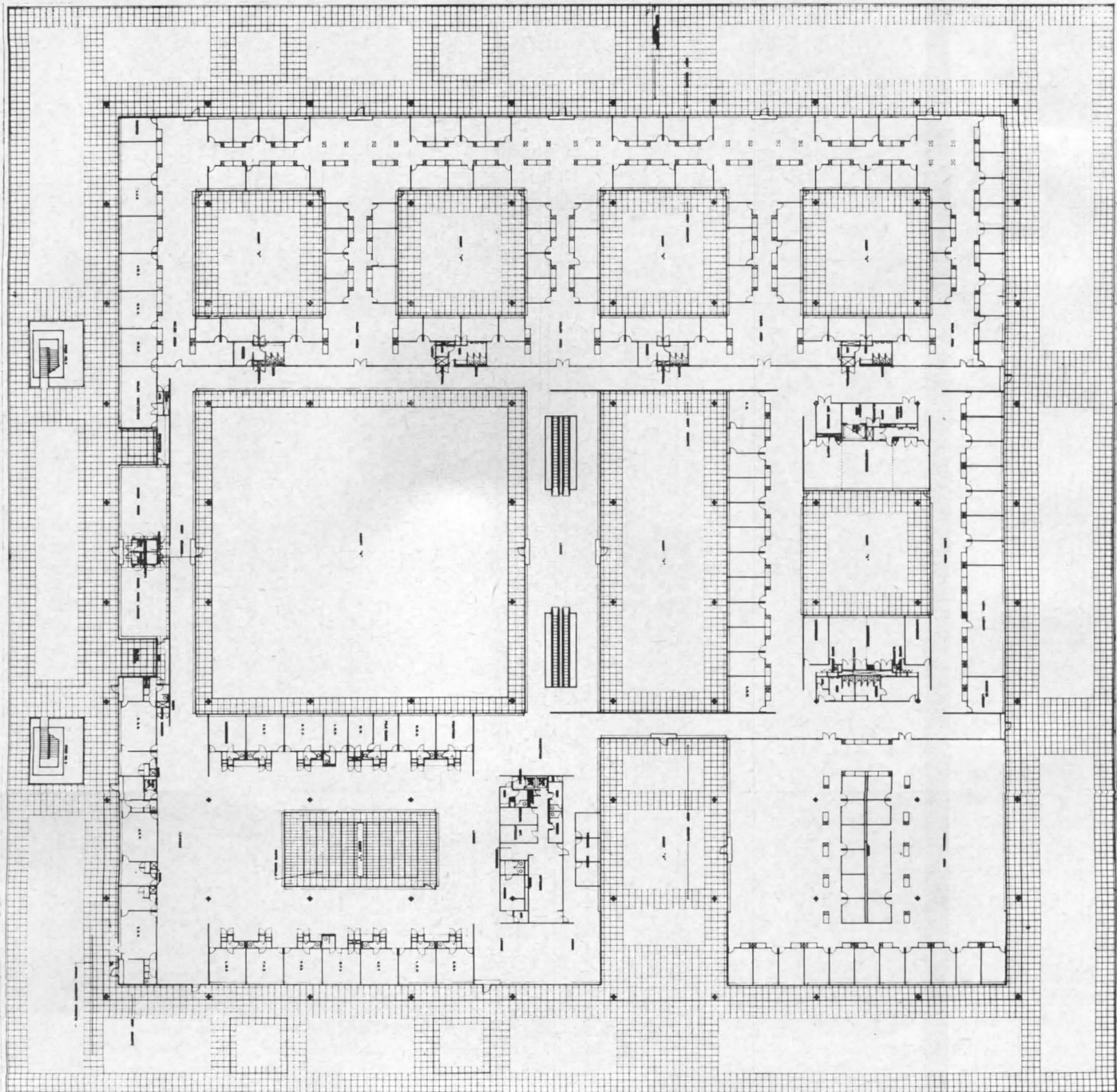
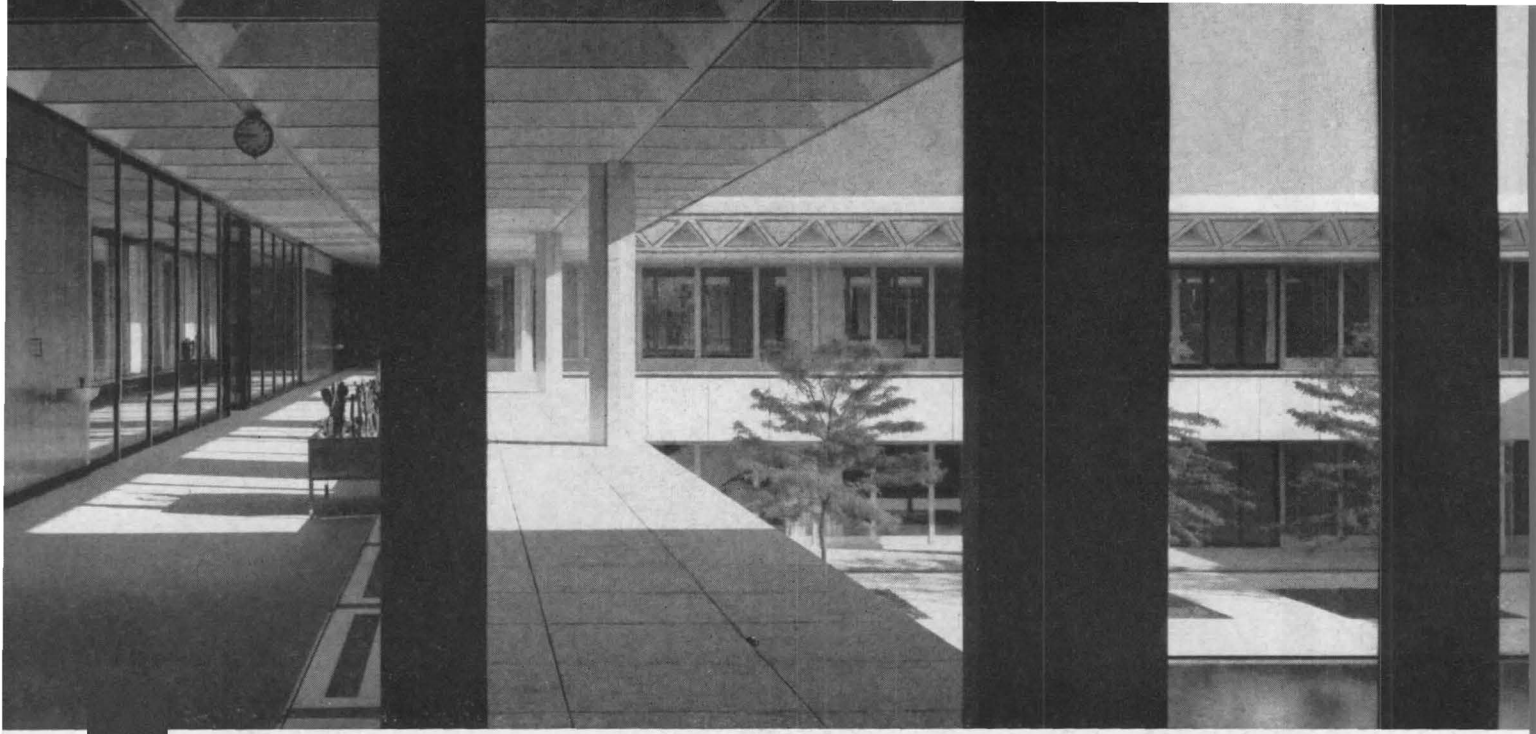



Upjohn Office Building: COURTS PUNCTUATE A SPREADING SQUARE

In essence, the scheme consists of a single spreading pavilion 432 ft square, approached and serviced from below; and punctuated by a series of various sized courtyards. The largest of these—left center in the plan, and pictured at left—extends through both levels to become an impressive entrance yard; the remainder of the courts are smaller in scale and one story high.

The pavilion is sheltered by a steel space frame supported on metal clad columns—Greek cross shape in section—spaced 48 ft on centers both ways. The space frame is effectively expressed by the continuous coffered ceiling of 6 ft square pyramids of reinforced plaster, and by the aluminum perimetric frieze of tetrahedrons.

The strong structural statement gives cohesive unity to a variety of spatial experiences within a changing scale pattern that progresses from the bold strokes of the motor entrance (p. 103) through the entrance court to the almost Japanese character of the smaller courts (p. 109). Flooring materials for both interior and exterior areas were carefully chosen to maintain the flow of scale from large to small, and to express in visual terms the use of space.

General Office Building, The Upjohn Company, Kalamazoo, Mich.

Skidmore, Owings & Merrill, Architects & Engineers

Sasaki, Walker & Associates, Landscape Consultants

Edison Price, Lighting and Fixture Designer

Richard Kelly, Consultation for entrance and wall washer lights

Virginia C. Mosely, Interiors Consultant

O. W. Burke Co., General Contractor



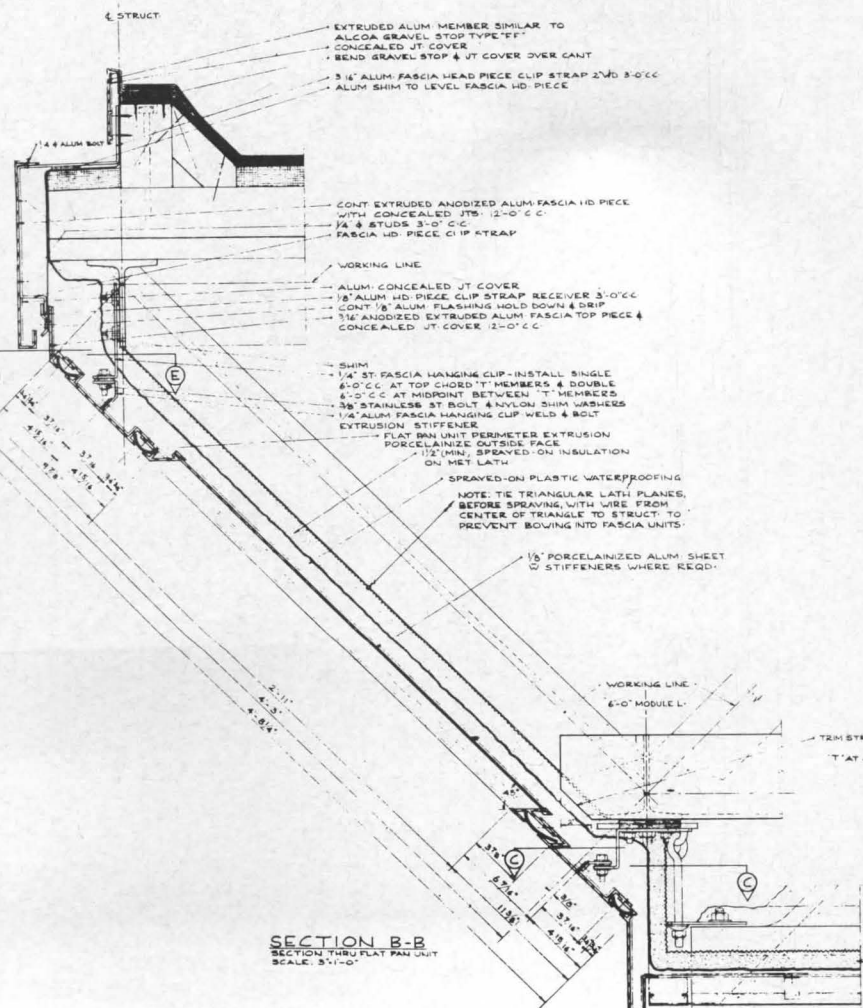
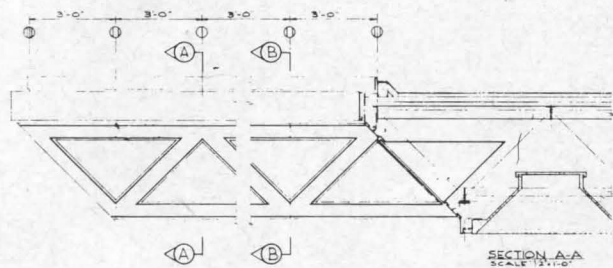
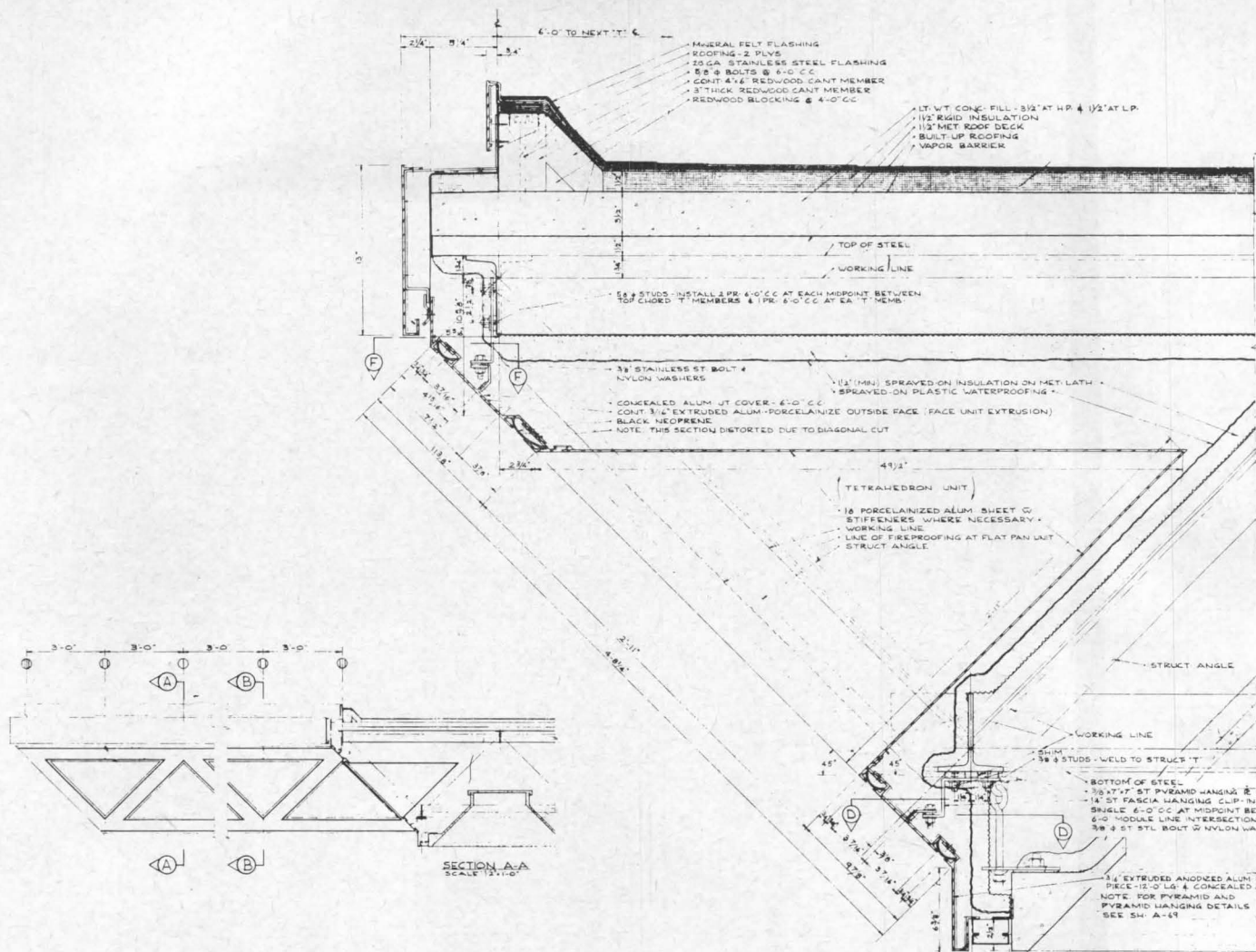

SECTION B-B
SECTION THRU FLAT PAN UNIT
SCALE: 3/4"

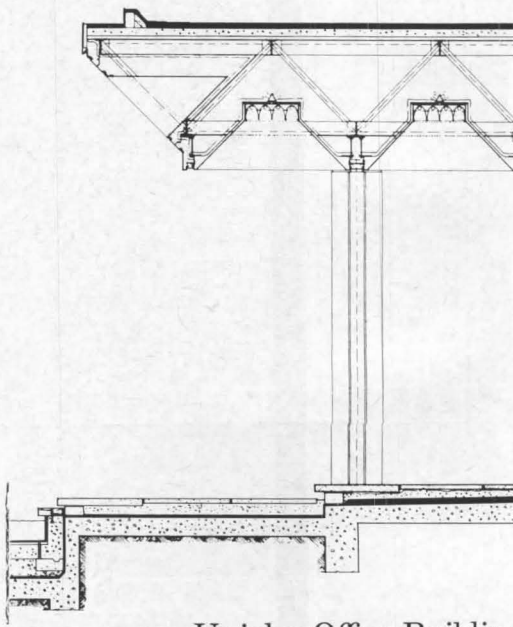

Upjohn Office Building
SPACE FRAME DETAILS

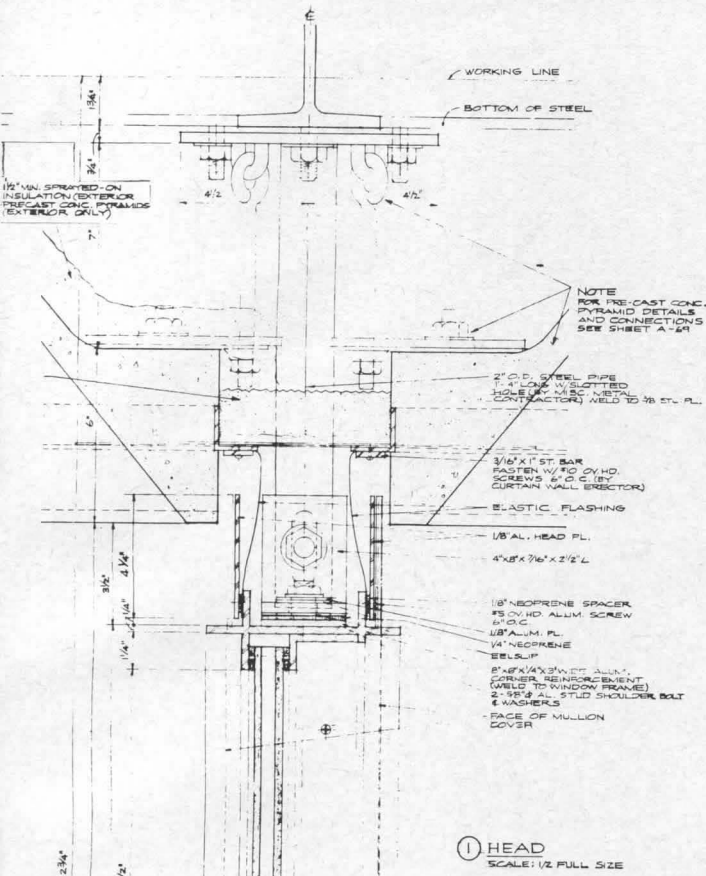

Williams & Meyer Co.

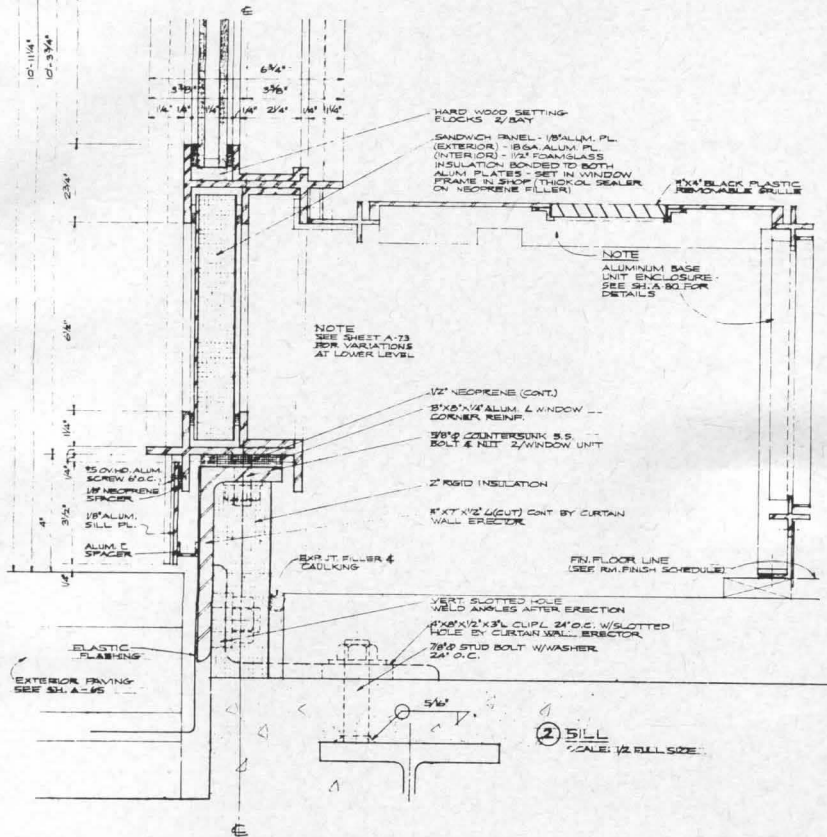

The architect's working drawings are reproduced to show the handling of the space frame and glass curtain. The 3-ft deep space frame was analyzed mathematically and this analysis verified by load testing a scale model and a full-size mockup.

The lighting units, which comprise the top of each ceiling pyramid, were designed by Edison Price in collaboration with

SOM. They are a square composed of 4-24 in. lamps above baffles that virtually eliminate the light source from direct view. The ballast assembly tops the fixture (see detail). The result is notable; a soft, pervasive luminescence pleasantly free of glare, yet affording a quality of direct light desirable for reading and for correct modeling of form and texture.

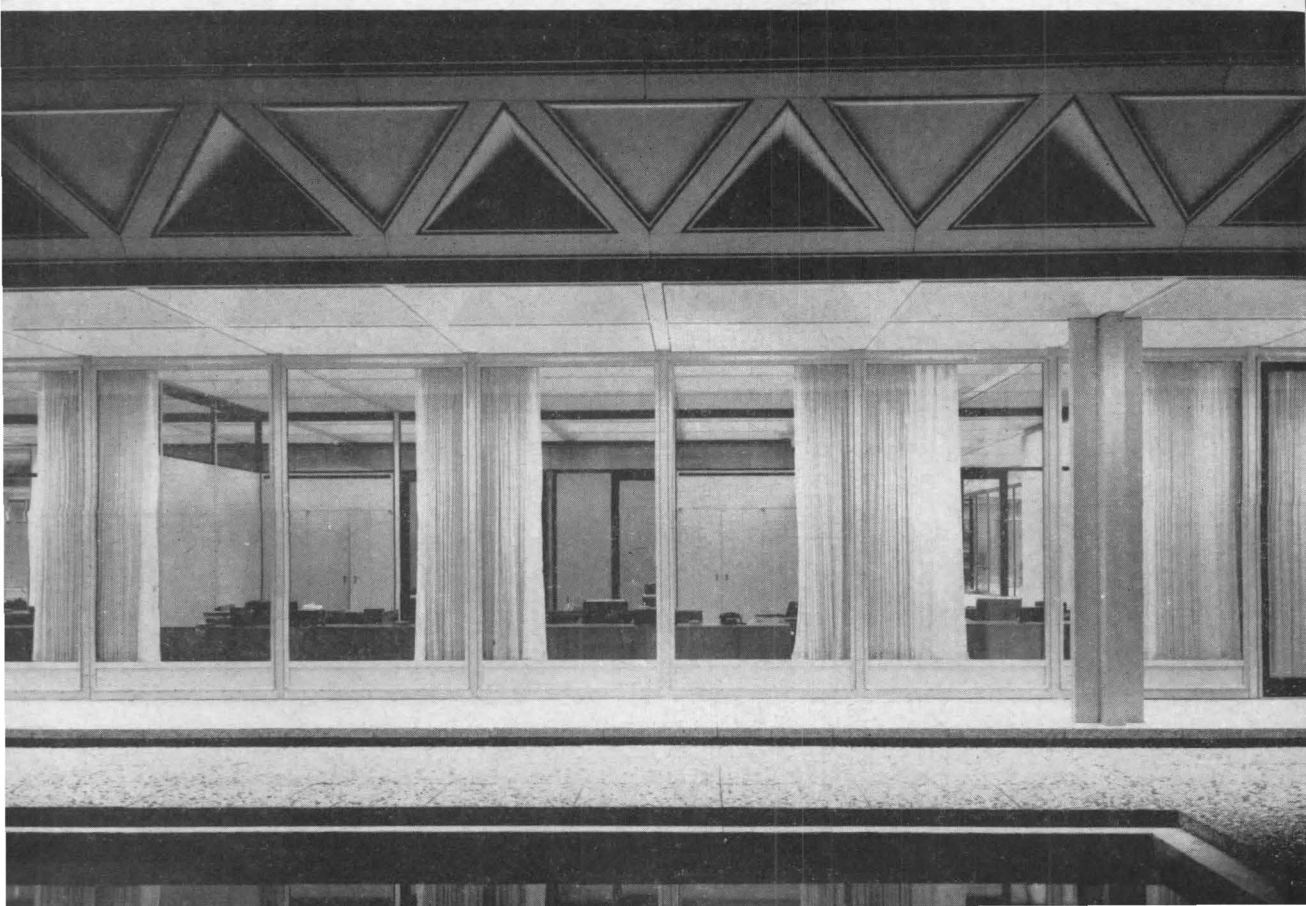
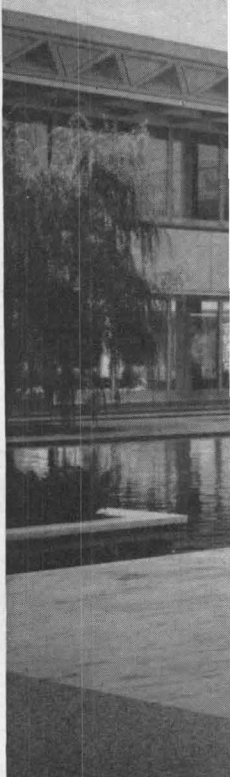



Upjohn Office Building
THE COURTYARDS

Several of the courtyards are shown on these two pages, so the reader may gain some idea of the variety in their size and treatment. They reflect faithfully the scale progression of the building—from the expansive, two-story, 150 ft-square entrance yard and pool (above) to the more intimate, Japanese-like character of the one-story, 50 ft-square garden spaces. At left, the bottom photo shows a detail elevation shot of the glass curtain, lighting effect, and space frame edge pattern as they appear at dusk

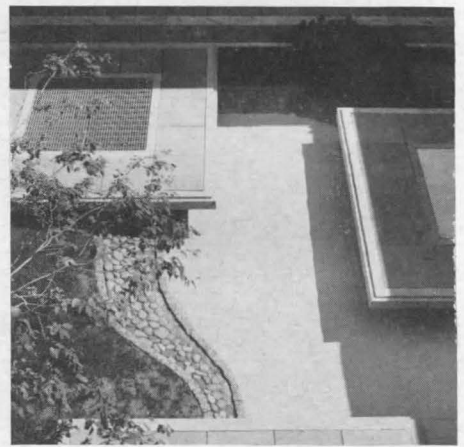

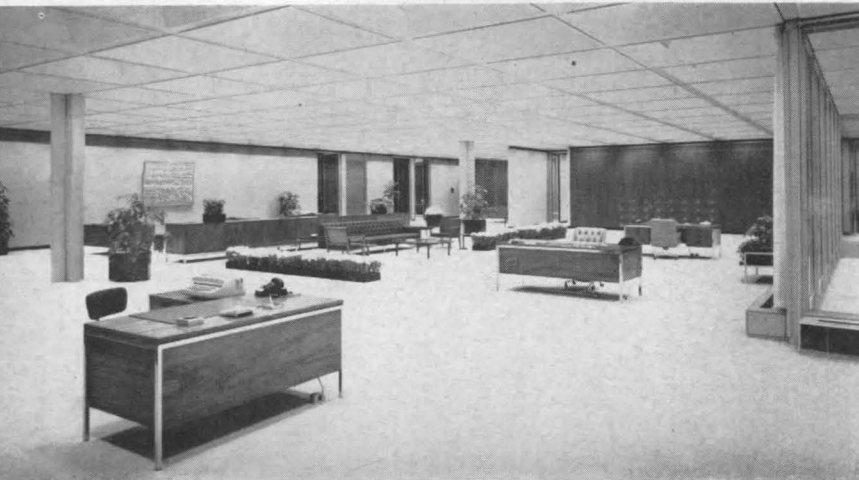

Upjohn Office Building
INTERIORS

The photo below shows a reception area at lower level, overlooking the large entrance courtyard. The lower structure is of concrete and therefore has flat ceilings.

Above, one sees a reception and secretarial area; and to the right, a typical private office. The effect of the coffered ceiling lighting is such that the source is nearly invisible, and the greatest intensity of illumination occurs on desks and the floor. A noteworthy aspect of the interiors is their quality of uncluttered, flowing spaciousness





Warren Reynolds

A Church for the Deaf

Good lighting, both artificial and natural, and good sight lines were prime factors in Ralph Rapson's design for a low budget Lutheran church for worshippers who must follow the service by reading the minister's lips

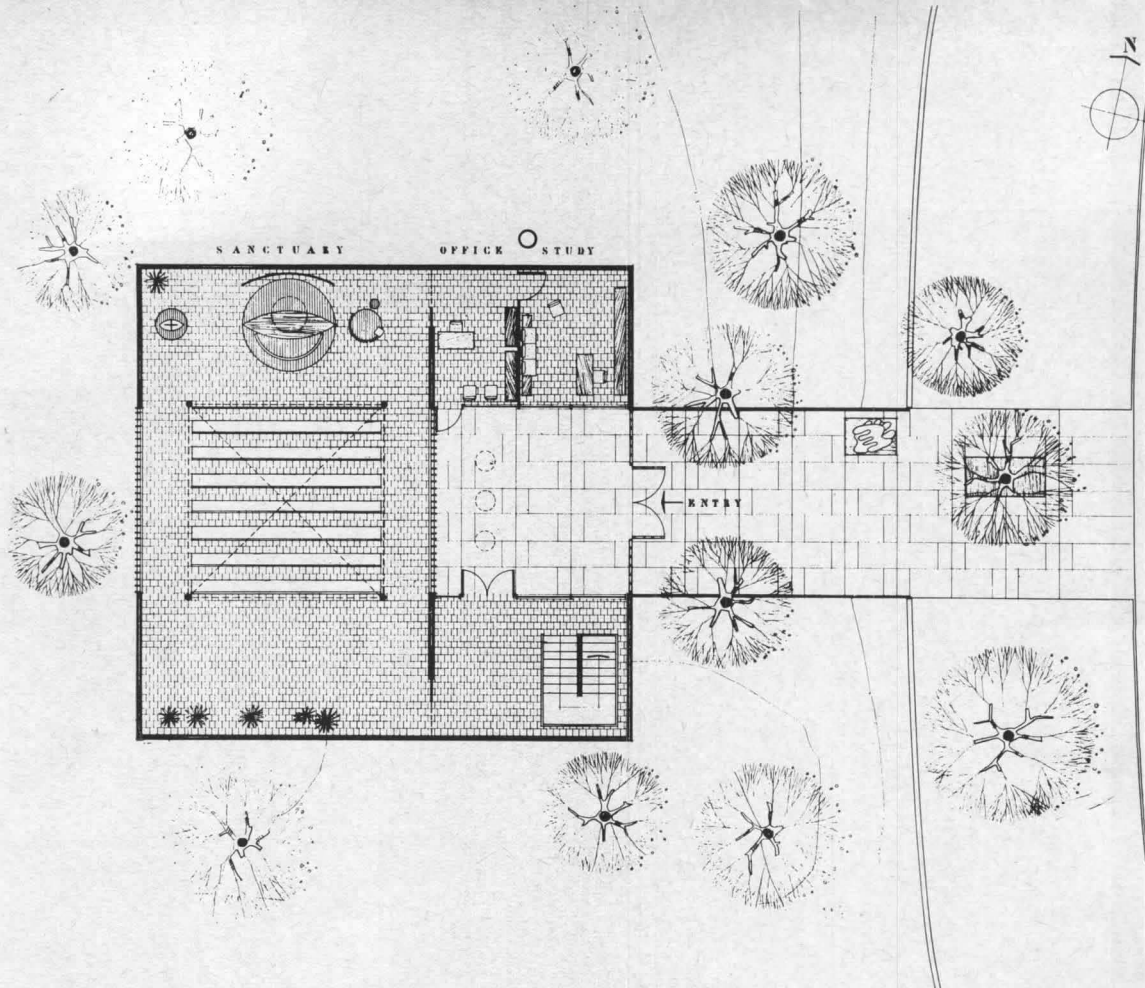

First floor plan

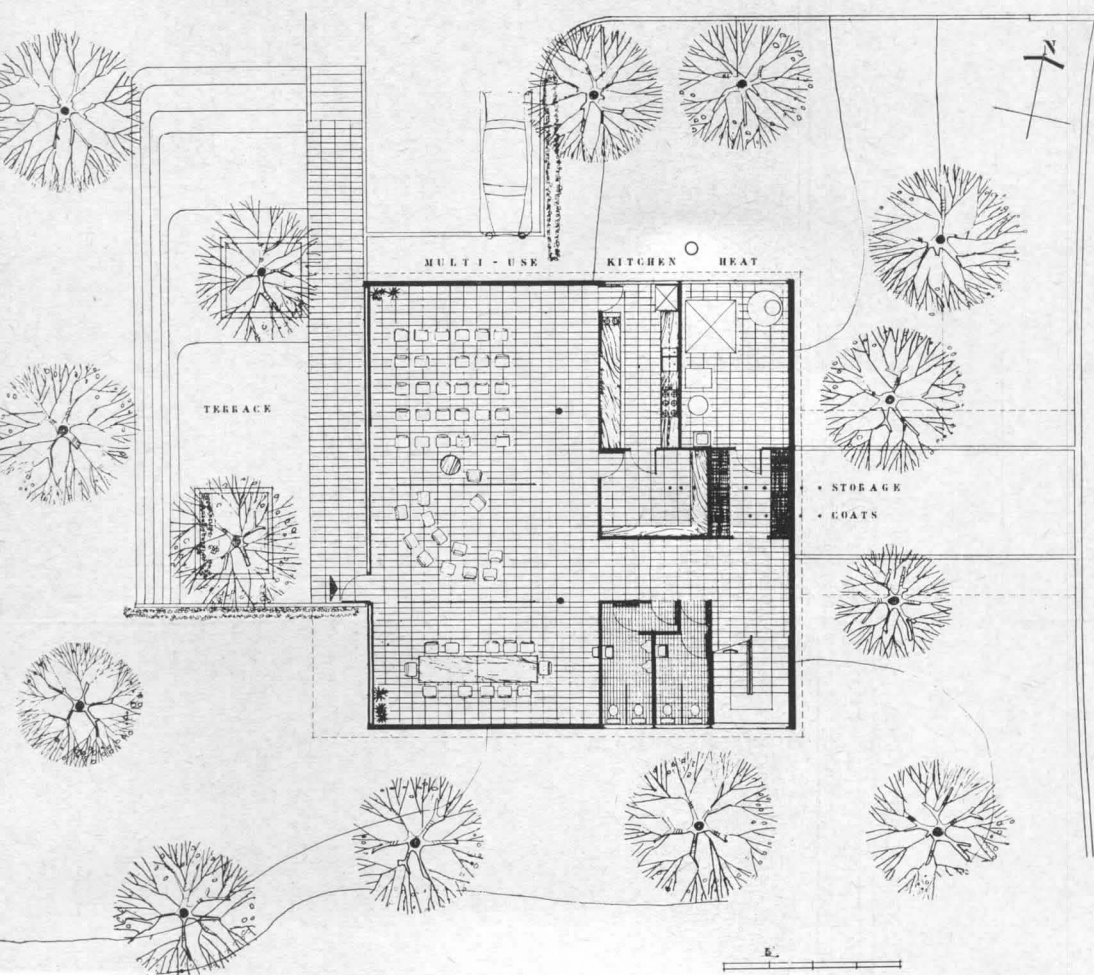

Basement plan



Above: view from north. Below: main entrance. Design character of church reflects its location in fine residential neighborhood.

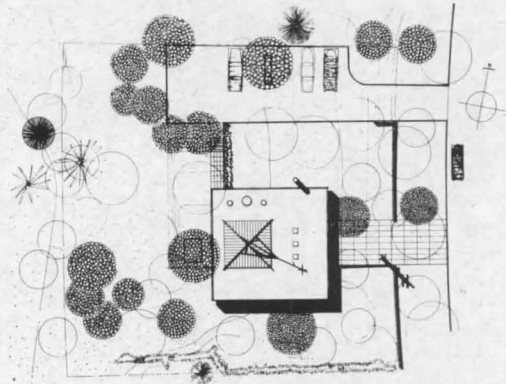

Warren Reynolds

NAME: *Prince of Peace Lutheran Church for the Deaf*
 LOCATION: *St. Paul, Minnesota*
 ARCHITECTS: *Ralph Rapson, Rapson Architects*
 STRUCTURAL ENGINEERS: *Meyer and Borgman*
 CONTRACTOR: *Isadore and William Goldetsky*

This church for the deaf would be of interest even if it were not for its special function because it is an unusually handsome structure built within a strictly limited budget. As well as serving as a church, the building is the vital social and educational center for the deaf people of St. Paul. Built for \$73,335 (not including \$3,000 for landscaping, retaining walls, bridge and furniture) at a unit cost of \$13.30 per sq ft, it seats 120 persons in fixed pews with overflow and expansion space for approximately 50 additional seats. Educational facilities are provided in the basement for approximately 75 to 100 children.

The court plan with connecting bridge to the street was conceived to give the deaf people a semi-private area for comfort and relaxation. The court permits overflow and expansion. At the basement level the terrace provides vitally needed additional social and educational space.

The structure consists of precast concrete floor panels, concrete block basement walls, stacked-bond brick cavity walls on the upper level and wood roof construction. A forced warm air heating system is used with provision for future air conditioning.

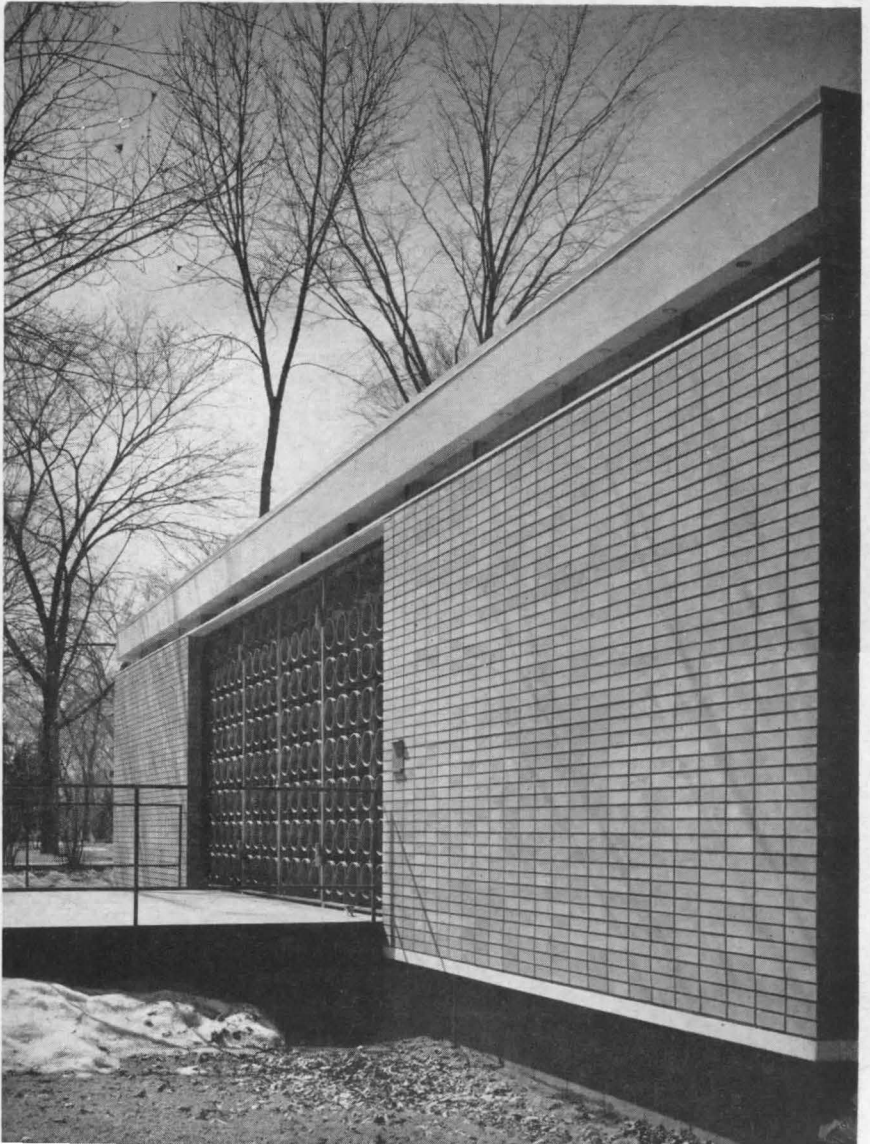



The roof is separated from the wall structure providing a continuous halo of light as part of the design approach which provides a high level of illumination from both natural and artificial sources to facilitate lip reading. Interior walls are brick with a sand finish. Plaster ceilings and pews are painted white for high reflectivity as well as appearance

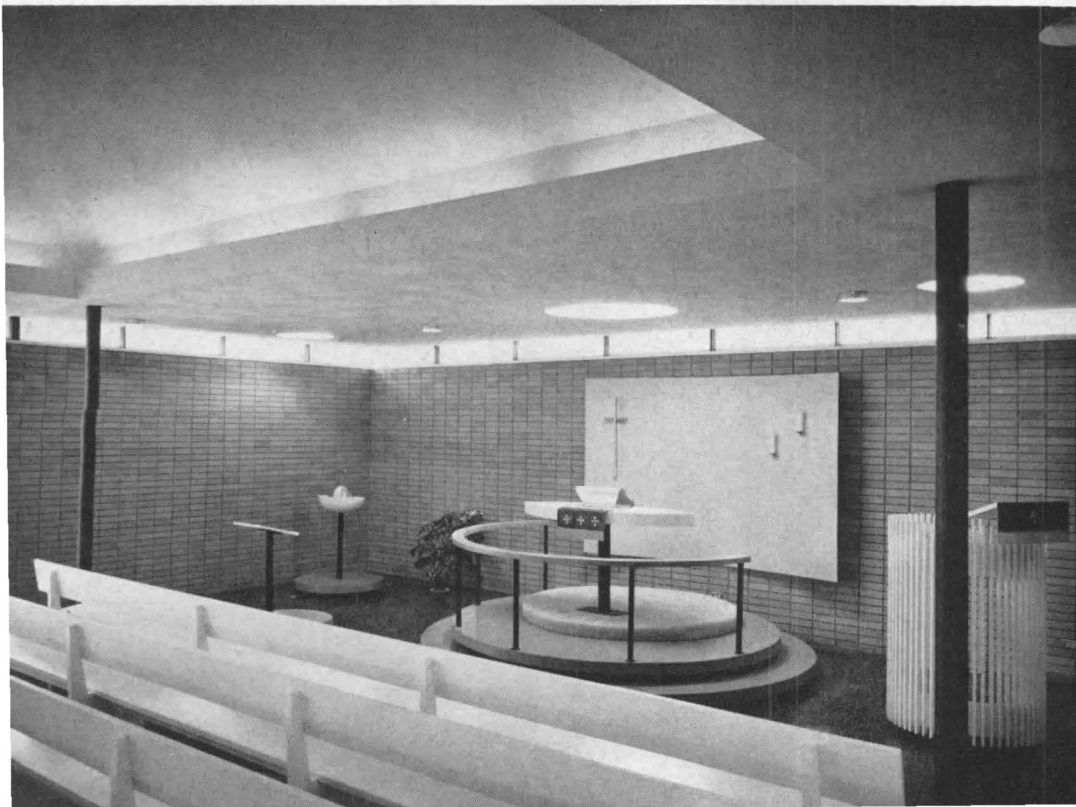

Recent British Church Design: An Agreement to be Radical

by Peter Hammond

The Reverend Peter Hammond, a leading British critic of church architecture and author of the well known book on contemporary English churches *Liturgy and Architecture*, here describes and criticizes recent British churches which best express changing liturgical thought

From the early fifties onwards a steady stream of illustrated surveys of modern churches has poured from the continental and American presses. In most of these books, as well as in the numerous periodicals dealing with modern church design, the work of British architects has been virtually ignored. This is understandable: as recently as two years ago there was scarcely a single example of authentic modern architecture to be found among all the hundreds of new churches built in this country since the early thirties. The monumental survey *Kirchen*, published in Munich in 1959 and containing photographs of postwar churches all over the world, includes only two examples of British church architecture, and it is significant that one of these is the only church in the whole book based on a plan which is still widely regarded in this country as the "normal" or "traditional" layout for a parish church: "traditional," in English ecclesiastical parlance, usually means "late 19th century."

A few determined editors have scraped the barrel to produce a church or two, usually from the New Towns or the suburbs of Coventry, designed in what is commonly described as "a contemporary idiom" or "the modern style," and is in fact largely a by-product of the Festival of Britain. The still unfinished Anglican cathedral at Coventry, in many ways the most impressive monument in this genre, is too large to ignore; but it tends to baffle Continental writers, who characterize it as "*une solution d'un romantisme très nordique*," or, like M. Pichard, regard it as a sign that "*l'Angleterre s'engage dans un renouvellement de l'art religieux très nourri de symbolisme*."¹ Elsewhere, one may find a passing reference to the work of Eric Gill (who died twenty years ago), to Graham Sutherland's painting and Henry Moore's sculpture at St. Matthew's Northampton; perhaps to George Pace's restoration of the medieval cathedral at Llandaff, in Wales, and to the Epstein *Majestas* which now dominates the nave. That is about all, and it does not amount to very much; certainly not enough to justify another essay on church architecture in Britain.

In actual fact, the last four years have seen the beginnings of a debate about church design which could lead to a revolution in British ecclesiastical

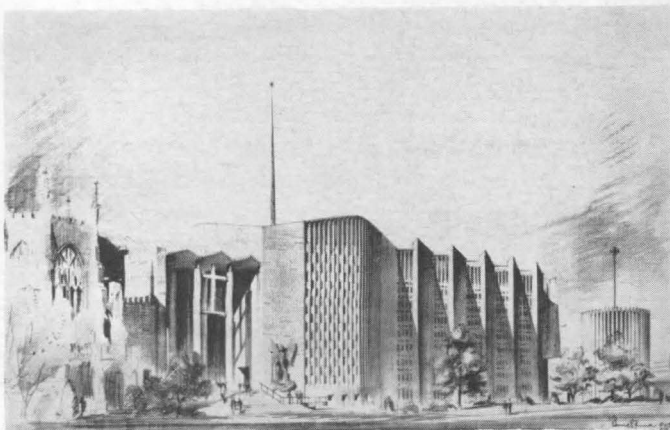

Coventry Cathedral by Sir Basil Spence and Partners

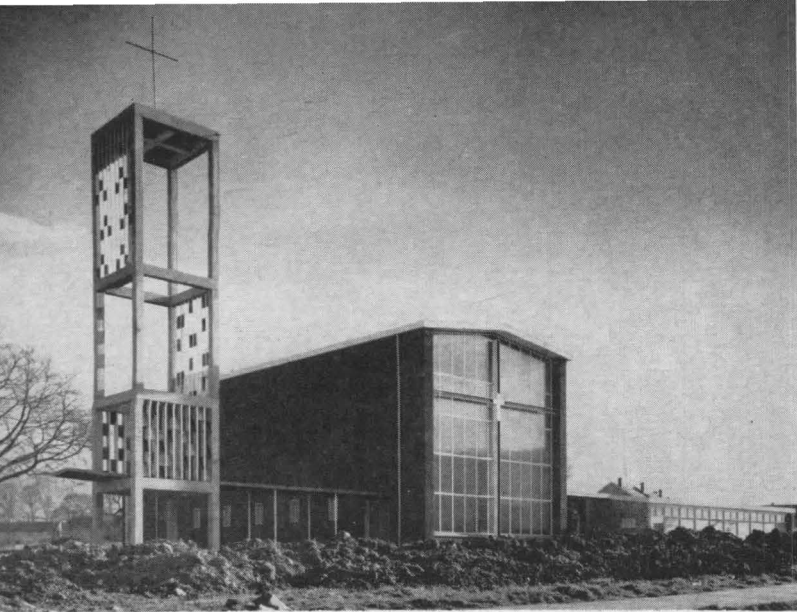

Anglican parish churches at Willenhall (exteriors) and Tile Hill (interior) Coventry, 1957. Architects: Sir Basil Spence and Partners

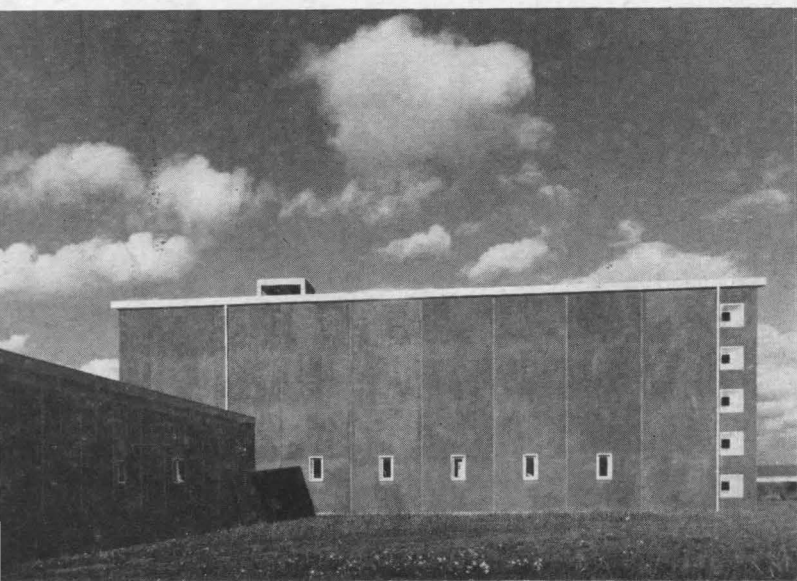

Typical examples of conventional nineteenth century planning uninformed by functional analysis. Despite the use of new materials and structural systems no attempt has been made to think out afresh the nature of the activities which these buildings serve. They reflect an essentially medieval understanding of the Church and its liturgy: a popular *idea* of a church. The old pictorial preoccupations persist. The altar at Tile Hill forms one element in a two-dimensional 'composition'. Like the new cathedral at Coventry these churches merely exemplify new ways of evoking familiar associations



architecture, quite as radical, and based on sounder foundations, than that which took place during the years from about 1840 onwards as a result of the work of the Cambridge Ecclesiologists. While it is far too early yet to speak with any confidence of a renewal of church architecture in Britain, there has without question already been a decisive change in the intellectual climate and this is now beginning to bear fruit in the shape of a few genuine modern churches—as distinct from the essays in vestigial historicism and “contemporary” fancy dress with which we are all painfully familiar. I strongly suspect that in years to come architectural historians will regard the period from 1957 to 1960 as marking a real watershed in the development of church architecture in this country. It is no longer true that the cause of modern church design in Britain is bound up with the churches of Sir Basil Spence and the work of the stained glass department of the Royal College of Art. On the contrary, the kind of approach to church architecture which has produced the new cathedral at Coventry is now widely recognized, by churchmen and architects alike, as a hang-over from 19th century romanticism.

In a recent essay on the development of the modern movement in Britain Sir John Summerson asserted that there is today what there was not twenty years ago, a real school of modern design in this country. He was careful to add that what he had in mind was not “national character” or “Englishness” or anything like that, but rather the very general agreement that one finds today among serious British architects as to what is the right approach to modern building. This agreement, he pointed out, “goes deeper than a sharing of stylistic conventions, which come and go fashionwise; it is an agreement to be radical, to be continuously critical of results, and to go back again and again to the program and wrestle with its implications . . . This radicalism is the great thing in English architecture today. Once lose it and ‘English modern’ becomes just so much provincial back-wash from the Channel and the Atlantic.”²

It is of course in the field of school design that the effects of this radicalism can be most clearly seen today. The outstanding success of our school building program since the war has been very largely due to the readiness of those concerned to start from first principles, to ask fundamental questions, and to modify theoretical conclusions in the light of systematic criticism of results. Where church architecture is concerned one finds an entirely different approach. The one question which, prior to 1957 at least, was *never* asked was precisely: “What is a church *for*?” It was generally assumed that the purpose of a church was fixed and unchanging; that the architect’s task, so far from involving any re-assessment of recent tradition in the light of first principles, let alone the painstaking analysis of the human

and social activities which the building served, was simply one of creating "a devotional atmosphere." In March 1957 one of our most intelligent architectural critics actually began a study of a new church with the words: "I do not have to begin in this instance by analyzing the function of the building. We all know the purpose of a church, which is a simple one in that it is fixed and unalterable and therefore does not involve the architect in a search for improvements in the program he is set, as a factory often does or a hospital."³ How far we have progressed in the course of four years may be seen by comparing this quotation with another, from a recent number of *The Architectural Review*, in which it is roundly asserted that "to regard the Liturgical Movement as a most promising new source of valid forms in church architecture is to miss its point completely. . . . It postulates a complex of spatial and functional relationships between priest and congregation, the ritual and the instruments of ritual . . . The Liturgical Movement relieves the architect of neither functional nor formal responsibilities. It sets a program . . . Its interest for the architect lies in the kind of brief it will give him when he is asked to design a church—not vaguely emotive in the recent atmospheric manner, not fanatically precise over trivia, as with the Ecclesiologists of the last century, but concerned with functions and people. Such a brief, while in no way impairing the religious qualities of the building—quite the other way about—puts the conceptual stages of church design on the same imaginative and intellectual footing as applies in the most forward areas of secular architecture at present." As the writer goes on, this is an approach which makes it possible for architects "to tackle church design without feeling—as has so often been the case—that they are abandoning the moral fundamentals of their architecture, based on truth and honesty in material and function, and relapsing into a theatrical pseudo-mysticism."⁴ Clearly, a great deal has happened since 1957.

I do not propose to describe in any detail the events which have brought about this decisive change in the climate of church building. All else apart, I have been far too closely involved in the debate to be capable of writing about its rapid development with the necessary detachment. It may, however, be useful to recall a few of the more important landmarks.

In January 1957 the publication of that most depressing survey, *Sixty Post-War Churches*, brought home to many people the fact that an immense opportunity was being entirely wasted: that hundreds of thousands of pounds were being squandered on buildings of the most deplorable quality, few of which even merited serious criticism. In April, in a correspondence in the pages of *The Architects' Journal*, the concept of "the program" was first in-

troduced into the public discussion of church design in this country by Robert Maguire and Keith Murray—whose first church, at Bow Common, in the East End of London, was then at the project stage. In May, I drew attention in a broadcast talk to the lamentable situation disclosed in *Sixty Post-War Churches* and stressed the need for a fresh approach to the whole business of designing a church: an approach starting from the fact that a church is first and foremost a house for a worshipping and missionary community—not an autonomous monument or a pavilion of religious art. I pointed out that the problems which needed to be faced were theological rather than "artistic," and I underlined the importance for church architecture of the movement for radical reform within the Church which is commonly (though not altogether happily) known as the Liturgical Movement. Finally, I stated the case for setting up some kind of research institute where architects, theologians, pastors and sociologists could tackle the problems of church design within the context of changes in the Church's understanding of itself, its worship and its mission in contemporary society.

The response to this talk made it quite clear that others were thinking along the same lines, and in June a small group of clergy and architects met for two days near Cirencester to discuss possible courses of action. As a result of this meeting an association was formed, primarily for study and research, but with the further aim of fostering, not least in official ecclesiastical circles, a greater awareness of the questions at issue. In 1958 this was enlarged and given a rather more formal character as the New Churches Research Group; a manifesto was published, a series of occasional papers launched, and several conferences were organized with the cooperation of university departments for extramural studies. Since then the campaign for a radical approach to church design has steadily gathered momentum. Conferences, local and denominational study groups, lectures and publications have all played their part in creating a new climate of opinion. The annual conferences and study tours organized by the University of Birmingham have stimulated interest in what is being done on the Continent. In April 1960 the consecration of the church of St. Paul, Bow Common, and the publication of my own book *Liturgy and Architecture* gave a considerable boost to the movement for reform, and it was observed that church architecture had become a subject fit for serious discussion in the columns of *The New Statesman*.

Even in official circles the new ideas have been winning support, and in the summer of 1960 the National Assembly of the Church of England passed a resolution calling for the setting up of a special commission to prepare a statement of advice for those building new churches. This commission has now

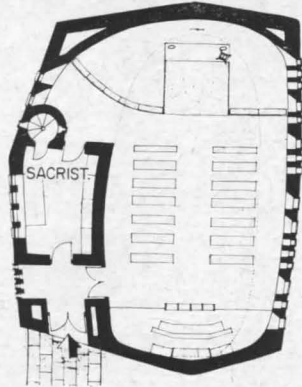
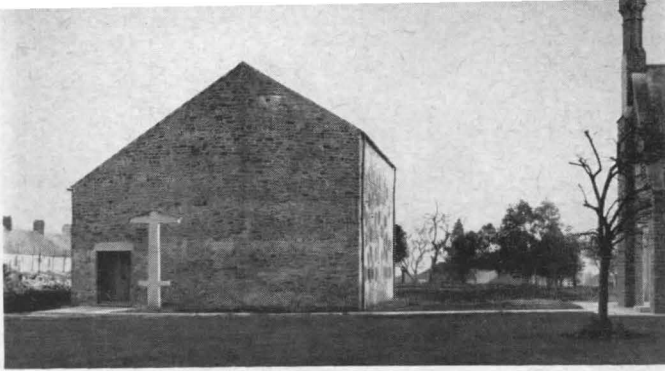

Chapel of St. Michael's College, Llandaff. Architect: George Pace. A small chapel for an Anglican theological college, completed in 1958

Below: Roman Catholic parish church at Glenrothes New Town (1959). Architect: J. A. Coia. A very simple brick structure including church and presbytery. A parish hall will eventually be built to the northwest of the church

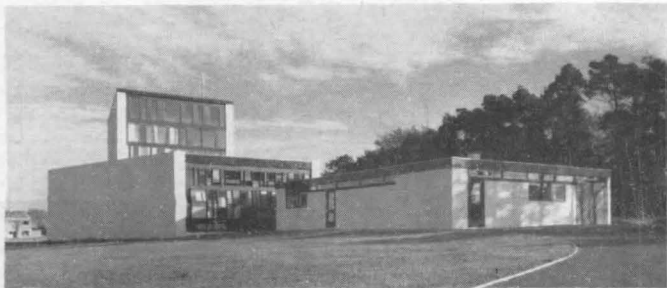
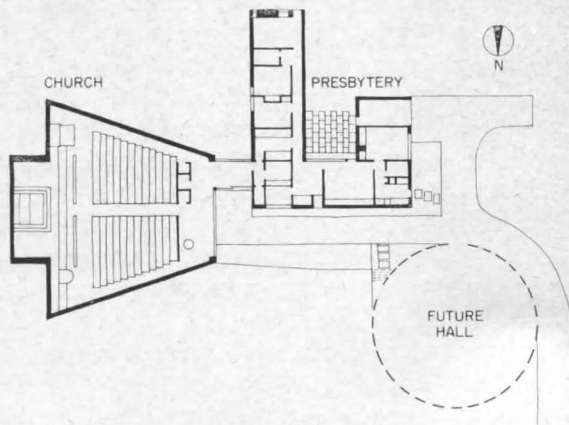

been formed, a majority of its members being drawn from the New Churches Research Group, and its work is likely to result in the publication of an official document incorporating the results of much of the fresh thinking of the last four years. This is again a notable sign of the progress made since 1957.

What in fact has been achieved? I think that the most encouraging aspect of the present situation is the growing recognition that the design of a church, like that of any other building, must start from the analysis of human activities. One has to begin by emptying one's mind of architectural concepts in order to ask: "What are people going to *do* in this building?" A church is primarily a functional structure serving the complex of communal acts which are known collectively as *liturgy*; it should, as Reyner Banham puts it, "support this program of religious acts as snugly as a modern school supports the program of current advanced pedagogy." It is hardly necessary to add that this kind of approach to church design inevitably means a great deal of hard thinking about the nature of the activities which the building should serve and articulate. For example, it is impossible to establish a satisfactory spatial relationship between the baptistery and the eucharistic room without first analyzing the theological relationship between baptism and Eucharist. The layout of the Eucharistic room itself demands a consideration of the nature of the community which participates in the weekly assembly of the local church. Again, the outward form of the church building inevitably depends to a considerable extent upon the changing relationship between the Church and society at large; the size of a church is bound up with that of the pastoral unit which it serves. In brief, it is impossible to abstract church architecture from its social context or to consider the form of a church building in isolation from current developments in theology, liturgy and sociology. This is what I mean by a radical approach to church architecture.

There is always a certain time-lag between the intellectual acceptance of new ideas and their embodiment in actual buildings. This is likely to be particularly marked when the ideas themselves strike at the root of established procedures and where, as in Britain today, responsibility for commissioning architects and approving their designs is to a great extent vested in local committees which are still quite unconscious of the need for reform. It has to be recognized that, despite the changes that have taken place in the climate of opinion during the last four years, there has as yet been no general improvement in the architectural character of most of the buildings erected during this period. Church architecture is still dominated by pictorial and romantic preoccupations; few of the churches built between 1957 and 1960 reflect the new concerns

which have already transformed the whole character of the debate about church design in this country. I have often wished during the last four years that it was possible to call a halt to church building for a time, so that clients and architects alike could face some fundamental issues.

Nevertheless, things are beginning to happen. As long ago as 1952 George Pace's design for a university chapel at Ibadan marked a decisive departure from the conventions of High Victorian church planning, and several modest churches built by this architect within the last five years stand out from the general run of recent buildings by virtue of their simplicity, their straightforward handling of natural materials and their adaptation to the exigencies of the liturgy. The Roman Catholic parish church of St. Paul, at the New Town of Glenrothes, in Scotland, which was consecrated in 1959, showed quite clearly that the same concerns which had already transformed church architecture in Continental countries affected by the Liturgical Movement were beginning to extend to the British Isles. The wedge-shaped plan and shallow rectangular sanctuary make possible a high degree of congregational participation in the liturgy. The relationship between the various buildings forming part of the whole parochial center is carefully studied, and the architectural treatment provides a refreshing contrast to the vestigial historicism which had hitherto prevented even the more enterprising experiments in the adaptation of the plan to modern liturgical requirements from rising to the level of serious architecture.

But the most impressive embodiment of the new approach which I have been describing is undoubtedly the Anglican parish church of St. Paul, Bow Common, completed early in 1960. Here for the first time is a church exemplifying the radicalism and the readiness to go back again and again to the program which Sir John Summerson regards as the hallmark of serious architecture in this country. As I wrote shortly after the consecration of the church, this is a major landmark in British ecclesiastical architecture: a pioneer work which promises to be as important in its own field as the village college at Impington, or Denis Clarke Hall's pre-war school at Richmond, in that of school design. It represents the first serious attempt which has been made in this country to apply to the problems of church building the disciplines of functional analysis which have already borne such remarkable fruit in the design of our post-war schools. Here architecture has been shaped by worship; the form of the building springs from and articulates the complex of liturgical values and relationships which provides its *raison d'être*. In its combination of theological and architectural seriousness, its concentration on essentials and its clarity of spatial organization the church seems to me to be one of the very few really outstanding

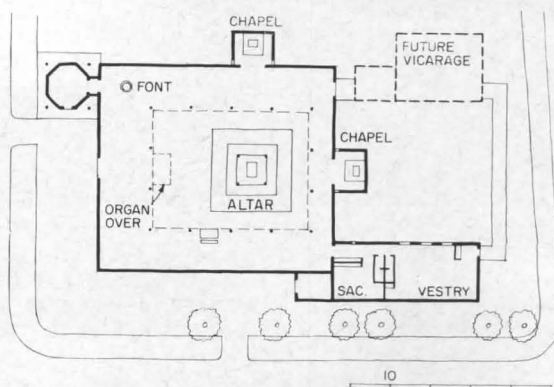
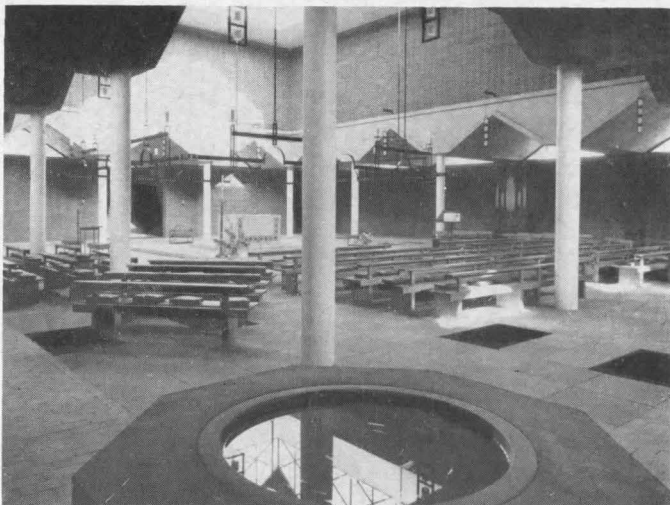
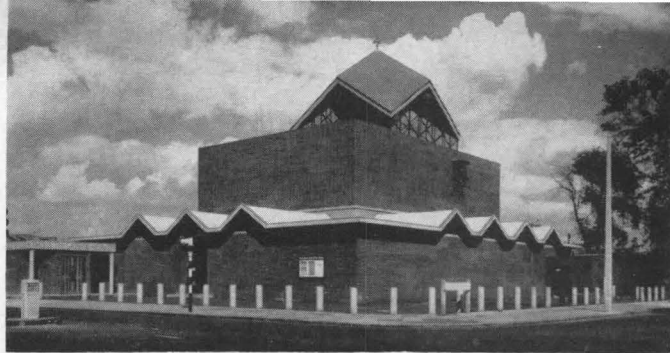

Anglican parish church of St. Paul, Bow Common, London (1960). Architects: Robert Maguire and Keith Murray. A radical departure from conventional planning formulas. The square sanctuary is placed beneath the large, almost central lantern and is further defined by a hanging corona of rolled steel sections. Around the central space is a broad processional way. The church will eventually be surrounded by high blocks of flats. The vicarage, to the northeast of the church, has still to be built. For a detailed study of this church see *The Architectural Review* for December 1960

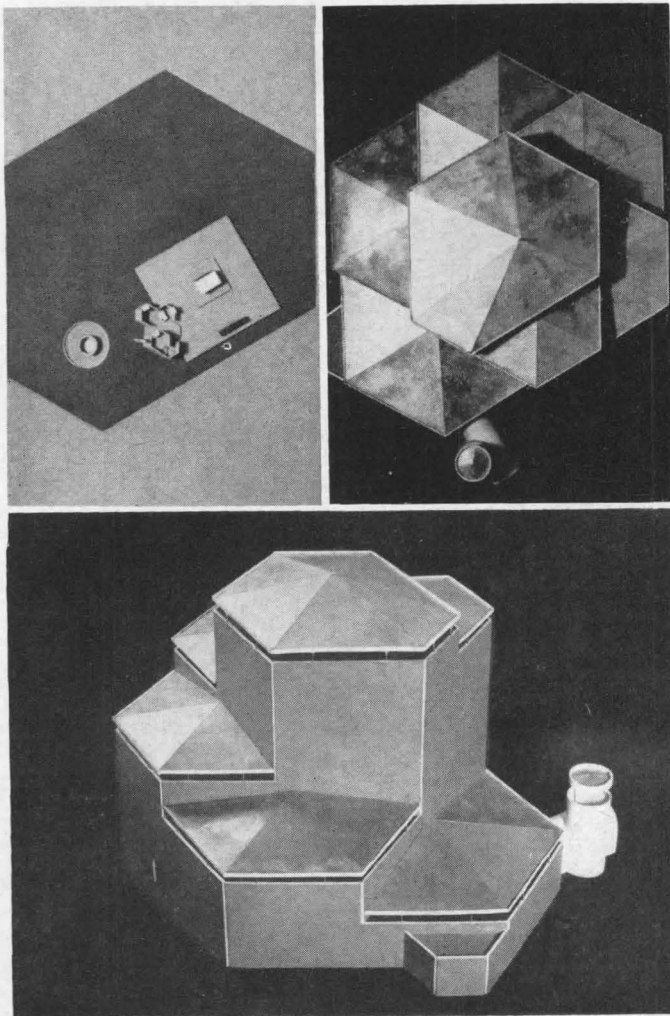
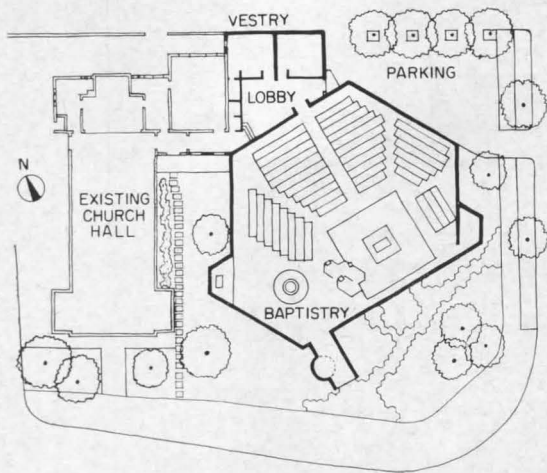

Project for an Anglican parish church at Perry Beeches, Birmingham (1961). Architects: Robert Maguire and Keith Murray. The congregation will enter the church through a baptistery which will form a distinct spatial entity, though it will be visible from the eucharistic room. To the south of the sanctuary is the place for the ministry of the word. The choir and organ are placed to the north of the sanctuary. In this church, as at Bow Common, the seating arrangements will be flexible, and the relationship between the ministers and the whole body of the laity will be determined not merely by the seating but by the spatial organisation of the whole interior

achievements of the last decade: the first major contribution that this country has made to the renewal of sacred architecture. To quote Reyner Banham again, "it serves the needs of the Church without ceasing to be a modern building. Modern, that is, not in terms of current decorative clichés, structural acrobatics or fashionable formalisms, but modern in the sense of the hard core of moral conviction that holds together any number of formal and structural concepts on the basis of what Lethaby called 'nearness to need'." ⁵

A second Anglican parish church by the same architects—St. Matthew, Perry Beeches, on the outskirts of Birmingham—which should be completed before the end of 1962, promises to be no less interesting. Here the parish priest, like the architects, is a member of the New Churches Research Group, and the project embodies the results of a great deal of analysis and reflection; indeed, the program is probably the most carefully considered document of its kind that has yet been formulated. All else apart, this project could be of great exemplary value from the point of view of procedure and it is hoped that a detailed case history may eventually be published.

At Glenrothes New Town—apart from the churches sadly lacking in architectural distinction—another new church is nearing completion. This is the Presbyterian parochial center, including church, large and small halls, manse and ancillary accommodation, designed by Anthony Wheeler and Frank Sproson. It is a notable landmark in the Church of Scotland's post-war building program and a clear sign of the new influences that are now at work. American readers may care to compare this building with the First Presbyterian Church at Stamford, Connecticut (commonly known on this side of the Atlantic as the Stained-Glass Whale). The two churches are the product of widely divergent approaches: the one based on the radical analysis of theological and liturgical principle and human needs, the other on a romantic *idea* of a church stemming from an insufficiently critical view of the Middle Ages as seen through 19th century spectacles.

There are several other churches in this country now at the project stage which show the extent to which the former approach is beginning to issue in actual buildings. They include an Anglican parish church at Rugby, designed by Denys Hinton; another, at Gloucester, by Robert Potter and Richard Hare, whose earlier church at Crownhill, near Plymouth, completed in 1958, is a building of considerable interest from the point of view of the plan; and several recent projects by Norman Haines, including one for a prototype church for new parishes in the Welch diocese of Llandaff. The New Churches Research Group symposium *Towards a Church Architecture*, to be published in 1962, will include a further group of projects illustrating the

progress which has been made within the last four years.

Again, it is encouraging that the whole question of user studies, hitherto entirely neglected, is at last beginning to be faced; this could provide a most profitable field for research projects carried out at the parochial and diocesan level. The need for applying current techniques of cost programming to church building is also at last receiving the attention that it merits; there have been some lamentable examples of extravagant expenditure on bell towers, stained glass, sculpture and similar items, at best of marginal importance and frequently downright meaningless, to the neglect of what is essential. The value of serious cost programming lies above all in the fact that it compels an architect to consider what is of central importance in a church and what is peripheral. It is not without significance that the church at Bow Common is an inexpensive building by English standards, while the Roman Catholic church at Glenrothes cost just about one third of what is commonly regarded as normal and reasonable. By contrast, some of the very worst churches built during the last ten years have also been among the most expensive: the recently completed church of St. George at Stevenage New Town is a notable example.

There were those who hoped that the new radicalism in church design might affect the outcome of the recent competition for the Roman Catholic cathedral at Liverpool. The Archbishop's letter, annexed to the official conditions issued in October 1959, suggested that theological and liturgical criteria might play a more important part in this competition than they had done at Coventry. Admittedly, the conditions themselves were extremely unsatisfactory; it is debatable, to say the least, whether the primary function of a cathedral church is to enable congregations of 3000 to take part in Eucharistic worship; many of us would maintain that genuine participation becomes impossible in a building designed to accommodate more than about 500 people, and that the liturgical function of a cathedral is quite different from that of a large parish church. In any case, such hopes as had been aroused by the Archbishop's letter were somewhat diminished by the appearance of the *Official Answers to Questions* in January 1960, when competitors learned that the assessors, who included the architect of the Anglican cathedral at Coventry, would look first for a splendid conception. Such words had a familiar ring, and the misgivings to which they gave rise were fully confirmed when the results of the competition were announced. Whatever criteria had guided the assessors in their choice of 21 curiously heterogeneous entries for award or commendation, it seemed evident that considerations of use or usefulness had played a very minor role. Among the commended designs was one in which it appeared to be impos-

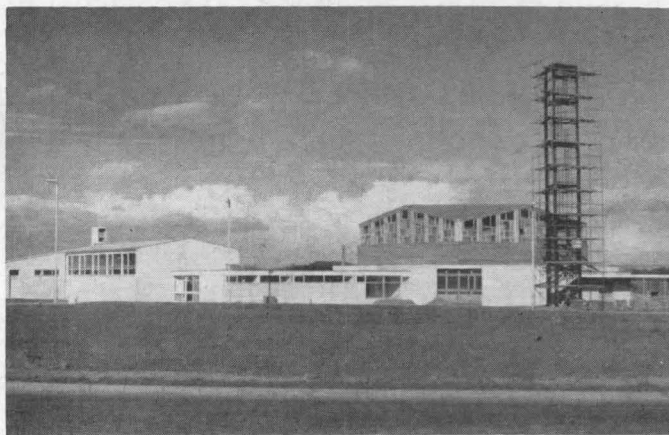
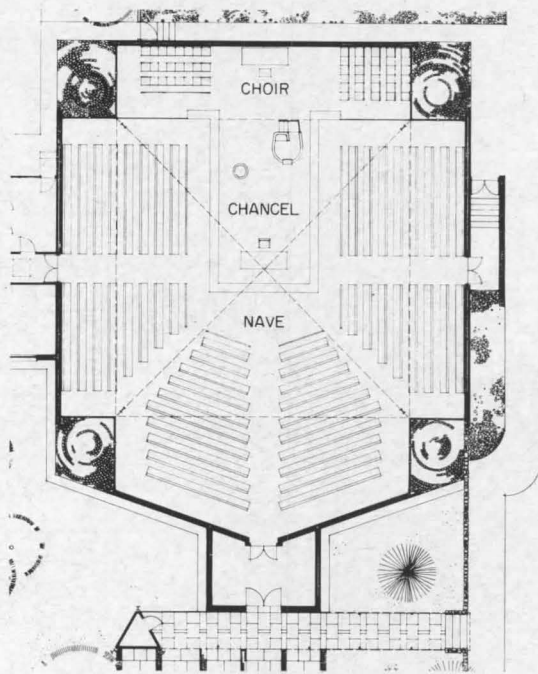

Presbyterian church of St. Columba at Glenrothes New Town (1961). Architects: Anthony Wheeler and Frank Sproson. A parochial center including church, two halls and manse. The plan has much in common with that of the Anglican parish church at Bow Common, though here the choir is placed to the east of the sanctuary and the position of the font reflects current Presbyterian practice

sible to *use* the high altar at all.

But it was the assessors' remarks about Frederick Gibberd's winning design which showed that, despite all that has happened during the last four years, the complex of the monument is still something that has to be reckoned with: that the romantic approach to church architecture still lingers on. The assessors seem to have been unaware of the fact that the plan of the winning design is based on what is now generally accepted to be an inadequate conception of the nature of the liturgical assembly; they were apparently untroubled by any misgivings in regard to the naïve symbolism of the immense crown of thorns or the implied doctrine that form follows dedication. It was sufficient that the winning design "powerfully expresses the Kingship of Christ": that "the visitor will be left in no doubt that this is a temple built to the honor of Christ the King." Clearly a great deal has still to be done before there can be any question of a widespread renewal of church architecture in Britain.

To sum up: while the prospect is far less bleak today than it was in 1957, while the radicalism which is so characteristic of the best secular architecture in this country has at last begun to extend to church design, and while the church at Bow Common provides a foretaste of renewal, the Liverpool competition is a sobering reminder that there are dangers as well as exciting possibilities inherent in the present rapidly changing situation. Although many of the revolutionary assertions of 1957 are well on the way to becoming the popular slogans of 1961, some of them are undoubtedly becoming pretty debased in the process. There is plenty of evidence to suggest that quite a few of the architects who have recently "gone liturgical" have been motivated solely by the desire to keep abreast of what is now commonly regarded as a new fashion, the latest swing of the pendulum. The adoption of a few fashionable planning formulas does not amount to a new approach to church architecture. What happens during the next ten years will depend very largely on our readiness "to be radical and to go back again and again to the program and to wrestle with its implications"; above all, on the recognition that the fundamental problems of church design are problems concerning the nature of the Church itself, the worship which is its characteristic activity, and the relationship between the Christian community and society at large.

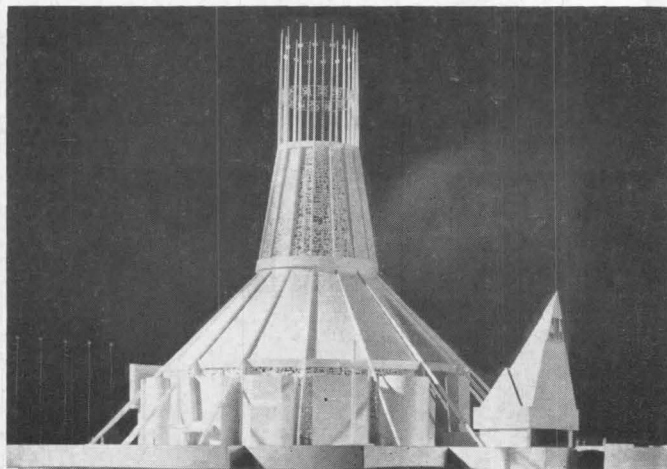

Winning design for the new Roman Catholic cathedral at Liverpool by Frederick Gibberd (1960). A vast wigwam-like structure based on a circular plan with central altar, designed to accommodate 3000 people. The central tower, filled with panels of stained glass, is to be surmounted by an immense crown of thorns. It is instructive to compare this project with secular buildings by the same architect (e.g. at London airport). The possibilities inherent in the implied doctrine that form follows dedication provides a fascinating field for speculation

- (1) *Les Eglises Nouvelles*, by Joseph Pichard. Paris, Editions des Deux-Mondes, 1960, p.105
- (2) Introduction to *Modern Architecture in Britain*, by Trevor Dannatt. London, Batsford, 1959, p.27
- (3) Article by J. M. Richards in *The Architects' Journal* for March 28, 1957, p.459
- (4) *The Architectural Review*, vol. CXXVIII no.766, p.400
- (5) *Ibid.*

A TOWN HOUSE ON A SPECTACULAR SITE

ARCHITECTS: *Anshen & Allen*

LOCATION: *San Francisco, California*

CONTRACTOR: *Hugo Noller Jr., Inc.*

STRUCTURAL ENGINEER: *Robert Dewell*

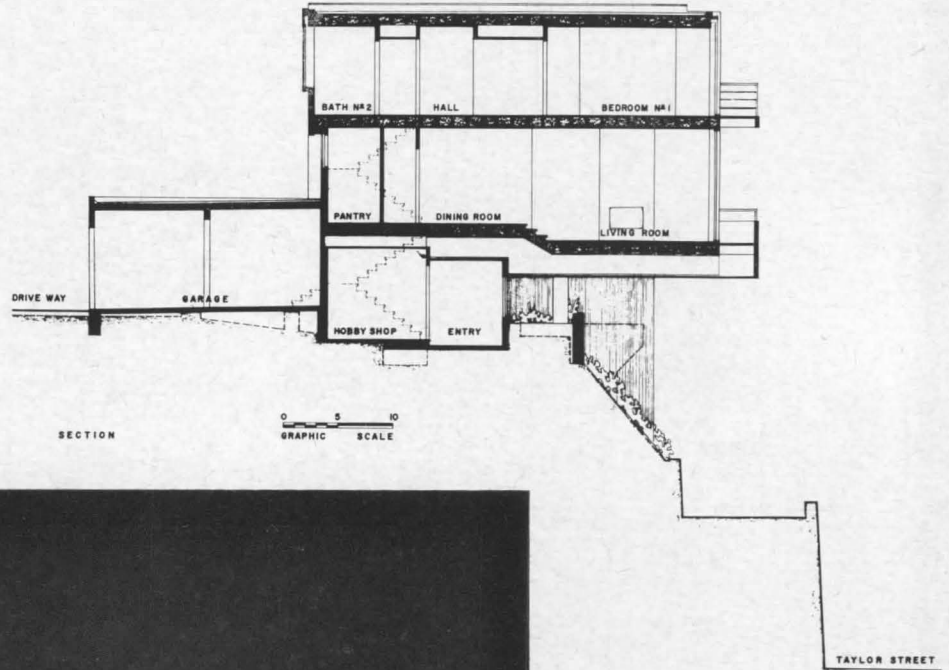

George Knight

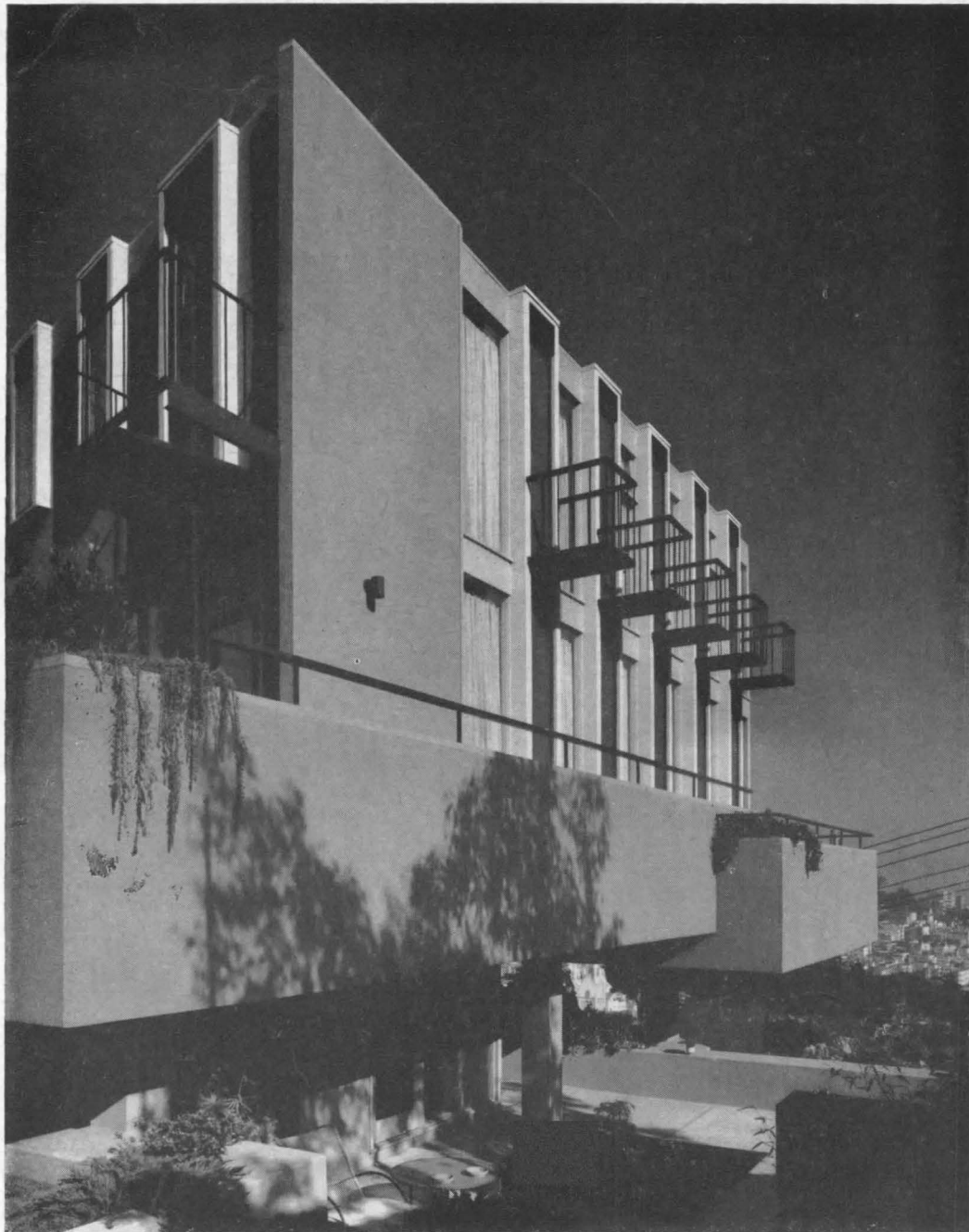

Town House in San Francisco

The wonderful views afforded by one of San Francisco's cascading sites, were very intelligently exploited in this three-level town house. The hilly location, well up from the highways and freeways, drops sharply to the south and east, and adjoins other buildings to the north. The plan reflects this by opening major rooms to the vistas, and by placing the house (with a blank wall) along the northern property line. The main living and sleeping areas are on the upper floors, with recreation and outdoor living areas nestled in privacy at the lower level. Each of the major rooms upstairs also has some access to the outdoors via a terrace or balcony. The upper floors overhang the ground floor to make the best use of the little available level land.

George Knight



The middle, or "living" floor, is essentially an open plan, with a kitchen that can be used open or closed (note photo lower center). The dining area is set apart only by a slight change in floor level. The L-shaped fireplace wall includes built-in bookcases, hi-fi, and a niche for a piano.

The structure of the house is a combination of wood frame and steel columns and girders. Foundations are concrete. The exterior, which makes a design feature of the balcony doorways, is of stucco and wood trim, painted in three shades of terra cotta. The roof is 4-ply, with asbestos finishing felt, and has wool batts for thermal insulation. Windows have steel casements; plastic domes are used over interior bathrooms.

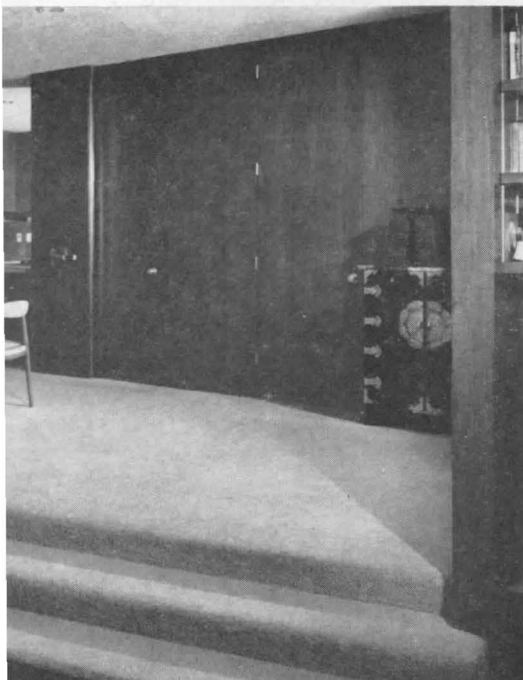
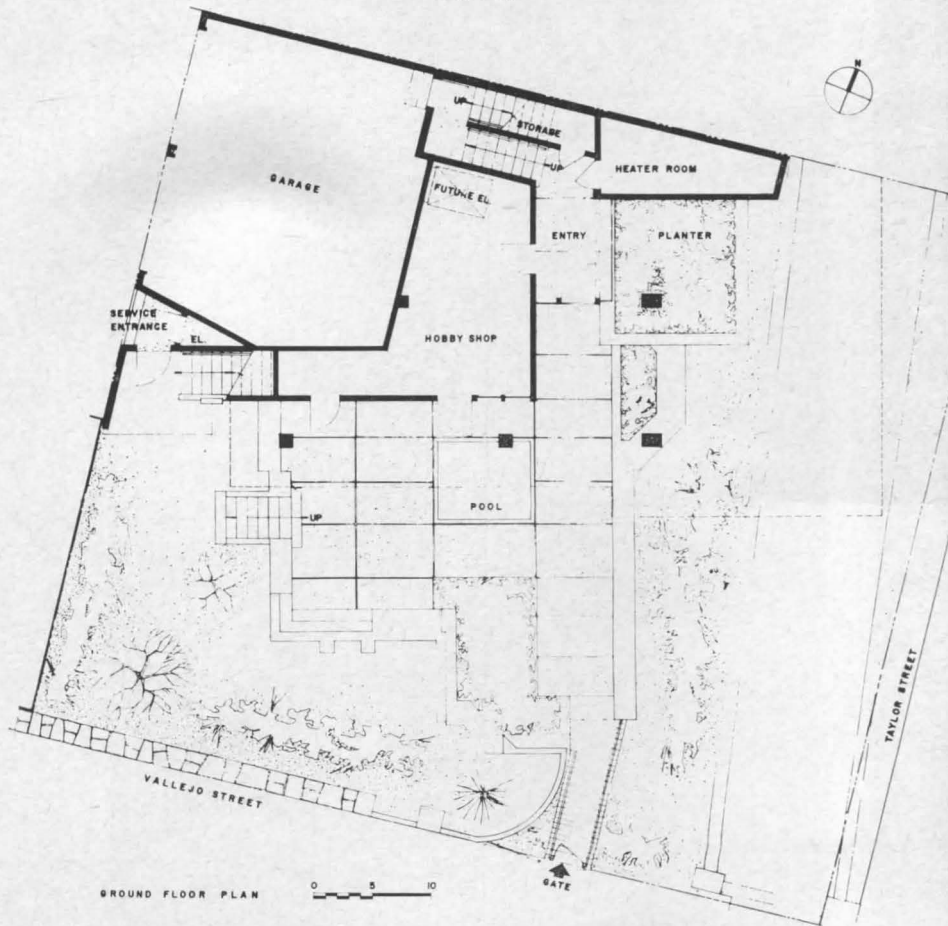
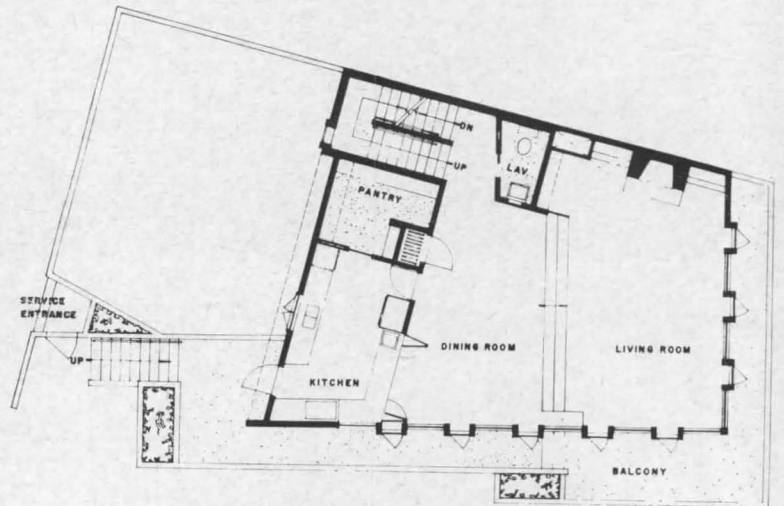
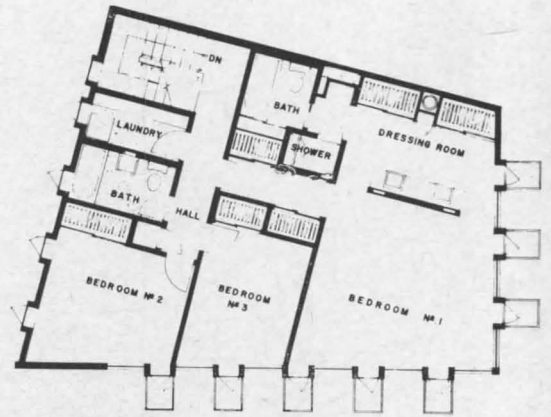

George Knight

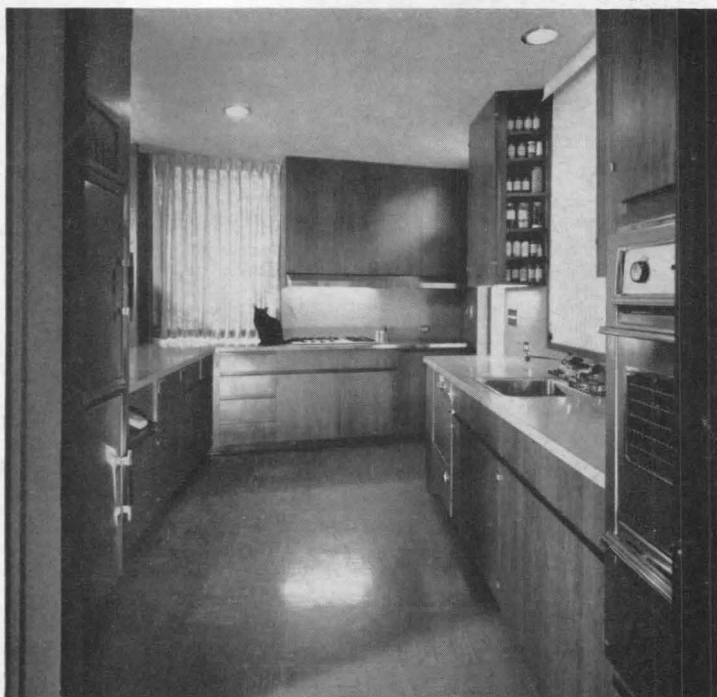

Town House in San Francisco

The kitchen (top photo) is fitted with walnut cabinets to match the living room paneling when folding doors are left open. The floor is vinyl tile, ceilings are plaster. Equipment includes built-in range, oven and refrigerator, stainless steel sink, garbage disposer and laminated plastic counters. The bathrooms (center photo) have ceramic tile floors and walls, hardboard ceilings. Counters are plastic, with built-in basins. Showers have thermostatic valves.

Bedrooms share the view through fixed glass panels (lower photo), flanked by doors opening on little balconies which punctuate the façade (curtains cover doors in photo)

HOSPITALS

With so much going on in architecture these days, particularly in hospital architecture, it is increasingly difficult for busy architects and engineers to keep up with the times. The hospitals in the pages following should help to remedy this. Each of the examples shown was chosen because it gives some indication of important trends in hospital design. Several have intensive care or other specialized types of nursing units. One illustrates the trend toward inclusion of psychiatric units in general hospitals. Another combines architecture for healing with architecture for teaching and research. Still others are examples of newer ways of planning for effective nursing, for efficient handling of supplies, for improved patient rooms. All of the hospitals reflect a trend toward recognition of the therapeutic value of good architecture. All are attempts to cause architecture to assume a positive role in the healing processes.

Things are happening in hospital architecture, and one of the reasons is the great number of serious and capable architects and engineers working in the field. Another important reason is that these professionals are participating in a great boom in hospital construction. This opportunity seems likely to continue for some time to come. It now appears that the current year will set a record for hospital construction of some 43 million sq ft of new construction at a cost of about \$982 million. This represents an increase, over 1960, of approximately 20 per cent in sq footage and 18 per-cent in dollar value. For 1962, F. W. Dodge Corporation economists are predicting another great year for hospital architects, with volume and dollar values closely approximating the 1961 totals.

BUILDING TYPES

® STUDY 301

Downstate Medical Center



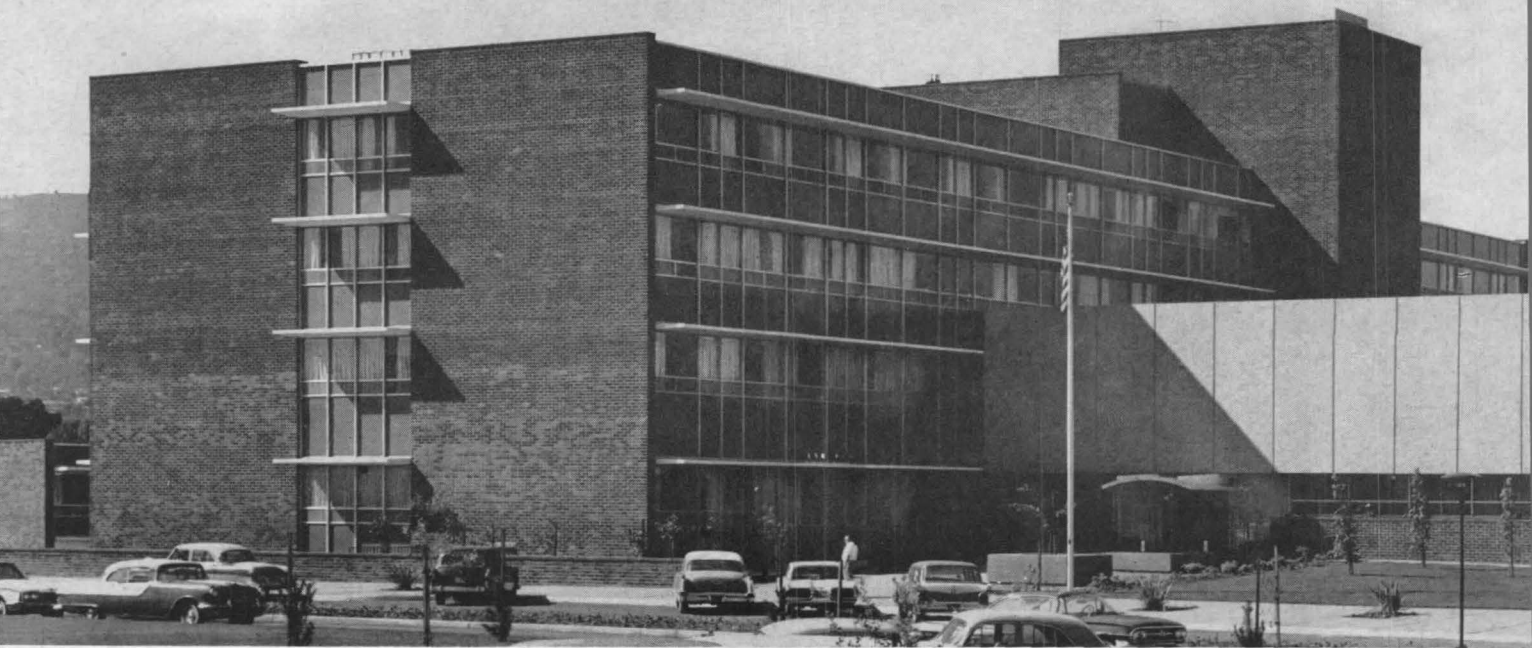

GENERAL CARE IMPROVED BY SPECIAL CARE UNITS

El Camino Hospital reflects the strong conviction of its architects that a hospital must not only function efficiently in all of its services but must also provide a pleasant environment for all who use it, from doctors and patients to kitchen staff. Its design accordingly gives equal emphasis to efficient circulation and clear-cut relationships between medical services, and to color, textures, and scale. Also an important factor in its design are the special patient facilities such as the intensive care unit, and its counterpart the pediatric special care unit, and the psychiatric unit for short-term care of acute psychiatric patients.

When it opened in September, the building provided 307 beds; when the fifth and sixth floors are added, the bed count will be raised to 450 and further expansion can be made by adding wings on the north and west. Space for expansion was provided but left unfinished in radiology and surgery areas.

El Camino's circulation system is based on a clear separation of the kinds of traffic it includes: supplies and food, received on the ground floor and processed there, are transported vertically to other floors without ever crossing the path of soiled or clean linen or other goods. Human traffic is also separated: visitors and ambulant patients use elevators which open into public corridors. Patients are conveyed from nursing floors to diagnostic and treatment areas by elevators opening into service corridors.

The psychiatric wing has a decidedly residential air with cheerful colors and easy indoor-outdoor relationships. Day rooms and the large outdoor activity area offer opportunities for group activities with relatively unobtrusive observation of patients.

NAME: *El Camino Hospital*

LOCATION: *Mountain View, California*

ARCHITECTS: *Stone, Marraccini & Patterson*
Norman W. Patterson, Partner-in-Charge
Dean L. Folker, Architect-in-Charge

STRUCTURAL ENGINEERS: *Smith & Moorehead*

MECHANICAL AND ELECTRICAL ENGINEERS:
Buonaccorsi & Murray

LANDSCAPE ARCHITECTS: *Osmundson & Staley*

CONTRACTOR: *Barrett Construction Company*

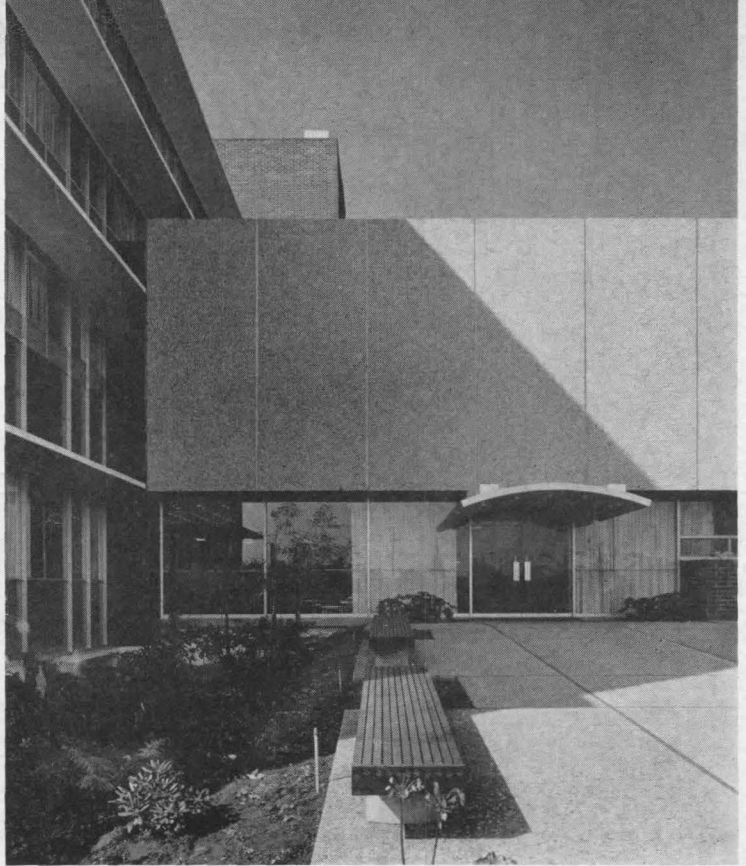

Karl Riek photos

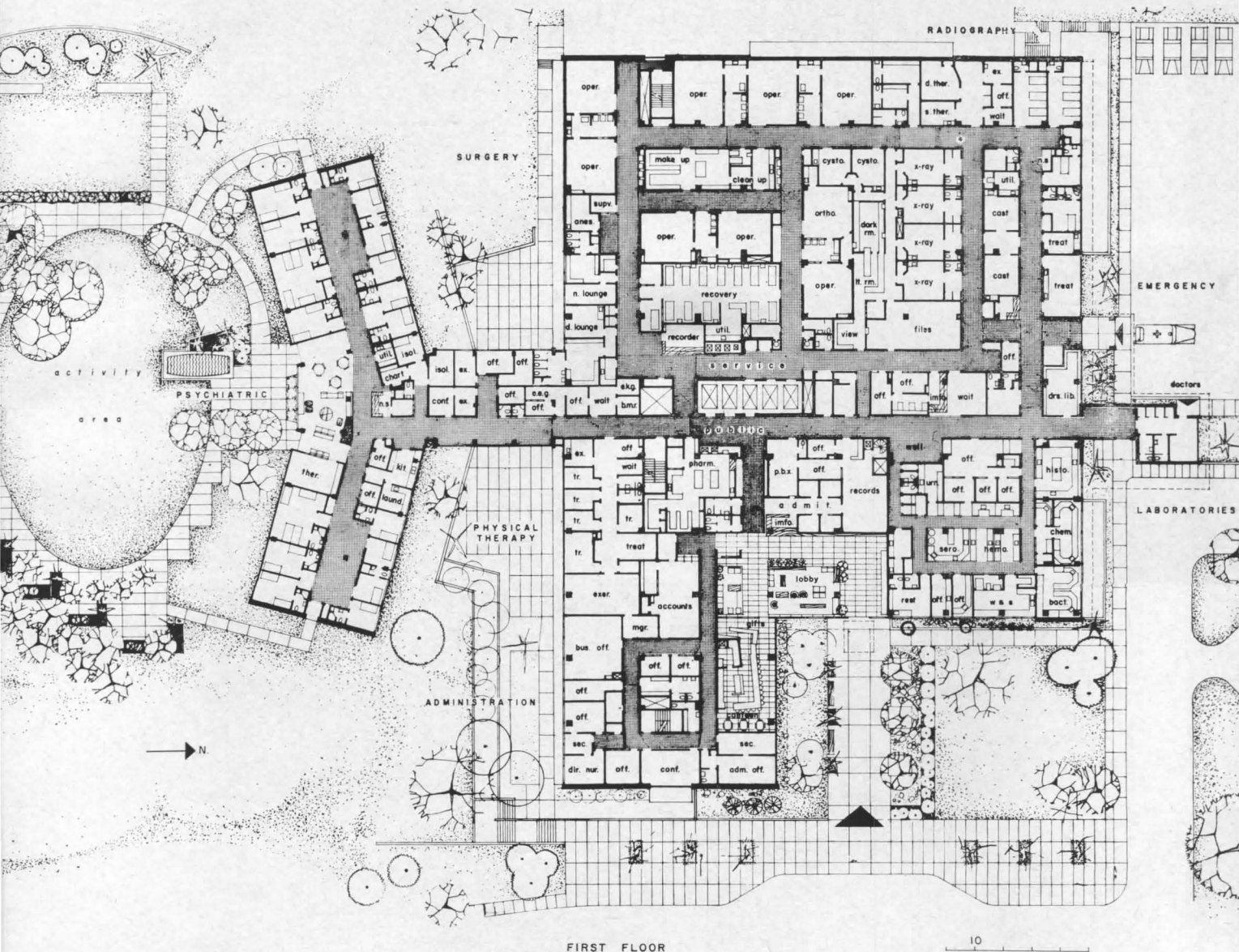

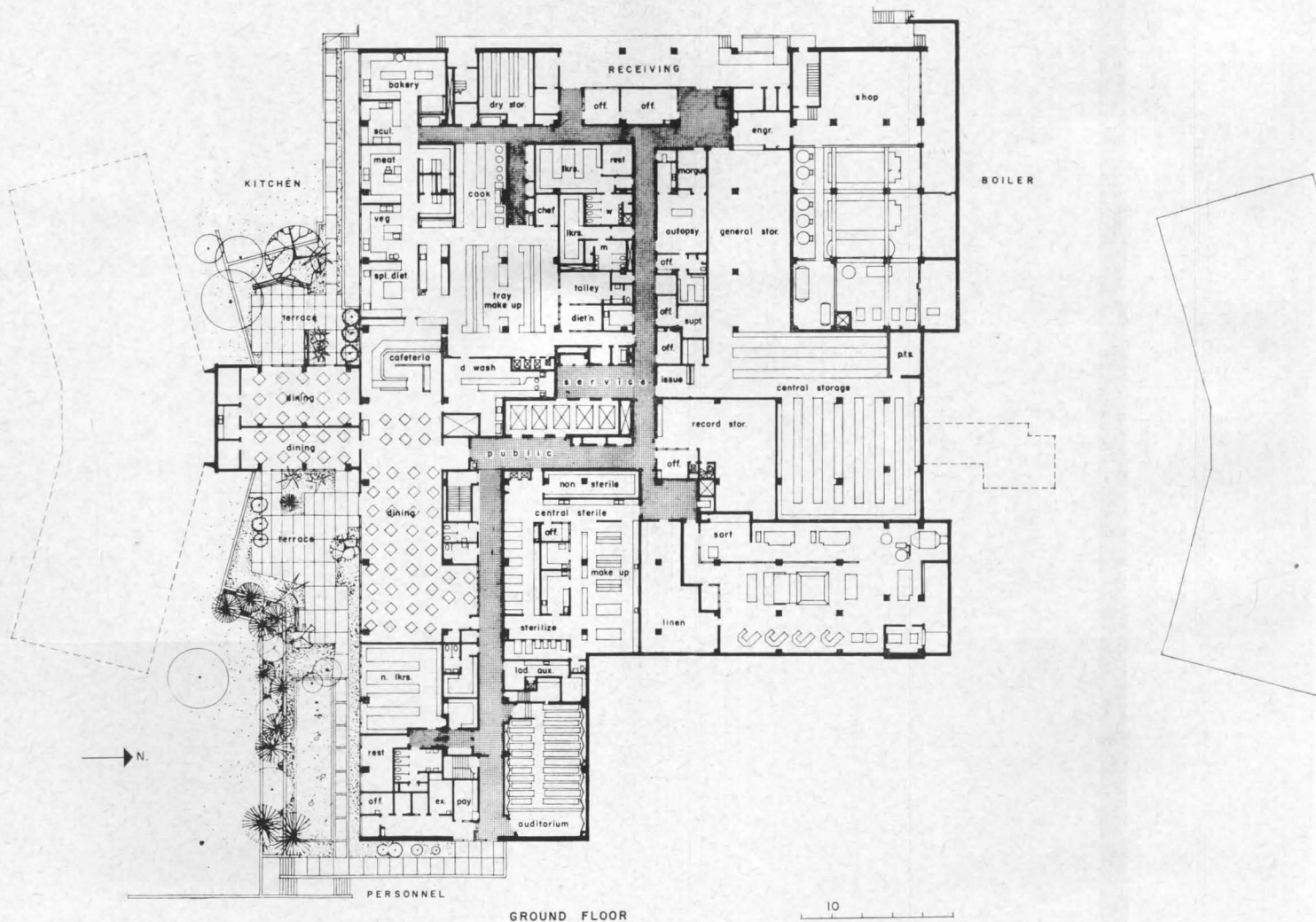
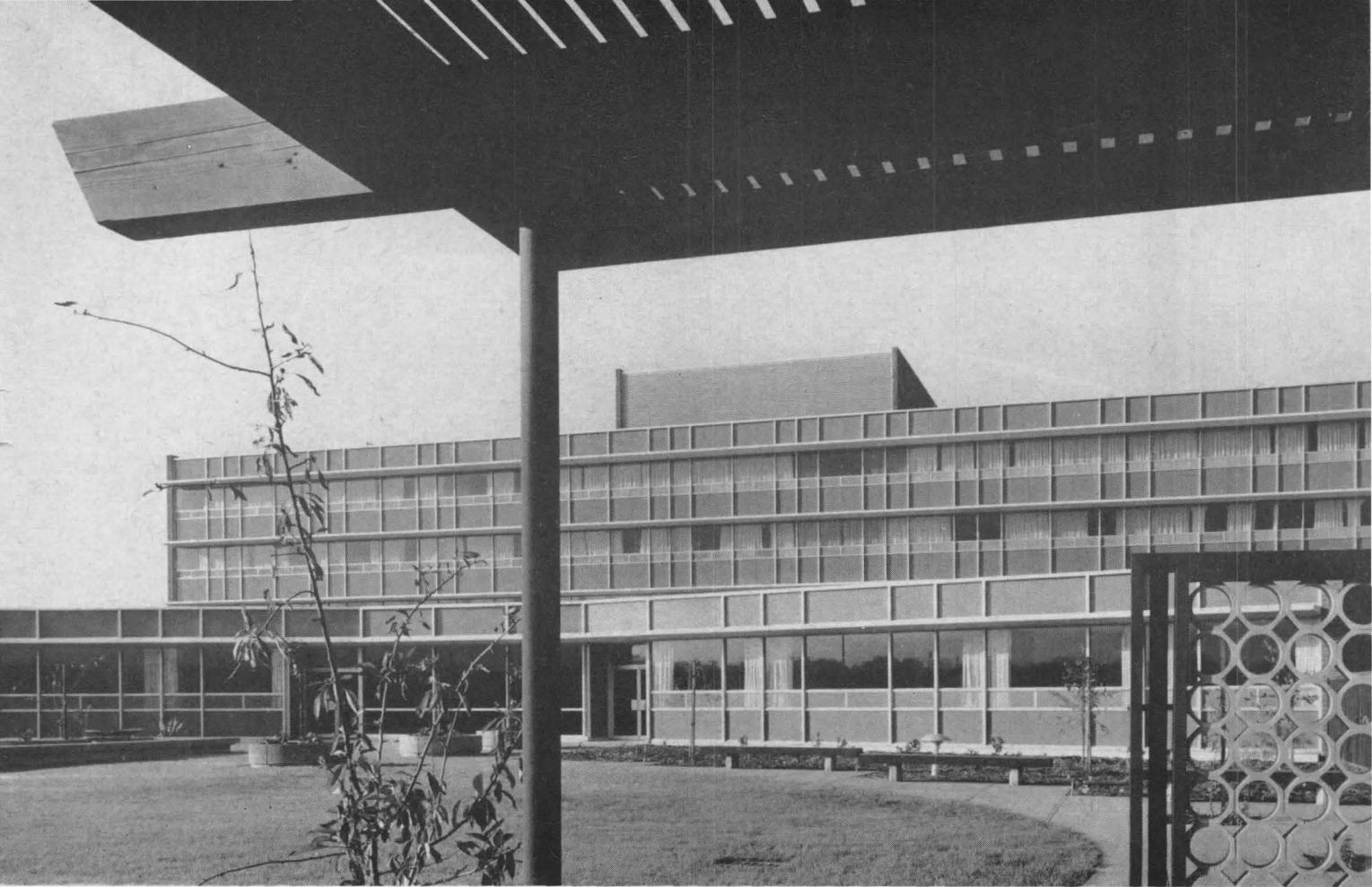

El Camino Hospital

Second, third and fourth floors are nursing floors, each with a specialized area in addition to typical medical and surgical wing. Second floor has obstetrical, maternity and nursery areas; third floor, pediatrics; fourth floor, intensive care. The difference in width between east and west wings on the third and fourth floors is explained by these specialized areas. All rooms have their own toilet facilities and so can be used for any level of intermediate or self-care. Each floor has a solarium for ambulant patient lounging.

Although the double corridors used on nursing floors require more floor area, their convenience in minimizing distance from nurses' station to patients' rooms was a compensating factor. Circulation in the obstetrical and nursery area is based on segregation of the nursery area but permits a close relationship between delivery rooms and facilities for special services for newborn babies.



Lobby



Meditation Room

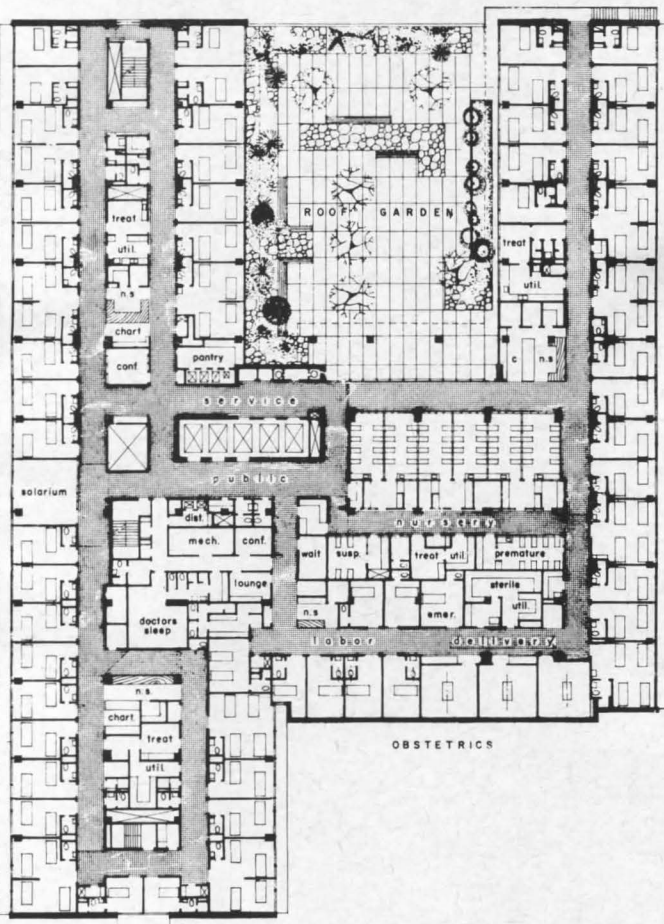

SECOND FLOOR

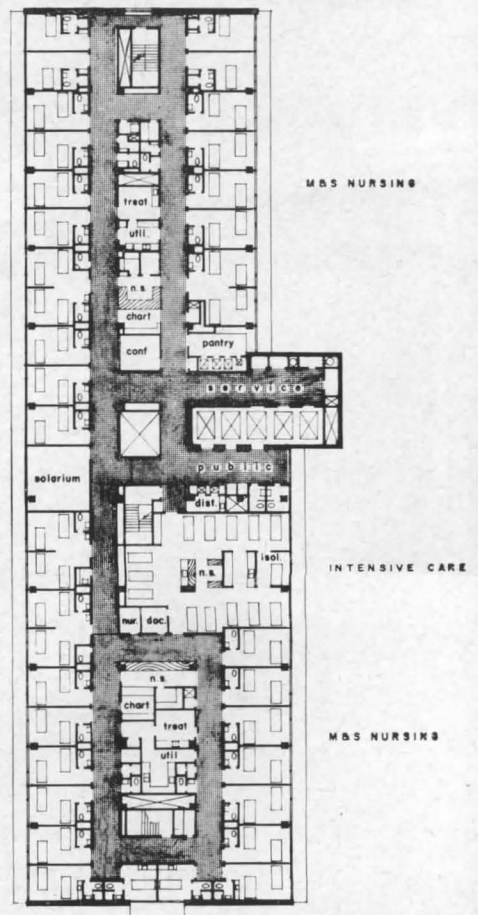

FOURTH FLOOR

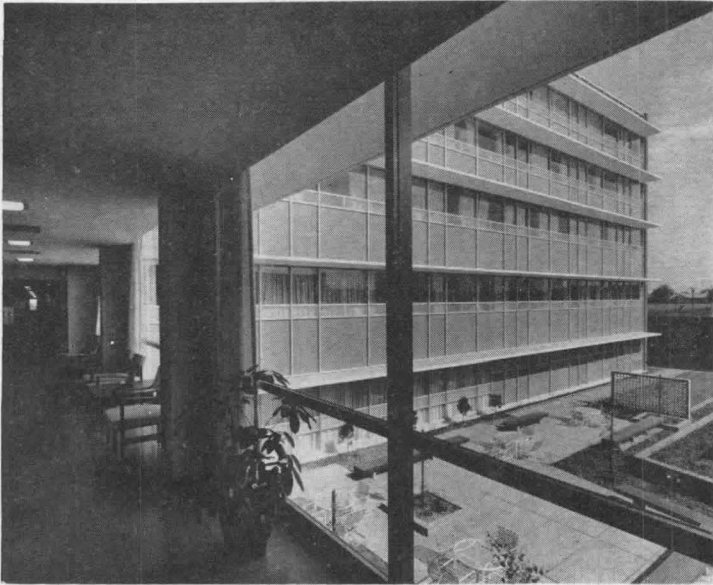

Dining Terrace From Corridor



Psychiatric Activity Court From Day Room

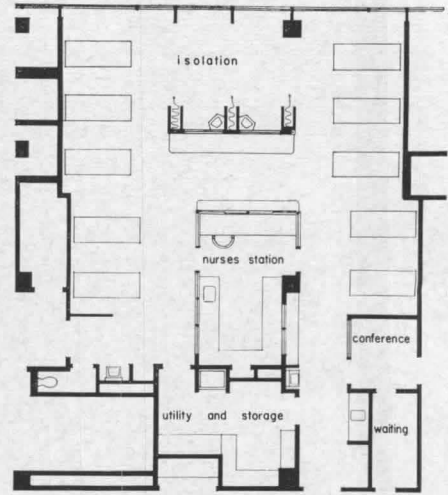

Intensive Care Unit Plan

The intensive care unit is shown in the plan above and the illustration below. On the fourth floor, it provides for complete and continual supervision of 14 beds, and is equipped with oxygen, suction, and other life-saving emergency equipment. Pediatrics special care unit on the third floor, although different in plan, permits the same kind of complete supervision of beds. In all patient areas, including intensive care, environment is as little institutional as possible: furnishings, colors, views out of rooms and views along corridors help to make a pleasantly human experience of patients' hospital sojourn



Nurses Station



Intensive Care Unit



Second Floor Roof Garden

El Camino Hospital

Nurses stations on each floor are located in the service core between the two corridors and open to them, permitting quick access to all rooms. Chart desk has specially designed rack which can be used from either side, avoiding possible conflict between doctors and nurses in using charts.

Rooms are designed so that bed locations can be staggered, permitting each occupant to have privacy (with curtains partially drawn) and at the same time a view out to the hills and pleasant surrounding country. Arrangement takes slightly more floor area but therapeutic value of view was considered to justify the additional floor area.

Nursery plan incorporates examining room so that doctors can examine babies without entering nursery; only nurses enter nursery. Viewing gallery is along corridor just inside roof deck

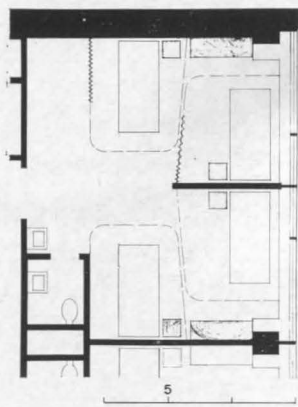

Typical Patient Room Plan

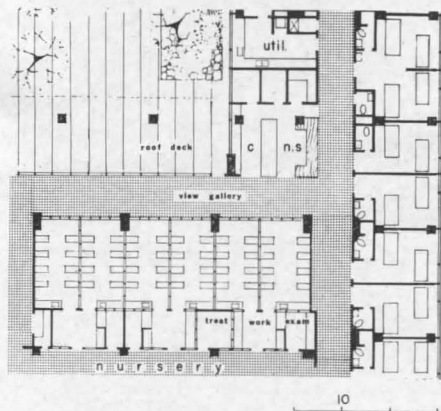

Nursery Plan



Typical Patient Room

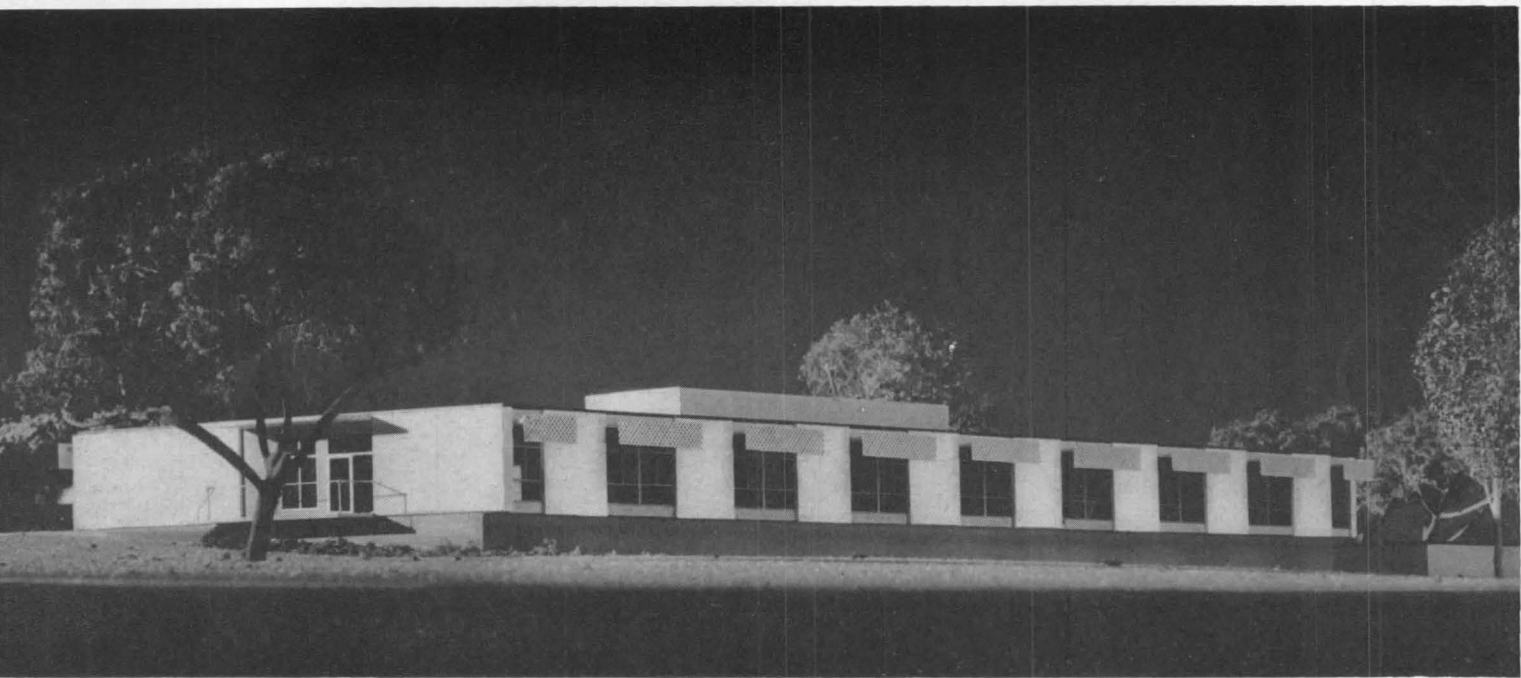

Gerald Ratto photos

NEW PATIENT ROOM PLAN FOR UTILITY, CONTROL

Roseville is a small 101 bed, community hospital, yet it has a number of unusual features in unusual combinations. The most immediately apparent difference between this hospital and many others is the layout of the patient rooms. By placing toilet rooms on the outside walls, the architects have been able to gain several advantages: space ordinarily wasted in vestibules has been used for patient sitting areas near the windows, nurses' steps are saved in caring for patients, and better control is gained through the wider view of the room from the corridor.

Another interesting feature of the hospital is the arrangement of the central service cores in the nursing units. All plumbing in the cores is placed along the long center partitions of the cores, for maximum utility at lowest costs. Also of interest is the small intensive care unit of five beds, provided at one end of the main floor general nursing unit.

The current Roseville project is an addition of 67 beds to an existing hospital of 34 beds. When completed, the new portion of the building will house all of the hospital facilities except administration and the maternity and pediatric departments which will remain in the older section. The complete hospital will contain 52,000 sq ft, of which 37,000 will be in the new wing. The cost of the new work is estimated at a total of approximately \$1.6 million, including equipment and fees. Construction is reinforced concrete frame, with precast exposed aggregate panels on exterior, aluminum windows, metal stud and plaster partitions, and fluorescent lighting. The building will be air conditioned.

NAME: *Roseville District Hospital*

LOCATION: *Roseville, California*

ARCHITECT: *Rex Whitaker Allen*

STRUCTURAL ENGINEER: *Haluk Akol*

MECHANICAL ENGINEERS: *Kasin, Guttman & Assoc.*

ELECTRICAL ENGINEER: *Mel Cammisa*

CONTRACTOR: *Campbell Construction Co.*



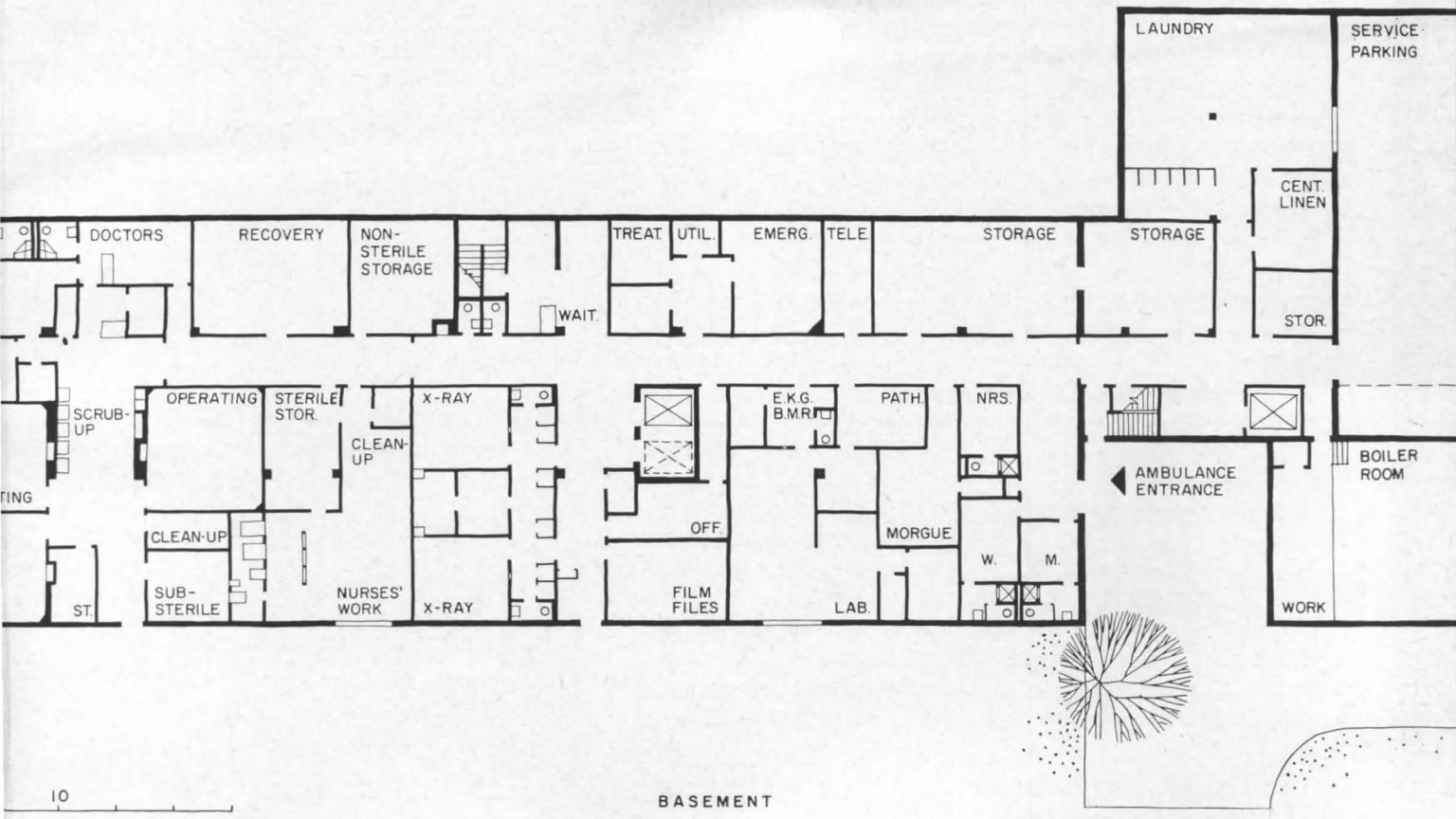
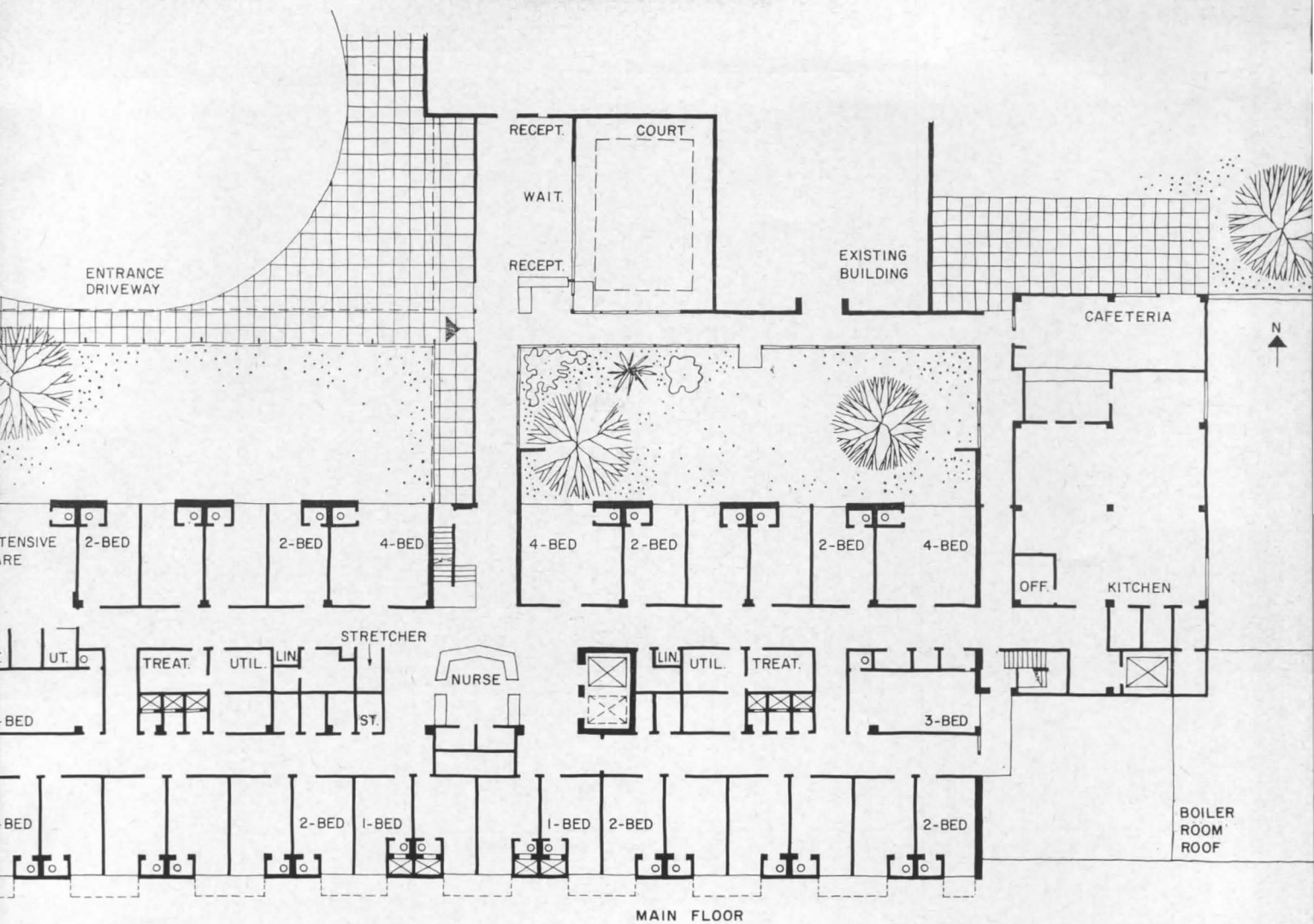

10



SERVICE CORE IS FOCUS FOR NURSING UNIT

This hospital, which will eventually have a maximum capacity of 238 beds, demonstrates some further developments of the outside toilet patient rooms and service cores used by the architects in other hospitals they have designed. The new project shown here replaces the facilities now occupied by the French Mutual Benevolent Society, an organization of about 8000 members which has operated hospitals for over 100 years in San Francisco.

In this project, the central service core is quite complete, and contains highly developed clean and soiled utility rooms, just behind the nurses station. The central service corridor permits service traffic within the unit to be completely separated from that of patients, medical staff, and visitors. By placing the service core in the central arm of the T-shaped plan, patient room corridors can be double-loaded, reducing steps and circulation confusion. Patient toilet rooms are on the outside wall, resulting in better use of space. In addition, each patient room will have a private, solarium-like, sitting area near the window and overlooking the gardens below.

This hospital will be constructed of reinforced concrete with floor to ceiling glass in patient rooms. Windows and decorative exterior panels will be of aluminum. The hospital will be built in several stages. Ultimately, it will contain 103,700 sq ft of space, and is estimated to cost \$3.25 million total.

NAME: *French Hospital*

LOCATION: *San Francisco, California*

ASSOCIATED ARCHITECTS: *Rex Whitaker Allen and John Carl Warnecke*

STRUCTURAL ENGINEERS: *Smith & Moorehead*

MECHANICAL & ELECTRICAL ENGINEERS: *Kasin, Guttman, and Malayan*

LANDSCAPE ARCHITECT: *Lawrence Halprin*

CONTRACTOR: *Swinerton & Walberg*

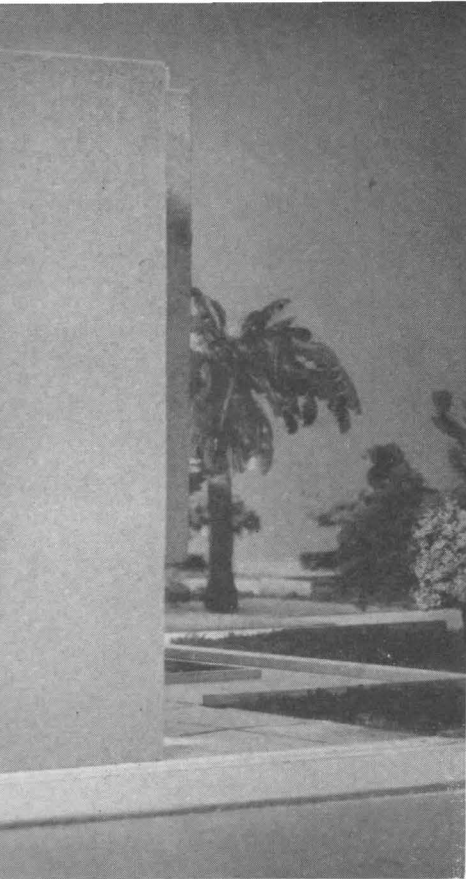

Gerald Ratto

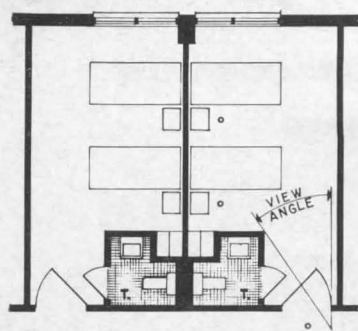

CONVENTIONAL
TOILETS ON CORRIDOR WALL

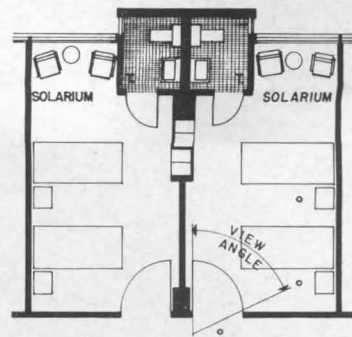

FRENCH HOSPITAL
TOILETS ON EXTERIOR WALL

| | | |
|----------------------|------------------------|----------------------|
| 220 ^{sq} ft | TOTAL AREA | 220 ^{sq} ft |
| 22 ^{sq} ft | TOILET AREA | 22 ^{sq} ft |
| 198 ^{sq} ft | NET AREA OF ROOM | 198 ^{sq} ft |
| 154 ^{sq} ft | CIRCULATION | 133 ^{sq} ft |
| 78% | PERCENT OF CIRCULATION | 67% |
| 15' | DISTANCE TO FIRST BED | 9' |
| 21' | DISTANCE TO SECOND BED | 15' |
| 36° | MAXIMUM VIEW ANGLE | 64° |
| 0 | AREA OF SOLARIUM | 30 ^{sq} ft |

* NURSES POSITION FOR MEASUREMENT OF DISTANCES TO BEDS

COMPARISON OF TYPICAL TWO BED ROOM

SCALE: 0 5 10

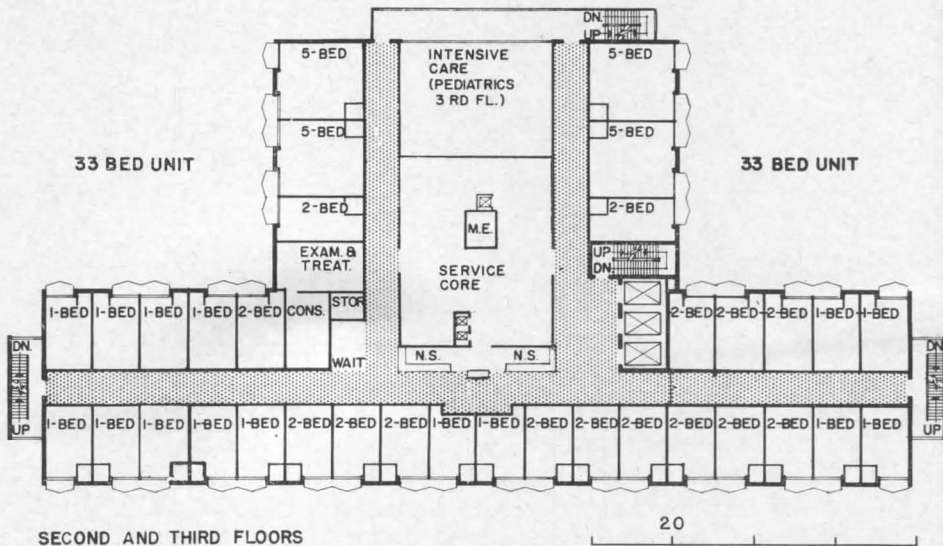

SECOND AND THIRD FLOORS

20

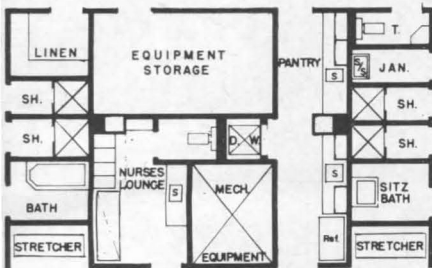

SERVICE CORRIDOR

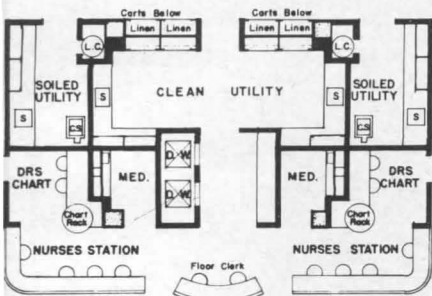

TYPICAL SERVICE CORE

10

Russell Leake





IMPROVED PATIENT CARE ON A SINGLE LEVEL

By utilizing the existing grades of the site, the architects of this little, 66 bed community hospital were able to place almost all of the patient services, including emergency, on one floor. As it turned out, it was possible, because of the grades, to give the emergency suite a second floor, ground level entrance at the rear, yet provide nearly all of the ground floor areas with windows.

Through close attention to the details of planning, the emergency, surgical, obstetrical, and x-ray departments were grouped together in one end of the building, around central sterile supply. Each of the departments is related to others important to its operation, yet none is incorrectly related, to any appreciable extent, to departments from which it should be separated. Nursing units are varied, some having double-loaded corridors, while others are adjacent to single-loaded corridors around a central nurses station. The net result of this is that a variety of nursing situations may be set up according to the amount of nursing care particular patients may need.

This hospital was planned for eventual expansion from the present 66 beds to a total of 110. All service facilities were planned for the final size of the building. The present structure contains 59,000 sq ft and cost approximately \$1.4 million, including equipment and fees. The building is of steel frame, with brick and aluminum-framed, porcelain enamel and glass curtain walls. Interior partitions are metal stud and plaster.

NAME: *Highland Hospital*

LOCATION: *Beacon, New York*

ARCHITECTS & ENGINEERS:
Cannon, Thiele, Betz & Cannon

ELECTRICAL CONSULTANTS:
Walter Sherry & Assoc.

CONTRACTOR: *Chiappinelli-Marx, Inc.*

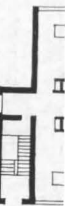

FIRST F

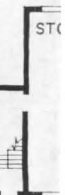

GROUND



Leop Zelones photos

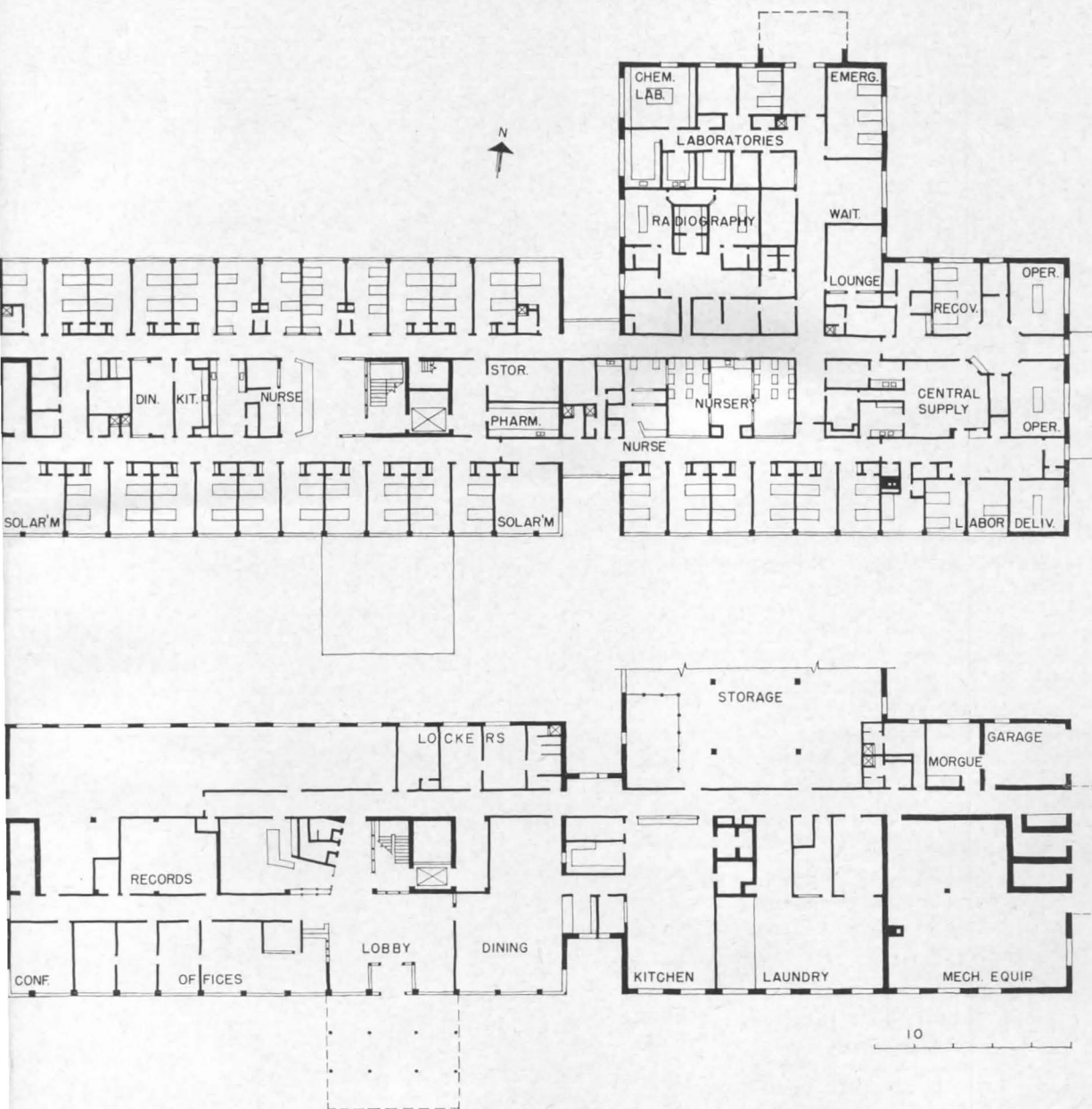



Lobby



Central Nurses Station

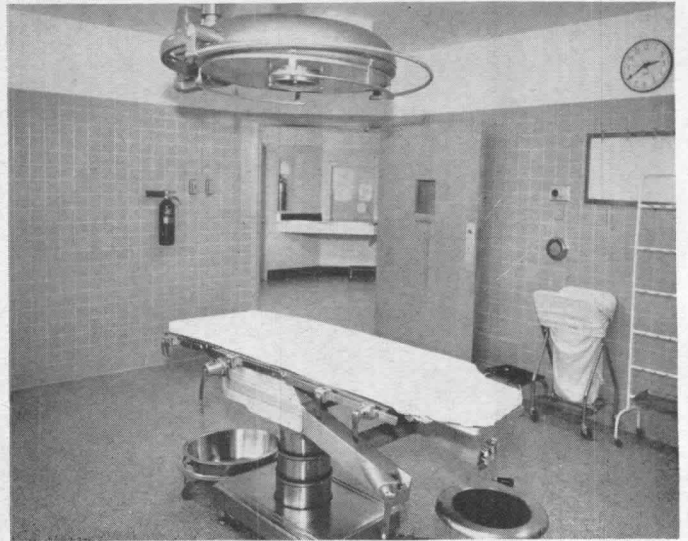

Operating Room

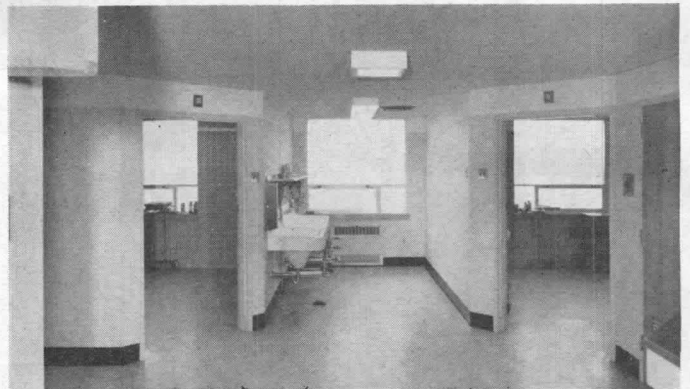

Operating Suite Vestibule



Central Sterile Supply

Highland Hospital

Lobby: located on the ground floor, the lobby permits patient and visitor entry to second floor via stairs shown in the background. The service entrance is also on the ground level, at the end of the building. Because of the sloping site, the emergency and doctors entrance opens on grade at the rear of the building on the second floor.

Nurses Station: the main nurses station shown is centrally located between two nursing unit corridors. It affords good control of patients, services, and visitors. A small dining room and kitchen, just behind the nurses station, is used for ambulatory patients' meals. Bed patients meals are prepared in the main kitchen on the ground floor.

Operating Rooms: two operating rooms and a recovery room are provided in the surgical suite. These are grouped around central sterile supply and are so placed that space is provided between them for washup. Close by, but separated from surgery, are the x-ray suite, the laboratories, the emergency suite and the waiting room.

Central Sterile Supply: placed between the surgical and obstetrical suites, the surgical supply area is so arranged that supplies can be delivered directly to either of the other suites, quickly and efficiently



Wolfgang Stevers photos

SIMPLIFIED PLAN FOR ECONOMY AND EFFICIENCY

NAME: *St. Frances Xavier Cabrini Hospital*

LOCATION: *Melbourne, Australia*

ARCHITECTS: *Stephenson & Turner*

This general hospital is owned and operated by the Missionary Sisters of the Sacred Heart. The plan is straightforward, efficient, and comfortable. It stems from a few major concepts carried out in good form. All services, including tray service for food, are centralized. Nursing units are on a simple, double-loaded corridor plan, with toilet and bedpan washing facilities for each patient room. Nurses stations have service core facilities adjacent. These concepts have been expressed in their simplest terms to produce a hospital that functions well.



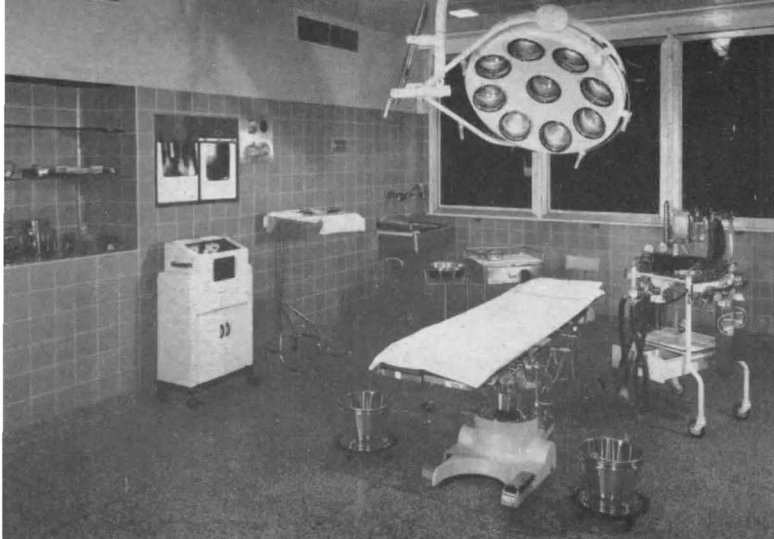

Operating Room



Laboratory



Nursery



Nurses Station

The design of this 137 bed hospital in Australia is basically L-shaped with nursing units in the long arm and major services such as surgery, emergency, and obstetrics in the shorter arm. With this scheme, it was possible to stack all of the areas that require particular types of mechanical and electrical equipment, thus simplifying placement of vertical chases. Since the nursing units are not air conditioned, but the other areas are, the mechanical equipment room was placed on the top floor directly over the areas it serves, thus simplifying duct runs and lowering costs.

The structure of the hospital is reinforced concrete frame on spread concrete footings directly below the basement floor slab. Floor construction consists of continuous flat concrete slabs with hollow block infilling. By introducing horizontal ducts at the junction of floors and columns, the placement of vertical ducts was facilitated. The architects found that this structural system reduced the cubic contents of the building and enabled them to place ducts and piping at each floor level with ease and economy. Exterior walls are brick; interior partitions are lightweight concrete block, mostly plastered and painted. The approximately 91,000 sq ft of the present building cost the equivalent of about \$1.8 million, including architects' fees. An addition has been planned for 75 beds.

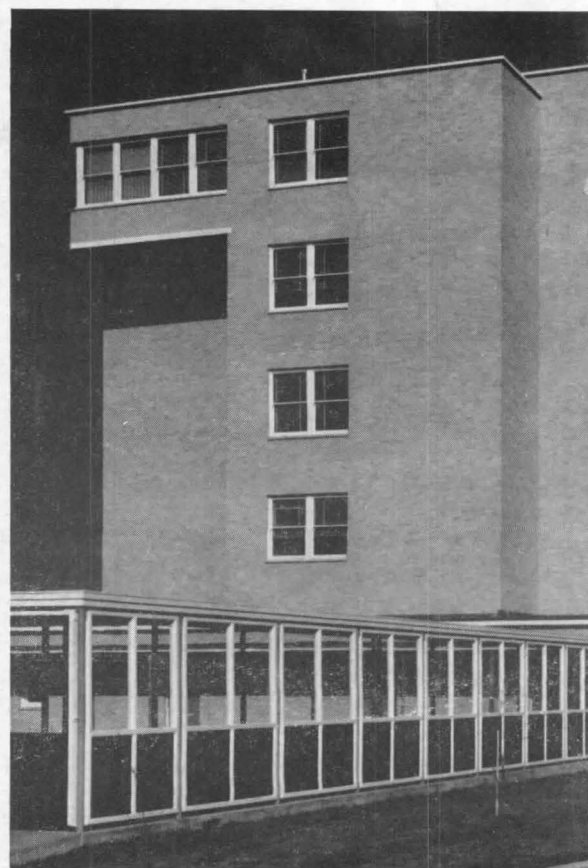

St. Frances Xavier
Cabrini Hospital

The main floor of this hospital is mainly devoted to administration, emergency suite, and the chapel. Radiology is made part of the emergency area. The kitchen, central sterile supply, laundry, and pharmacy are located in the basement. The supply room and pharmacy are directly connected with nursing stations above by dumbwaiters. Also in the nursing stations are laundry chutes to basement and food service lifts.

The food preparation, serving, and dishwashing cycles were closely studied and provisions made for efficient handling. Similarly, flow diagrams were made of the laundry and supply cycles, and these services planned into the hospital for efficiency and saving of time.

Nurses stations are provided with central linen storage rooms, janitors closets, and pantries with refrigerators. All three operating rooms are served by one sterilizing room, in order to gain economies in construction and better control

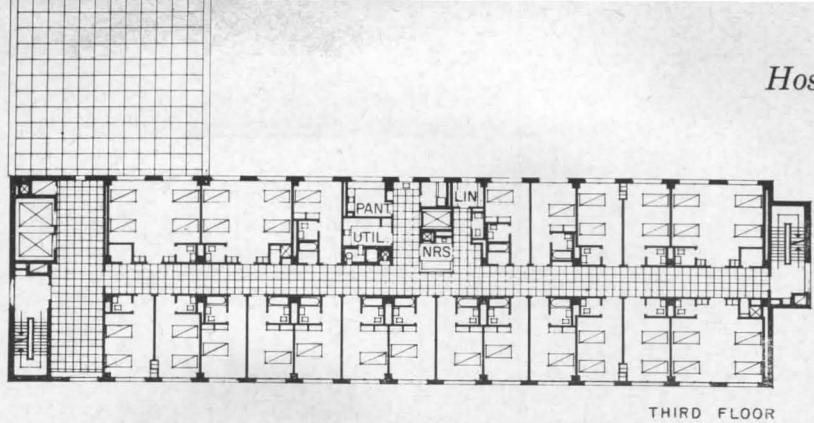

THIRD FLOOR

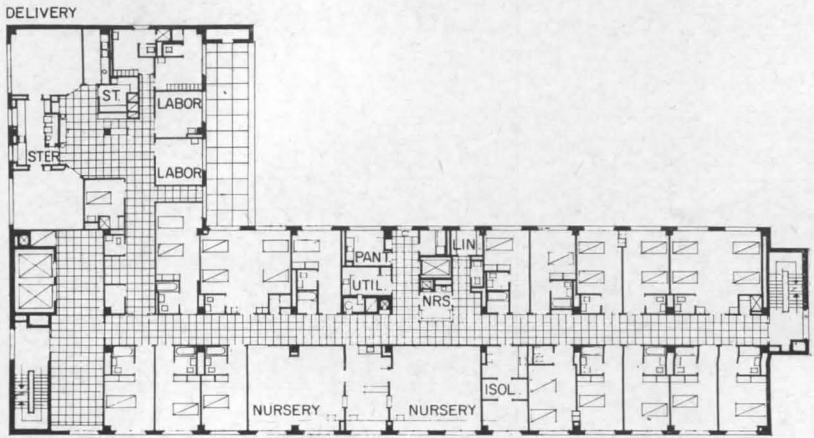

SECOND FLOOR

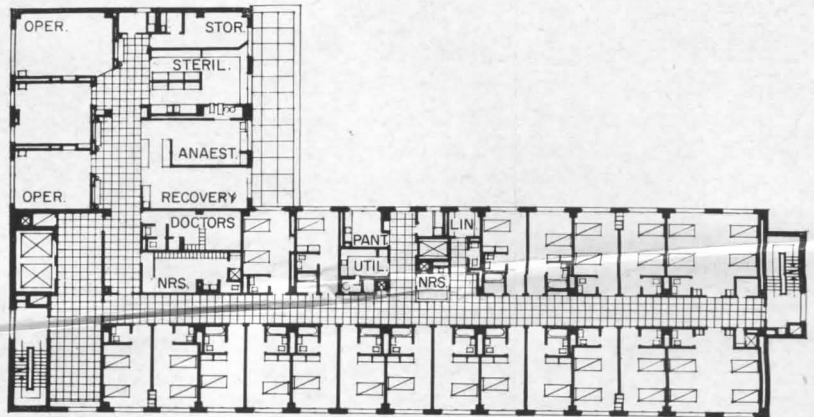

FIRST FLOOR

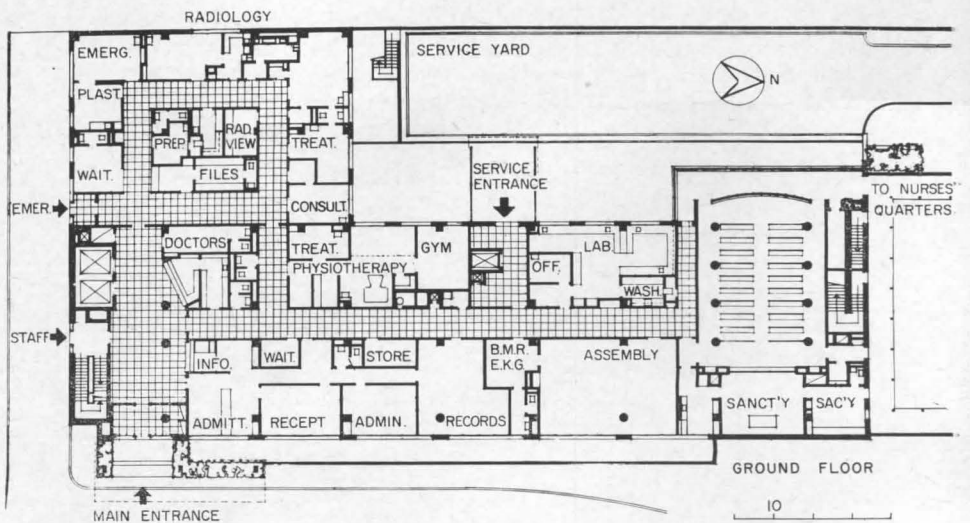

GROUND FLOOR



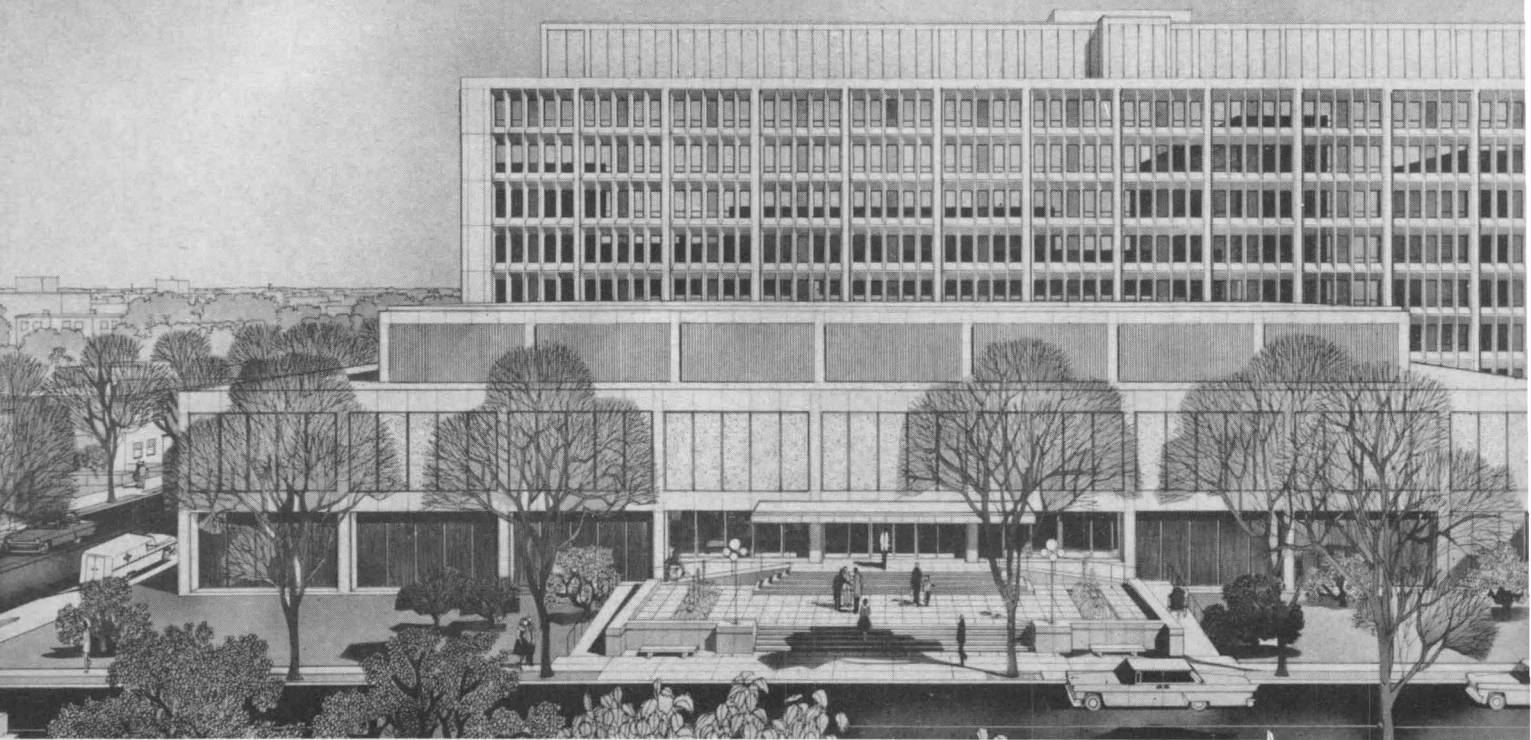

HOSPITAL FOR HEALING, TEACHING, AND RESEARCH

The combination of good architecture with the solutions of the complex problems of a teaching hospital resulted in this design for the Downstate Medical Center. In this building, the architects have attempted, with considerable success, to interweave architecture for healing with architecture for learning and for clinical research. The building, along with the existing basic sciences building to which it will be attached, will eventually provide facilities for 350 bed-patients, approximately 110,000 out-patient visits a year, and for an enrollment of 800 medical students.

The basic scheme of the building is an eight-story hospital tower, with clinical research facilities in one end and in a wing connecting the tower to the basic science building. Research activities are, for the most part, located on the nursing floors to which they relate, medical research on the medical nursing unit floor, surgical research on the surgical nursing floor. The architects feel that a better solution would have been a similar floor plan with all hospital facilities in one wing, all research in the other, but the limits of the site prevented this kind of solution.

The new building will contain approximately 600,000 sq ft and its estimated cost is \$20 million. About one fourth of the floor area will be research. Nursing units will have 20 beds and there will be four units per floor. The nursing team for each unit will consist of one registered nurse and two nurses aides or student nurses. Exterior walls will be precast concrete with exposed marble aggregate. Windows will have low, 9 in. stools, to facilitate the bed-patients' views.

NAME: *Downstate Medical Center*

LOCATION: *Brooklyn, New York*

ARCHITECTS: *Urbahn, Brayton and Burrows*



Rendering by Helmut Jacoby

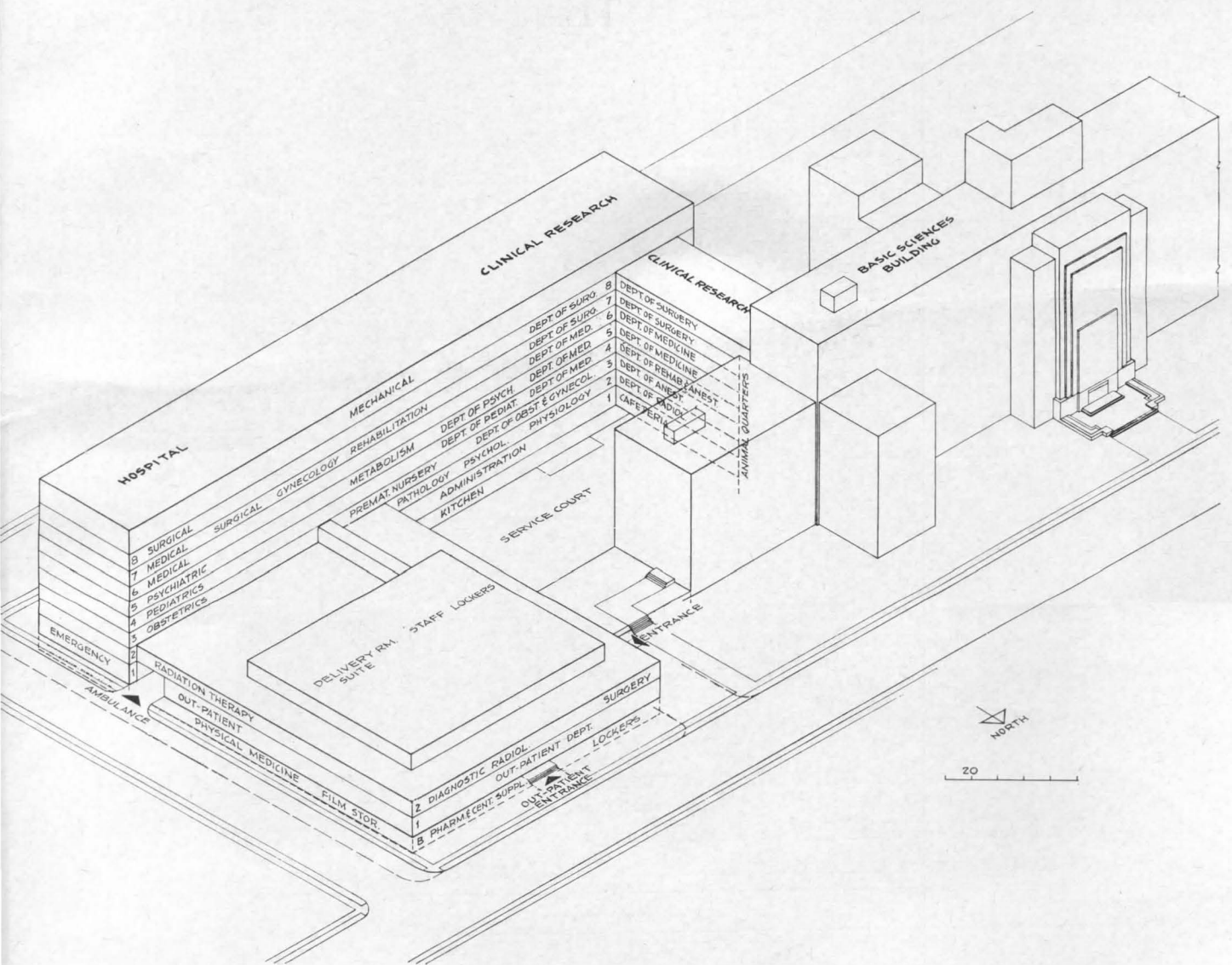

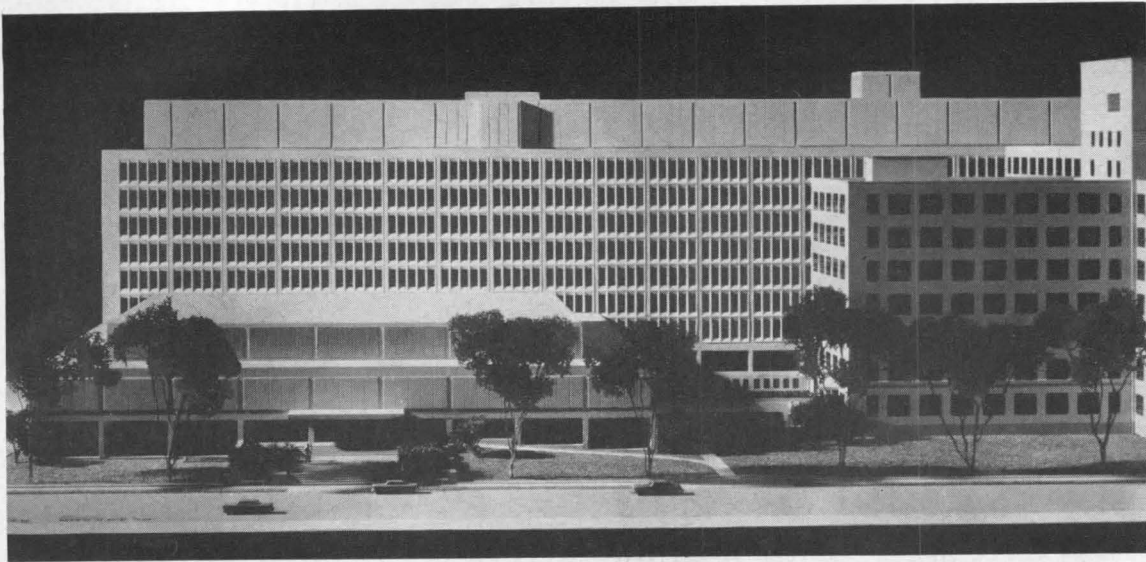

Downstate Medical Center

The typical floor plan indicates the relationships between the research facilities, the basic sciences building, and the nursing units. Most floors are similar, but in some instances such close relationships were not necessary.

In order to reduce the chances of spreading staph infections in the maternity unit, a basic scheme of units of two two-bed patient rooms with nurseries for four bassinets was developed. Each unit has its own work room and nurse. In case of infection, a single four bed unit may be isolated, and after discharge of mothers and babies, may be disinfected without disturbing the operation of other units on the obstetrical floor.

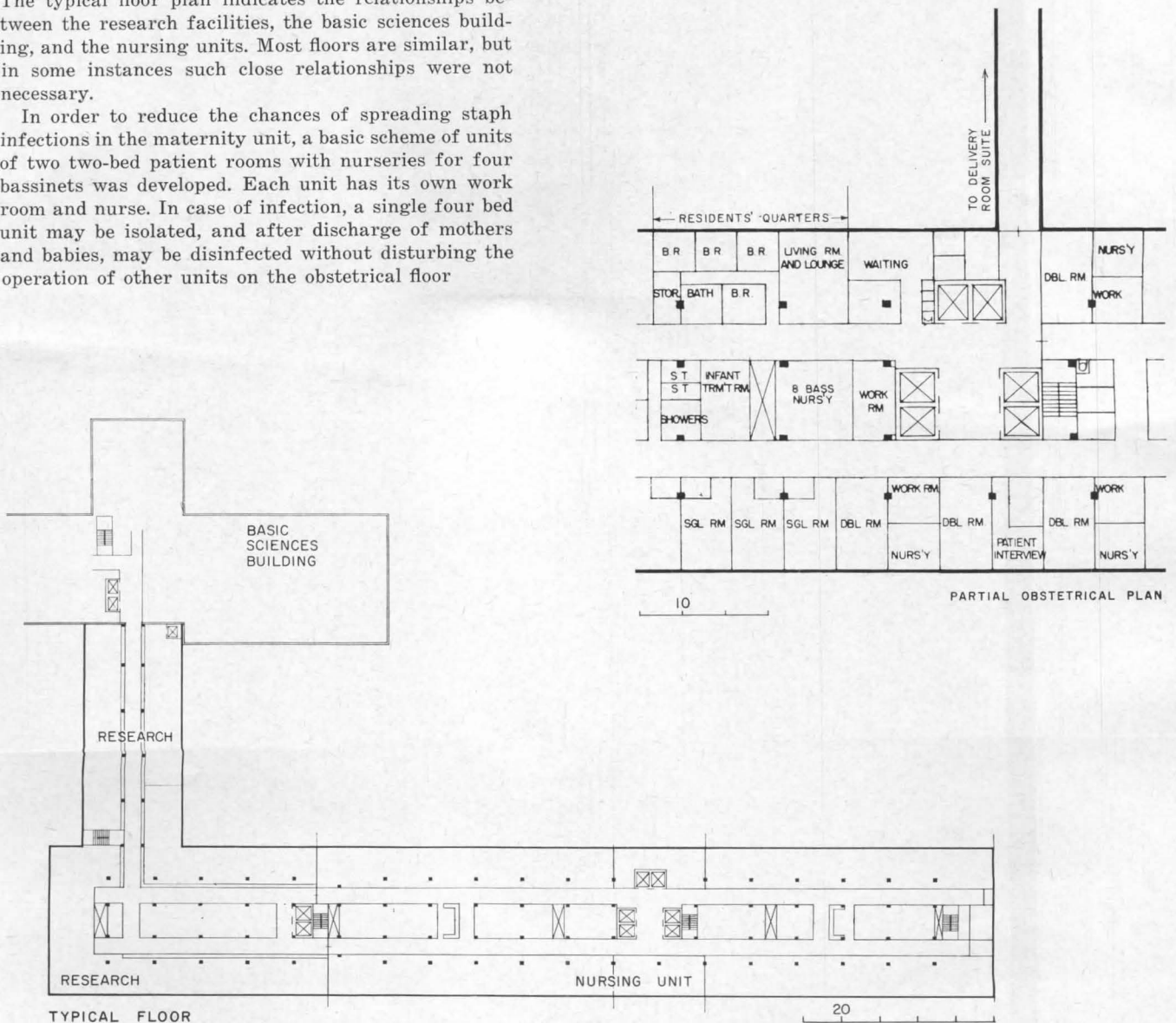

Architectural Engineering

Model Tests for Complex Structures

Mathematical analysis of complicated and unusual structural shapes can be exceedingly tedious and time consuming. With shells, space frames and all their cousins being very much in demand today, engineers are looking for ways to make model analysis more practical and meaningful in determining deflections and stresses. Although models still exist of some of the great Renaissance buildings, chances are that their many purposes was to aid builders in devising means for constructing the structures.

A short history of model analysis and the development of present methods are presented in a paper by Henry J. Cowan, Professor of Architectural Science, University of Sidney, in the proceedings of the 1961 Australian Building Research Congress. Cowan points out that 40 years ago a method was developed by George E. Beggs in which minute deflections of models under load were measured by microscope—a rather laborious procedure. Models have been used much more often, Cowan observes, in the design of dams, where construction costs are far higher than for buildings, and in the design of aircraft structures, where savings in weight have been essential. Countries having facilities for model testing include Italy (Nervi tested a model as early as 1935), Portugal, Spain, France, England and Russia. Currently there is interest in the United States at several of the larger engineering schools. Cowan's paper briefly describes model investigations done in his laboratory on a reinforced concrete folded plate dome and on a 36-story steel frame in which wind load was particularly important. Example of a U. S. model test is discussed on p. 152.

Less Theory, More Experiments

A growing dependence upon mathematics and theoretical methods as sole solutions to complex engineering problems has come under fire by Dr. Max M. Frocht, professor of mechanics and director of experimental stress analysis at the Illinois Institute of Technology. When the shape of an element and the load upon it are complicated, theoretical methods alone are not sufficient for analysis, according to Dr. Frocht, and recourse must be made to experimental methods. Nowadays, he says, it is much easier to find well prepared theoretical analysts than competent experimentalists.

A Report on Canadian Building Research

Building Research 1960 is the first of a series of annual reports upon the work of the Division of Building Research of the National Research Council of Canada. A major activity last year, described in the report by Robert F. Leggett, Director, was revision of the National Building Code of Canada which was first published in 1941, and first completely revised in 1953. About half of the urban population of Canada lives in municipalities that use one of the earlier editions of the code in some way. Announced also in this report is the start of a new service, Canadian Building Abstracts which is a part of a slowly but steadily developing international building abstract project stimulated by the International Council for Building Research, Studies and Documentation (CIB).

New Directions in Power Generation

"It is entirely conceivable that there will be a period in our future when central power stations will give way to individual fuel cells in every home," said James D. Flynn of the Cincinnati Gas & Electric Company at a symposium on fuel cell developments and applications during the Fall General Meeting of the American Institute of Electrical Engineers. The fuel cell has no moving parts since chemical energy of a fuel is converted directly into electrical energy. If current interest in their research is maintained, it is likely that fuel cells will serve as power sources in special applications within the next five years, Flynn averred.

This Month's AE Section

INTEGRATING MECHANICAL SYSTEMS: A DESIGN APPROACH, p. 148. *MODEL TEST PREDICT SPACE FRAME BEHAVIOR*, p. 152. *TIME-SAVER STANDARDS: Floor Framing*, p. 155. *BUILDING COMPONENTS: Sound Systems*, p. 161. *Products*, p. 163, *Literature*, p. 164.

INTEGRATING MECHANICAL SYSTEMS:

A Design Approach

The author gives a procedure for better relating mechanical-lighting-structural systems, describes an experiment using radiant cooling for more efficient pick-up of heat from lighting, and gives a method for quick calculations in mechanical design.

Architectural and engineering design factors must be related quantitatively to provide a proper frame of reference for intelligent decision making. The occupancy requirements created by the modern office building, the research laboratory, the hospital, the multi-purpose school—each with specific requirements for air conditioning, modular flexibility, higher lighting levels, etc.—demand more space planning and evaluation of building systems and products than ever before.

With a wider choice of new materials and products, the architect finds design decision making more complex. To state the problem another way, the architect must find a basis of relating the practical significance of architectural design factors as they effect the selection of components and systems by the mechanical, electrical, and structural engineers and vice-versa. The variables of one technology must be related with variables of all associated technologies before economic criteria for decision making can be applied.

Prior to completion of a building design in which integration of building systems is to have some significance, two conditions must be satisfied:

1. All the design variables must be properly related.
2. The interacting system energies must be evaluated.

The following outline is presented to indicate the sequence of steps that the architect should take with his engineers to successfully integrate a building design:

1. Ascertain the function which the occupant—building combination is to perform.
2. Determine the requirements and restriction to which the design must conform.
3. Determine the conditions under which the occupant—building combination must operate.
4. Determine the characteristics of the necessary systems which may

be a part of the building.

5. Block out alternate systems which will perform the required job.
6. Within each of the proposed designs, examine the appropriateness of selected components in terms of:
 - a. Functional character.
 - b. Compatability with design restrictions.
 - c. Reliability under expected operating conditions.
7. Select the most promising design and proceed with preparation of detailed drawings and specifications.
8. Design necessary system components and means of controlling operating conditions arising as a result of the total building design selected.
9. Refine the total designs in terms of:
 - a. Economy of construction.
 - b. Efficiency of operation.
 - c. Ease of maintenance.

SYSTEMS DESIGN TECHNIQUE: An example

The use of the systems approach as a practical architectural and engi-

neering design technique will lead to a significant contribution toward achieving the total integration of environment with structure. The interaction of building systems requires that successful building ceiling and floor products, which serve as components of building systems, be designed and developed as a function of systems design.

The panel air system illustrated in this article is an example of how structural, mechanical and electrical components can be integrated. It is a split air-water system which removes the heat load from the conditioned space by radiant and convective cooling. Humidity is removed independently by chemically dehumidifying outside air. The system consists of a radiant ceiling located in interior and perimeter spaces and a completely unzoned air distribution system operation at air calculation rates of approximately four air changes per hour.

The panel air system utilizes cellular floor as an integral component of the mechanical-structural-electrical and lighting system. As a structural member, cellular air floor is a

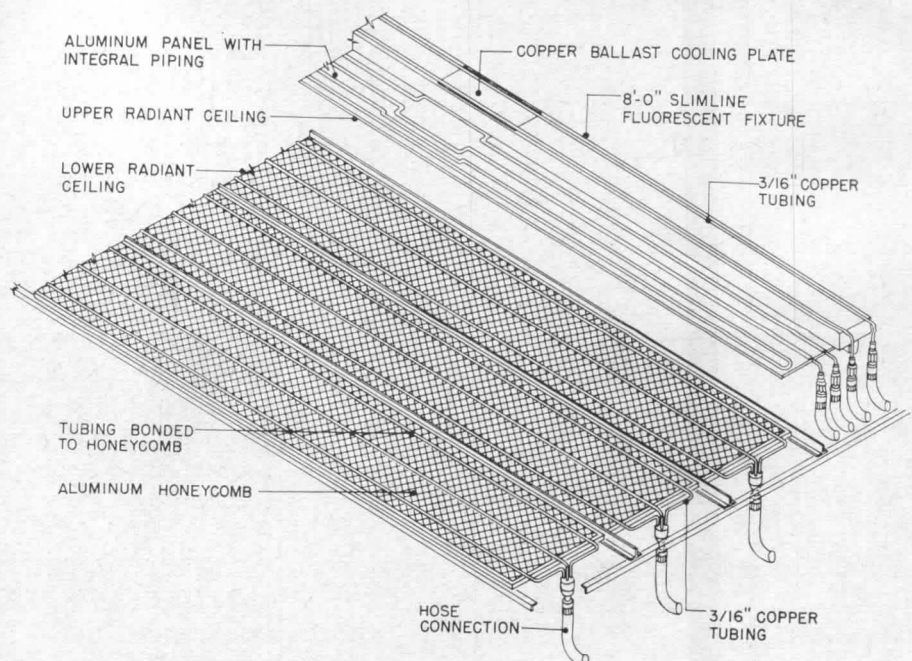

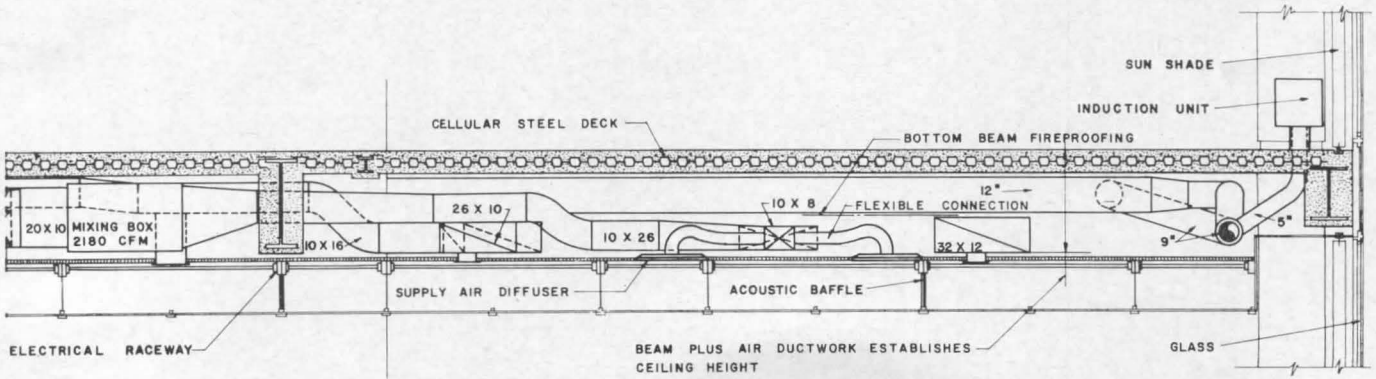
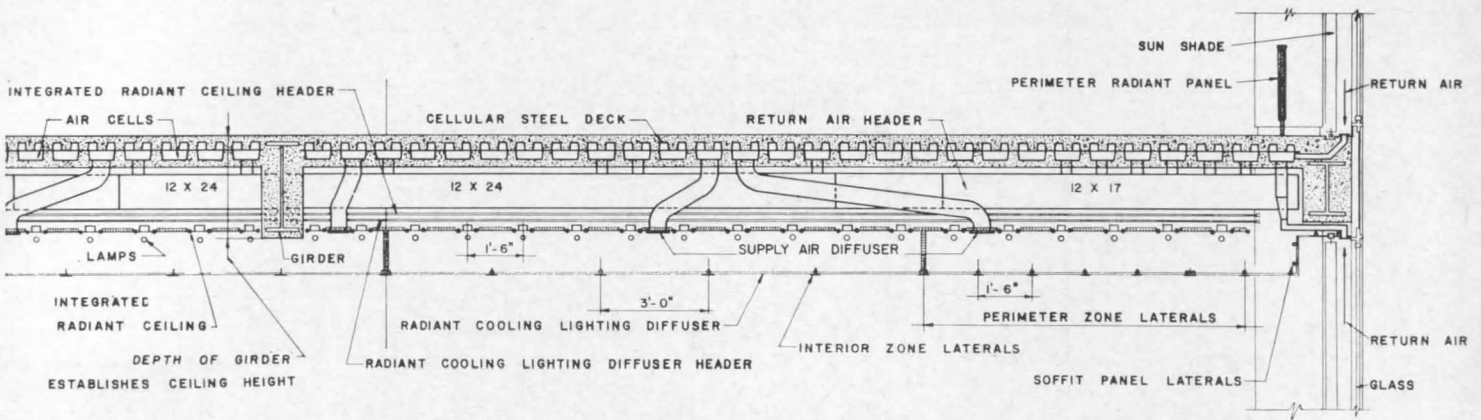

RADIANT COOLING SYSTEM COMPARED WITH CONVENTIONAL DESIGN

Drawing at the top illustrates the components of an integrated radiant panel—air system. Radiant cooling panels in the vicinity of the fluorescent lamps pick up heat from the lamps directed upward; radiant heat from the lamps directed downward is captured by the radiant cooling lighting diffuser. The result is that only minimal ductwork is required as compared with a conventional system shown in the lower drawing. Depth of the floor-ceiling system in the radiant panel—air system is governed by the depth of the girder. In the conventional design, sufficient space must be provided for fitting in the various duct systems

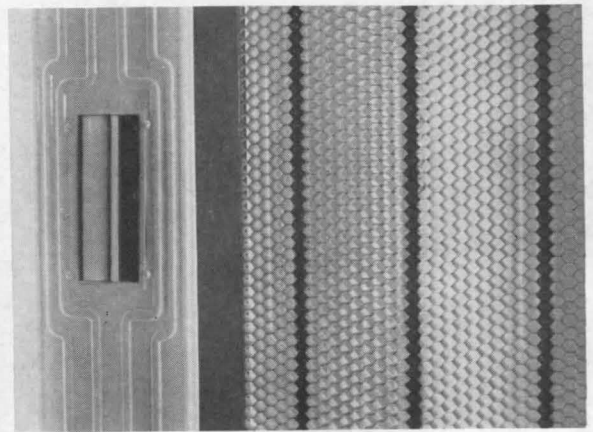
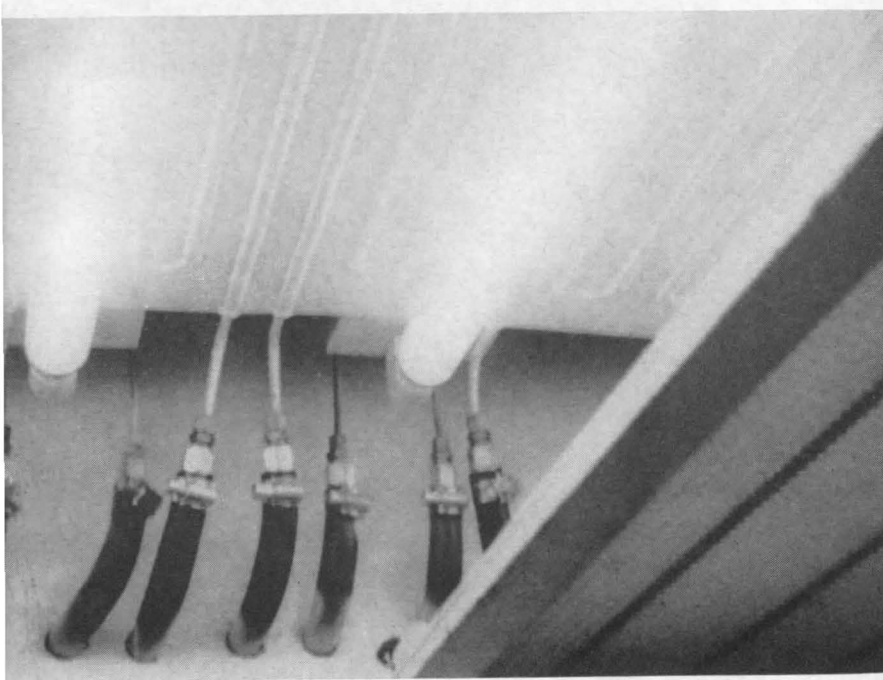

EXPERIMENTAL PANEL COOLING SYSTEM

The sketch at left defines the various elements in an integrated panel cooling—lighting system. As lighting levels go higher, more efficient means need to be found for getting rid of the heat. In the system shown here, all but about 9 per cent of the heat from the lamps can be removed by the upper and lower radiant panels

DESIGN OF A RADIANT LOUVER BY NOMOGRAPH

All of the known factors are circled in the nomograph charts. Lines are drawn through them in the succession shown by the large numbers to end up at number 7, the heat removed by coolant in a radiant louver

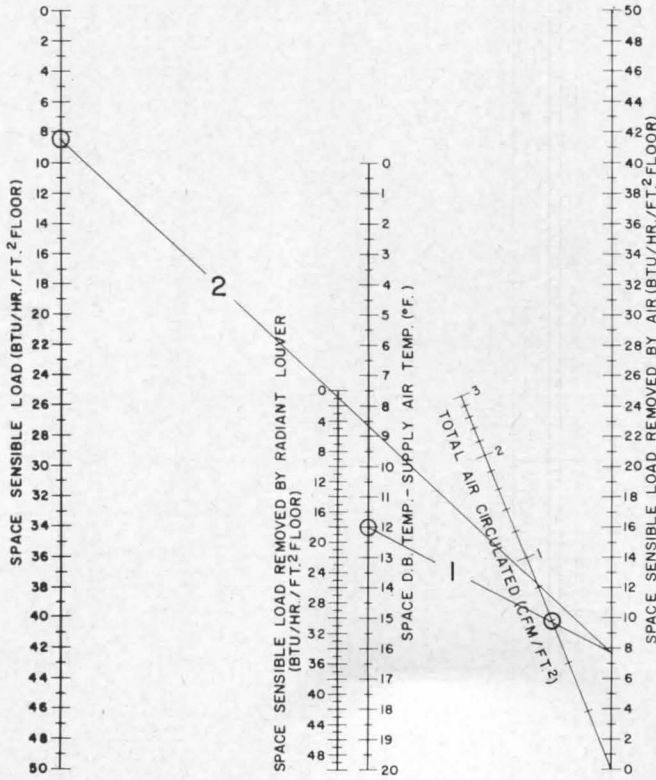

load bearing subfloor. As a component of the building electrical power system, it serves to provide raceways for power, lighting, signal, telephone and security services. As a component in a mechanical system it serves to provide uniform distribution of supply and return air to the conditioned space.

Inherent in the concept of integration of building systems is the ability of the systems designer to select components and arrange them as required in accord with good design practice without restricting the building architecturally. To do this practically, our firm has developed a technique which utilizes nomographs permitting simultaneous evaluation of the variable design factors established by:

1. The architectural designer.
2. The climate and indoor comfort requirements.
3. Occupancy requirements.
4. The mechanical and electrical systems designer.
5. The energy requirements of the associated building systems.

What is required is a more effective method of evaluating and optimizing the design variables of inter-related systems as they affect each other. Where several variables are subject to change and with the magnitude of such changes undeter-

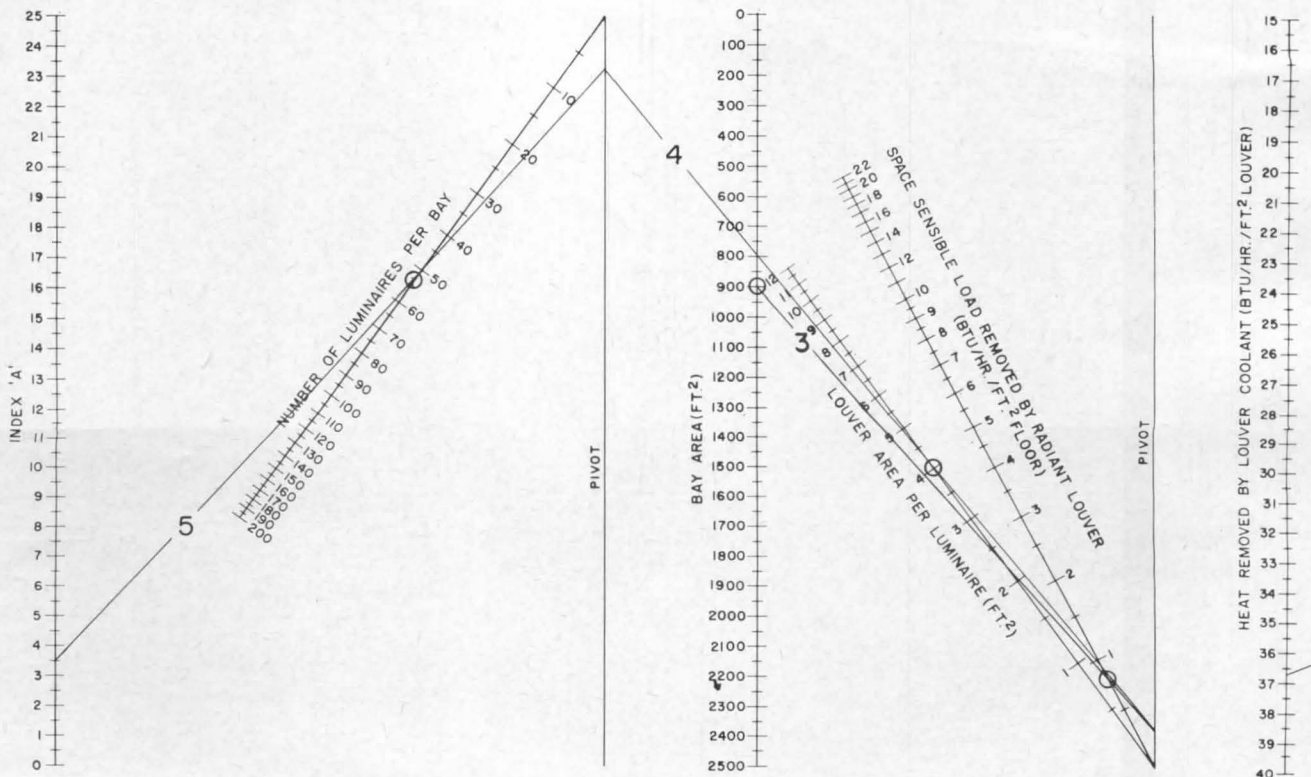

mined, nomographs provide a useful method to avoid repeating arithmetical calculations, while permitting a study of simultaneous changes in several design variables.

NOMOGRAPHS

Nomographs can be prepared to aid and assist the architect and mechanical systems designer in making his material selections and optimizing building energy requirements. Nomographs are geometrically constructed. They represent the mathematical equations which relate quantities known or selected with design factors required for systems evaluation. The effects of changes in all of the major mechanical system design variables can be represented in relatively compact nomographs. Used as described, nomographs:

1. Show the effect of simultaneously changing three or more design variables upon equipment selection and/or arrangement.
2. Eliminate interpolations between several tables or graphs, and minimize design time without loss of a reasonable degree of accuracy.

To demonstrate the application of the nomograph as a design tool let us consider the following problem: Recessed luminaires utilizing single F48PG17/CW lamps are to be used to provide a 150-footcandle installa-

tion. Determine the quantity of heat that must be removed by water coolant in the radiant louver of each 4-ft integrated recessed luminaire to provide space cooling. (This system is similar to that shown on the foregoing two pages.) The interior office space to be illuminated is a 30- by 30-ft bay and the desired conditioned space temperature is 75F. The un-zoned air temperature for all building occupancy zones is established at 63 F and the air circulation rate is 4 air changes per hour. All variations in space temperature shall be controlled directly by the luminaire radiant louver. Occupancy requirements are as follows:

a. One person/75 sq ft.

b. 1.5 watts/sq ft for equipment
The mechanical designer supplies the following information: The space sensible load (aside from lighting) is

| | Btu/ hr-sq ft |
|-----------|------------------|
| People | 3.3 |
| Equipment | 5.2 |
| Total | 8.5 |

Applying the lumen method to determine the number of luminaires required to provide 150 footcandles at the working plane, the electrical designer supplies the following information:

- a. Number of luminaires = 54
- b. Luminaire spacing = 3 ft 4 in.

on centers.

- c. Total lamp watts input per luminaire = 110.
- d. Louver area per luminaire = 4 sq ft.
- e. Total electrical input to lighting system = 8.7 watts/sq ft (29.7 Btu/Hr-ft²).

Referring to the nomograph, all of the known or selected system design variables (designated by circles) are located on the appropriate scales. Solution is accomplished by connecting with straight lines each scale of the nomograph computer in the order indicated by circled numbers. The solution of each section of the nomograph computer requires that any two of the three variables connected as illustrated be known or selected. Determination of the third variable is automatic and is used in the solution of the scale adjacent to it, etc., until a complete path is made connecting all these scales, pivots and indexes of the nomograph computer in the order as illustrated by the line numbers. At number 7 we see that the heat removed by radiant louver at the design load = 36.7 Btu/hr-ft² of louver or 147 Btu/hr per luminaire that must be removed by the mechanical cooling system.

The nomograph illustrated shows the effect of variables normally used in the calculation of space illumination levels on the cooling capability of the combined air convection and radiant cooling mechanical systems. The requirements of space lighting and cooling are determined simultaneously and various luminaires are evaluated from a lighting as well as a cooling capability. The area available for viewing the space load depends upon the number of luminaires required. The lighting load removed by the louver is related directly to the heat equivalent of electrical energy required to operate the lamp sources and the distribution of conductive, convective and radiant energy leaving each lamp source.

SUMMARY

The use of the nomograph as illustrated will help establish the framework for decision making from which the selection of the associated building systems is optimized, and the use of system energies is conserved. Before integration can be achieved, however, the criteria for system design must be established by the architectural designer.

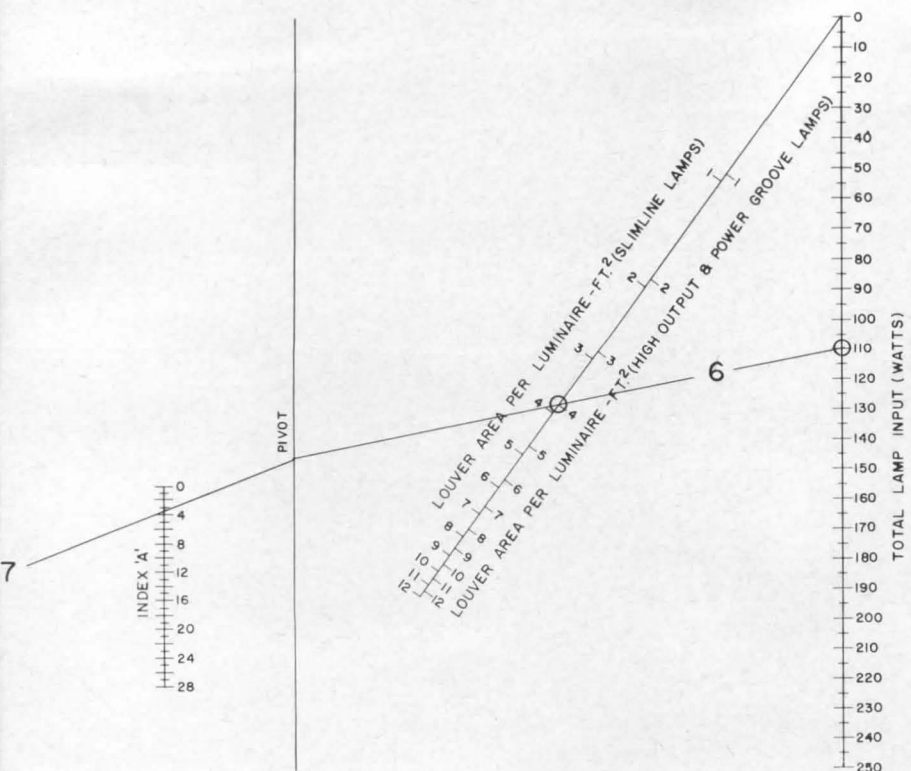

MODEL TESTS PREDICT SPACE FRAME BEHAVIOR

by *Kenneth C. Naslund*

The author worked on the structural analysis described in this article when he was chief structural engineer of Skidmore, Owings & Merrill in Chicago. He is now a partner in the structural engineering firm, The Engineers Collaborative.

Conventional methods of analysis for this space frame would have been either too tedious to run through or overly conservative in results. With a technique rarely used in this country, the designing engineers performed load tests on a plastic model and confirmed the results with a steel prototype. Upjohn Company General Offices, Skidmore, Owings & Merrill, Architects and Engineers

The roof structure of the Upjohn Company office building consists of a series of shallow steel trusses joined to form a space frame.

The design of this type of structure by conventional means is very time consuming. A stress analysis by means of a scale model was selected as the best approach to design. Full-scale field tests were conducted on a 66- by 66-ft prototype to spot check the model test results.

The development of a space frame as a solution for the complete architectural problem involved many factors:

1. The structural system was required to follow the basic module of the building (6 ft square).

2. It was to provide double cantilevers at exterior and interior corners of the building and its many courtyards.

3. The framework was also required to support individual pyramidal domes to form a modulated ceiling, expressing the nature of the structure.

4. The space frame had to be economically designed while satisfying the requirements of design stresses, fabrication, shipment and erection.

Column centerlines are 48 ft apart in each direction with every other bay carrying a 66- by 66-ft unit which provides cantilevers of 9 ft over the centerlines to support the 30- by 30-ft and 18- by 30-ft suspended span units.

Courtyards, with the exception of the largest, are formed by the omission of 30- by 30-ft and 18- by 30-ft suspended span structural units.

The use of conventional methods of analysis for the 66- by 66-ft units was ruled out early because the highly indeterminate nature of the structure would have required an excessive amount of engineering time to solve the many different edge loading conditions on the units. Two possible approaches might have been: 1) a conservative analogy to a plate, or 2) a very conservative estimate of the distribution of stresses in the system by coefficients such as those recommended for use in the design

STEEL PROTOTYPE—66 by 66 ft, 3-ft deep, columns 48 ft o-c

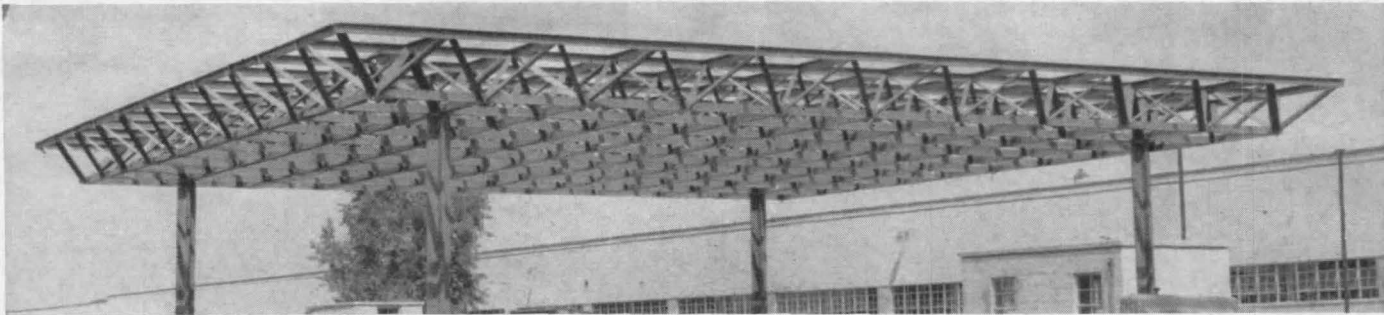

PLASTIC MODEL—built to 1/20 scale

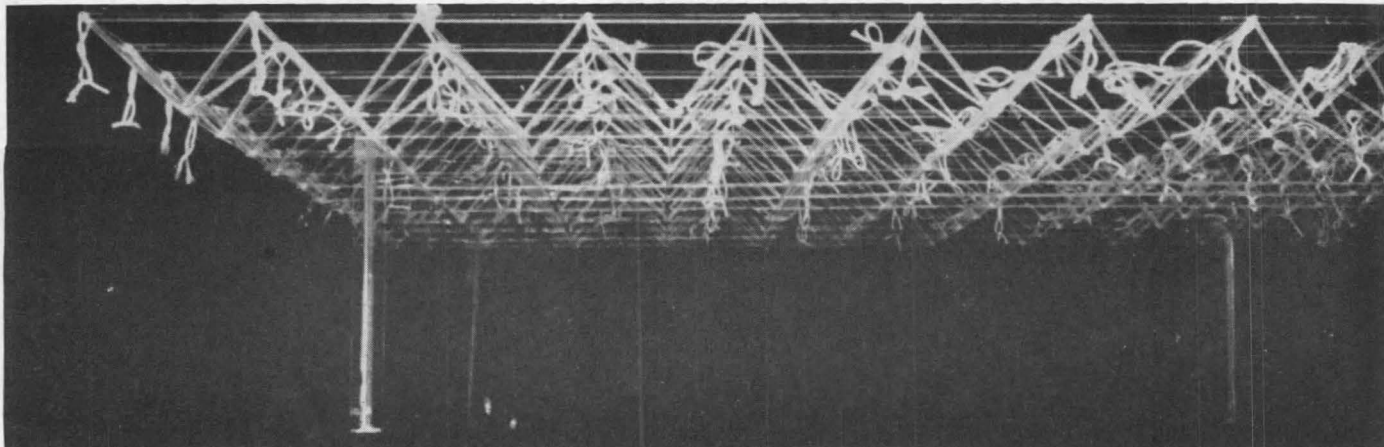

of reinforced concrete flat plate systems. These choices were not satisfactory because they meant a waste of material and a poor engineering approach to solution of the problem. It was decided therefore that the analogy to a plate would be used only to obtain the probable distribution of moments in the system. Steps taken in the structural design were:

1. A small-scale plastic plate flexible enough to give easily measured deflections due to scaled down loads was constructed.
2. Deflections were measured when this plate was subjected to its equivalent uniform load and various edge loadings.
3. From the deflection measurements design moments, preliminary design stresses and member sizes were established. [This procedure is not illustrated nor discussed further in the article.]
4. A model of the three dimensional structure at 1/20 linear scale was built. Stress and deflection measurements were taken.

The scale model was built of acrylic plastic and represented the 66-ft square cantilever unit. It consisted of 779 individual pieces scaled down proportionately from the preliminary member sizes established from the

plate loadings. To shape the model member the same as the structural shapes selected would have been an expensive and unnecessary refinement because the primary stresses in the structure were the direct stresses (tension and compression) with secondary bending stresses consequential only in the immediate vicinity of the columns. Thus, model members were made rectangular.

Because of the geometry of the structure, it was determined that instrumentation on one-half of a quadrant (or one-eighth of the unit) would provide complete design data. Therefore, the more important members in this portion of the unit were instrumented with SR-4 strain gages placed so that both direct stresses and bending could be determined.

The model was tested first with a uniform load and resulting stresses noted. Then a single load was applied at each panel point (every 6 ft) around the perimeter and stresses recorded for all the instrumented members for each of the load positions. With this data, influence diagrams giving stresses for point loadings to simulate weight of suspended spans were developed. Values from these diagrams combined with stresses due to uniform load furnished enough in-

formation for a complete design.

Deflections were also measured on the scale model under uniform load at (1) the center of the bay, (2) the edge at midspan between columns, (3) the column centerline at midspan, and (4) the corner. These values for deflection were verified during the load test on the full scale mock-up.

Typical influence diagrams for deflections and direct stresses derived from the scale model tests are shown on page 000. The ordinates on the influence diagrams for stress represent the direct load in the member resulting from a unit load applied at a position on the ordinate. The numbers along the bottom of the diagram designate the load positions. The sign convention used was positive for tension and negative for compression.

Fortunately, this project, because of its unusual architectural features, required the construction of a full size mock-up of one bay (including the roof structure) to study details of construction. Since it presented a wonderful opportunity to check the model stress analysis, a load test was conducted following a procedure similar to that used on the scale model. Eight members were instrumented with SR-4 strain gages and a

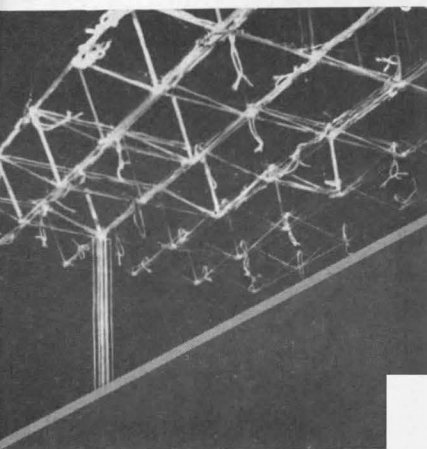
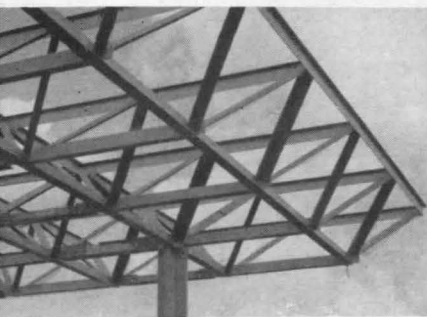

FRAMING PLAN—model and prototype

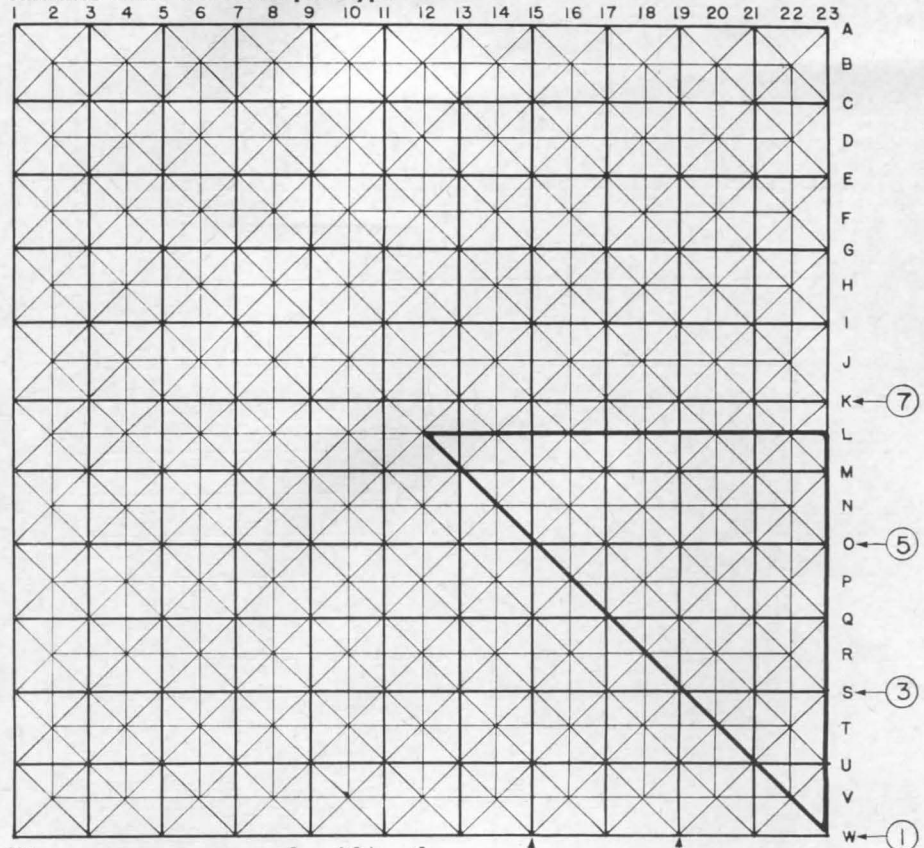

Stresses were measured within the heavy-line triangle. Column is at 20-T

STRESS DIAGRAMS

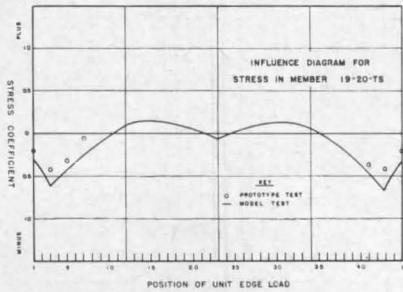
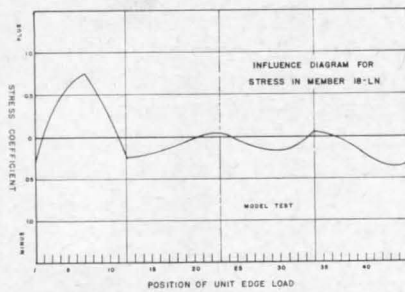
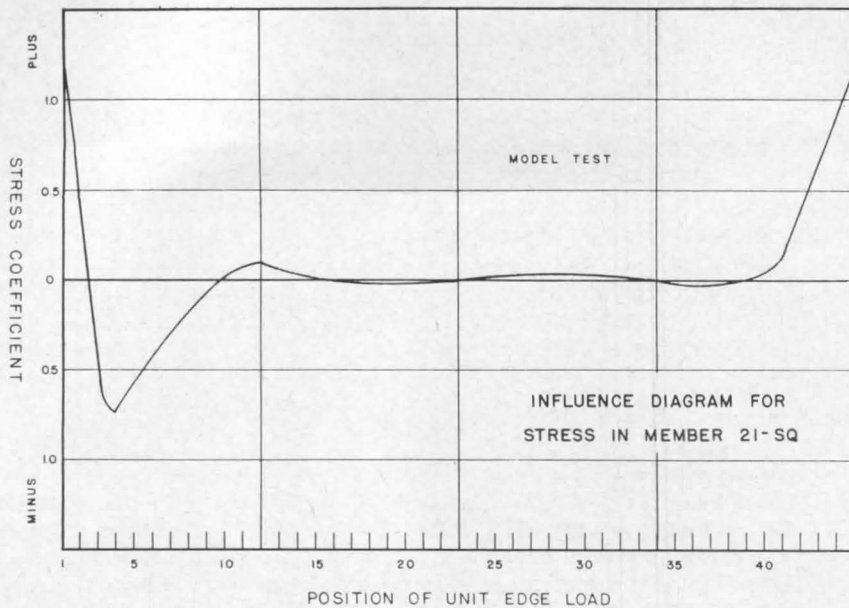

DEFLECTION DIAGRAMS

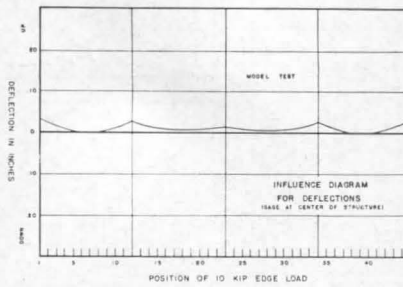
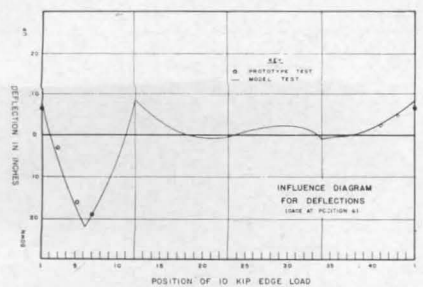
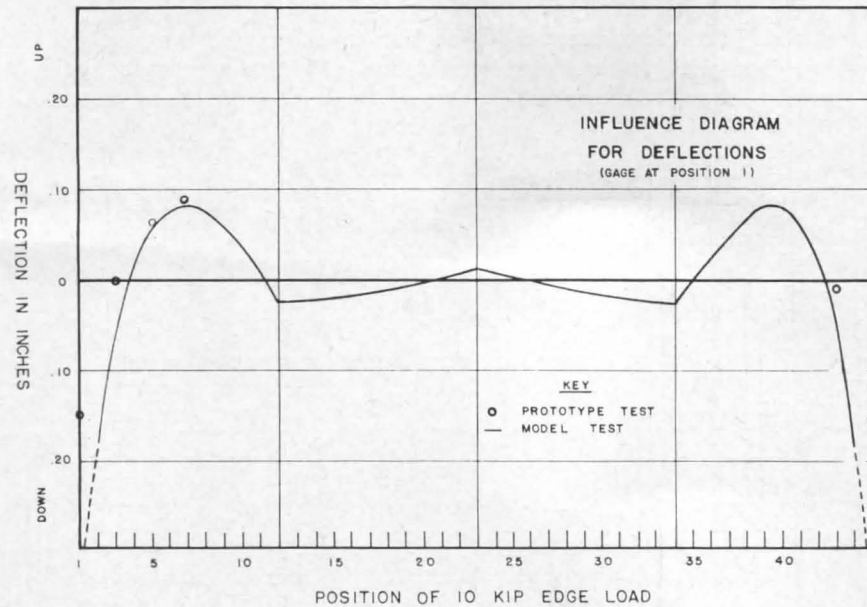

Stress diagrams indicate the relative magnitudes of stress as a unit load is moved around the periphery of the frame. A 10 kip load at point 5 should produce a 7.5 kips compression in member 21-SQ. Deflection diagrams are given here for 10-kip loads at positions 1, 4 and at the center of the space frame

10 kip load applied separately at each of six edge panel points. (These are identified by the circled numbers on the drawing, page 153.) The resulting stresses checked with those predicted from the scale model influence diagrams.

While good agreement was obtained between the scale model and the full size mock-up data for chord members, the diagonals over the column did not have such good agreement. This was attributed to the rather substantial bending which results in these members under load. Full scale mock-up members were structural angles and tees, and those used on the scale model were rectangular in cross section. It is apparent that for any future model analysis where bending is likely to occur in combination with direct stress, the physical shape of the members and the results will have to be subject to critical examination prior to their use for final member selection.

In addition to considerable bending being indicated in the diagonal members directly over the columns, some bending was observed in most of the other members, but this was of minor significance except for the bottom chord members immediately adjacent to the column.

While this method of structural model analysis is basically suited to analysis of truss type structures with direct stresses, it is presently being used for shell type structures as well as building frames. This method could be used to analyze, or check the analysis of special building frames. It undoubtedly produces a much clearer and more complete picture of what various combinations of loads produce in the way of stresses in a complete structure and in a shorter time.

Fabrication and Erection

Steel erection and fabrication of the 1200-ton space frame was performed by Whitehead & Kales Company of Detroit. It consists of over 200 factory-fabricated trapezoidal, triangular and parallelogram sections shipped 150 miles by truck to the site. Each truck shipment consisted of two or three space frame sections along with beams and columns. At the job site, a series of false-work beams were bolted for temporary alignment and positioning of the space frame sections. Most field connections were welded, although 49,000 high-strength bolts were used.

FLOOR FRAMING SYSTEMS: I

by JOHN G. MASCIONI, Assistant Professor, Pratt Institute, Structural Engineer

Basic floor framing schemes are illustrated and described on the following pages. For comparison, typical designs have been developed for each scheme. Four bay sizes, 20 by 20 ft, 20 by 24 ft, 20 by 28 ft, and 20 by 32 ft, have been investigated to note the relative effect of span length on the depth of construction. In general, the average area of the four bays, 520 sq ft, may be considered larger than the economical size bay for wood construction and solid concrete floor systems; approximately economical for the ribbed concrete floor systems;

and smaller than the economical bay for steel and prestressed concrete floor systems. Design is based upon a total superimposed load of 60 lb per sq ft. All dead loads with the exception of the structural floor should be deducted to arrive at the effective live load. As the key plan shows; equal spans are assumed on the sides of the bay investigated. Beams, therefore, are designed to support loads from adjacent bays. Design of the spandrel beam, which depends on all the various construction and architectural re-

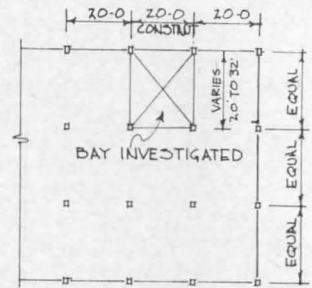

quirements, has been omitted. Reinforced concrete design is based upon 3000 psi (f_c') concrete. The allowable stress in steel for both steel framing and reinforced concrete is 20,000 psi.

1) Wood Joists

A wood-framed structural floor used primarily for residences and one-story buildings. Deflection limits its application for long spans. It is used frequently with wood or masonry wall bearing construction. Design of joists is based upon an $E = 1,650,000$ psi and $f = 1200$ psi. Supporting the joists are plywood box beams with reinforced plywood webs for the heavy shear loads. An adaptation of this system is the stressed skin panel in which the strength and stiffness are increased considerably by glue-nailing plywood to the top and bottom of the wood joists.

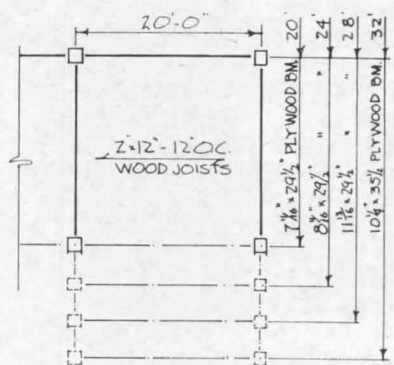
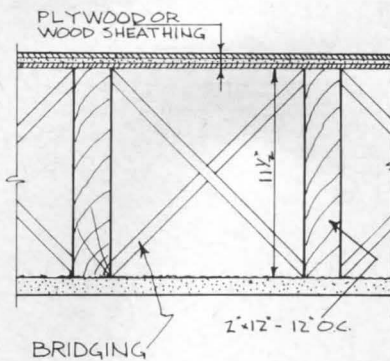

2) Wood Plank and Beam

The depth of floor construction is considered the thickness of the decking which is usually a nominal thickness of 2 in., 3 in., or 4 in. Decking can be either planking laid flat or laminated lumber laid on edge and side nailed. The underside of the decking is usually left exposed. Minimum depth of construction, an important advantage, produces large deflections and limits the application of this system primarily to roofs. Random length planking in which only one end bears on a support is the most economical. Design is based upon an $E = 1,760,000$ psi for wood purlins and 1,800,000 for glue-laminated girders. In smaller buildings a post could be placed under the purlins thereby eliminating the girder.

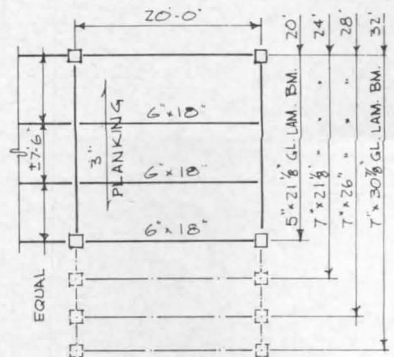
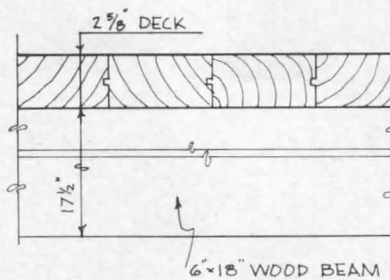



FLOOR FRAMING SYSTEMS: 2

by JOHN G. MASCIONI, Assistant Professor, Pratt Institute, Structural Engineer

3) Open Web Steel Joists

This floor system is widely used and is very economical for light occupancy loads. In addition to the poured concrete slab shown here, it is employed with wide variety of decking and planking commercially available. Open webs facilitate the installation of pipes, ducts, and conduits. Joists tested by the Steel Joist Institute are standardized in depth up to 48 in. for spans up to 96 ft for roofs. The span of joists should not exceed 24 times the depth.

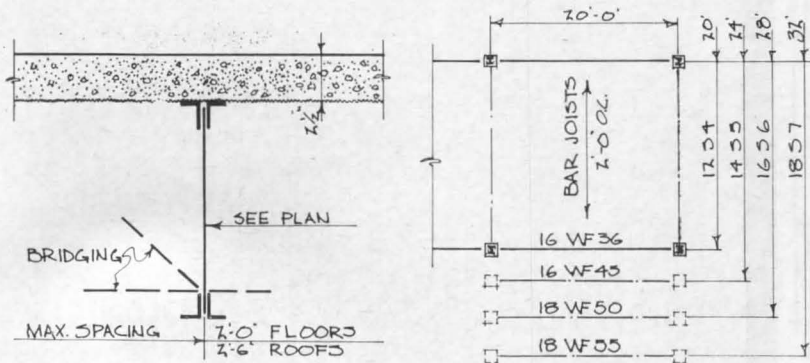

4) Steel Purlins and Concrete Slab

This system is one of the oldest fire-resistant floor systems. Beams should be spaced at approximately 8 ft to permit the use of welded wire fabric. Light weight concrete is used to reduce the dead load of the slab. For its principal application, office buildings, fill is required for the installation of utilities. A modification of this system consists of using lighter sections, such as Junior beams, at closer spacing so that standard plywood forms may be clipped to flanges and easily removed after the slab has hardened.

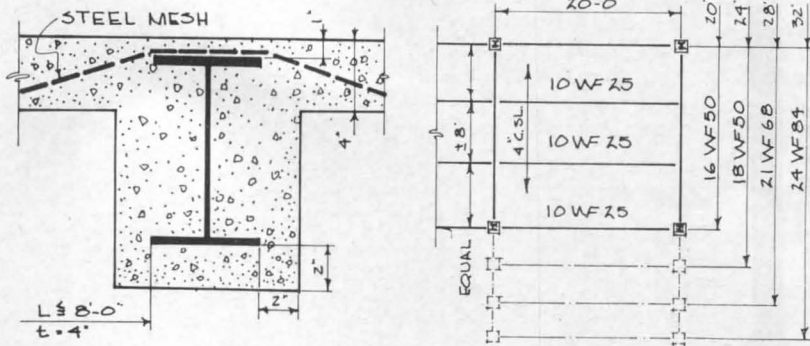

5) Cellular Metal Decking

The principal advantage of this floor system is the flexibility provided by the cells for the installation of utilities and for the location of electrical and telephone outlets. Other important advantages are light weight and fast erection. It is widely used to advantage in office buildings. Available in various depths for both short spans and long spans. Light weight concrete is not structural but serves as fill and finish and for fire protection of the top. In addition to the unit shown here, there are other similar products commercially available. For non-fireproof roofs, decking may be left exposed and the concrete fill omitted. *To Be Continued*

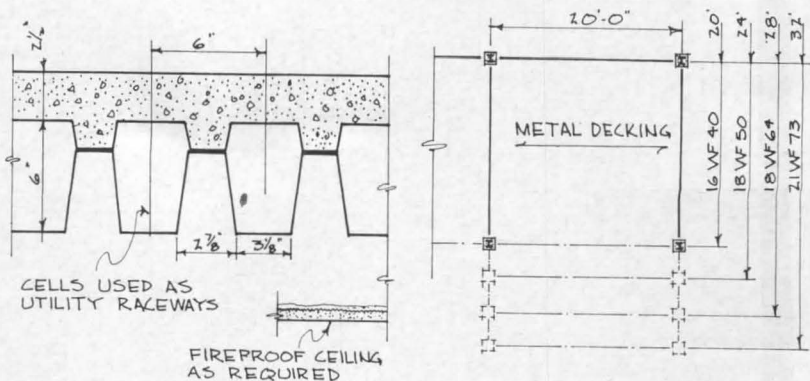

SOUND SYSTEMS

This article discusses the two principal types of sound reinforcing systems—central and distributed. It also goes into the various types of loudspeakers and their proper location. Some of the attendant problems such as location of microphone and speaker to avoid squeal due to feedback are also covered

by Robert B. Newman
and William J. Cavanaugh
Bolt Beranek and Newman Inc.
Consultants in Acoustics

In many situations, to obtain adequate loudness and good distribution of sound it is necessary to augment the natural transmission of sound from source to listener by means of a sound reinforcing system. In large sports arenas, in airport terminal buildings, in large auditoriums and in other noisy locations, it is almost always necessary to provide sound reinforcement. Even in rooms where most strong-voiced speakers can be heard clearly, the weaker voices must be amplified, and there is often the requirement for amplifying recorded material or movie sound. In all cases, however, the design of the sound reinforcing system *must* be carefully integrated with the design of the room and with its acoustical characteristics.

Sound reinforcing systems consist of three essential components: microphone (means "very small sound"), amplifier, and loudspeaker. The microphone is placed somewhere near the source of sound; it picks up the sound energy radiated by the source and converts it into electrical energy which is then fed to an amplifier. The amplifier increases the magnitude of the electrical signal and supplies it to the loudspeaker which converts the electrical energy to air-borne sound energy again for distribution to the listeners at the proper level. (See Fig. 1).

There are two principal types of sound amplification systems: central and distributed. The preferred type in most situations is the central system in which a loudspeaker (or cluster of loudspeakers) is located directly above the actual source of sound. Only *one* loudspeaker position is used in a system of this sort, and it is capable of giving maximum realism. (We will not be concerned here with "stereo" sound playback systems.) The listener with his two ears is able very readily to localize

the direction of the source of sound and, if the amplified signal comes from the same direction as the original sound, he gets an impression merely of increased loudness or clarity but not of artificial "amplified" sound. (Fig. 2.)

The other principal type of sound reinforcing system is the distributed type. In this system one uses a large number of loudspeakers located *overhead* (not along the sides of the room facing across), and usually a low level amplified signal is supplied to a small area. This type of system operates much like down-lighting. We cover the room with small "pools" of sound, each listener receiving sound from only one loudspeaker. This type of system is used in any situation where the ceiling height is inadequate to use a central system or where all listeners cannot

have line-of-sight on a central loudspeaker. It is also used in such spaces as large convention halls, hotel ballrooms, or large conference rooms where there must be a very flexible arrangement of the space for amplifying sources of sound in any position in the hall. It is the logical system for most airport terminal buildings where the amplified signal usually must be somewhat higher in level in order to override the high background noise levels due to aircraft operations. The distributed system is a flexible system, and, while it does not give maximum realism, in reinforcing live activities, it can be made to provide high intelligibility in many difficult situations. (Fig. 3.)

In good practice today one rarely locates loudspeakers at the two sides of the proscenium opening, nor does

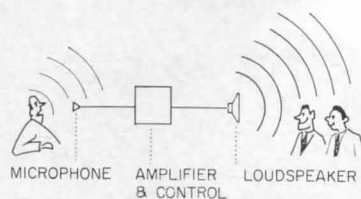

Fig. 1. Basic elements of a sound reinforcing system

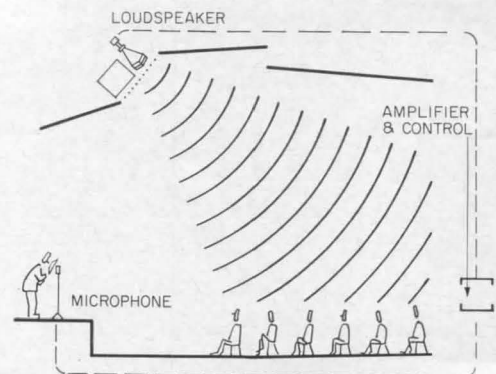

Fig. 2. Central loudspeaker system

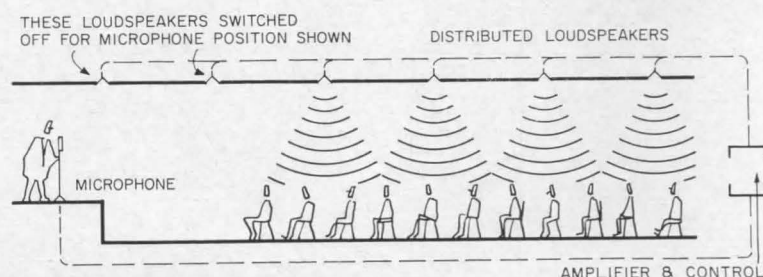

Fig. 3. Distributed loudspeaker system

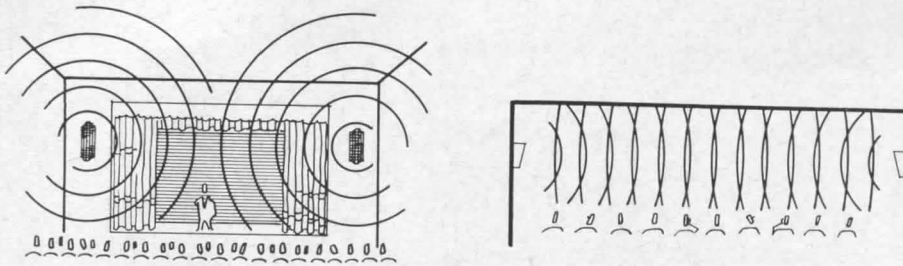

Fig. 4. Poor loudspeaker placement can mean ineffective sound reinforcement

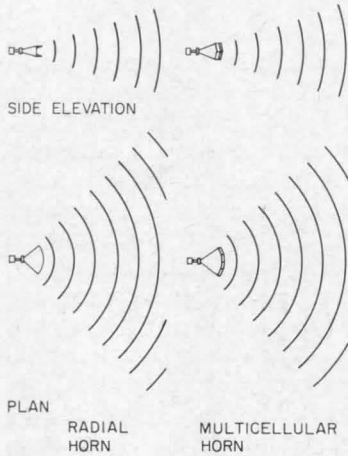

Fig. 5. Horn-type highly directional loudspeakers and their coverage patterns

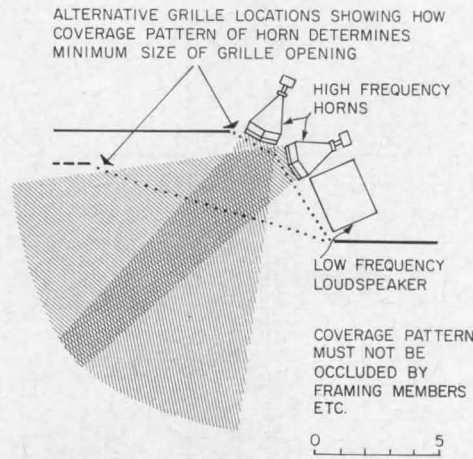

Fig. 6. Loudspeaker grille sizes are determined by the coverage patterns of the loudspeakers behind them

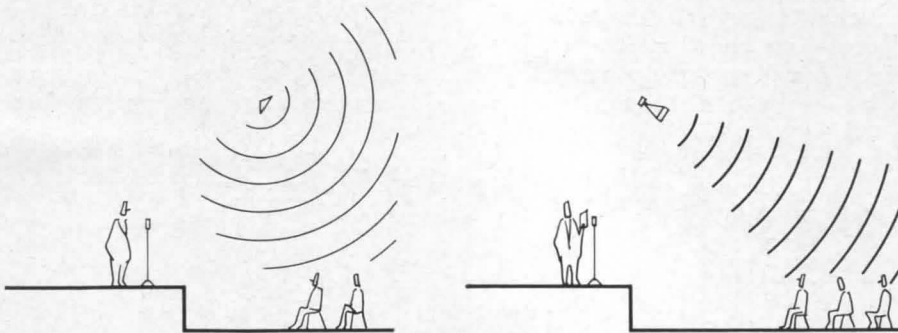

Fig. 7. "Feedback" to the microphone can result unless the loudspeaker location and directional characteristics are carefully considered

one have a crossfire from loudspeakers distributed along the two sides of the room, nor as in one recent instance, from the four corners of a large reverberant space. These "semi-distributed," semi-high level systems never work well, and the hearing conditions in a space can usually be improved by actually shutting them off! (Fig. 4.)

Central Systems

The loudspeaker for a central system usually consists of a cluster of directional horns, some of which handle the high frequency end of the audible spectrum, and larger loudspeakers

handling the low frequency end of the spectrum. The high frequency horns are usually exponential, multicell or radial horns and are arranged in clusters to give coverage of specific areas of the seating. It is important that the horns have excellent directional characteristics, and that the level of operation of the several units be individually adjustable. Bends or folds in horns usually destroy their evenness of coverage and directional control; both the radial and exponential horns usually employ direct expansion of the wave front. One cannot achieve high quality sound amplification without loud-

speakers with carefully controlled directional characteristics (see Fig. 5.) If a loudspeaker system is to be used only for speech purposes, the system need not have any low frequency loudspeakers and can be housed in a smaller space than a full frequency range system used for music as well. Usually, a speech system is cut off at approximately 300 cycles per second (i.e., these loudspeakers do not amplify sounds below that frequency). This results in no loss in realism and actually improves intelligibility in rooms with "boomy" characteristics.

The designer of an auditorium incorporating a loudspeaker system must realize that the loudspeaker system will take a great deal of space and that it cannot be tucked conveniently into a one-foot slot. The grille in front of the loudspeaker must be completely transparent to sound and must contain no large scale elements (see Fig. 6.) Every listener in the room must have line of sight on the loudspeaker; we do not count on reflection of sound from room surfaces to fill in any areas not covered by direct line of sight.

The operator of the sound system should be located toward the rear of the seating area where he can hear the system as it is heard by the audience. He should not be behind a glass window in a booth, receiving sound only on a monitor loudspeaker. The power amplifiers can be in any convenient location but the actual controls must be "in the room."

Microphones must be placed near the sources of sound and, if there are to be many sources, as in the amplification of a play, there must be many microphones suspended overhead or concealed in the scenery so that the actors are always relatively close to these pickup devices.

There is the important problem of feedback of sound energy from loudspeaker to microphone, and the relative locations of microphones to the loudspeakers must be carefully considered to avoid the familiar squealing or howling of a poorly designed and operated system. This is a matter for detailed consideration by the designer of the system, and is not primarily an architectural question except in so far as relative location of loudspeaker to microphone is concerned. (Fig. 7.)

(To be concluded in January)

ACOUSTIC CEILING DOUBLES AS CONDITIONED-AIR OUTLET

A showroom of Armstrong flooring and acoustical ceiling products opened recently at 60 W. 49th St., New York City. One feature is the Armstrong *Ventilating Ceiling* which distributes conditioned air throughout the room. This product combines the functions of sound-conditioning, decoration, and room-air distribution in a single material.

It is designed not only to improve air conditioning effectiveness, but to save construction costs by eliminating conventional air diffusers and simplifying duct work. Blended into the ceiling's surface design are thousands of tiny perforations which allow conditioned air to filter directly into the room through the entire ceiling surface. This diffusion method helps eliminate drafts and air-conditioning noise. Moreover, the ceiling is said to be self-cleaning, the continuous down-pressure of air providing a barrier against accumulation of dirt. *Armstrong Cork Co., 4200 Miller St., Lancaster, Pa.*

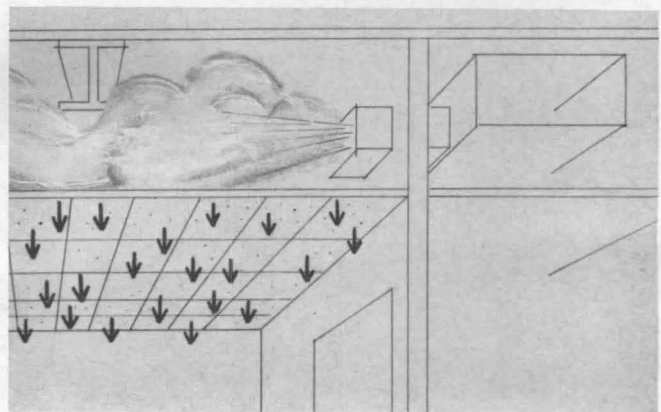
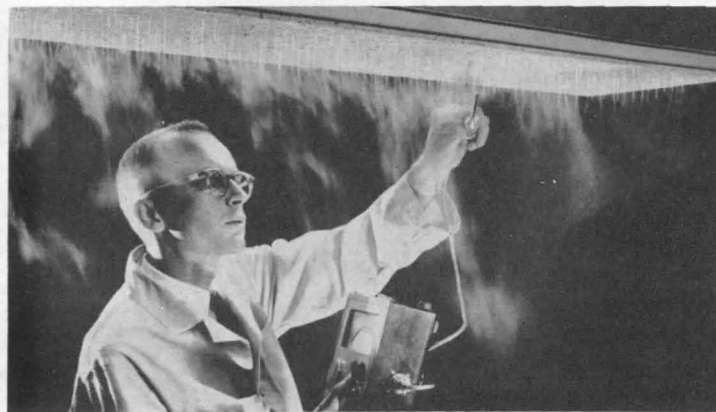
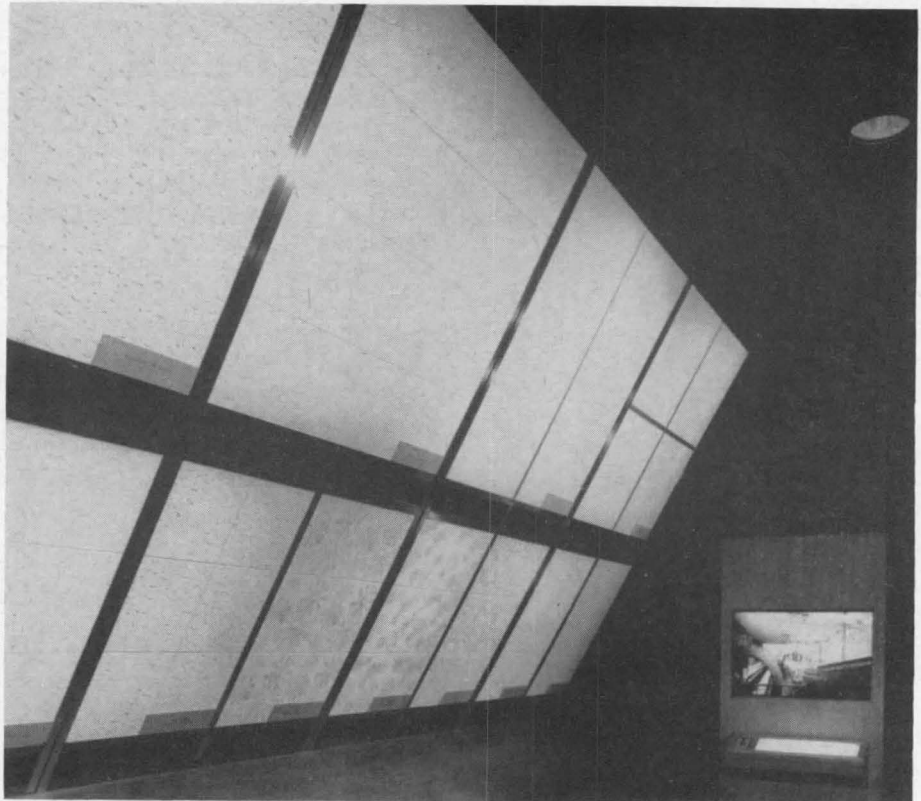

DIAL COLORS FOR PRECISION MATCHING

An automated color communications device called *Telecolor* offers virtually limitless color demonstrations on a screen 11½ in. in diameter. The machine looks much like a television set. By turning a series of dials (each controlling the proportion of a basic color), rapidly rotating color discs meld into specific shades or hues. The device provides accurate color matching in a size large enough to eliminate optical confusion.

Capabilities of the machine were demonstrated at a press preview by

random color selections transmitted by phone in code numbers between New York and Chicago and dialed on *Telecolor* sets with integrity. Colors dialable on the set can be made into actual paint colors by mixing machines. Primary users are expected to be paint dealers, architects, professional painters, interior decorators and educational institutions.

Sets will be available on a lease-purchase arrangement. *Valspar Corp., 200 Sayre St., Rockford, Ill.*

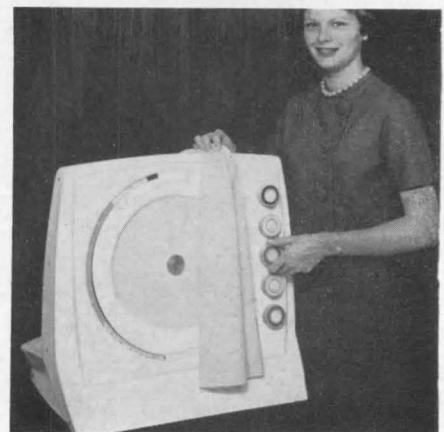

more products on page 168

"Black Light"

"Black Light," the near-ultraviolet radiant energy which causes certain materials to fluoresce, can be of special value to lighting designers and engineers. Booklet LS-141 gives information on black light sources, representative black light applications and basic black light design procedures. *Inquiry Bureau, Dept. B1-61, General Electric Co., Nela Park, Cleveland 12, Ohio.*

Wood Panels

Ways to use *Masonite* wood panels in motel interiors and exteriors are graphically presented in a 16-page booklet. *Masonite Corp., 111 W. Washington St., Chicago 2, Ill.**

Pass Windows

(A.I.A. 16-1) An illustrated folder gives details about vertical sliding pass windows, either stainless or plain painted steel, designed for use in food service areas between kitchen and dining room. *The Richmond Fireproof Door Co., P. O. Box 911, Richmond, Ind.**

Air-Conditioning and Heating

Six new technical catalogs are available from Dunham-Bush, Inc. Manual #789 has 58 pages of application of *Brunner* multi-drive compressors. Specifications and rating tables on air conditioning and refrigeration compressors are included in Bulletin #790. A compact line of air handling units are explained in Bulletin #6011C. Bulletin #6001A presents an engineering guide for direct expansion coils. A line of steam heating specialties is presented in a new catalog, Form 1501D. Form 1551B is a revised edition of the hot water heating equipment catalog. *Dunham-Bush, Inc., West Hartford, Conn.**

Butyl Rubber

A description of the various forms of butyl rubber and its uses for roofing, weatherseals, floor cushioning, sound and shock absorbing pads, gaskets, etc. is available in an eight-page booklet. *Enjay Chemical Co., 15 W. 51st St., New York 19, N.Y.*

Interior Movable Walls

Designs possible with a new series of movable partitions are pictured, along with detailed information about the partitions. *Mills Co., 965 Wayside Rd., Cleveland 10, Ohio.**

Fibercast pipe

Description, details and specifications are given for *Fibercast* pipe, a glass fiber reinforced plastic pipe developed to handle special pressure and corrosion problems. *Fibercast Co., Box 727, Sand Springs, Okla.*

Marine Retail Establishments

The Outboard Boating Club of America has directed the compilation of three manuals on marine retail establishments. Of special interest to architects is a 34-page manual, "Setting the Stage for Sales" by Milton Woll of *Booz, Allen and Hamilton*. This manual covers space requirements for boat displays, servicing, plot selection, lighting, etc. Other manuals cover boating salesmanship and management of marine retail establishments including record forms, advertising, etc. *Outboard Boating Club of America, 307 N. Michigan Ave., Chicago 1, Ill.*

Visual Aid Facilities

Audio-Visual Guide to Better Projection gives architectural arrangements for the most effective showings of films, slides and filmstrips. *Radiant Mfg. Corp., AVG, 8220 N. Austin Ave., Morton Grove, Ill.*

Plywood Sidings

An assortment of plywood sidings to fit any architectural style is described in a 15-page brochure which gives technical data as well as design ideas. *U.S. Plywood, Dept. PR, 55 W. 44th St., New York 63, N.Y.**

Porcelain Enameled Curtain Walls

(A.I.A. 17-A) Color photographs illustrate an eight-page booklet describing *Calcore* panels which have faces of porcelain enameled steel, insulated cores and metal backup sheets or pans. Insulating materials include fiber glass; cement asbestos board; plywood; or honeycombs of paper, aluminum or asbestos. *Caloric Corp., Architectural Porcelain Div., Topton, Pa.**

Erosion-proof Cements

Details about six erosion-proof cements are given in a 12-page bulletin. *Atlas Mineral Products Co., Mertztown, Penn.*

*Additional product information in *Sweet's Architectural File*
more literature on page 186

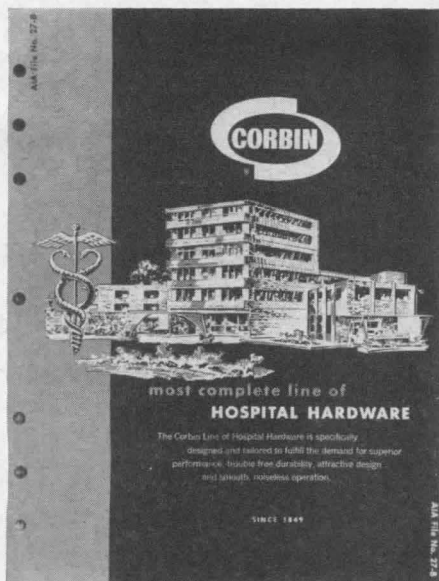

Hospital Hardware

(A.I.A. No. 27-B) An eight-page bulletin describes and illustrates Corbin hardware specifically designed for hospital applications. Line includes door controls, locks, hinges, etc. *P. & F. Corbin Div., American Hardware Corp., New Britain, Conn.**



National Seamless Steel Pipe Piles

CUT CONSTRUCTION COSTS
WITH SEAMLESS STEEL PIPE
PILES BECAUSE THEY CAN
BE DRIVEN HARD AND FAST
...THEY PROVIDE POSITIVE
PENETRATION THROUGH EVEN
THE MOST RUGGED DRIVING
CONDITIONS WITHOUT BROOM-
ING. AND YOU CAN SPLICE
THEM FOR EXTRA LENGTH

**YOU CAN CHECK SEAMLESS
STEEL PIPE PILES AFTER
THEY'RE DRIVEN MERELY
BY LOWERING AN ELECTRIC
LIGHT INTO THE PILING.
THIS WAY, YOU CAN CHECK
THE ALIGNMENT, PILE CON-
DITION AND EVEN THE BEAR-
ING AREA IF THE PILING
IS DRIVEN OPEN END**



USS and National are registered trademarks



National Tube Division of United States Steel

Columbia-Geneva Steel Division, San Francisco,
Pacific Coast Distributors
United States Steel Export Company, New York



United States Steel Corporation
National Tube Division
525 William Penn Place
Pittsburgh 30, Pennsylvania

Please send me more information about
Seamless Steel Pipe Piles.

Name

Company

Address

City

Zone State



This mark tells you
a product is made of
modern, dependable Steel.

Product Reports

continued from page 163

Two-Faced Gypsum Panels

Wall panels with strong honeycomb cores faced on both sides with gypsum wallboard reduce installation time and cost because the panels can form complete wall sections without conventional stud framing. To erect these *Hof-Kor* panels, corresponding plates are nailed to the floor and ceiling rafters. Panels are placed in position and attached to plates. Hollow metal splines at joints hold panels in alignment and provide raceways for electrical conduits. *Hoffman Industries, Inc., Batavia, Ill.*

Outdoor Infrared Fixtures

Two infrared fixtures are available equipped with T3 tubular quartz lamps for both heat and light or quartz tubes for heat without light. Designed for unsheltered outdoor applications, they have waterproof housings of 14-gage aluminum with a gray baked enamel finish. One of the models is a hanging fixture and may be chain mounted on either a

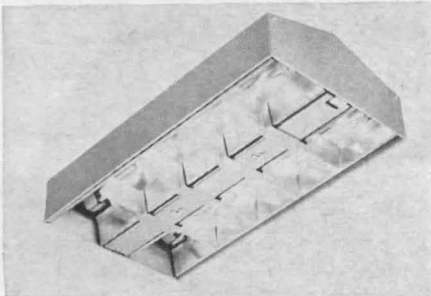

vertical or horizontal stem. The second model is mounted on horizontal surfaces and can be used for indoor flush ceilings. *Luminator, Inc., 120 N. Peoria St., Chicago 80, Ill.*

Electro-Hydraulic Heating System

A heating system which uses electricity at night depends on the services of a heating contractor rather than an electrical contractor. Called *Off-Peak* system, immersion coils in the boiler heat water at night from 150 to 240 F and stores the water in storage tanks adjacent to the boiler. There are zone valves for fuel economy. The complete package includes boiler, circulator, zone valves, storage tanks and baseboard radiation. Operating costs are said to be reasonable. *Edwards Engineering Corp., Pompton Plains, N.J.*

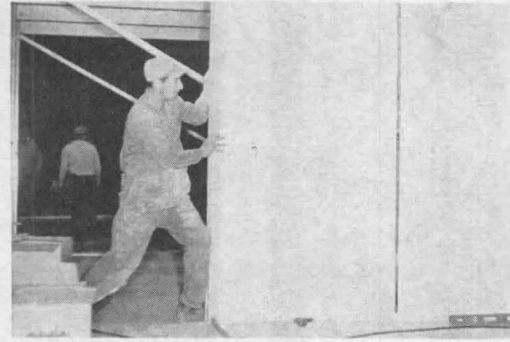
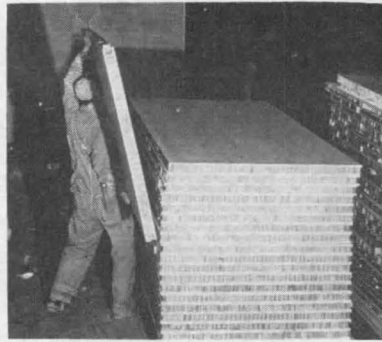

more products on page 172

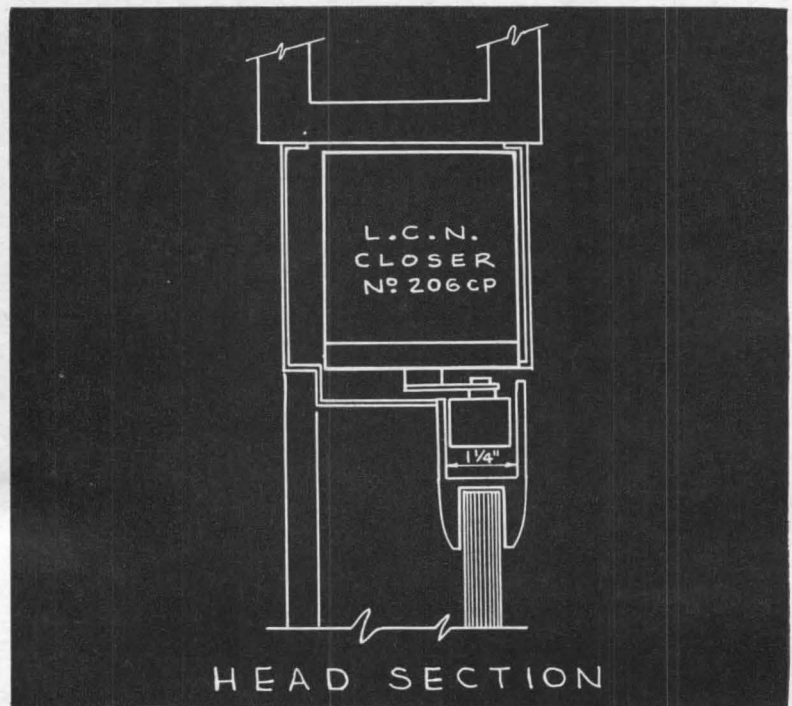

CONSTRUCTION DETAILS

For LCN Overhead Concealed Door Closer Shown on Opposite Page

The LCN Series 200-CP Closer's Main Points:

1. Efficient, full rack-and-pinion, two-speed control
2. Mechanism entirely concealed; arm disappears into door stop on closing
3. Hydraulic back-check prevents door's being thrown open violently to damage walls, furniture, door, hinges, etc. Door may open 130°, jamb permitting
4. Hold-open (optional) set at any one of following points: 85°, 90°, 100° or 110°
5. Easy to regulate without removing any part
6. Used with either wood or metal doors and frames

*Complete Catalog on Request—No Obligation
or See Sweet's 1961, Sec. 18e/Lc*

LCN CLOSERS, PRINCETON, ILLINOIS

A DIVISION OF SCHLAGE LOCK COMPANY

Canada: LCN Closers of Canada, Ltd., P. O. Box 100, Port Credit, Ontario

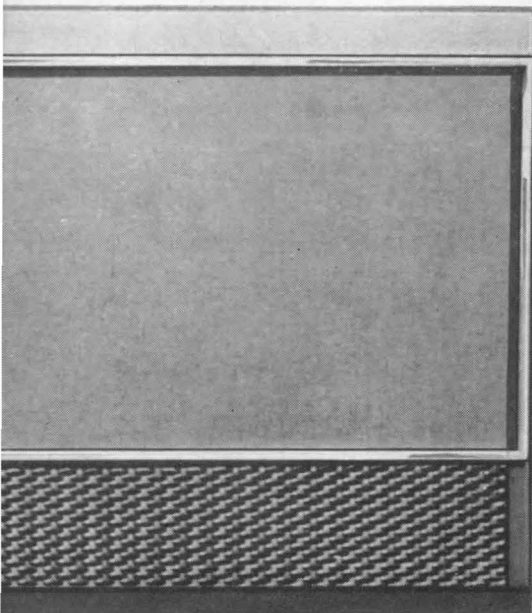

ADVANCED ARCHITECTURAL STYLING

New Herman Nelson Unit Ventilator styling was inspired by the distinctive patterns of modern school architecture. This new styling was acclaimed by Product Engineering magazine as an "outstanding achievement in product engineering and design". Decorator panels are available in six beautiful colors. Basic unit color is charcoal with aluminum trim. Gracefully "lanced" intake grilles and extruded aluminum top discharge grilles help the unit efficiently "breathe" fresh-air atmosphere into the school classrooms.

outlive the school you put it in!

EVERY Herman Nelson Unit Ventilator is expertly designed from the inside out to provide accurate room-by-room thermal control for the life of your new school building.

Here are four of the many special Herman Nelson features which assure long, reliable unit ventilator service:

- 1 Single-unit welded frame construction
- 2 Corrosion-resistant "bath" for unit and damper frames
- 3 Special low-sound-level fan housing design
- 4 One-piece filter system

Consistent product improvements have led architects and school officials to expect the best first from Herman Nelson for over 50 years. Herman Nelson developed the first commercially successful unit ventilator, the first hot water heating element for unit ventilators, the first downdraft control system, and most recently, the first air conditioning unit ventilator.

Write for a free copy of the new full-color Herman Nelson Equipment Guide for Schools. Herman Nelson School Air Systems Division, American Air Filter Company, Inc., 259 Central Avenue, Louisville, Kentucky.

Herman Nelson

SCHOOL AIR SYSTEMS DIVISION

American Air Filter Company, Inc., Louisville, Kentucky

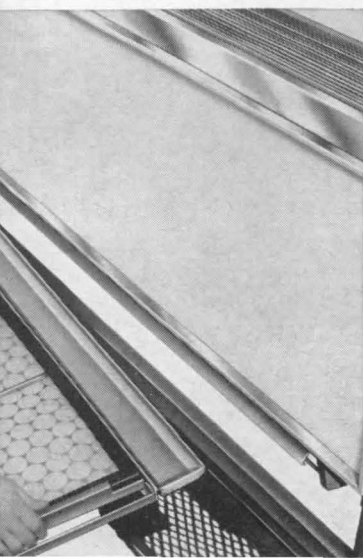

EFFICIENT ONE-PIECE FILTER SYSTEM

Herman Nelson's one-piece filter system permits the mixture of outdoor and room air to pass through the entire filter area at all times. This is important. Split filter systems "hide" the second filter which is often overlooked when time comes to change the filters. This damages filter efficiency by reducing full outdoor air delivery and restricting cooling capacity. Filters on Herman Nelson Unit Ventilators are easily accessible through lower front panel (see photo).

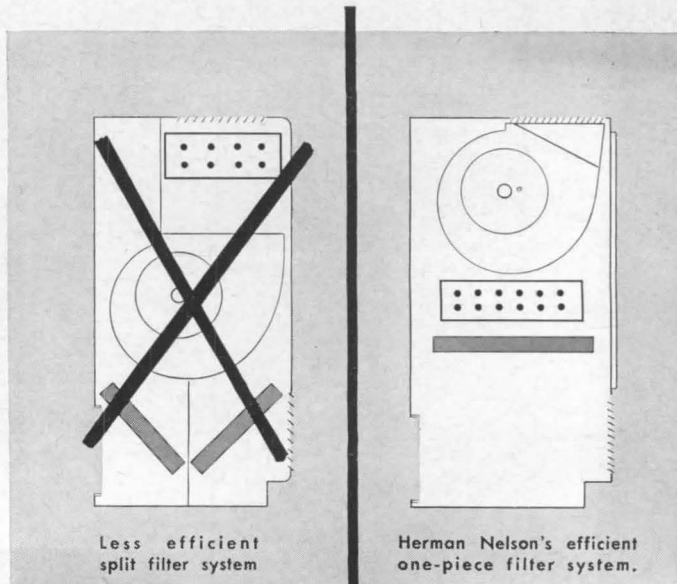

Less efficient split filter system

Herman Nelson's efficient one-piece filter system.

CIRCLGRID 45

LIGHT CONTROLLING VINYL LOUVERS

- Unique cellular design for rigidity and lightness—weighs only 3 1/2 oz./sq. ft.
- 500 Circular openings/sq. ft. for circulation of cooling air
- Approved for installation under sprinklers
- Emits up to 25% more light than other louvers
- Self-extinguishing—UL rated 20 (Tunnel test)

PATENT APPLIED FOR IN U.S.A. AND FOREIGN COUNTRIES



PHOENIX, ARIZONA



Office Area—Circlgrid Ceiling Total Area—10,000 Sq. Ft. Commission of Arizona

DETROIT, MICHIGAN



Circlgrid Luminous Ceiling installed in retail store

ERIE, PA.

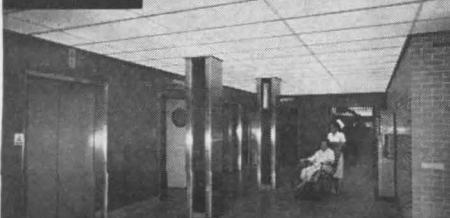

Circlgrid Luminous Ceilings cover 11,000 Sq. Ft. at Hamot Hospital's new addition.

Approved by building codes of most major cities

CIRCLGRID goes where quality counts

Using the entire ceiling to enhance interiors gives the architect a new design horizon. Circlgrid light controlling louvers provide a pleasing permanent design that transforms the entire area into an efficient light source—eliminates glare concentrations common to conventional unit lighting. May we refer you to Circlgrid installations near you for your study?



Write for sample and test data

Address Box 655, Erie, Pa.



Division—The Wilson Research Corp.

Product Reports

continued from page 168

Vertical Acoustical Curtains

Vinyl and lead acoustical curtains, complete with chalk panels, are electrically operated and housed in a

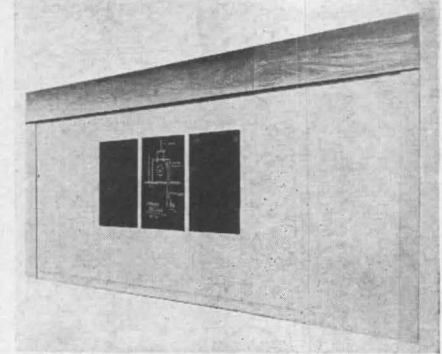

ceiling enclosure of 18 in. *LeadX*, 1/8 in. thick, gives a frequency transmission loss average of 32 db. *Torjessen, Inc.*, 209-25th St., Brooklyn 32, N.Y.

Roof Coating

Neoprene, hypalon and chopped glass fibers combine to make a roof covering that can be sprayed on roofs of unusual geometric form. Any color is available by using hypalon as the final color coat. *Ply-O-Glas Co. of America*, 50 Cutter Mill Road, Great Neck, N.Y.

Window Coverings of Plastic

Three-inch thermoplastic squares make up a window covering which reduces sun-induced heat by reflecting a high percentage of infra-red rays. The interlocked squares, vented for

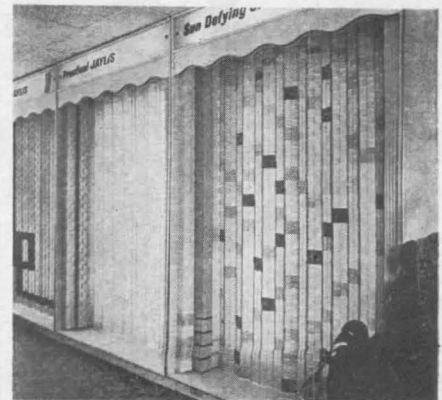

light and air, come in 22 colors. The covering is suspended on nylon rollers from drapery tracks when stacked, it takes up only 1/12th of the extended width. *Jaylis* can also be used as a room divider, door, and wall screen. *Jaylis Industries, Inc.*, Los Angeles, Calif.

more products on page 176

Improve visibility three ways with J-M Colorlith[®] chalkboards

Now you can provide classrooms with strong, durable, beautiful chalkboards that are truly easy on the eyes. With Johns-Manville Colorlith, you get uniform texture, minute pore structure and pleasing shades to eliminate the three major causes of poor chalkboard visibility: chalk build-up, low visual contrast and harsh colors.

Colorlith is a dense, homogeneous sheet that provides a smooth, hard-writing surface that is extremely easy to clean. Because its minute pores cannot fill with chalk particles, dust build-up is cut to a minimum. This means infrequent

washings, too! Colorlith's asbestos-cement structure takes chalk easily, thus permitting full, unbroken lines for easy readability. And, Colorlith is available in three eye-pleasing colors—Spruce Green, Cameo Brown and Charcoal Gray. Extensive research and testing have proved these colors the most restful to the eyes.

Because of its unique composition, Colorlith retains its excellent properties over the years. For full details on this high-quality chalkboard, write to J. B. Jobe, V.P., Johns-Manville, Box 14, New York 16, N. Y. In Canada: Port Credit, Ontario. Cable address: Johnmanvil.

ADDITIONAL CLASSROOM USES FOR COLORLITH CHALKBOARD



PARTITIONS

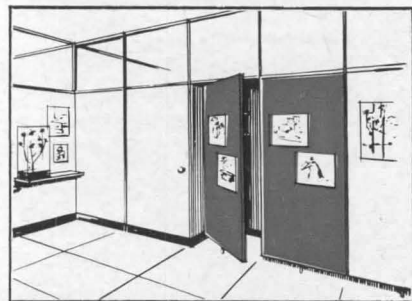

DOORS

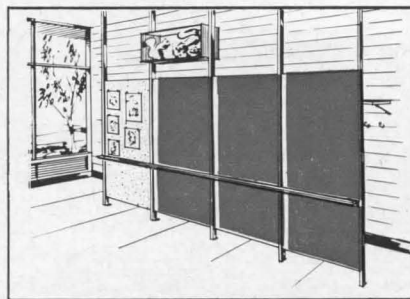

WARDROBES

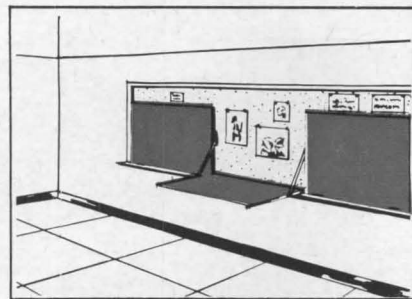

CONVERTIBLE UNITS



JOHNS-MANVILLE

Where power blackouts must not happen

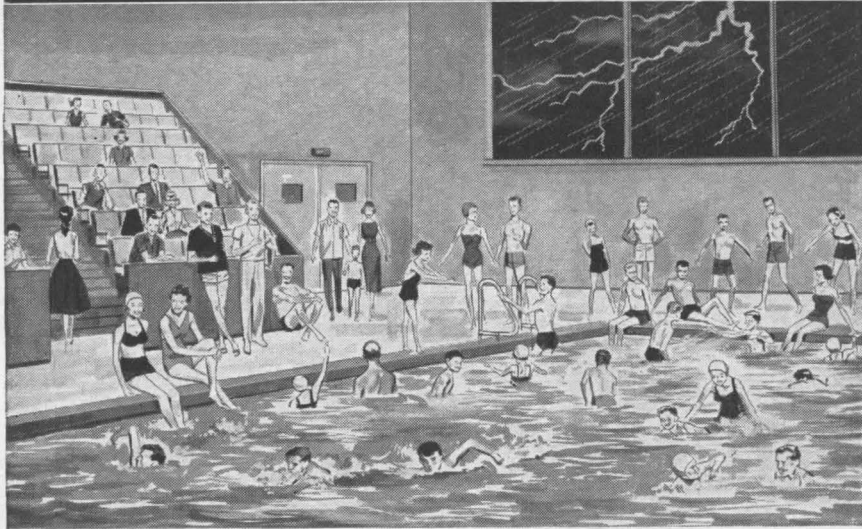

Save the children... specify

KOHLER ELECTRIC PLANTS

Sudden darkness can cause panic and disaster.

When normal power fails, Kohler electric plants provide immediate electricity—lighting for swimming pools, auditoriums, gymnasiums, corridors,

stairways, exits, power for automatic heat.

Increasing dependence on electrical equipment makes emergency power vitally important in schools, hospitals, other public and commercial buildings as well as the home. And Kohler electric plants are known everywhere for reliability.

To help you write specifications for varied applications, Kohler Co. will send on request a manual with data on sizes from 1000 watts to 115 KW, gasoline and diesel. Write Dept. K-12.

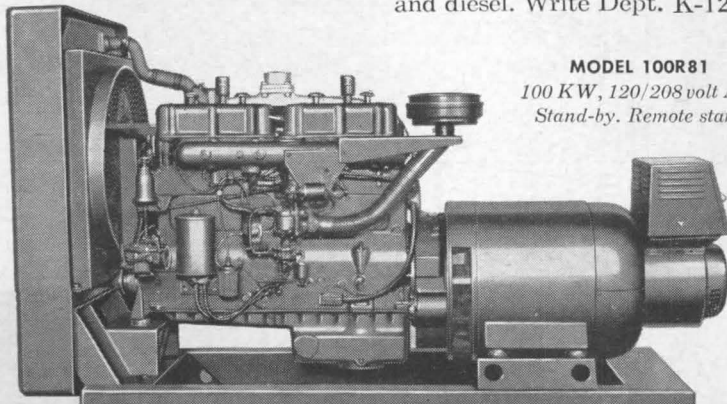

MODEL 100R81
100 KW, 120/208 volt AC.
Stand-by. Remote start.

KOHLER CO. Established 1873 KOHLER, WIS.

KOHLER OF KOHLER

Enameled Iron and Vitreous China Plumbing Fixtures • All-brass Fittings
Electric Plants • Air-cooled Engines • Precision Controls

Product Reports

continued from page 172

Assembly Line Lighting

Enclosed fixtures, gasketed to keep out dirt and easy to clean, provide



high illumination for assembly lines and other industrial uses. *Paramount Industries, Inc., G-1080 Ballenger Road, Flint, Mich.*

New Types of Terrazzo Floors

Two types of terrazzo flooring use this ancient material to fit modern needs. "Conductive terrazzo" is designed for safety in hospitals, especially where anesthetics are used. The other type is for indoor-outdoor installations over radiant heating or cooling systems. *National Terrazzo and Mosaic Assoc., Inc., 2000 K St., N.W., Washington, D.C.*

Concealed Door Closer

A slim aluminum overhead door closer is hidden from view and can

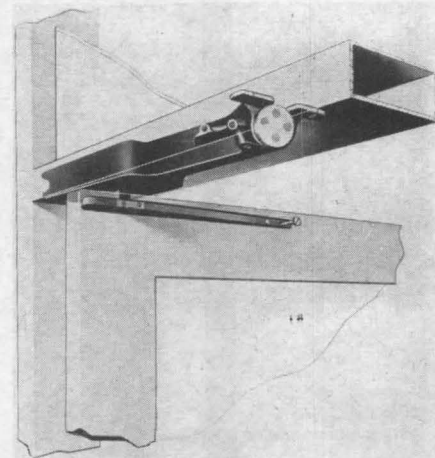

be installed in any headjamb or transom bar. Designated Model 2000, the unit is available in 90 or 105 degree preset hold-open positions as well as "no-hold-open." It can be used on single or double acting doors up to 48 in. *Beach Mfg. Co., 2000 S. Santa Fe Ave., Compton, Calif.*

more products on page 180

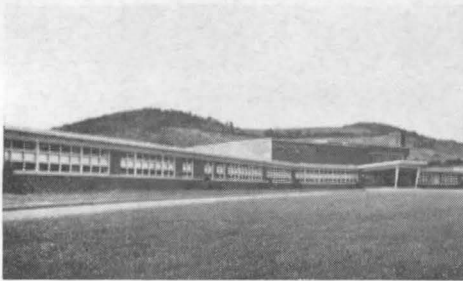

Loyalsock Township Junior High School
Williamsport, Pennsylvania
Architect: John Boodon

Ribbons of windows develop exterior character for this new school

Architect John Boodon specified Andersen Flexivents® for adequate glass area, ease of ventilation, effective insulation

Extensive bands of Andersen Flexivents help Loyalsock Township Junior High School in Williamsport, Pennsylvania function as an efficient, versatile educational plant.

These Flexivents are stacked three high to provide all the natural illumination desired. They open to almost 90°—quickly and easily—to bring in desired ventilation, even in a rain storm.

On cold days Andersen Flexivents save on heating bills. They have the natural insulating qualities of wood—plus weathertightness that is 5 times industry standards. With the amount of glass area in a school this size, fuel savings can be substantial—more than enough to take care of maintenance.

Andersen Windows are available in seven different basic types: Casement, Glider, Pressure Seal, Beauty-Line, Strutwall*, Basement and Flexivent. And each of these types comes in sizes to suit any building need.

Check Sweet's File, and contact your distributor for Tracing Detail File. Andersen Windows are available from lumber and millwork dealers throughout the United States and Canada.

* TRADEMARK OF ANDERSEN CORPORATION

Andersen Windows

ANDERSEN CORPORATION • BAYPORT, MINN.



America's most wanted windows

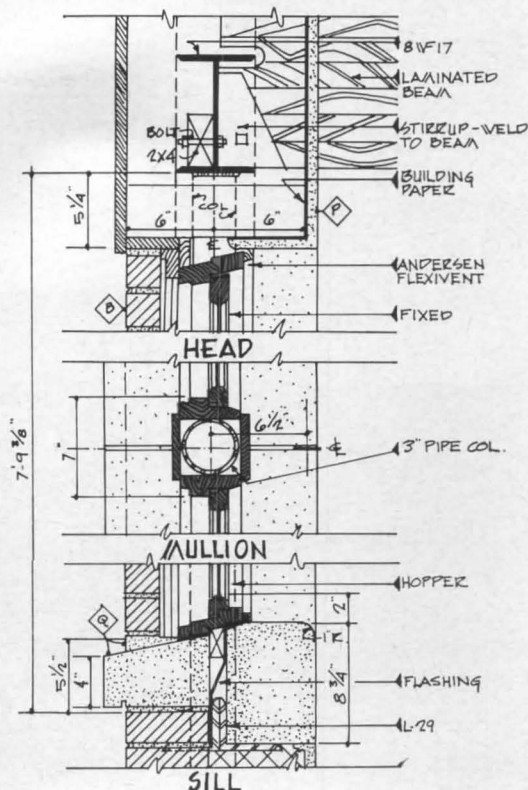

GUTH multi-mount EXITS

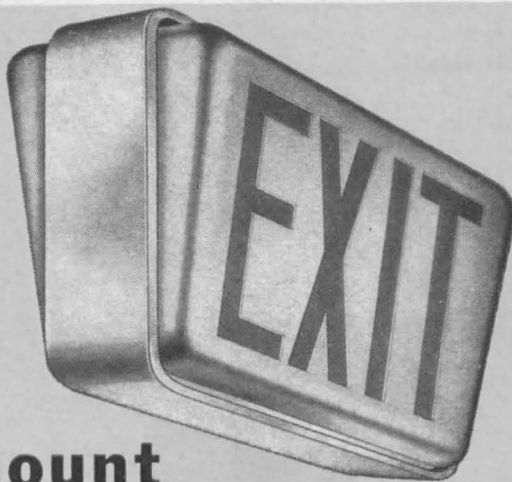

THE FIRST ALL-NEW "EXITS" ... since doors were invented!

A slight overstatement, maybe. But these Guth Exits DO introduce a lot of new ideas.

DESIGN-WISE — They're on the elegant side. A dramatic new shape with trapezoidal housing. Guth quality construction throughout. No screws to unlatch on face-plate doors. Doors lift up and swing open for easy servicing. The face slants to point directly at the natural "line of sight."

THREE LAMP SOURCES — Your choice of Incandescent, Fluorescent or those new, right-out-of-the future Electroluminescent panels.

FIVE MOUNTINGS — Whatever you prefer! Drawings below show complete selection.



Top Mounted



Surface Mounted



Recess Mounted



End Mounted



Triangular

One piece, die-formed, hinged Face Plates: All glass or cut out metal letters with glass behind.

ASK FOR COMPLETE NEW "EXIT" CATALOG

I. B. E. W.
Union made
and wired



brascolite

2615 Washington Blvd., Box 7079, St. Louis 77, Mo.

Product Reports

continued from page 176

Epoxy Mortar

A thinline epoxy mortar has great strength and ability to bond any masonry substance. Twelve lb of *Multi Mortar* is supposed to do the work of 800 lb of ordinary mortar. The rapid-setting mortar is weatherproof and waterproof. *Delorme, P. O. Box 3134, Granada Hills, Calif.*

Eye-Level Refrigerators

Built-in refrigerators at eye level are part of compact kitchens designed with retirement homes in mind. Sizes



available are 8.1, 10.2 and 12.3 cu ft. The wood-construction kitchens range in width from 79 in. up to fit almost every space. *Major Line Products Co., Inc., Hoquiam, Wash.*

Plastic Shower Stall

Polyester resin reinforced with fiberglass, the same plastic used for impact-resistant boats, is used in a one-piece, prebuilt shower stall. Easily installed, the stall has walls of American Cyanamid's *Laminac* with a hard, lustrous finish which resists mildew and fungus growth. *Ceralyte Corp., Salt Lake City, Utah*

Spiral Fluorescent Lamps

Spiral design enables *Power-Twist* bulbs to produce brighter light than conventional styles. The visual effect

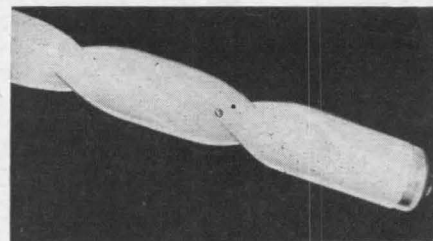

is similar to glare-reducing louvers, thus reducing fixture cost and maintenance. *Duro-Test Co., North Bergen, N. J.*

... designed to fit in anywhere!



Wall-Hung Model WL11D
Available in 8 and 11 gallon capacities.



Free Standing "Junior" Model WL7D
Available in 8 and 11 gallon capacities.



"Built-In" Model WN10
Available in 5 and 10 gallon capacities.

"WALL LINE" WATER COOLERS

MAIL COUPON NOW!

WALL LINE
WESTINGHOUSE WATER COOLERS

WESTINGHOUSE ELECTRIC CORPORATION
Water Cooler Dept., 300 Phillippi Road
Columbus 16, Ohio
Please send me 1961 Westinghouse A.I.A. Water Cooler Catalog.

NAME _____
 NAME OF COMPANY _____
 ADDRESS _____
 CITY _____ ZONE _____ STATE _____

Westinghouse

AR-12

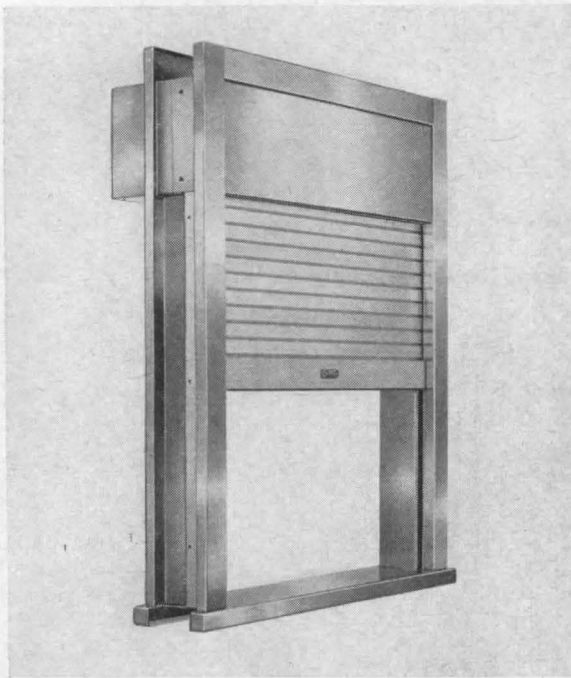

New Cookson Integral Counter Door-and-Frame Units Come in Standard Sizes, Priced 25% Less, Cost Less to Install

Full Protection Plus the Compatible Architectural Look

Long the world's largest manufacturer of custom-built counter doors, Cookson now offers architects and owners a single, completely unitized frame-and-curtain for counter openings or pass windows. A standard line of four sizes is now available, to fit wall dimensions from 4" to 10" thickness, and rough openings of 4'0" x 4'0"; 6'0" x 4'0"; 8'0" x 4'0"; and 10'0" x 4'0".

Prices are at least 25% less than custom built counter doors and frames in other sizes. In addition, the Cookson frame

can be set in place at any time during construction, at the convenience of the contractor, resulting in lower installation costs. These units are furnished with a durable Cookson Type CD8-2 "Alumilited" Counter Door Curtain, placed in a stainless steel frame with sparkling No. 4 finish. Stainless steel curtain also available.

Here is the most practical, attractive and economical answer to standard size counter door applications, for schools, cafeterias, hospitals and ticket windows. See our catalog in Sweet's or write for your personal copy: The Cookson Company, 700 Pennsylvania Ave., San Francisco 7, Calif. Sales and service in principal cities.



COOKSON

ROLLING DOORS • FIRE DOORS • GRILLES • COUNTER DOORS • COILING PARTITIONS

Office Literature

continued from page 164

Marble Anchoring System

(A.I.A. 22-A) Light-weight, weather-tight marble veneer can be anchored simply and rapidly with the Zibell system, described in a 12-page booklet which gives other specification for marble as well. *The Georgia Marble Co., 11 Pryor St., Atlanta 3, Ga.*

Buying Plywood

A free directory for purchasers and specifiers of hardwood plywood gives names and addresses of suppliers, the type of plywood each makes, types of glue bond, equipment and special items manufactured. "Where to Buy" also lists technical and promotional literature available. *Hardwood Plywood Institute, 2310 S. Walter Reed Drive, Arlington 6, Va.*

Industrial Fans

(A.I.A. 30-D1) Construction features, electrical characteristics and performance charts on Greenheck SB line of fans is given in an 8-page bulletin. *Greenheck Fan & Ventilator Corp., Schofield, Wisc.*

Sound Control

(A.I.A. 39-B) *Geocoustic*, a cellular glass acoustical unit which employs the patch technique in controlling sound, is discussed in a 12-page booklet, which includes actual job photographs and sketches. Background data on the material is included. *Pittsburgh Corning Corp., One Gateway Center, Pittsburgh 22, Penn.**

Industrial Doors for Every Use

Doors for special conditions are discussed in a collection of bulletins which give specifications for freezer, cold storage, shock absorber, humidity control, high temperature and fire doors. *Clark Door Co., 515 Hunterdon St., Newark 8, N.J.*

Roof-Top Air Conditioning

Roof-top units designed especially to heat and cool one-story buildings are described in a 24-page booklet. Each unit in the *Melco* multiple system is controlled separately to provide the right temperature for different areas. *Melchoir, Armstrong, Dessau, Inc., Ridgefield, N.J.*

** Additional product information in Sweet's Architectural File*

more literature on page 190

TUTTLE & BAILEY AIR DISTRIBUTION EQUIPMENT

has been proved in
every kind of installation

The broad range of T&B air distribution devices and accessory equipment for heating, cooling and ventilating answers every requirement of the architect, engineer and client. As the largest full-line manufacturer, T&B offers the precise piece of equipment for each job . . . setting the highest standards of appearance and performance.

Write for the name and address of the Factory Office or Sales Representative nearest you.

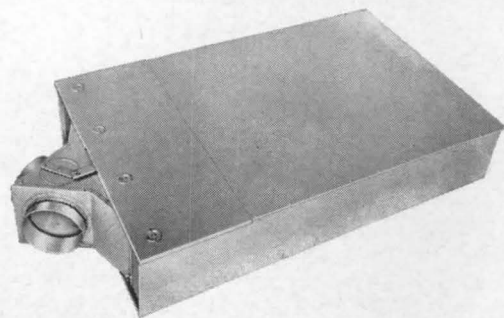
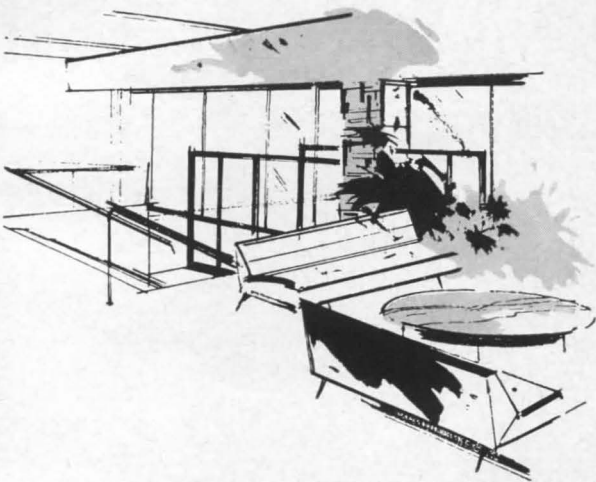
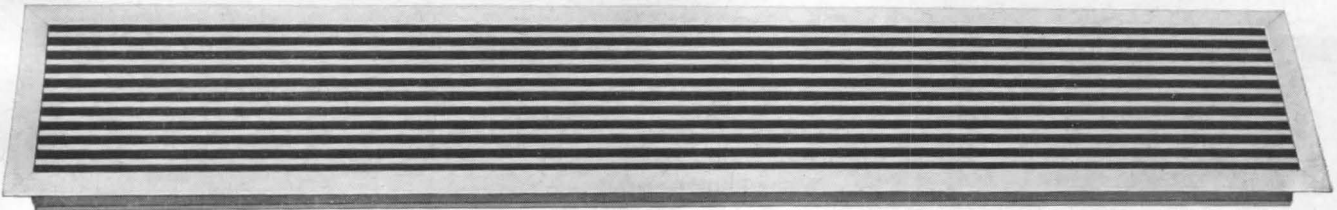
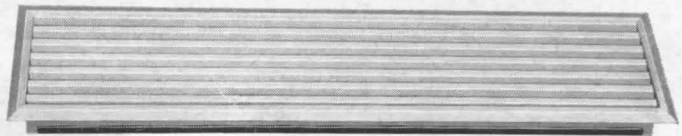
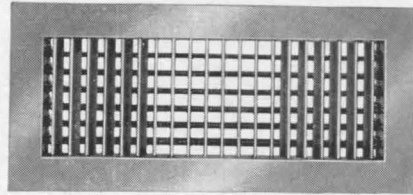
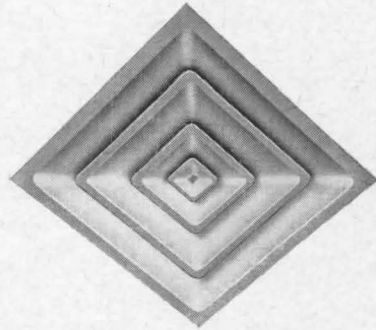
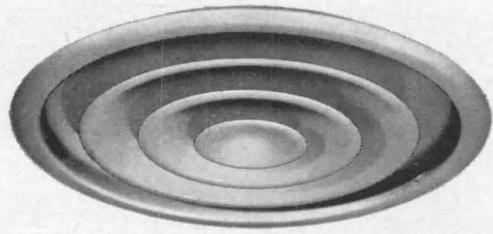

TUTTLE & BAILEY

Division of Allied Thermal Corporation
New Britain, Connecticut

Tuttle & Bailey Pacific, Inc., City of Industry, Calif.

On the Calendar

December _____

- 3-7 18th Annual National Association of Home Builders Convention-Exposition — McCormick Place, Chicago
- 5-7 Building Research Institute 1961 Fall Conferences—Shoreham Hotel, Washington, D.C.
- 14-15 Conference on soil mechanics and foundations, presented by

the University of Wisconsin Extension Division—Madison, Wis.

January _____

- 22-25 National Plant Engineering & Maintenance Show and Conference — Convention Hall, Philadelphia
- 25-27 Annual meeting, Society of Architectural Historians — Boston

- 29ff Semi-annual meeting, American Society of Heating, Refrigeration and Air-Conditioning Engineers, Inc.; through Feb. 1—Chase-Park Plaza Hotel, St. Louis, Mo.
- 29-30 17th Annual Short Course in Residential Construction, sponsored by the University of Illinois Small Homes Council-Building Research Council in cooperation with the Division of University Extension; theme: "New Methods and Materials for Better Home Building" — Champaign - Urbana campus, University of Illinois
- 30ff 18th Annual Technical Conference, sponsored by the Society of Plastics Engineers; through Feb. 2—Penn Sheraton Hotel, Pittsburgh



Hyde Park Golf and Country Club • Cincinnati
Architect: Luigi Marioni

Van helps improve flow and service...save labor at club

Growing food service establishments and their architects will find in Hyde Park Golf and Country Club's expansion convincing evidence of Van's ability to help in kitchen engineering; in design, fabrication and installation of food service equipment.

The problem: a smooth-running kitchen that can feed in several directions and operate with small crew or capacity staff after addition of dining room, new grill rooms and patio serving sandwiches and steaks.

Van kitchen engineers collaborated to accomplish the shining facilities illustrations show . . . substantially of stainless steel . . . for clean working surfaces, easy cleaning, long life. You have tough food service problems? Use Van's century of experience.

THE JOHN VAN RANGE CO., 429
Culvert St., Cincinnati 2, Ohio.



February _____

- 12-15 12th Exposition of the Air-Conditioning and Refrigeration Industry, sponsored by the Air-Conditioning and Refrigeration Institute — Great Western Exhibit Center, Los Angeles

Office Notes

Offices Opened _____

Edwin M. Stitt, A.I.A., Registered Architect, formerly with Charles Bacon Rowley & Associates, Inc., announces the opening of his office at 8528 Mentor Ave., Mentor, Ohio.

William Smull, A.I.A., has reopened his office for the general practice of architecture at 575 Madison Ave., New York 22.

Leo Kornblath Associates has opened an office at 1819 L Street N.W., Washington, D.C., the third since the architectural-interior design firm was founded a year ago. Other offices are in New York and Hato Rey, Puerto Rico.

Pasqual F. Notartomaso, Registered Architect, announces the opening of his new office at Scranton National Bank Building, Rm. 1102, Scranton 3, Pa.

New Firms, Firm Changes _____

Gerald D. Sorenson, licensed ar-
continued on page 206

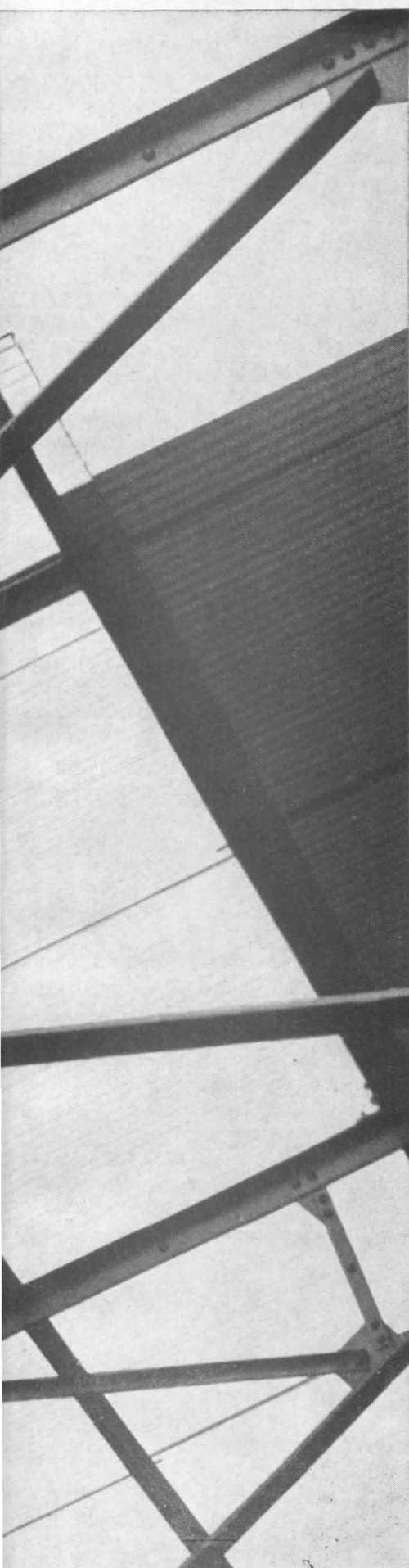

LOOK UP TO ALSYNITE

*Daylight your buildings with shatterproof Alsynite—
eliminate breakage, cut maintenance 30% to 60%*

Things start looking up—the day you start designing with Alsynite. This reinforced translucent panel offers a modern approach to daylighting plants and offices, plus some long-term advantages that mean continuing client satisfaction. Alsynite transmits only diffused glare-free light—lets you design your buildings with natural illumination that eliminates the hazards of deep shadows and glaring hot spots, while affording client savings in electricity.

Just as important—Alsynite is shatterproof! In skylights, sidelights and sash it eliminates replacement and shaves maintenance costs to effect savings of from 30% to 60%. Made in a wide variety of corrugations and shapes to nest with other standard building materials, or in flat panes to fit standard sash, or to special requirements on order. Alsynite is reinforced with millions of glass fibers, can be installed without special handling or tools.

Alsynite's own guarantee is backed by the world-wide reputation of RCI, one of the great names in chemicals. Talk over your requirements with your nearest distributor, listed in the Yellow Pages under plastic products. Or for free literature, write Alsynite, San Diego 9, Calif., Dept. AR-1261.

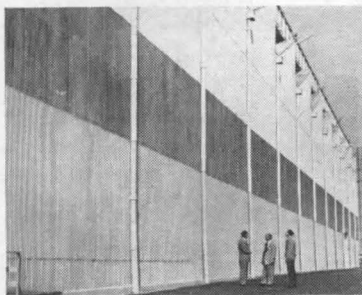

EASY TO INSTALL AND MAINTAIN!
No special handling or tools
needed. Alsynite keeps costs down!

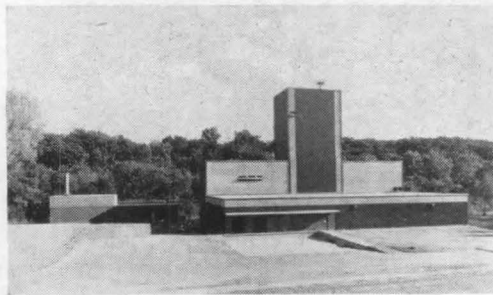

CONTEMPORARY APPEARANCE! Alsynite adds
much to the appearance of buildings like the
JFG Instant Coffee Plant, Knoxville, Tennessee.

ALSYNITE
TRANSLUCENT PANELS



A DIVISION OF REICHHOLD CHEMICALS, INC.

chitect and civil engineer, for the past six years affiliated with Brandow & Johnston, Los Angeles, has joined the staff of Burke, Kober & Nicolais, Los Angeles architectural and engineering firm.

The engineering and architectural firm of Praeger-Kavanagh-Waterbury, 126 East 38th St., New York City, has named Charles D. Morrissey to the partnership.

Mark T. Jaroszewicz, A.I.A., has joined the firm of Tarapata-Mac-

Mahon Associates, Inc., Architects and Engineers, Bloomfield Hills, Mich., as a senior designer and project administrator.

William J. Bain Jr., A.I.A., has been admitted to partnership in the firm of Naramore, Bain, Brady & Johanson, Architects and Engineers, Seattle, Wash.

Angus McCallum, a former partner in the Kansas City architectural firm of Kivett & Myers & McCallum, has returned to independent practice

with offices at 1221 Baltimore, Kansas City, Mo. Clarence Kivett and Ralph E. Myers will continue their practice as Kivett & Myers at 1016 Baltimore, Kansas City.

Following the death of Mr. Gordon M. West, in the firm of West and Switzer, Roy J. Switzer, B.Arch., M.R.A.I.C., will carry on the business under the same firm name for an indefinite period. The office has been moved to Rm. #1, Capitol Theatre Building, 2510 Yonge St., Toronto 12, Ontario.

William E. Dunlap and John R. Weese have been elected general partners in the firm of Skidmore, Owings & Merrill. Mr. Dunlap will be with the Chicago office and Mr. Weese, with the San Francisco office.

Edward J. Tedesco Associates, Architects, 15 Pleasant St., Woburn, Mass., announce the association of Emmanuel J. Rempelakis and Frank Paul Orlando.

New Addresses _____

Vincent C. Cerasi, Landscape Architect-Land Planner, 130 Lake St., White Plains, N.Y.

Waisman Ross & Associates, Architects, Engineers, Planners, 10 Donald St. N., Winnipeg 1, Manitoba.

Elections

The Industrial Designers Institute elected the following national officers for two years terms at the Board of Trustees annual meeting in Boston: chairman, John Vassos, F.I.D.I., Norwalk, Conn.; president, Leon Gordon Miller, F.I.D.I., Leon Gordon Miller Associates, Cleveland, O.; executive vice president, Jon W. Hauser, Jon W. Hauser, Inc., St. Charles, Ill.; secretary, Theodore C. Clement, Eastman Kodak Company, Rochester, N.Y.; treasurer, Yasha Heifetz, Clinton, Conn.; regional vice presidents: Joseph Parriott, F.I.D.I., Westport, Conn.; Montgomery Ferrar, Southfield, Mich.; and Donald W. Brundage, Brundage Associates, San Francisco, Calif.

Officers elected for 1962 by the Council of the Society of Plastics Engineers, Inc. are: president, James R. Lampman, manager of
continued on page 216



Autocall[®] SECURITY SYSTEM gives new AUTO PLANT advanced protection features

Ford Motor Company's modern Chicago Stamping Plant is typical of industry's trend to Autocall's advanced plant protection. Here security personnel in the control center keep their fingers on the pulse of the entire plant, maintain maximum security around the clock.

This trend-setting Autocall system includes automatic sensing devices which detect dangerous or irregular conditions and instantly transmit them into the control center. Here they are immediately printed (in plain English) on the Autocall-Howe print recorder, giving cause, location and time of the signal. All signals are positive, non-interfering and successive. If two or more signals are actuated at

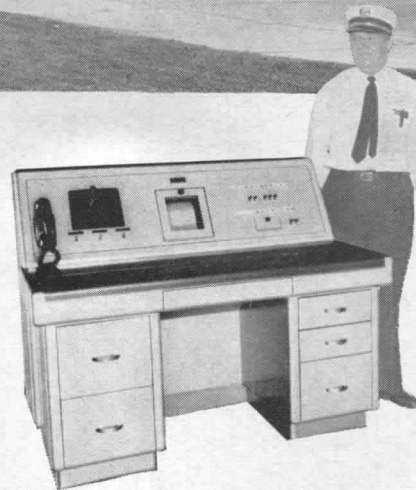

the same time, each operates in turn and none are lost. In addition the system provides patrol monitoring and two-way communication throughout the entire plant.

An efficient, cost-saving Autocall fire alarm or complete security system can be tailored to fit the requirements of your property. Get the full story. Write, wire or phone now!

Autocall[®]

FIRST IN PROPERTY PROTECTION

THE AUTOCALL COMPANY • SHELBY I, OHIO • SALES OFFICES IN PRINCIPAL CITIES

PPG SOLARGRAY® Plate Glass pays big dividends in new Harris Bank Building

MORE than an acre of PPG SOLARGRAY Polished Plate Glass is at work in the Harris Trust and Savings Bank Building in Chicago. Combining utility with beauty, PPG SOLARGRAY truly is "at work."

PPG SOLARGRAY is contributing to interior comfort in the Harris Bank Building because it is a heat-absorbing and glare-reducing plate glass. Its soft gray tint absorbs about 50% of the sun's heat and substantially reduces the amount of sun glare entering the building. Yet it permits plenty of light to come through, allowing a proper balance of natural and artificial lighting. And SOLARGRAY provides this glare-and heat-control with a neutral gray tint that requires no special interior color planning.

While SOLARGRAY was developed to control the sun's heat and glare, its delicate color adds beauty to any building. The use of PPG SOLARGRAY Plate Glass in the Harris Bank Building helps give the building its distinctive beauty.

Other PPG Glass Products in the building include 1/2" clear Polished Plate Glass and, for accent, white suede finish PPG CARRARA® Structural Glass that will retain its color and beauty permanently. Your Pittsburgh Plate Glass architectural representative will give you specific data on any PPG product. For a quick look, check the Pittsburgh Glass Products Catalog in Sweet's.

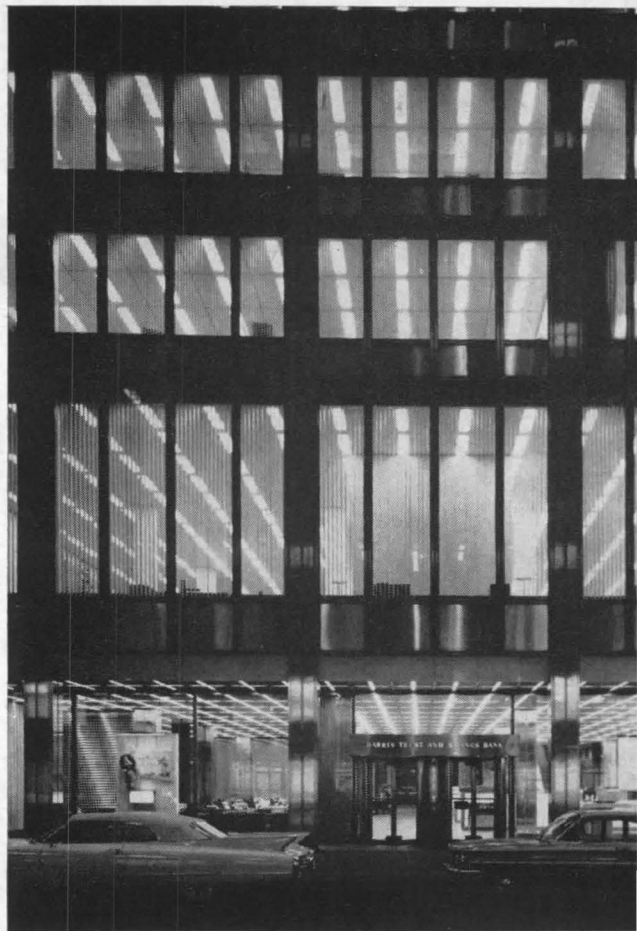

Architects-Engineers: Skidmore, Owings & Merrill, Chicago, Ill.
Contractor: Turner Construction Co.
Glazed by: Hooker Glass and Paint Manufacturing Company



PITTSBURGH PLATE GLASS COMPANY

Paints • Glass • Chemicals • Fiber Glass

In Canada: Canadian Pittsburgh Industries Limited

PPG SOLARGRAY Polished Plate Glass does double duty in The Harris Trust and Savings Bank Building. It reduces glare and heat . . . and provides distinctive beauty.

General Electric Company's Organic Chemical Engineering Materials and Process Laboratory, Syracuse, N.Y.; vice president, engineering, John M. Berutich, sales engineer, Haveg Industries, Inc., Louisville, Ky.; vice president, administration, Richard B. Bishop, consultant and research associate, Holy Cross College, Worcester, Mass.; secretary, George P. Kovach, manager, Product Development, Foster Grant Co., Inc., Leominster, Mass.; and treasurer,

Samuel H. Greenwood Jr., sales manager, Press Div., F. J. Stokes Corp., Philadelphia, Pa.

Education Notes

Eight new instructors joined the University of Detroit's Department of Architecture this semester. They are: Louis F. Michel, Ann Arbor; Robert Camblin, Detroit; Barry N. Merenoff, Royal Oak; Mark T. Jaroszewicz, Birmingham; John W.

Plasko, Detroit; Jens J. Plum, Detroit; Morris A. Lifshay, Oak Park; and Denis C. Schmiedeke, Plymouth.

Edward H. Lyons was recently appointed supervisor of cooperative training for the University of Detroit College of Engineering and Architecture.

Martin L. Beck, F.A.I.A., practicing architect and president of the New Jersey State Board of Architects, has been named to the newly created post of director of planning and supervising architect of New York University.

Charles W. Harris has been appointed associate professor of landscape architecture for two years, effective Feb. 1, 1962, at the Harvard Graduate School of Design. At present Mr. Harris is in Italy as Chief of the Landscape Section in the Rome Office of the Architects' Collaborative International, Ltd., in the building of the University of Baghdad.

The following new appointments to the faculty for the 1961-62 scholastic year have been made in the Department of Architecture, University of Notre Dame: Julian E. Kulski, architect and city planner, a member of the A.I.A., American Society of Planning Officials, American Institute of Planners; Kenneth A. Featherstone, architect and design consultant, a member of the R.I.B.A.; Solomon J. Lim, with professional experience in architectural design, drafting, specification writing and supervision.

Soil Mechanics Conference To Be Held at Wisconsin U.

A conference on soil mechanics and foundations will be presented by the University of Wisconsin Extension Division, Madison, Wis., on Dec. 14 and 15. In a program designed for the practicing architect and structural engineer, guest lecturers will include: William G. Murphy, associate professor of Theoretical and Applied Mechanics, Marquette University; Ralph B. Peck, professor of Foundation Engineering, University of Illinois; B. K. Hough, consulting engineer, Soils and Foundation Engineering, Ithaca, N.Y.; and Don U. Deere, professor of Civil Engineering and Geology, University of Illinois.

What is a dumb waiter?



... probably the most industrious worker in multiple-floor buildings!



here's why... A dumb waiter lifts vertically loads of every description between floors faster and easier than any other method of transportation — just by pushing a button. It reduces work loads, saves valuable man hours and increases overall efficiency.

To stand the use and abuse that it must, a dumb waiter must be carefully and soundly engineered. Emphasis should be on safety, sturdiness, heavy duty construction and most important — dependability.

You can protect your clients by specifications that will in-

sure this dependable service. Let Sedgwick study your lifting problem, make recommendations, submit suggested specifications and prepare preliminary sketches of hoistway requirements. This is a free consultation service based on Sedgwick specialized experience since 1893.



See standard specifications and layouts in SWEETS 24a/Se

Sedgwick MACHINE WORKS

142 WEST 15TH ST., NEW YORK 11
NATIONWIDE REPRESENTATION

Impact and fire resistance are twin features of this Polished Misco Wire Glass installation in Tennessee School for the Deaf, Knoxville, Tenn. Architect—Painter, Weeks & McCarty, Knoxville, Tenn.

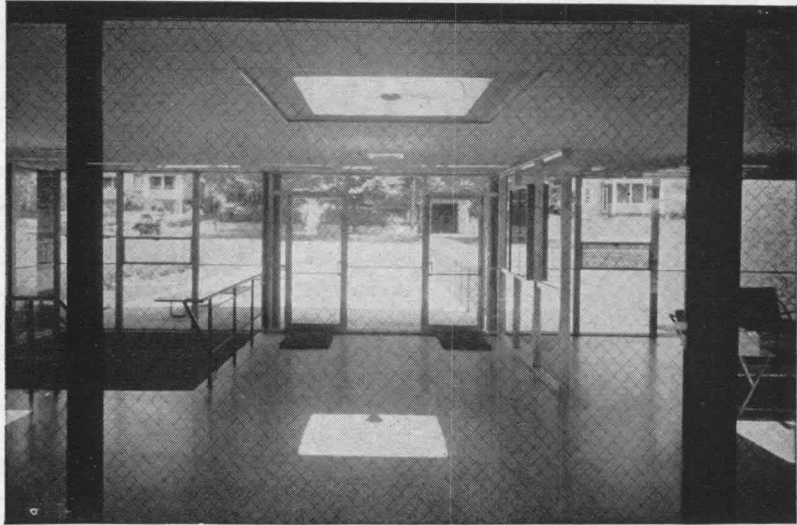

MISSISSIPPI GLASS . . .

LEADS THE WAY IN

Daylighting

WITH SAFETY

Combining beauty, utility, and economy, Mississippi leads the way by making available an extensive selection of translucent glass patterns that do wonderful things with daylight. In addition, rugged Mississippi Wire Glass, whether for obscurity or clear vision, affords effective but inconspicuous fire protection while enhancing the appearance of any structure . . . when installed in partitions, skylights, airwells, windows, doors, or wherever else fire and breakage protection is required. The versatility of Mississippi glass provides architects and engineers with a practical solution to virtually every daylighting problem, including safety with decoration, with heat absorption and with light diffusion and direction.

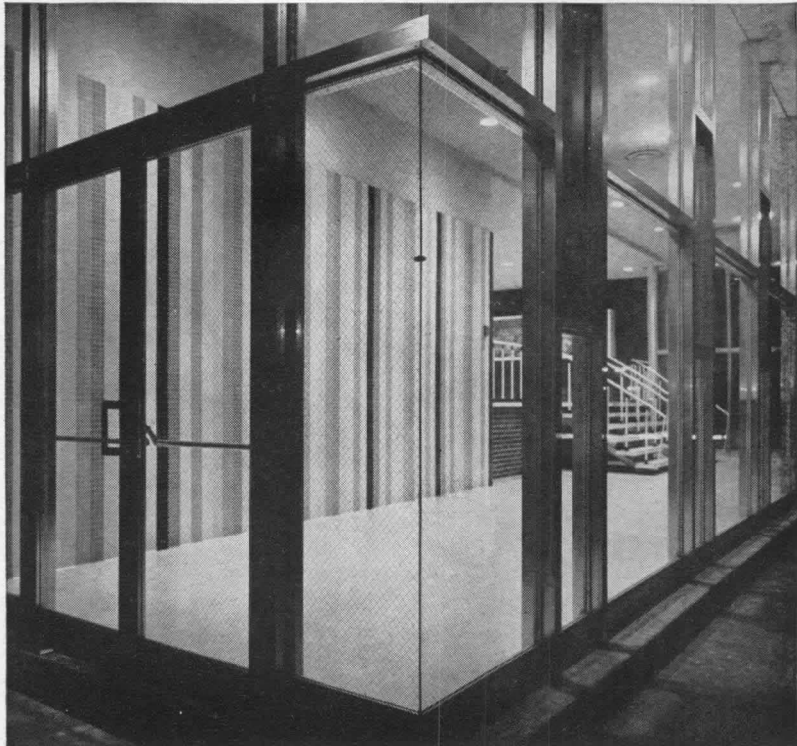

Polished Misco Wire Glass glazed in main entrance of Hellertown High School, Hellertown, Pa. Architect—Heyl, Bond & Miller, Allentown, Pa. Contractor—Gottlieb-Schneider, Bethlehem, Pa. Glazing Contractor—Penn Allen Glass Company, Allentown, Pa.

MISSISSIPPI GLASS COMPANY

NEW YORK • CHICAGO • FULLERTON, CALIFORNIA

38 Angelica Street • St. Louis 7, Missouri

MANUFACTURER OF ROLLED, FIGURED AND WIRED GLASS

**SPECIFY THE
FLOOR FINISH
THAT CAN TAKE
A POUNDING . . .
SEAL-O-SAN®**



Clients appreciate the way Seal-O-San protects their expensive gym floors. This floor finish exposes, yet protects, the natural beauty of the wood. Even the annual rat-a-tat-tat of thousands of basketballs can't erase Seal-O-San protected beauty. This is a hard-nosed floor finish that shrugs off the pounding of gym shoes, street shoes, even roller skates and bridge table legs. So protect your reputation for creating stay-beautiful buildings. Specify Seal-O-San. And send for our free Gym Floor Manual. It answers all important questions about gym floor care.



See our insert in Sweet's Catalog, 13 M/Hu



HUNTINGTON LABORATORIES
HUNTINGTON, INDIANA
Philadelphia 35, Pennsylvania In Canada: Toronto 2, Ontario
HUNTINGTON
... where research leads to better products

Letters

continued from page 10

getting fed-up with this attitude.

The art in fine architecture grows as much out of good engineering as from purely an artistic approach. If this were not true any artist might as well practice architecture. This in no way underrates the importance of either of these phases and does not exclude the many other social, economic or environmental factors that must play their roles if true "Architecture" is to be achieved. If Pier Nervi, educated primarily as an engineer, can create some of the world's most magnificent and original architecture, there is every reason to believe that properly trained architectural engineers will also become leading practitioners in architectural design if they are given good architectural courses during their education.

At the present time Pennsylvania State University is in the process of making major revisions to the architectural engineering curriculum. As has been mentioned earlier in this letter, I have been fighting changes made during the past ten years. These unfortunate changes have been primarily changes in the timing of courses. All architectural design courses are completed during the first three years of the five year curriculum. This has made it virtually impossible for any of the graduates to pursue an active career in architecture for they have completed all their architectural design before they have had an opportunity to learn any engineering and, during those final two years they have forgotten much of the fragmentary architectural design courses they were given.

When I, and most of the other architectural engineering graduates in our group took this course we had architectural design courses up to the day of graduation and at that time it was only a four-year course.

Our group believes you can be of great help to the "building" profession if you will carry on with the thought provoking questions you have raised in this article. We A.E. graduates are so few, it is imperative that we get all the help we can from those who agree with us.

*Nathan Cronheim
Cronheim & Weger
Philadelphia*

**Just Out!
ARCHITECTURE
TODAY & TOMORROW**

By **CRANSTON JONES**
Associate Editor, *Time*

Based almost entirely on direct interviews, this volume presents the world's major 20th century architects in a strikingly illustrated series of profiles. Here is a vivid photographic synopsis of the world's architecture . . . from the pioneering efforts of Sullivan to the gleaming cities of Le Corbusier. Here too, the ideas and convictions of the 20th century's major architects are dramatically unfolded . . . putting you in direct visual contact with modern building problems and their exciting solutions. 256 pp., 340 black & white illus., 53 color plates, \$17.50

**10 Days'
FREE
Examination**

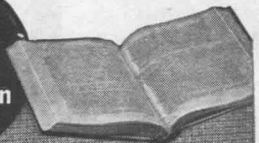

PILE FOUNDATIONS

Theory, Design, Practice

Revised 2nd Edition. Gives you valuable data and practical techniques for designing, installing, and maintaining pile foundations. It fully treats each essential phase, from essential concepts to in-the-field techniques. Includes newer uses for piles, cone-penetration, vane-shear tests, relative merits of hammers. By Robert D. Chellis, Stone & Webster Eng. Corp. 704 pp., 234 illus., 59 tables, \$16.00

FLUORESCENT LIGHTING MANUAL

3rd Edition. Clearly shows how to design, install, and service fluorescent lighting systems. Here, you'll find the principles and procedures you need for calculating illuminating requirements. Covers design, practical maintenance & repair, lighting economics, cost factors, color, ballasts and starters. By Charles L. Amick, Day-Brite Lighting, Inc. 393 pp., 226 illus., 66 tables, \$12.50

**STRUCTURAL ENGINEERING For
PROFESSIONAL ENGINEERS'
EXAMINATIONS**

Just Out. Avoid trial and error. This book prepares you for—and helps you pass—the examinations for professional engineer. Here are the problems you find in exams, and their time-saving solutions. Clearly explains basic concepts. Valuable as a "refresher" guide too. By Max Kurtz, Consulting Engineer. 341 pp., 246 illus., \$9.00

Free Examination Coupon

McGraw-Hill Book Co., Dept. ARR-12
327 W. 41st St., N.Y.C. 36

Send me book(s) checked below for 10 days' examination on approval. In 10 days I will remit for book(s) I keep plus few cents for delivery costs, and return unwanted book(s) postpaid. (We pay delivery costs if you remit with this coupon—same return privilege.)

- Jones—Arch., Today & Tomorrow—\$17.50
- Chellis—Pile Foundations—\$16.00
- Amick—Fluor. Lighting Manual—\$12.50
- Kurtz—Struc. Eng. For P.E. Exams—\$9.00

(PRINT)
Name
Address
City Zone State
Company
Position

For price and terms outside U.S., write McGraw-Hill Int'l., N. Y. C. ARR-12

Planning a Reinforced Concrete System? Figure Granco Cofar...

fast... proven... economical

HERE IS CONSTRUCTION SPEED.

As soon as the men (see photograph) place Cofar units they are providing:

1. Positive and temperature reinforcing
2. Form for wet concrete
3. Working deck during construction.

Cofar goes down fast. No wood forms. No bottom rebars. No temporary safety staging. Work stays on schedule. Less supervision and inspection.

CONVENTIONAL SLAB VS. COFAR SLAB

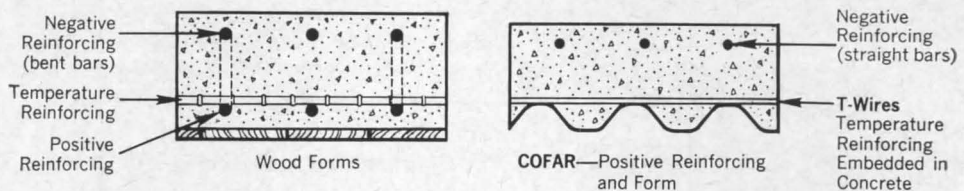

HERE IS DESIGN FLEXIBILITY.

One system satisfies a variety of load and span conditions throughout the entire building. One design procedure. Simplified drawings. With Cofar, T-wires welded across corrugations of the high-strength galvanized steel units assure horizontal shear transfer from concrete to steel. The T-wires are **embedded** in concrete. Cofar slabs are designed in accordance with A.C.I. principles for reinforced concrete. Conventional formulas apply. Cofar is the time-tested and job-proven reinforced concrete system: fire tested (up to 4-hour UL fire ratings), structurally tested (for static, repeated, concentrated and diaphragm loads). Best insurance rates available. Specify Granco Cofar with confidence—save time and money every step of the way. You get fast, dependable delivery of Cofar and helpful field service. Over 100 Granco distributors throughout the U. S.

COFAR

COMBINED FORM AND REINFORCEMENT FOR CONCRETE

GRANCO



TUFCOR® • CORRUFORM® • COFAR®
E/R COFAR® • ROOF DECK • UTILITY DECK
GRANCO VIN-COR • S-I-P BRIDGE FORMS®
PAVEMENT JOINTS • FREE FLOW SUBDRAIN



Our catalogs are filed in Sweet's!

GRANCO STEEL PRODUCTS CO., 6506 N. Broadway, St. Louis 15, Mo. A Subsidiary of Granite City Steel Company

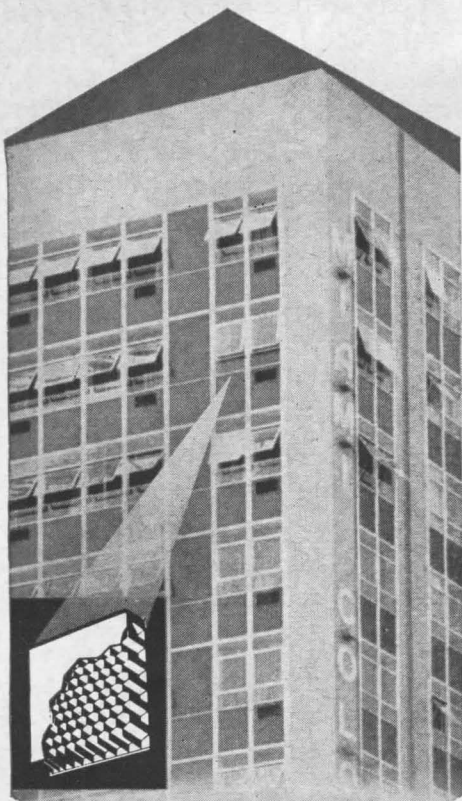

UNION HONEYCOMB in BUILDING PANELS

Kraft paper HONEYCOMB cores can be bonded to any facing material . . . serve many structural needs . . . weigh only $\frac{3}{4}$ to $2\frac{1}{4}$ pounds a cubic foot! Light-weight panels save shipping and handling costs. Simplicity of design minimizes fabrication, speeds curtainwall erection. HONEYCOMB "sandwiches" combat moisture, temperature extremes and years of weathering.

Write for free brochure describing UNION HONEYCOMB and how it is being used.

UNION-CAMP HONEYCOMB

Union Bag-Camp Paper Corporation
233 Broadway, N. Y. 7, N. Y., Dept. 86

Saarinen Memorial

continued from page 30

Let us hear now the wisdom of the man himself, spoken out of his heart to us for our profit and use, words which ruled his life, and might well shape ours:

It is on the individual, his sensitivities and understanding, that our whole success or failure rests. He must recognize that this is a new kind of civilization in which the artist will be used in a new and different way. The neat categories of bygone days do not hold true any longer. His job requires a curious combination of intuition and crust. He must be sensitive and adaptable to trends and needs; he must be part of and understand our civilization. At the same time, he is not just a mirror; he is also a co-creator and must have the strength and urge to produce form, not compromise.

Architecture is not just to fulfill man's need for shelter, but also to fulfill man's belief in the nobility of his existence on earth. Our architecture is too humble. It should be prouder, more aggressive, much richer and larger than we see it today. I would like to do my part in expanding that richness.

I think of architecture as the total of man's man-made physical surroundings. The only thing I leave out is nature. You might say it is the man-made nature. Now this is not exactly the dictionary definition of architecture which deals with the technique of building, but this is mine. It is the total of everything we have around us, starting from the largest city plan, includes the streets we drive on and its telephone poles and signs, down to the building and house we work and live in and does not end until we consider the chair we sit in and the ash tray we dump our pipe in. It is true the architect practices only on a narrow segment of this wide keyboard, but that is just a matter of historical accident. The total scope of the job is much wider than what he staked his claim on. So to the question, what is the scope of architecture? I would answer: it is

continued on page 240

UNIQUE SOUND SYSTEM design by



Exclusive New 30-Watt IN-WALL AMPLIFIER

permits inconspicuous, space-saving mounting for any permanently installed Sound System . . . no longer any need to specify an amplifier on an open shelf

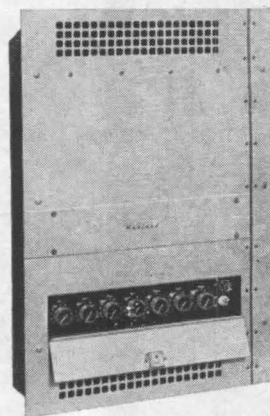

MODEL 2030

NEW FLUSH DESIGN

Installs flush in frame or masonry wall; only 4" depth required. Entire amplifier is mounted on heavy-aluminum hinged door for easy servicing. Controls are accessible through key-locking hinged front panel. Backbox has $\frac{3}{4}$ " knockouts.



Control Panel
Locked

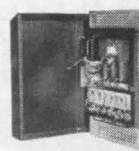

Amplifier Swings
Out for Service

ALL-TRANSISTOR AMPLIFIER

Advanced audio circuit uses 12 transistors and a Zener Diode; no tubes; 4 low impedance microphone inputs are provided for full 30 watts of clean, crisp audio power. Ruggedly designed and built; well-ventilated for continuous 24-hour operation.

This brilliant new amplifier design is ideal for use in auditoriums (mounted to rear of audience), for gymnasiums, or wherever a permanently installed sound system is desired.

ASK FOR Specification Sheet giving detailed description of the Model 2030 In-Wall Amplifier.



RAULAND-BORG CORPORATION

3535-R Addison St., Chicago 18, Illinois