

# ARCHITECTURAL RECORD

## DESIGN VANGUARD 2007

10 Winning Firms  
Chart Brave New Worlds

ALSO **PRODUCT REPORTS**

Presenting this year's  
outstanding products



**CEILING** SYSTEMS

[Between us, ideas become reality.]<sup>®</sup>

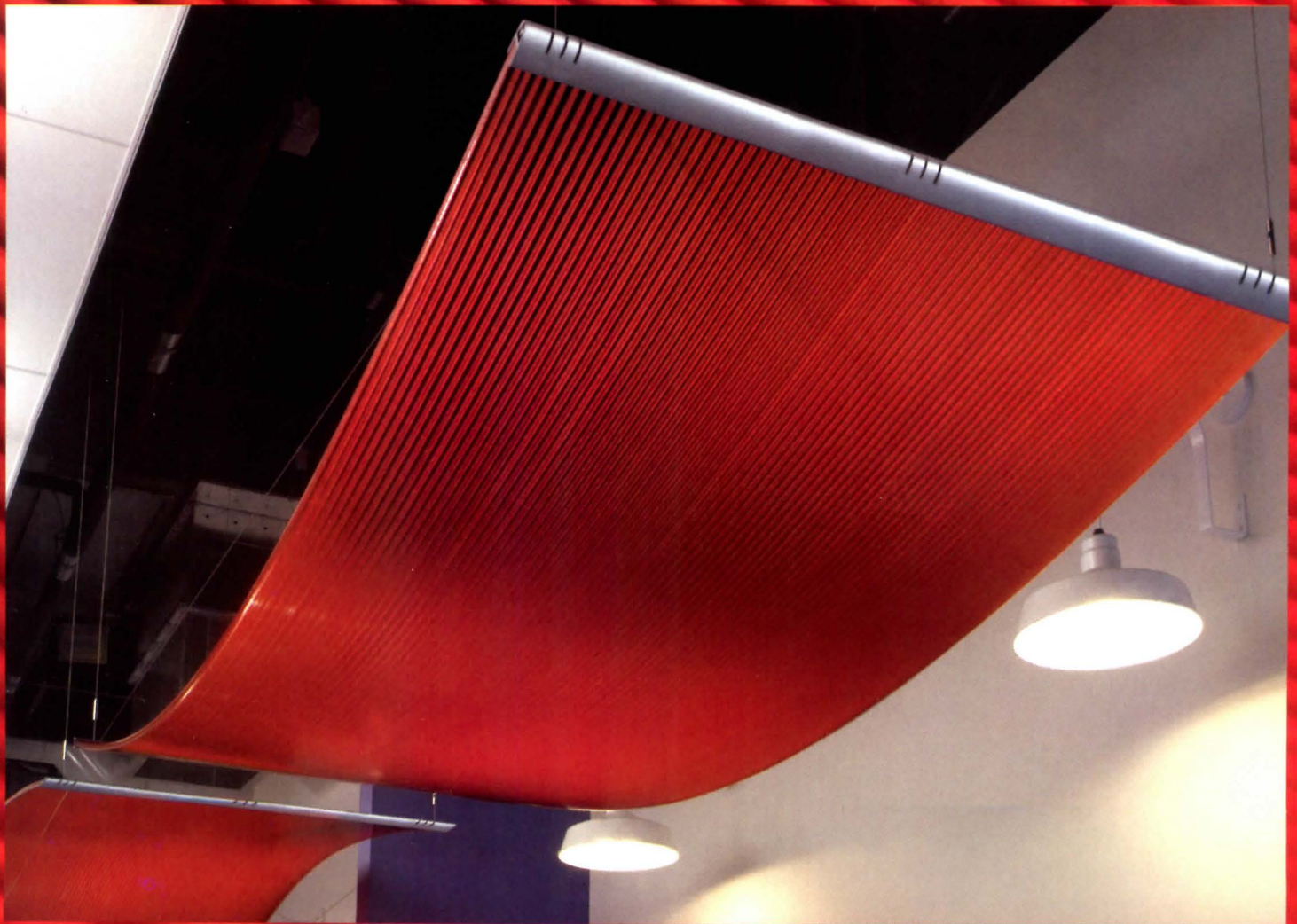

Infusions<sup>®</sup> Accent Canopies, 4' x 10', Channeled Fire





# Shifts in the architectural climate

## Editorial

By Robert Ivy, FAIA

**B**uildings play a role in an overarching problem facing all humankind. “If there’s no action before 2012, that’s too late. What we do in the next two to three years will determine our future.” Rajendra Pachauri, the economist/scientist heading the Nobel Prize-winning United Nations Intergovernmental Panel on Climate Change, speaking of his committee’s summary findings issued by Secretary General Ban Ki-moon on November 17, underscored the seriousness of our common challenge in *The New York Times*. The economy, health, even war pale by comparison to the stresses of rising pressure to our planet’s ecosystem.

The “Summary for Policymakers of the Synthesis Report of the IPCC Fourth Assessment Report” should be required reading for all architects. Consider a few of its sobering findings, all backed by international scientific consensus:

- Warming of the climate system is unequivocal, as is now evident from observation of increases of global average air and ocean temperatures, widespread melting of snow and ice, and rising global average sea level.

- Observations from all continents and most oceans shows that many natural systems are being affected by regional climate changes, particularly temperature increases.

- Most of the observed increase in globally averaged temperatures since the mid-20th century is very likely due to the observed increase in anthropogenic greenhouse gas (GHG) concentrations. [Editor’s Note: Rising temperatures are “very likely” due to human intervention.]

- There is high agreement and much evidence that with current climate-change mitigation policies and related sustainable-development practices, global GHG emissions will continue to grow over the next few decades.

- Continued GHG emissions at or above current rates would cause further warming and induce many changes in the global climate system during the 21st century that would very likely be larger than those observed during the 20th century.

The report specifically addresses buildings and their effects on the environment, recommending “key mitigation technologies and practices currently commercially available.” The short and simplistic list will be familiar to design professionals, including, among other suggestions, “efficient lighting and daylighting, more efficient electrical applications and heating and cooling devices.” Both LEED-certified professionals and ordinary architects could enumerate many more.

The positive message, embedded within the larger report, states the following: “There is high confidence that neither adaptation nor mitigation alone can avoid all climate change impacts; however, they can complement each other and together can significantly reduce the risks of climate change.” As we know

from documents such as the AIA’s white paper on “Architects and Climate Change,” buildings remain the single largest contributors to climate change, both in emissions and energy consumption. More efficient buildings only make sense, now with increasing urgency.

At the same time that our world faces its greatest test, this publication and the global architectural media, with few exceptions, have celebrated architecture that ignores sustainable design. Hardly an issue of *ARCHITECTURAL RECORD*, or our fellow publications around the globe, fails to lavish pages and praise on buildings that hog energy; ignore variability of latitude or geographic placement and of social customs or shared lessons from diverse cultures; that exuberantly preen and strut to establish their own personalities and celebrity. We include the buildings of our own nation, the world’s largest source of greenhouse-gas emissions, as well as China, the second-largest, on the list. As the critic Peter Davey proclaimed at the recent Monterey Design Conference, too often we have wallowed in formalism for its own sake, at the expense of the environment.

What can we do about this extreme situation? First, categorically, we do not denigrate the art of architecture. Our lives are devoted to the joy of its evolution and dissemination. However, we recognize the peril of the moment and the folly of uncritical presentation, including buildings in the Middle East, for example, that blithely ignore the omnipresent sun.

Our first steps may seem modest. Beginning in April 2007, *ARCHITECTURAL RECORD* will feature sustainable houses in its signatory Record Houses issue. For the first time in decades, suitability will trump aesthetics, although we hope that featured architects manage to synthesize the two. And while we may not present performance characteristics with the rigor we can muster in our case-study-based publication *GreenSource*, *RECORD* will present performance characteristics for all subsequent projects, pointing out where and when architects have met the basic challenges. When we lack real data, we will substitute our own observations and evaluations, but no project will go unremarked.

“What we need is a new ethic in which every person changes lifestyle, attitude, and behavior,” says Achim Steiner, the leader of the United Nations Environment Program. *ARCHITECTURAL RECORD*, and the profession of architecture, agree. We will do our part. Will you do yours?

To view a more complete version of the United Nations summary report, go to [http://www.ipcc.ch/pdf/assessment-report/ar4/syr/ar4\\_syr\\_spm.pdf](http://www.ipcc.ch/pdf/assessment-report/ar4/syr/ar4_syr_spm.pdf).



# CHECK OUT THIS ULTRAMODERN LIBRARY BUILDING, CLAD WITH ALPOLIC.

ALPOLIC IS PROUD TO LEAD THE INDUSTRY IN INCORPORATING ADVANCED FIRE RESISTANT TECHNOLOGY, WHICH COMPLIES WITH FIRE CODES WORLD-WIDE, AS STANDARD IN ALL OUR EXTERNAL CLADDING MATERIALS.

*PROJECT: National Library Board, Singapore*  
*ARCHITECT: T.R. Hamzah & Yeang*  
*FABRICATOR/INSTALLER: Permasteelisa Group*  
*PRODUCT: ALPOLIC/fr, custom white solid color*



**ALPOLIC<sup>®</sup>**  
**MATERIALS**

Mitsubishi Chemical FP America, Inc.

innovation • style • performance

You can't judge a book by its cover. But a lot of people are judging this world-class library building by its Alpolic-clad exterior – and raving. Alpolic's light weight, flexibility and selection of beautiful finishes and surfaces have made it a leading fabricating material for landmark public structures all over the world. And because it's backed by Mitsubishi Chemical, Alpolic is sure to stand the test of time and become a classic. One look at a building like this one speaks volumes about the benefits and beauty of Alpolic. For more information, CALL 1-800-422-7270 OR VISIT US AT [WWW.ALPOLIC-USA.COM](http://WWW.ALPOLIC-USA.COM).



CIRCLE 14 ON READER SERVICE CARD OR GO TO [ARCHRECORD.CONSTRUCTION.COM/PRODUCTS/](http://ARCHRECORD.CONSTRUCTION.COM/PRODUCTS/)



# Letters

## Long arm of the law

To self-certify or not is *not* the right question that should have been posed in Dorian Davis's article [November 2007, Record News, page 47]. The real question is whether the new state law should allow a local government to prevent an architect from filing building plans—thereby essentially limiting the ability to practice.

The new law would allow the New York City Commissioner of Buildings to sanction architects if, in the opinion of the commissioner, the professional has knowingly filed a false document. This shift in the authority to regulate a licensed professional's practice, from the state licensing board to a local government, is terrible public policy.

The law is not only solely linked to plans that are professionally certified, but also applies to any plans filed by an architect. If the professional certification process is being abused, the commissioner already has the right to suspend its use by a professional.

The AIA certainly abides by local and state laws and supports the ethical practice of the profession. For those who do otherwise, there is already a procedure within the State Department of Education that can result in revocation of an architect's license. The Department of Buildings, however, has rarely utilized that procedure.

As bad as this is, it could get worse. If other local governments obtain similar legislation, the rules governing the practice of architecture will vary in each municipality, thereby creating chaos within the profession, with no benefit to the public.

—Russell A. Davidson, AIA  
AIA New York State President 2007  
—Paul Mendelsohn  
AIA National Vice President,  
Government and Community  
Relations

## Where credit's due

For close to 60 years, I have worked with some of the great architects throughout the world, and I was fortunate enough to have taught young architectural students at Yale, Harvard, Cooper Union, and elsewhere. Your November editorial [page 25] is the first I've seen that acknowledges the role of engineers in the making of successful buildings, both structurally and mechanically. While architects design and develop functional buildings that serve the user's requirements, the final design has always required changes and input from the structural and mechanical engineers. As a result of this method of operation over the years, we engineers have been trying "to educate the architects" to bring us in early in the design process, to incorporate the engineering requirements without having to make major changes for space or cost consideration. I'm happy to see that you understand the process and are encouraging your fellow architects to incorporate the engineering programs and requirements in their initial design.

—Marvin A. Mass  
Manhattan

## Architecture's naked truth

I appreciated the Critique of purely visual architecture by Robert Campell, FAIA [November 2007, page 65]. By pointing out that much new architecture is designed for only one sense (sight), he exposes an emperor who has no clothes. Or more to the point, an emperor who has clothes but no substance within. When buildings are designed primarily for exterior special effects, we miss the best part of architecture: spatial experience. When done right, architecture is a moving experience that reaches every physical sense, and when done exceptionally right, spiritual senses, as well.

If architecture is defined as

simply a thing to look at—as if our buildings were nothing but big billboards—we have sacrificed a lot of the discipline's power. The salient characteristic of great architecture is interior volume—best experienced with all the senses, engaging movement, smell, illumination, touch, and sound. Great architecture can only be hinted at in pictures, computer graphics, or exterior elevations. The real thing still requires a body equipped to enjoy all the sensations architecture has to offer.

—Michael Knorr  
Denver

## Interior designer to the core

I take issue with William Morgan's review of the book *Interior Design & Decoration* [September 2007, page 73]. What should have been a simple review of the book's topic included a bashing of the interior design profession (and yes, it *is* a profession), as well as questioning its necessity.

Morgan insinuates that designers are not needed by the golden boys of architecture. While there are plenty of architects who have a thorough knowledge of interiors and their functional and aesthetic needs, there are some who are content to wash over specific needs of building interiors in order to satisfy more general building requirements, and then fill in the interiors as an afterthought. There is much more to designing interiors than simple decoration. For example, can hospitals function well without a straightforward interior layout; a thorough wayfinding program; efficient nurses' stations; and comfortable, maintainable furnishings for patients? The profession of interior design is increasingly nuanced, distinguishing itself from the field of architecture while needing to work cohesively with it.

As for the distinction between interior architecture and architecture, the American Society of Interior

Designers (ASID) has stated its opposition to the use of the term "interior architecture" to describe interior design, in part to prevent confusion on what services each specialty is qualified to provide.

—Sarah Smith, ASID  
Milwaukee

## Getting to the point

Although honored to have my book, *The Designer's Atlas of Sustainability*, included in your Tech Briefs book-review section [October 2007, page 170], I was concerned that the reviewer seemed to miss the point of my book and of sustainable design more generally. The point is this: Sustainable design is not easy—given where we are right now. Most architects can't simply take up holistic sustainable design, if only they would. The "system" does not have sustainability as its goal, and so the cards are heavily stacked against it—despite its increasingly obvious urgency. No wonder sustainable design efforts seem to the reviewer "too disconnected and hasty." The reviewer suggests my book is unsuitable for professionals who are set in their ways. Despite the challenges, my book presents many starting points (see, for example, "10 ways to work in sustainable design" at [www.designers-atlas.net](http://www.designers-atlas.net)), and one has to ask, do we have the luxury to remain set in our ways and dump the problem on the next generation?

—Ann Thorpe  
Milton Keynes, England

## Clarification:

In addition to Antoine Predock as design architect, HOK Sport served as architect of record for the San Diego Padres Ballpark, featured as a BusinessWeek/Architectural Record Award finalist [November 2007, page 108].

Send letters to [rivy@mcgraw-hill.com](mailto:rivy@mcgraw-hill.com).



The New Standard in Water Efficiency

# SLOAN ECOS™

The World's First TRUE Dual-Flush  
Electronic Flushometer



The new Sloan ECOS™ Dual-Flush Flushometer is the first electronic valve of its kind. Offering the user the choice between reduced flush (for liquids) or full flush (for solids), the Sloan ECOS Flushometer generates ground-breaking efficiencies through innovation.

- Intuitive dual-flush operation
- Ground-breaking water efficiency
- Advanced Sloan sensor technology

For more information, go to  
[www.sloanecos.com](http://www.sloanecos.com).

*Generating Efficiency Through Technology*

**SLOAN®**

800.9.VALVE.9  
(800.982.5839) ext. 5034  
[www.sloanvalve.com](http://www.sloanvalve.com)

Patent Pending

CIRCLE 15 ON READER SERVICE CARD OR GO TO [ARCHRECORD.CONSTRUCTION.COM/PRODUCTS/](http://ARCHRECORD.CONSTRUCTION.COM/PRODUCTS/)



## Gehry, Skanska point fingers over MIT lawsuit



MIT's suit alleges that the Stata Center has developed "persistent leaks," and that ice and snow slide from the roof during winter and present a hazard.

The finger-pointing has already begun in response to a lawsuit filed by the Massachusetts Institute of Technology (MIT) against Frank Gehry's firm, Gehry Partners, and general contractor Skanska USA. The suit alleges that flaws exist in the design and construction of the \$300 million Stata Center for Computer, Information and Intelligence Sciences.

The tilting, warped 720,000-square-foot titanium-and-brick building houses labs, offices, classrooms, and meeting rooms for MIT's Computer Science and Artificial Intelligence Laboratory, the Laboratory for Information and Decision Systems, and the Department of Linguistics and Philosophy. It was completed in 2004 at a cost of \$300 million.

The suit, filed on October 31 at Suffolk Superior Court, in Boston, claims that "Gehry and Skanska committed design and construction failures on the project which caused, among other things, masonry cracking, efflorescence, and poor drainage at [Stata Center's] outdoor amphitheater; efflorescence and mold growth at

various locations on the brick exterior vertical elevations; persistent leaks at various locations throughout the building; and sliding ice and snow from the building." It alleges that "MIT has suffered considerable damage, in the form of investigatory, redesign, and remedial work, as a result of the Defendants' failures."

Although the suit does not specify an amount the university is seeking in damages, it says that MIT paid Gehry Partners \$15 million to design the center, and it claims that Gehry Partners "failed to provide design services and drawings in accordance with the applicable



standard of care."

When contacted by RECORD, both MIT and Gehry Partners declined to comment. But in a November 7 article, Gehry told *The New York Times*: "These things are complicated, and they involved a lot of people, and you never quite know where they went wrong. A building goes together with seven billion pieces of connective tissue. The chances of it getting done ever without something colliding or some misstep are small. I think the issues are fairly minor."

Skanska spokesperson Caroline Bucquet also declined to comment on the suit's specifics for RECORD, but said, "We're very dedicated to coming to a resolution to this situation."

The Stata Center lawsuit is attracting considerable attention even outside the architecture and construction community, mainly because of Gehry's name recognition, but it's hardly unique. For instance, insurer Victor O. Schinnerer/CNA reports an annual average of 15 to 20 claims per 100 policy holders among its architect clients. John Connelly, a partner at the Peabody & Arnold law firm in Boston and a cochair of the Boston Bar Association's Construction Law Committee, observes that the majority of such cases end in settlements and that many devolve into finger-pointing.

The tit-for-tat has already begun. Gehry, for instance, told *The New York Times* that, "MIT is after our insurance."

In a *Boston Globe* article on November 6, meanwhile, an anonymous executive at Skanska's Boston office blamed Gehry for problems with the project, contending that the architect ignored

warnings both from Skanska and a consulting company about the design of his amphitheater prior to its construction.

The MIT lawsuit is not Gehry's first. In July 2006, the firm settled a suit concerning cost overruns at the Walt Disney Concert Hall, in Los Angeles. And in December 2004, Gehry had agreed to sandblast parts of the Concert Hall in response to a report that found that



the building's metallic surface was producing too much glare.

Gehry designed the Stata Center to unify scattered academic departments and to encourage interaction among scientists and students. It has won many accolades and awards, including a 2005 Grand Award from the American Council of Engineering Companies. But some professors and students are less than pleased with it. *The Tech*, an MIT school newspaper, reported in May 2004 that students complained the building is too loud, complicated, and distracting, and fails to provide occupants with enough privacy.

"It's no doubt always debatable about the merits of such lawsuits," observes Richard Fitzgerald, executive director of the Boston Society of Architects. "Ideally, in the emerging age of integrated practice, there will be no more lawsuits." Sam Lubell



## Clinton keynotes Greenbuild convention

Former President Bill Clinton took the stage at the U.S. Green Building Council's sixth annual Greenbuild conference in Chicago last month and, before a crowd of 6,000 people who gathered to hear his keynote address, described the green building movement as the nation's largest economic opportunity since the country mobilized for World War II.

are doing nothing and, therefore, gaining a competitive advantage—was flawed and akin to saying that the world should just have fun until we burn the planet down. "That ensures failure," he observed.

Clinton made several references to his vice president, Al Gore, who, along with the United Nations' Intergovernmental Panel on Climate

## SUSTAINABILITY IS "PERHAPS THE MOST IMPORTANT CAUSE WE CAN BE INVOLVED IN."

"It's not going to be easy, but we have to move away from the carbon economy," Clinton said, adding that he considers green building to be "perhaps the most important cause we can be involved in today."

In a lightly political speech, Clinton talked about the failed model of the Kyoto Protocol, the need for greater international cooperation, and the efforts of his Clinton Climate Initiative to effect change throughout the world. "It's critical that we negotiate a successor to Kyoto by 2009 or 2010," Clinton said, "and we need a broader consensus on China and India." He added that the logic many people use to criticize the cost of green building—that China and India

Change, won the Nobel Peace Prize this year for raising public awareness about the environment. Noting that such efforts have succeeded in changing people's attitudes, Clinton said that the time has come to "operationalize" the change. To that end, his foundation will use more than \$5 billion in financial commitments to undertake a green retrofit program for buildings in 40 cities, beginning with a pilot project in Chicago. Clinton added, incredulously, that this sum represents a doubling of the worldwide investment in improving energy efficiency. "We don't know what we can do, because we just got started," he said. *Russell Fortmeyer*

## USGBC to revamp LEED rating system

The U.S. Green Building Council (USGBC) is planning to revamp its popular Leadership in Energy and Environmental Design Green Building Rating System (LEED) in an effort to make it more user-friendly. USGBC hopes to create, with some exceptions, one system instead of having the newly launched LEED for Homes, for example, and LEED for Commercial. It expects to roll out the new framework next fall. Another likely change is that LEED will address life-cycle analysis, something many users would welcome.

USGBC is "harmonizing and

aligning credits" across all LEED rating systems, the group says. This will make the system more "adaptive and flexible." It will still allow additional credits that need to cover existing building types. To accomplish this, USGBC is reorganizing its committee structure. The new groups will focus on technical, market, and certification committees. The market committee will identify market expansion opportunities; the technical committee will steer LEED's development; and the certification committee will ensure credits deliver on their intent across the rating system.

## AIA releases A201 document updates

The American Institute of Architects (AIA) released revisions to its A201 contract documents on November 5. These forms, the most widely used in the construction industry, define the legal relationship between building owners, architects, and contractors. The AIA first prepared them in 1887 and issues updates once a decade. The AIA also released a new owner-architect agreement.

Chief among revisions to the A201 documents is the removal of mandatory arbitration, which has been specified since the AIA's first owner-contractor agreement in 1888. Arbitration must now be selected, with mediation as the first option and litigation as the default option. Another significant revision addresses the architect's role as the initial decision maker (IDM) when disputes occur between owners and contractors. In the 1997 update of A201, the architect was defined as the IDM with final and binding authority, provided that a request for arbitration was not filed within 30 days of the decision. The AIA has since redefined the architect as the default IDM able to provide initial decisions, with these claims defined as a precedent to mediation.

Other significant changes to the A201 documents include the

introduction of a time limit on filing claims, so that action must be initiated *within the time frame* established by applicable law but no more than 10 years after completion of substantial work on a project. Also, the mutual consequential damages waiver, added in the 1997 revision and intended to prevent runaway claims, was retained, but with the elimination of a confusing word in the section that covers the preclusion of awarding liquidated damages.

The AIA also released a new owner-architect agreement called B101, which will replace the old B141 and B151 agreements. The new document lays out the architect's "basic" services during phase five: schematic design, design development, construction documents, bidding/negotiation, and construction contract administration. It defines "additional" services as those not listed as basic. In keeping with its embrace of sustainability, the AIA has added a new proviso that requires architects to discuss with owners the feasibility of incorporating green-design approaches as part of their basic services during schematic design.

Look for analysis of the new A201-2007 and B101 documents in next month's edition of RECORD.

*James Murdock*

In addition to adding life-cycle analysis to LEED, there will be credits given based on geographic region. The goal is to certify and connect design, construction and operations, and maintenance. The USGBC first offered the LEED rating system in 2000 and has steadily added new categories since. It is expected to pilot LEED for Health Care in 2008.

The USGBC also announced that it is investing \$1 million in a green-building research agenda. "The National Green Building Research Agenda challenges government, foundation, industrial, academic, and other sectors to devote the resources commensurate with the scale of the

environmental, economic, and social opportunities we face as a planet," Gail Brager, a professor at the University of California, Berkeley and chair of the USGBC research committee, said in a press release.

The group made these announcements at its sixth annual Greenbuild International Conference and Expo, in Chicago, last month. This sustainable design convention drew a record 20,500 attendees—up from 13,300 last year—and 850 exhibitors, up from 477 last year.

*Nadine M. Post*  
A version of this story first appeared in McGraw-Hill Construction's Engineering News-Record.





colorful.beautiful.efficient.  
you depend on it.  
tough.economical.lasting.  
we stand by it.



 **BASF**  
The Chemical Company

EIFS Wall Systems. Coatings. Finishes.  
Call 800-221-9255 or visit [www.finestone.cc](http://www.finestone.cc)

CIRCLE 18 ON READER SERVICE CARD OR GO TO [ARCHRECORD.CONSTRUCTION.COM/PRODUCTS/](http://ARCHRECORD.CONSTRUCTION.COM/PRODUCTS/)



## German team wins 2007 Solar Decathlon

Historically, Europe has had an edge over America when it comes to sustainable design, so perhaps it's not a surprise that students from a German school bested 19 other college and university teams in the 2007 Solar Decathlon, a biennial intercollegiate competition sponsored by the U.S. Department of Energy (DOE) to promote innovative sun-powered, energy-efficient dwellings. The University of Maryland and Santa Clara University placed second and third, respectively.

Held on the Mall in Washington, D.C., the event drew more than 120,000 visitors during its two-week run in October. In this third decathlon, organizer and founder Richard King of the DOE says that there was "more eloquent design, better use of spaces, and better integration of solar systems on the house—some of them invisible; some of them are these beautiful winglike structures."

The rectangular, oak-paneled house built by architecture students from Technische Universität



**The 2007 Solar Decathlon's top three winners: Technische Universität Darmstadt (1); University of Maryland (2); Santa Clara University (3).**

Darmstadt ranked first in four out of the 10 categories that judges use to evaluate competitors: architecture, engineering, energy use, and lighting. Its interior is based on simple symmetry. A Plexiglas-enclosed unit, which houses the kitchen, the shower, and the bathroom, forms the core. On each end of the house is a square cavity that contains integrated furniture units—one cavity is fitted with a bed, the other a seating area.

"It has a very clear parti," says

Susan Maxman, FAIA, of SMP Architects in Philadelphia, one of the judges for the architecture category. "It's an integrated, consistent house that doesn't try to do too much."

This simplicity belies engineering complexities. The house's exterior consists of four layers, each designed to retain energy. The outermost shell is made of timber shutters that incorporate photovoltaic panels. These shutters can pivot to form louvers and follow the



movement of the sun in order to maximum energy generation. Eva Zellmann, a student on the German team, explains that these technical elements were intentionally limited to the house's exterior: "We don't want to show all the technology in the rooms, because it'd be like living in the machine."

If the winning house seems more spacious than its 800 square feet, a limit mandated by the competition's rules, that's because its north-side glass wall opens onto a patio, also clad in oak panels so that it maintains continuity with the structure's facades. "The outside flows into the inside," Zellmann says. "The deck is extending outside."

The Solar Decathlon was first opened to international teams in 2005. That year, some members of the Technische Universität team competed on a team from Carnegie Mellon University. The next Solar Decathlon is scheduled for 2009, in the United States, but the Germans and other international teams might not need to cross the Atlantic Ocean to compete. The DOE has signed an agreement to host a decathlon in Spain in 2010. *Violet Law*

## Tulane learns from A Studio in the Woods

Joe and Lucianne Carmichael were thinking green even before Hurricane Katrina. As the owners of A Studio in the Woods (ASITW), an artists center southeast of New Orleans, they have lived in the bottomland hardwood forests for 30 years using minimal energy resources. They rarely use air-conditioning, even during humid Gulf Coast summers, and they always line-dry their clothes. Their goal is to provide a retreat where artists can hone their craft—and give a lesson in living with nature. "The highest guiding principal of A Studio in the Woods is the opportunity to learn," Lucianne Carmichael says.

Thinking that architecture students might also learn from ASITW's ecofriendly model, the Carmichaels



**Porches are outdoor rooms at A Studio in the Woods.**

donated their property to Tulane University in 2004 and sought student assistance in designing a new green cottage for themselves (their old house will be converted into a public center). The focus on sustainability became that much more important after the hurricane. An architecture studio led by Eean McNaughton designed a new 1,322-square-foot house, including 735

square feet of exterior porches, that will derive its energy needs from solar and geothermal sources.

While impressive prototypes for nouveau shotgun houses have been trotted out across the Gulf Coast during the past two years, the Carmichaels' small

cottage is the first in the region to participate in the U.S. Green Building Council's new LEED for Homes program. It is aiming for Platinum certification. "In fact, we hope to sell energy back to the grid through a net-metering program," says John Anderson, an ASITW board member and Mississippi-based architect who is preparing construction documents and resolv-

ing some lingering design problems.

Although the Tulane design studio is finished, ASITW's learning opportunities will continue for a smaller number of architecture students who will perform research and documentation for the organization. These students will also learn from the fund-raising process: Tulane has offered \$80,000 toward the total construction cost of \$300,000, but ASITW must still court other donors.

Anderson hopes the project's *smart design* will attract funders who want to be aligned with model construction methods. "Part of the idea of doing this is promoting the concepts and tactics for the entire region," he explains. "It's meant to be a demonstration of what you can do, not just from the building perspective, but a lifestyle one." *Diana Lind*



Linear Wall Luminaires  
for T5 HO fluorescent lamps.  
Direct or direct/indirect light distribution.



International Forum  
Gold Design Award  
Winner 2007

**BEGA** sets the standard

[www.bega-us.com](http://www.bega-us.com)  
805.684.0533

No. 149



## New Asian cities pursue sustainable design

The word “sustainable” is not often used to describe the pollution-choked cities of Asia, but the continent is poised to host a new generation of green cities that right the wrongs of industrial-era urban planning. The question “Could we do better?” motivated New York-based SHoP Architects to take on one such project, the high-tech Sector 61 node of Gurgaon, India. “We feel that if you can set a good example there, with all the building that’s about to occur, you can have a much bigger impact than designing some LEED Platinum building here in New York,” says SHoP cofounder Gregg Pasquarelli.

Sector 61 is one among a series of commissions in which internationally known designers are creating whole neighborhoods and cities to capture and direct Asia’s sudden urbanization. Other examples include the Shanghai satellite city Dongtan, designed by Arup, and the competition for a 1.6-million-square-foot eco-quarter in Singapore, recently won by Foster + Partners.

“The millions depending on Shanghai or Seoul depopulate the countryside and exceed the city’s

capacity, with only one or two cities funneling the shift,” explains Diana Balmori, principal of the New York-based firm Balmori Associates. “So the effort is to deploy this growth to some place, give this new city a reason to exist, and bring population to it.”

Balmori’s in-house studio Balmorilab also is participating in



that effort. Its design for Public Administration Town (PAT) comprises one district within the larger ring plan for Multi-Functional Administrative City (top and above), located in South Korea halfway between Seoul and Busan. President Roh Moo-hyun is establishing the city in order to transplant several government offices from the capital. Balmorilab, with Haeahn Architecture and H Associates, won the open competition to design PAT and several of its key buildings.

## Asymptote to spice up Penang’s skyline

During the 18th century, spice attracted both traders and pirates to Penang, an island harbor for ships on the Strait of Malacca in Malaysia. Now, government officials are hoping that 21st-century vanguard architecture and luxurious beachfront resorts will once again draw international visitors to the island—this time, investors and tourists. To aid in the effort, municipal authorities have tapped Asymptote Architecture to design a \$7 billion, 256-acre mixed-use complex called Penang Global City Center (PGCC).

Lise Anne Couture and Hani Rashid, principals of the

New York-based architecture firm, unveiled their design for the nearly 11-million-square-foot PGCC development in September. Their project takes the form of two sinuous, 60-story steel-and-glass-clad towers that reach skyward from a stagelike plinth. The towers will house luxury residential units and five-star hotels; the plinth will function as a public plaza and contain retail, a performing arts center, and a convention center.

“(Our project) is a harmonic assemblage of distinct historic and cultural references set against contemporary dynamics of fluidity, transformation, and flux,” Rashid says.



PGCC’s sinuous towers rise from a stagelike plinth.

Asymptote drew on Penang’s heritage of Chinese, Indian, and Arabian influences to create fenestration patterns inspired by arabesque motifs. “The towers allude to Asian mythical symbols and Islamic minarets,” he adds.

But the PGCC will also have a

high-tech, sustainable sensibility: The project aims to be carbon-neutral. A central mechanical system will utilize trigeneration, including wind turbines and a thin-film photovoltaic facade.

Penang’s government expects to begin construction in 2008

and finish by 2012, but it is facing criticism about the site’s master plan, overseen by the Parisian firm Atelier Seraji. Opponents say that the PGCC fails to provide enough affordable housing and that it will create traffic congestion. *Rebecca Ward*

The Public Administration Town district of Multi-Functional Administrative City.

Although PAT is ostensibly the city’s downtown, Balmorilab has given it a keenly anti-iconic character. Buildings, totaling roughly 9.7 million square feet, will be open to public movement and nestle into the existing topography to create a continuous roofscape. The flat plane, dotted with plants as well as photovoltaics, also expresses PAT’s commitment to sustainability. Other green features include graywater recycling, titanium-dioxide paving, and methane production from organic waste. “The city that uses living systems, rather than industrial-era systems, offers a better quality of life from day one,” Balmori says. Construction will start next summer, and the project should be largely complete within two years.

Sector 61, in Gurgaon, India, also will break ground next year. This former agricultural village is transforming into a dense corridor

of high-tech office campuses and apartment buildings as growth spills over from New Delhi. The privately developed parcel will accommodate 73,000 people and 100 buildings. Pasquarelli says that instead of deploying green technologies, the plan will stress sustainable strategies, including solar orientation and pedestrian movement. “The cost of construction in India is so much less that to purchase Western technologies throws the entire budget out of whack,” he explains, adding that good planning can reduce the carbon footprint more than technological supplements.

Whether Asia’s future cities go green thanks to technology or to more passive principles, Balmori associate and landscape design director Mark Thomann says that observers should expect “a formal approach to sustainability that’s really expressing itself.” *David Sokol*





Business & Technology Center  
California State University  
VBN Architecture  
Formawall Dimension Series  
Insulated Metal Wall Panels  
FormaBond  
Metal Composite Wall Panels

# Great Works

## The art is yours. The palette is ours.

Your project is not merely a building, but a work of art. CENTRIA can help you bring your vision to life. Our architectural metal wall systems are crafted to the highest aesthetic standard. And, with features such as Advanced Thermal Moisture Protection (ATMP®) and Cradle-to-Cradle certification, our products are just as functional as they are beautiful. CENTRIA also offers an experienced sales team and a dedicated installer network to ensure that your design is executed successfully — just as you envisioned it.

To learn more about our palette of products, call us or visit our website.

800.752.0549 | [CENTRIA.com](http://CENTRIA.com)

CIRCLE 19 ON READER SERVICE CARD OR GO TO [ARCHRECORD.CONSTRUCTION.COM/PRODUCTS/](http://ARCHRECORD.CONSTRUCTION.COM/PRODUCTS/)

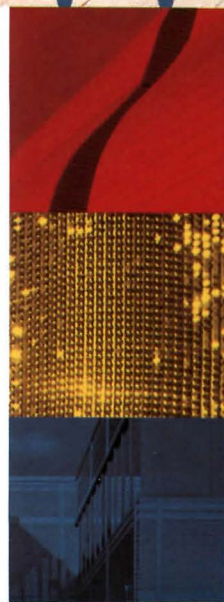

**CENTRIA**

Architectural Metal Wall  
and Roof Systems

- Formawall® Dimension Series®
- Formawall® Graphix Series™
- FormaBond®
- Concept Series®
- Profile Series



## REX marks first year

In May 2006, Joshua Prince-Ramus, then the partner in charge of Rem Koolhaas's OMA office in New York, announced that he would leave the firm to begin his own practice. With business partner and fellow OMA alumnus Erez Ella he founded REX, an acronym, with some rhetorical license, for Ramus Ella Architects. The new firm would take with it all but one of OMA's projects, along with its entire staff.

OMA has since built itself back to roughly 30 people. REX's staff numbers 45. But during its first 12 months, the young firm remained relatively quiet, fueling speculation in the press, blogs, and at cocktail

### Museum Plaza has broken ground.



parties about the goings-on there. It is finally making some noise. Among its new commissions is a headquarters for the Turkish fashion house Vakko and its sister company Power Media, in Istanbul. REX came by this project during New York's Fashion Week in March, when the client walked unsolicited into its studio and offered the firm the job. Astonishingly, the project will be executed over the span of 10 months, from its commission to the completion of construction. Using a concrete skeleton already in place for what had been a failed project by another developer, REX enclosed the structure with a glass curtain wall and, by adding a corridor at one end, converted the U-shaped plan into a box with courtyard.

REX is also busy with projects from its OMA days, including Museum Plaza, in Louisville, which broke ground in October. The design for this museum and residential complex groups six volumes, each reminiscent of a small skyscraper, into a larger, 62-story assemblage. It will cost \$465 million, and construction will be completed in 2010. Another of REX's former OMA projects, the 575-seat Dee and Charles Wyly Theatre, in Dallas, should finish in 2009. *John Gendall*



The MCA shows more than just art.

## David Adjaye's MCA/Denver opens

For much of its 11-year life, the Museum of Contemporary Art/Denver (MCA) has been overshadowed by the better-known Denver Art Museum. Most recently located in a former fish market downtown, it struggled to attract visitors despite some well-received shows. But on October 28, the museum opened its new, permanent home: a dark-gray glass box designed by the rising-star London-based architect David Adjaye; it is his first public building in the U.S.

The 27,000-square-foot structure sits on a tight corner lot in Denver's Central Platte Valley.

Adjaye, known in Europe for his creative use of industrial building materials, employed tinted glass for the exterior walls but added an interior skin of *MonoPan*, a translucent material made of woven recycled plastic and used in the fabrication of trailers and storage sheds. "It was something I encountered at a trade fair of motor cars," Adjaye says. "I was blown away by this material." The double-skin facade helps insulate the building while allowing filtered natural light to illuminate galleries.

Visitors enter the MCA through an opening in its glass exterior wall that leads to a ramp and then a glass door. Inside, there's no space-wasting atrium, though some vertical spaces reach to skylights on the ceiling. Working creatively with a budget of \$15.9 million, Adjaye created six self-contained galleries for exhibitions, with light-filled "respite corridors"—which he says are designed to give visitors time to pause before moving to the next gallery—running along the *MonoPan* walls.

Adjaye has designed a number of houses for artists and collectors, including a house adjacent to the MCA for one of the institution's board members. But for someone closely associated with art and artists, he's never before designed an art museum. He calls the MCA "incredibly significant, because the art world is something that I've been invested in." *David Hill*

## Arquitectonica hits the jackpot in Vegas

Arquitectonica's Las Vegas gamble is finally paying off with two big projects on the Strip. The Miami-based firm's \$3 billion, 2,998-room Cosmopolitan Resort & Casino is under construction on Las Vegas Boulevard, next to the Bellagio. Its design calls for two 600-foot-tall, twisting blue-glass towers perched atop a four-level, 100-foot-tall podium. These 52-story, prism-shaped high-rises are wrapped in fretted balconies; they will contain hotel and condo-hotel units managed by Grand Hyatt. A glass-clad low-rise structure will contain 265,000 square feet of shops and restaurants

topped by a five-acre sandy beach and pool. The 6.9-million-square-foot project is packed into a narrow 8.5-acre site.

"Las Vegas projects, in the past, have been set back from the street with huge porte-cochere entrances. The Cosmopolitan, however, is a truly urban project that reaches toward the sidewalk and engages the energy of the Strip," says Bernardo Fort-Brescia, FAIA, a principal of Arquitectonica. He adds that its design is a "purely abstract architectural expression."

Arquitectonica is working on



The Las Palmas towers' gold bands.

another hotel/condo complex called Las Palmas, located on Paradise Road just east of the Strip. The \$1.6 billion, 4.5-million-square-foot project will consist of four, 55-story

aqua-colored glass towers—each accented by golden ellipses—containing 1,800 hotel and condo units.

Both developments, due to open in 2009 and 2010, respectively, give Arquitectonica a second chance in Las Vegas after two previously planned developments folded. The Related Companies had tapped the firm to design its Las Ramblas and Icon Las Vegas condominium projects in 2005, but both jobs were later canceled amid rising construction costs and fears of an overheated condo market. Ironically, real estate experts say that those projects' cancellation allowed Arquitectonica's new jobs to move forward. *Tony Illia*





DUAL-STACKED BURNERS FROM WOLF.  
YOU'RE IN COMPLETE CONTROL.

*With Wolf you can.* With two independent burners that provide settings from 300 to 15,000 Btu<sub>s</sub>, cooks can easily handle any cooking task from melting to searing. The only thing they may find difficult is choosing from the wide range of Wolf models this exclusive feature is now available on. Learn more at [wolfcookingtrade.com](http://wolfcookingtrade.com) or call 800-332-9513.



CIRCLE 20 ON READER SERVICE CARD OR GO TO [ARCHRECORD.CONSTRUCTION.COM/PRODUCTS/](http://ARCHRECORD.CONSTRUCTION.COM/PRODUCTS/)



## Oscar Niemeyer to celebrate 100th birthday

Oscar Niemeyer, one of the 20th century's greatest and most imaginative Modernist architects, is due to mark his 100th birthday on December 15. But why limit his biography to just one century? The centenarian maintains an active practice in his hometown of Rio de Janeiro, Brazil.

In contemplating Niemeyer's career, which began during the 1930s when he joined a team of Brazilian architects collaborating with Le Corbusier, a good case can be made that his legacy will be Brazil's capital, Brasília. He was engaged to advise on the city's design in 1956 and soon became its chief architect, creating many of the key public buildings until changing political winds forced him to leave the country in 1964.

Contemporary observers might fault this city *ex novo* for its decid-



edly unsustainable qualities, as indeed past generations saw it as overblown and bleakly underpopulated, but it's hard to ignore the influence that Niemeyer's dynamic, sculptural forms—rendered largely in concrete—still have a half-century later. *James Murdock*



Designed and built during the late 1950s and early 1960s, Oscar Niemeyer's buildings in Brasília (top left) include the Planalto Palace (top right), Brazil's National Museum (above right), and the Cathedral of Brasília (above left).

## Sleuthing forgotten women's contributions

If you didn't know better, you might think that the history of women practicing architecture and design began with women's lib during the 1960s. Earlier figures, including Lilly Reich or Catherine Bauer, are virtually unknown despite their central role in high-profile projects: Reich codesigned the famous Barcelona chair, usually attributed solely to Mies van der Rohe, and Bauer was an early hero of social housing who coauthored the Housing Act of 1937, establishing public housing in the U.S.

Who better to help uncover these forgotten stories than Gwendolyn Wright, a host of the popular PBS series *History Detectives* and professor of architecture at Columbia University's Graduate School of Architecture, Planning, and Preservation. She was the keynote speaker on October 25 at a symposium titled *Women in Modernism: Making Places in Architecture*. The event was sponsored by the Museum of Modern Art (MoMA) in

Manhattan and the Beverly Willis Architecture Foundation, with the goal of recontextualizing the role that women played in Modernism.

Wright outlined certain myths that have perpetuated incomplete versions of history, offering as an example the idea that many 20th-century arbiters overvalued an ideal type of architect who was hyper-rational, uncompromisingly idealistic, and invariably male. Important figures falling outside that standard were either unnoticed or, if they did achieve recognition, soon forgotten. For example, even with today's booming interest in sustainability, it's a rather obscure fact that architect Eleanor Raymond, who worked in Boston for more than 50 years, and chemist Dr. Maria Telkes, from MIT, built what was arguably the first solar-powered house, the Dover Sun House, in 1948. Another overlooked figure is Elizabeth Mock, a MoMA architecture curator during the 1940s whose *Built in USA: 1932–1944*

show presented an alternate history of architecture that affirmed a diverse and regional Modern style. Wright challenged the audience to resist “myths that are clearer and more convenient than real history.”

In a panel discussion after Wright's talk, moderated by MoMA's chief architecture curator Barry Bergdoll, speakers shared similar examples of neglected contributions made by women in architecture. Sarah Herda, executive director of the Graham Foundation for Advanced Studies in the Fine Arts in Chicago, said that her colleagues relentlessly insisted that her appointment as director was revolutionary. But after digging through the Graham's archives, she found that women had operated at the institution's highest levels since its founding in 1956. Catherine Bauer, for instance, was a consultant who urged the establishment of a foundation upon Ernst Graham's bequest—but until Herda's archive project that knowledge had been forgotten.

While panelists offered plenty of

examples showing how women's contributions are deliberately or unwittingly forgotten, they were short on explanations for why it happens. Karen Stein, a former editorial director of Phaidon Press and a former senior editor of RECORD, evoked chaos theory's famous question—does the flap of a butterfly's wings in Brazil set off a tornado in Texas?—to explain how internal and enigmatic mechanisms of power in any field can magnify small, unintentional acts into widespread problems. But she also said that the butterfly effect provides a reason to look forward with optimism, because “any statement made tonight has the potential to change the course of architectural history.”

Toshiko Mori, FAIA, who chairs the Department of Architecture at the Harvard University Graduate School of Design, shared a desire to think optimistically about the future. Proclaiming herself a woman of action, she said, “The time is for us to make the history. We can't stay where we are. We can't keep looking back.” *Henry Ng*



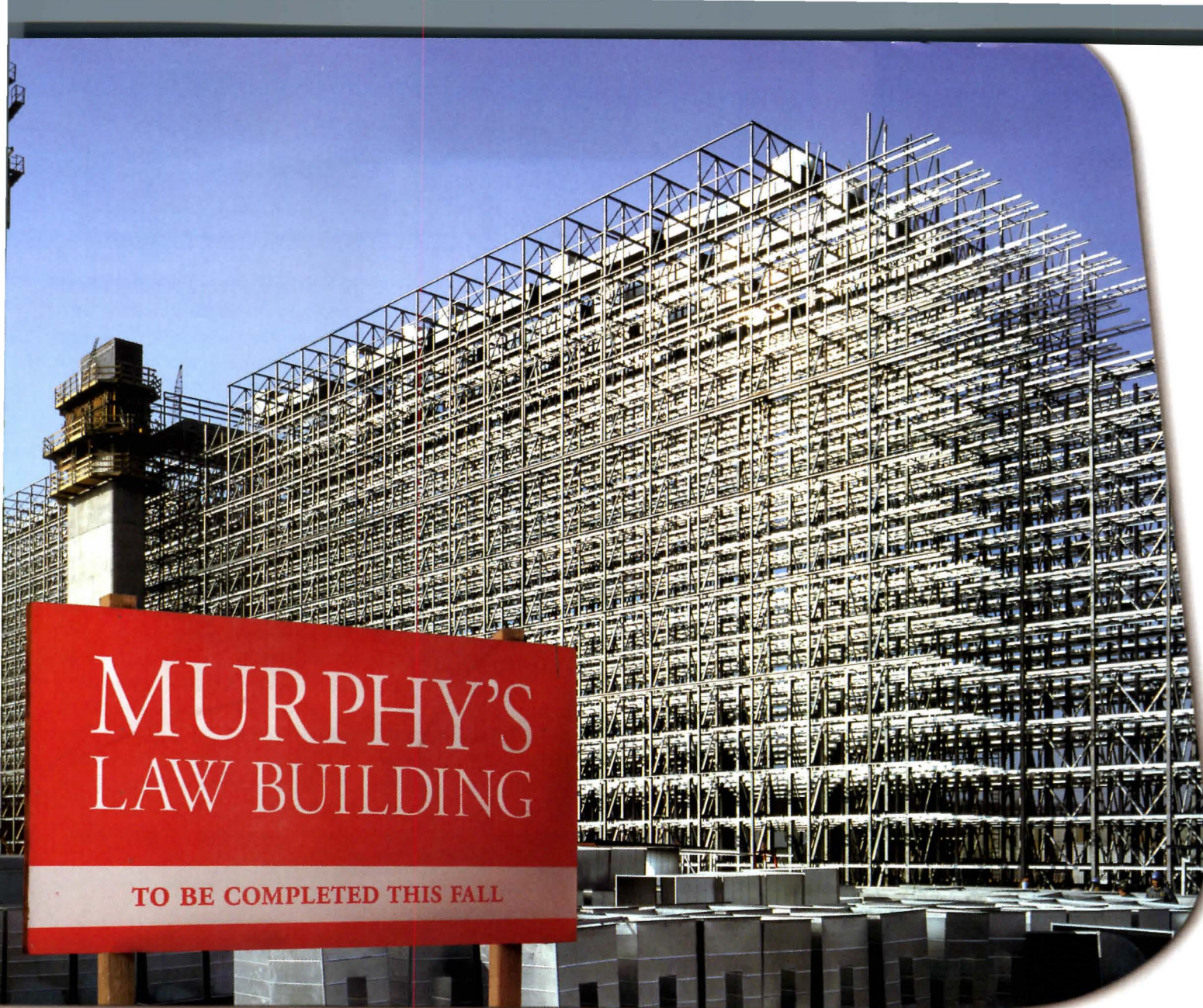

# MURPHY'S LAW BUILDING

TO BE COMPLETED THIS FALL

No worries. We've got your back.  
(And all the other sides as well.)

.....

When it comes to architecture, creativity in general is risky. But some projects are more prone to risk than others. Travelers understands this, and offers a wide range of insurance and risk management solutions. For more information on Travelers insurance for architects, contact your independent agent or call 877.237.6588, ext. 32253. Because whatever can go wrong doesn't have to. And certainly doesn't have to affect you.

travelers.com

**TRAVELERS**   
Insurance. In-synch.<sup>SM</sup>

©2007 The Travelers Companies, Inc. All rights reserved. The Travelers Indemnity Company and its property casualty affiliates. One Tower Square, Hartford, CT 06183

CIRCLE 21 ON READER SERVICE CARD OR GO TO [ARCHRECORD.CONSTRUCTION.COM/PRODUCTS/](http://ARCHRECORD.CONSTRUCTION.COM/PRODUCTS/)





The Door With A Split Personality



Automatic Operation  
When You Need It,  
-and-  
Balanced Door Operation  
When You Don't.

Balanced doors will never be the same thanks to this completely unobtrusive, ingenious, automatic door operator. It's perfect for ADA applications and excellent for smoke evacuation. And, like all Ellison products, it's built to last.

ellison

BALANCED DOORS  
& CUSTOM ENTRANCE SOLUTIONS  
www.ellisonbronze.com

800.665.6445

CIRCLE 22 ON READER SERVICE CARD OR GO  
TO ARCHRECORD.CONSTRUCTION.COM/PRODUCTS/

## Record News [architecturalrecord.com/news/](http://architecturalrecord.com/news/)

### Construction volume could continue decline in 2008

An overall decline in construction starts in the United States could prove more dire than originally thought. McGraw-Hill Construction, RECORD's corporate parent, estimates that the industry saw an 8 percent drop in construction starts in 2007, and it forecasts another 2 percent slide in 2008. This prognosis was released in October during McGraw-Hill Construction's 2008 Construction Outlook conference, in Washington, D.C.

After reaching a record \$668.9 billion in total construction starts in 2006, values are expected to hit \$626.7 billion for 2007 and \$614.1 billion in 2008. Last year, McGraw-Hill Construction predicted that starts in 2007 would drop 1 percent as the single-family-housing market weakened and other sectors, such as institutional work, remained strong.

Robert A. Murray, vice president of economic affairs at McGraw-Hill Construction, said the turmoil in the subprime mortgage market that emerged this summer has created a major concern for the construction industry and the overall economy. He added that tightening lending conditions will impact development in both residential and commercial real estate: "As a result, we're now predicting downturns in the

previously resilient multifamily and commercial segments, as well as continued weakness in single-family-home construction."

Single-family residential construction remains the main drag on overall construction starts, with a 25 percent plunge estimated in 2007. Declines will continue in 2008 but could ease considerably with dollar volume expected to fall only an additional 3 percent, according to McGraw-Hill's numbers. Multifamily housing is also expected to slide 8 percent in 2008, to \$56.4 billion, after a nearly 12 percent drop in 2007. Faced with tighter lending standards, commercial buildings will take a hit as well, projected to drop 6 percent in 2008.

Some trends are more positive, particularly in the public sector, as many state and local governments remain fiscally strong, Murray said. Public works could realize a 3 percent gain, to \$120.95 billion, in 2008. Values of institutional building could rise 4 percent, to \$118.7 billion, next year, while the square footage of those projects will remain essentially flat, experiencing a modest 1 percent increase. School construction will be a strong contributor to growth in the sector, rising 7 percent, to \$56.3 billion next year, while health-care starts will flatten, with a 1 percent drop predicted. *Bruce Buckley*  
A version of this story first appeared in McGraw-Hill Construction's Engineering News-Record.

### AIA's billing index slips again

Worries over how long the credit crunch will continue to impact residential construction are having a spillover effect on lending in commercial markets. The Architectural Billings Index (ABI), prepared by the American Institute of Architects (AIA), reflected these jitters in September, falling 2.8 points, for a score of 51.1. It was the index's second down month in a row, although any value over 50 indicates growth.

How long will credit uncertainty continue? "My own sense is that we haven't seen the end of it yet," says Kermit Baker, the AIA's chief economist. "This quarter and the next one are going to be peak quarters for where subprime mortgages reset. Can those borrowers afford their payments, and will we see default rates picking up? The story is still unfolding."

Even if the residential sector remains battered next year, there are some bright spots for architects. The number of remodeling projects will likely increase as people decide to stay put rather than build new houses, Baker says, and as a rule,

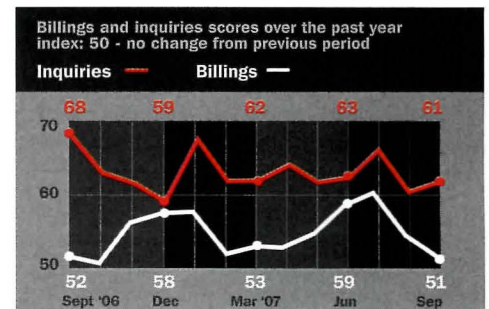

the larger the job, the more likely an architect's services will be needed.

When it comes to commercial construction, meanwhile, architects tend to be canaries in a coal mine. "If there's a problem in financing a development, it often happens simultaneously to design, and so generally one of the first phone calls an owner makes is to the design team to stop work," Baker says. The same goes for when financing uncertainty is resolved: Architects hear first. So what sort of noises are the canaries making now? The number of inquiries for new projects in September rose slightly, for a score of 61.4. *James Murdock*





Breuer in a Wassily.

**Marcel Breuer, eulogized as the last Modernist** upon his death in 1981, is in the headlines today as his buildings meet with uncertain fates. A retrospective at the National Building Museum in Washington, D.C., aims to remind people of the contribution

that he and other Modernists made through their bold experimentation with forms and materials. *Marcel Breuer: Design and Architecture*, through February 17, traces his creative evolution from a furniture designer to architect. It includes his iconic Wassily chair and 12 building models. *Violet Law*

**The Smithsonian Institution awarded** a programming contract for the National Museum of African American History and Culture, touted as the final museum on the National Mall, to Davis Brody Bond and The Freelon Group. "This can be more than a building," says Philip G. Freelon, FAIA, principal of The Freelon Group. "It can be a catalyst for the country to address the issue of race in a positive and constructive way." The \$4 million study will run 18 months, and the museum is slated to open in 2015. The Smithsonian has also issued an RFQ, due January 7, for an unprecedented public-private redevelopment of its Arts & Industries Building, designed by Adolf Cluss and originally opened in 1876 for the Centennial Exhibition. Safety concerns and funding deficits forced its closure in 2004. A museum spokesperson says that it will cost an estimated \$55 million to \$65 million to update the 180,000-square-foot building's shell to satisfy current code requirements. *Barbara J. Saffir*

**Michael Graves's long-awaited Detroit Institute of Arts redesign opened** on November 23. The museum hired Graves in 1989 but soon afterward shelved the project after losing government funding. Although the \$158 million project adds just 10 percent more space to the existing 600,000-square-foot complex, it reorganizes circulation and galleries, which grew haphazardly since the original Paul Cret-designed



Marble in the same vein?

museum opened in 1927. Observers have responded favorably to the renovation, but some criticize the decision to use marble from the original quarry to re clad two wings. The older marble experienced accelerated aging, due to a poor cleaning job, and the new pieces might never match its look. *John Gallagher*

**The New Museum opens** its new home, by Tokyo-based Sejima + Nishizawa/Sanaa, on December 1. When New York City's only all-contemporary-art institution unveiled the design in 2003, observers expected that its off-kilter stack of six white boxes would act like too much of a show off on a formerly grungy Lower East Side block. But it turns out that the neighborly 60,000-square-foot building engages passersby and visitors alike—



New Museum, new 'hood.

particularly on its ground floor, where a glass-walled facade allows views through the lobby and into galleries and loading docks beyond. Video installations on this level will probably run all night, says coproject architect Toshi Oki, so that "at 3 o'clock in the morning, you will see the art from the street." *Alec Appelbaum*

**Massachusetts College of Art and Design will admit** its first cohort of 10 students for a master of architecture program in the summer of 2008. The Massachusetts Board of Higher Education unanimously approved the school's application to offer this new graduate degree in October. The curriculum will emphasize both hands-on construction, through design-build studio courses, and social awareness, fostered by encouraging students to satisfy the needs of nonprofit community groups. *James Murdock*

#### ENDNOTES

- Carnegie Mellon University architecture professor Volker Hartkopf was named chair of the United Nations Environment Programme Sustainable Building Construction Initiative.
- Anshen+Allen, based in San Francisco, is opening an office in Columbus, Ohio, to be headed by newly hired principals Gregory Mare, AIA, and Thomas Snearey, AIA.
- X-Rite has purchased the color standards company Pantone for \$180 million.

A FULL LINE OF COLORS  
BUT EVERY DOOR IS GREEN.



Call or visit us online for information on our environmentally friendly doors and the VT CORE Distributor program.

**Architectural Wood Doors**  
INDUSTRIES

WWW.VTINDUSTRIES.COM  
800.827.1615 ext. 345

CIRCLE 24 ON READER SERVICE CARD OR GO TO [ARCHRECORD.CONSTRUCTION.COM/PRODUCTS/](http://ARCHRECORD.CONSTRUCTION.COM/PRODUCTS/)





new **edges.**  
new **finishes.**



**Indiana Limestone Vanderbilt Classic.™**

Presenting exciting new designer edge treatments and finishes for Vanderbilt Classic—an innovative, precision cut, genuine Indiana Limestone building veneer. Its modularity offers you the look of custom cut stone at a surprisingly lower cost. Discover Limestone Classics® at [IndianaLimestoneCompany.com](http://IndianaLimestoneCompany.com) or call (800) 457-4026.



Smooth  
Abrasive  
Bush-Hammered  
Straight Edge  
Reveal Edge  
Chamfered Edge Two Sides  
Chamfered Edge Four Sides

INNOVATIONS  
IN  
STONE

CIRCLE 25 ON READER SERVICE CARD OR GO TO [ARCHRECORD.CONSTRUCTION.COM/PRODUCTS/](http://ARCHRECORD.CONSTRUCTION.COM/PRODUCTS/)



# For and about the emerging architect

## archrecord2

DEPARTMENTS

**Architects as developers: Not a new concept, but when the people in question are young sole practitioners who don't have the cash in hand to realize their visions, the challenges are unique. archrecord2 found two ambitious designers in unlikely places, Chris Krager of KRDB in Austin, Texas, and Tom Allisma of Tom Allisma Productions in Omaha, Nebraska. ONLINE: Should architects seek to be developers or just stick to designing? Respond at [construction.com/community/forums.aspx](http://construction.com/community/forums.aspx).**

### Design

#### KRDB: The art of the deal



How does a guy with a degree in finance from Michigan State University end up as principal of an architecture firm in Austin, Texas?

"Currency arbitrage just wasn't giving me a creative outlet," laughs Chris Krager, principal of Austin-based KRDB. "I did the banking thing for four years. That was enough." Krager moved to Austin to seek a degree in architecture. "I wanted to build, and the University of Texas had a good balance of theory and practice."

Krager worked for several esteemed architects including Michael Rotundi, Kevin Alter, and Juan Miro, before he and his friend Chris Robertson started KRDB (Krager Robertson Design Build) in 2000. While the firm's main mission was to offer modern design at an affordable price, Krager had other aspirations for the practice. "I always saw the vertically integrated package as the way to go," he says, "where we act as developer, designer, and builder. I thought, the city must have a program or incentives for this kind of work in the kind of neighborhoods we were interested in. They did, and though we had no track record, we borrowed the money and made it happen." The firm's first few projects, including Cedar Avenue, two residences on Austin's East Side, garnered interest from both the local and national press, and more clients came. Still, Krager wasn't seeking commissions as much as he was interested in the development side of the business. In 2004, when Robertson left the firm to pursue his own projects, Krager was able to redirect the practice.

"Maybe it's my banking background," he says, "but I love the deal. I love gathering the players—the investors, the contractors, the neighborhood organizations—I love partnering with all these different groups, then creating the right design and developing the project. I love finding the city incentives and keeping the costs down while keeping the design above a certain standard. It's challenging, but



#### South First, Austin, Texas, 2008

*On a long, narrow lot, this 16,000-square-foot mixed-use project became an exercise in creating an interior streetscape, with courtyards and balconies.*



#### Bergen County Development, New Jersey, 2010

*A 10-acre, mixed-use, mid-rise multifamily development in partnership with Allee Design is on the site of an existing commercial warehouse.*

IMAGES: COURTESY KRDB





**KRDB Modular, U.S., unbuilt**

KRDB's modular line, in two module sizes, 36-by-15 feet or 60-by-15 feet, has three floor plans available, which make up the six building blocks of the system.

very rewarding." Krager says that finding investors hasn't been that difficult, either. "One person bought a spec house I developed, and now he's a partner in my modular company," he says. "People like him aren't the type who are just looking at the bottom line. They're interested in design, in sustainability, and they're interested, as I am, in economies of scale."

KRDB has a slew of development projects in the works, including multi-family housing in Austin and mixed-use projects in New York and New Jersey. With Krager heading up all segments of the practice, the daily business of running a growing firm can be challenging. "I guess I'm just one of those people who functions more efficiently when I have more to get done," he says. "If I stopped and thought about what's happening, I'd have a heart attack. I enjoy the broad scope of what I'm doing, and I'm a little ADD—I have a short attention span, so it works." *Ingrid Spencer*

For more photos and projects by KRDB, visit [architecturalrecord.com/archrecord2/](http://architecturalrecord.com/archrecord2/).

## Design

### Tom Allisma: Developing a taste



Omaha is better known as the heart of corn country than as a hotbed of architectural design, but it has proved fertile ground for one young designer. Tom Allisma, Assoc. AIA, balances teaching interior design; acting as principal of his design firm, Tom Allisma Productions; developing concepts; and designing restaurants and bars, which he and his business partners also finance.

Allisma wanted to be a designer and never expected to become involved in development, much less the restaurant business. However, soon after beginning his career with a local architecture firm, he became good friends with Nick Hogan, a developer and attorney. Hogan asked Allisma to design an office space for his real estate development company, which earned an awards citation at the 2002 Central State AIA Awards.



**Roja Mexican Grill, Omaha, Nebraska, 2004**

*Metal, concrete, copper, stone, and wood give a modern feel to old-town Mexican.*

Following the success of that collaboration, Hogan made Allisma another offer: an opportunity to partner in the development of a sushi restaurant. Allisma had never tried the cuisine but thought the idea of "raw fish in the heart of corn country" was intriguing. After a trip to the West Coast and his first taste of sushi (he liked it), he designed a restaurant based on "coastal abstractions." BLUE Sushi Sake Grill includes water features and a 30-foot-long, blue-laminate, backlit canopy over the dining room. Birch plywood, canvas, and copper round out the soothing material palette, balanced by stained concrete floors and bar counters.

BLUE quickly became a local sensation. Encouraged by its success, Allisma and Hogan continued to develop restaurant concepts, investing equal finances up front and sharing ownership with the remaining percentage sold to the chef or restaurant manager. In late 2004, they unveiled Roja Mexican Grill, followed by Bianco Ristorante Italiano. Both spaces were again inspired by Allisma's travels. Roja's "industrial Mexican" aesthetic—incorporating corrugated metal, concrete, copper, cultured stone, and raw wood—is his modern interpretation of Spanish Colonial architecture. Bianco, influenced by northern Italy, features an orange-and-white acrylic lantern that acts as divider/seating between bar and restaurant.



**Bianco Ristorante Italiano, Omaha, Nebraska, 2006**

*An orange-and-white lantern acts as a centerpiece, seating, and a divider between bar and restaurant. An original 1966 Vespa and old Italian movies projected on the wall add to the ambience.*



**Blue, Omaha, Nebraska, 2002**

*With an 8-foot-wide waterfall, 500-gallon fish tank, and 30-foot-long backlit canopy over the dining room, Blue is not your typical Midwestern eatery.*

Parallel to the success of his restaurant ventures, Allisma fulfilled his dream of establishing Tom Allisma Productions. More than half of his clients are customers from his restaurants and bars who admired the design and commissioned him to do their homes or businesses. "A whole new world of opportunities opened up to me ... a client list that I would have never been able to establish without the exposure of all my business ventures."

Allisma and Hogan have several restaurant and bar projects set to open at the beginning of 2008 and are constantly coming up with new ideas. The collaboration, Allisma says, has been "amazing. We complement each other. Nick has a legal/finance background and [my] design/marketing background really helps out as we develop new concepts." *Murrye Bernard*

For additional photos and projects by Tom Allisma Productions, go to [architecturalrecord.com/archrecord2/](http://architecturalrecord.com/archrecord2/).



## Exhibitions

By Russell Fortmeyer

### Keith Edmier 1991–2007.

Curated by Tom Eccles. At the Bard College Center for Curatorial Studies, Annandale-on-Hudson, New York, through February 3, 2008. [www.bard.edu/ccs](http://www.bard.edu/ccs).

As the subprime mortgage market implodes and banks foreclose on houses nationwide, Bard College is putting American domesticity on the front lines in New York artist Keith Edmier's midcareer survey, *Keith Edmier 1991–2007*, at the Center for Curatorial Studies. Bard especially commissioned Edmier to recreate the interior of his 1971 childhood home, in all its wallpapered, plastic-fantastic, tract-house splendor, as the centerpiece of the exhibition's galleries.

The specifics of Edmier's home—called *Bremen Towne*—are as banal as anything suburban America has ever imagined. Consider it, if you will, as a new listing: a three-bedroom ranch house; 1.5 baths; eat-in kitchen; professionally decorated, attached two-car garage; and an optional, bonus family room. It's meant to be located in the real BremenTowne Estates—a new “total-living” community—in Tinley Park, Illinois, a tony suburb of Chicago. Edmier recreated everything except the exterior, garage, bedrooms, and bathrooms in Bard's galleries. Inside the house, the installation reads as a single structure. In the kitchen, you can easily forget you're in a museum.

Starting from scratch, Edmier reconstructed the finishes of his house based on personal photo-

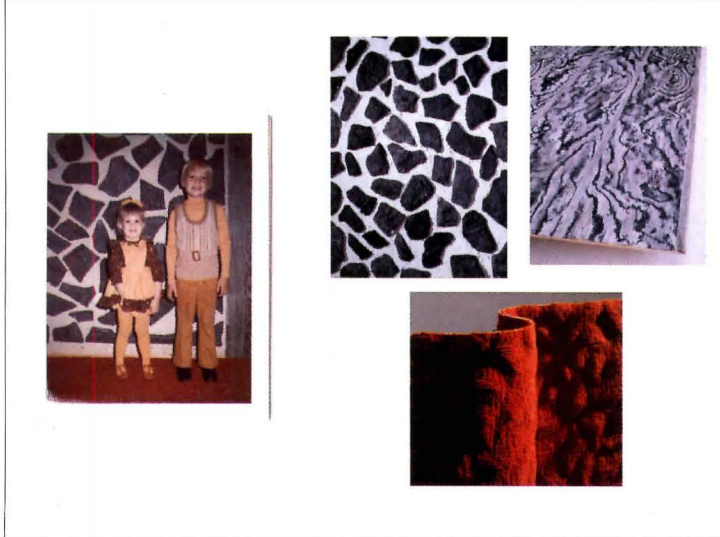

**An installation view of the family room of Keith Edmier's *Bremen Towne* (2007) at Bard College (top), with the architectural plans (top right). Edmier compiled source material from family photographs (above).**

graphs—the kitchen's harvest-gold appliances and countertop, matched with a faux-pebble vinyl tile, were found in birthday and family-pet photographs from the 1970s. This source material is cleverly documented, with essays and an

interview by Edmier's friend, the artist Matthew Barney, in an odd but fascinating, quasi-biographical book accompanying the exhibition.

Edmier is not known for working in the medium of architecture. His other work consists of cast

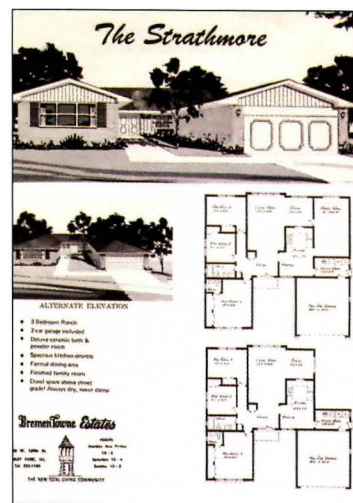

sculptures in various mixtures of urethane, silicone, resin, and dental acrylic, of celebrities from his childhood—Farrah Fawcett, Evel Knievel, and John Lennon. But the artist says he wanted to explore the physical context of his youth as the site from which his interests as an artist conceivably emerged. At one point, he considered buying his old house, returning it to its “brand-new” condition, and opening it as an arts center. Bard even considered buying a house near its campus to do the same thing, but eventually settled on what we see in the galleries.

To walk through the house, then, is to understand a key part of the artist's biography as much as it may also be plain-old voyeurism. Edmier initially planned to install his art inside the house, but felt the house could act as a buffer from the outside world or as a shield from the *other*, to use contemporary art history's parlance, which is represented by the exhibition of the bulk



## Exhibitions

of his work. This reminds us that we—including architects—don't always want to think of our house as architecture, but as a safe, secure home. But *Bremen Towne* is also an art project, which acts as a critical extension of the tangible world—in this case, Edmier's tangible world.

The artist said in an interview that he had some trepidation about re-creating spaces that were so loaded with memories—and don't we all? The architectural theorist Anthony Vidler has written extensively on the uncanny in architecture and literature, often focusing on its "negative" aspects—its tendency for exposing a denial or repression, only to render it inaccessible. In a 1990 essay, "Theorizing the Unhomely," he writes that the home "pretends to afford the utmost security while opening itself to the secret intrusion of terror." In an age when typing in



**Edmier reconstructed his kitchen from photographs, using new and old materials. The wallpaper, shown in this installation view, was made from scratch.**

an address on the Web site Zillow returns the value of nearly any home in America, and glass condominiums increasingly expose domestic life to strangers, perhaps it's clear we've finally buried America's long-held clichés of "home."

Strangely, for as much as Americans obsess over decorating and real estate, our contemporary understanding of house and home

are not things we regularly see so explicitly criticized in a museum context. Traditional institutions, such as New York's Metropolitan Museum, have always maintained period rooms that mostly display the fittings and furnishings of luxurious residential interiors. Even the Getty Center in Los Angeles installed a series of European interiors when it opened in 1997. In some ways,

Edmier continues that tradition.

But he's also working in a context of architectural research that has straddled the line between the production of art and architecture since at least the 1960s. Chief among those artists, the late Gordon Matta-Clark sliced raw cuts through abandoned houses and other structures in the 1970s in order to render their economic value and social symbolism useless, exposing the logic of architecture as a real construction. More recently, the Los Angeles artist Jorge Pardo built his own house as a private art project paid for, in part, by a public museum. But these projects aren't charged with the biographical details of the artist's life—they invent a new life. Edmier, however, is returning to old ground by constructing a rich, textural landscape of pop surfaces. It's not the categories of art and architecture that are under ironic attack here, it's domestic life in all its post-boomer weirdness. And we're all invited to this open house. ■

## Not your garden variety green roof



A "successful" green roof is one that stays watertight and looks great over time - not for just the first or second year, but for decades. American Hydrotech's Garden Roof® Assembly is based on more than 35 years of proven green roof technology and experience. Because it's designed from the substrate up as a "complete assembly", it's much more than just the sum of its parts.



Ballard Library - Seattle, WA (2006 Green Roof Awards of Excellence winner)

American Hydrotech's Total System Warranty provides owners with single source responsibility from the deck up. This is a warranty that only American Hydrotech can offer, and peace of mind that only American Hydrotech can provide.



Long recognized as an industry leader, American Hydrotech continues to offer new products that allow us to better meet your needs. To learn more about what American Hydrotech can do for you, please give us a call at **800.877.6125** or visit [www.hydrotechusa.com](http://www.hydrotechusa.com) for more information.

303 East Ohio Street

Chicago, IL 60611

800.877.6125

[www.hydrotechusa.com](http://www.hydrotechusa.com)

CIRCLE 28 ON READER SERVICE CARD OR GO TO [ARCHRECORD.CONSTRUCTION.COM/PRODUCTS/](http://ARCHRECORD.CONSTRUCTION.COM/PRODUCTS/)



# Legal loophole trumps good zoning in SoHo

## Critique

By Michael Sorkin

The form of the city rises from the convergence of legislation, imagination, ambition, and resistance. This complex of forces is getting a workout a few blocks from my office in Lower Manhattan, where Donald Trump and partners are building the Trump SoHo, a 45-story “condominium hotel” containing 400 apartments—ranging in size from 425 to 10,000 square feet—priced at \$3,000 a square foot and said to be selling briskly. The tower, which is going up fast and is scheduled to open in spring 2009, sits adjacent to SoHo and will be, by far, the tallest building in an area characterized by structures of six to 15 stories. Like most Trump projects, the architecture, by Handel Architects, is merely bland, another glass box. Because of its size, however, it whimsically rescales the entire neighborhood, permanently marring the low roofscape that stretches downtown and culminates in the Lower Manhattan skyline. It’s a view I take in every morning as I walk to work, and the new tower already constitutes an awful scar on the sky. As urbanism, it’s vandalism.

The controversy that surrounds the building, however, focuses on questions that exceed size. Use is the real issue: The hotel-condominium bifurcation is Trump’s strategy for building a residential structure in a neighborhood zoned for manufacturing, the last such district in Lower

*Contributing editor Michael Sorkin runs Michael Sorkin Studio and is the director of the urban design program at City College of New York.*



The 45-story Trump SoHo towers above all of its neighbors.

Manhattan. Although this zoning category does not permit residential structures, it does allow conventional hotels, which the code describes as facilities where units “are rented on a daily basis” and used “primarily for transient occupancy.” The condo hotel is a relatively new real estate product, introduced to New York in recent years and, to date, only in areas with residential zoning. It’s clear, though, that the zoning code was written well before any of its framers could possibly have imagined this particular bending of the idea of a “transient hotel.”

Because of this lack of specificity and obvious precedent, Trump has needed to finesse the nature of the project’s occupancy, to create a

standard of transience. According to the deal struck between him and the city (via a “restrictive declaration” now described as “voluntary”), although the tower is clearly an apartment building—that is, a building filled with units that in every way resemble apartments, with kitchens, baths, bedrooms, and the rest—individual owners will be permitted to occupy their apartments a maximum of 120 days a year and no more than 29 out of any consecutive 36 days. There appears, however, to be no obligation to rent when vacant, although there will certainly be strong financial inducements to do so.

Despite gales of criticism from activist groups (who recently staged a demonstration at the construction

site) and the discovery during excavation of a cemetery from a pioneering abolitionist church that once occupied the site, the project has moved ahead at breakneck speed. Recently, if tardily, a consortium of community organizations has announced a lawsuit against the city for permitting the project. The city has promised to defend it, arousing further outcry about the use of taxpayer money to pull Trump’s chestnuts out of the legal fire.

The suit’s claim will undoubtedly focus both on the appropriateness of the building—which will be a tough battle against arguments that it is, thanks to the loophole, technically “as of right”—and, perhaps more promisingly, on Trump’s claim that it is actually going to be a hotel. Here



## Critique

the issue devolves on whether what walks, flies, and quacks like a (residential) duck is actually another species. Trump has advertised the units as “residences” (there has been much back-and-forthing about advertising that crosses this line), and the legal confrontation will surely fix on the semantic technicalities of the meaning of “transience.” To be sure, the jet-set masters of the universe who buy into the property are an extremely transient class, but this certainly can’t have been what the framers of the code had in mind when they distinguished “residential” hotels (not permitted) from “transient” ones (allowed).

One obvious question is why Trump and his partners aren’t simply building an actual hotel on the site. According to Julius Schwarz, executive vice president of the Bayrock Group (which initially secured the site with the Sapir Organization before bringing in Trump for his inimitable cachet) and the managing partner for the project, “It’s a financing mechanism” designed as a hedge against a potential glut of hotels. “You can model it out 10 years. Right now, there’s a shortage of hotels. So people are going to be building hotels and the rates will eventually come down. Hotel rooms will always be in high demand, but you can’t rely on the \$1,200-a-night rates. Even with a very high-end luxury hotel like this, you have to convince a lender. That’s the most important thing; otherwise the deal doesn’t get done.”

What this is likely to mean is that the lawsuit will focus on Trump’s intentions and on the enforceability of his “voluntary” agreement to limit the days his high-rollers are actually in the building. Will he really send the concierge to remove the owner of a \$10 million unit about to stay for a 30th straight day? It likewise seems highly unlikely that the New York City Building Department, which is responsible for enforcement, will have either the resources

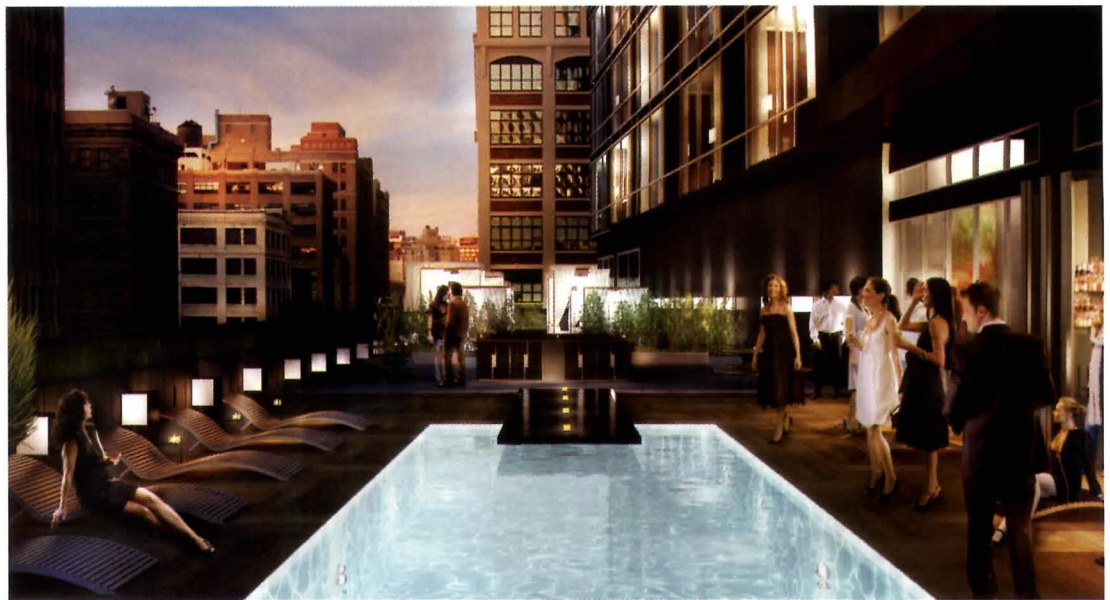

**Trump SoHo is targeting people who can buy multimillion-dollar apartments that they will occupy only intermittently.**

or the inclination to monitor 400 apartments on a daily basis to see exactly who’s behind the closed doors. The scope for scams and greased palms is virtually limitless, and the only real question is whether the city actually believes in the enforceability of the arrangement or is simply acquiescing in a situation it knows to be absurd.

### A Trojan horse

The fate of the lawsuit is not clear and seems a long shot for this particular project. Part of the intent of litigating, however, is to force the city to close the loophole in the zoning code that has permitted the tower. The lawsuit also seeks to head off similar “Trojan horse” projects that might rise in other manufacturing zones around Manhattan, including chunks of Chelsea, Greenwich Village, Tribeca, SoHo, and the Garment District, among others. Unfortunately, the planning department has not indicated that it sees any urgency in revising the code. Big buildings for big money are at the top of the municipal development agenda, and the site, although it is in an industrial district, adjoins some of the most expensive residential areas in the city.

However, the building’s real affront is broader than the fact that another developer has found

another way of manipulating the zoning laws to his advantage, and it has to do with both the city’s mix of uses and its mix of people. Certainly, the outcry would have been much less had the site, which was vacant, been developed with a 12-story building for moderate-income families or an art center. And, although many of us idealize a certain vision of urban vitality—one that still includes manufacturing and other industrial uses—the inhospitality of both the national economy and the local real estate market to such activities is powerful. But the category of manufacture also encodes the idea of a working class, and the widespread resistance to the city’s tide of luxurious residences and Class-A offices reflects alarm at the increasingly monochrome, if glossy, character of the city.

Like the nation, New York lacks an adequate industrial policy, and Trump SoHo, like the neighborhood next to it, represents the transformation of an “obsolete” industrial district into something more congenial to the current market. This transformation reproduces at the scale of the city, something that is going on globally, a kind of spatial segregation—or zoning—of continental reach: New York’s industrial neighborhoods are now in China or Mexico. What is sacrificed locally, though, is not simply blue-collar

employment, but a vital idea of what constitutes a city, an idea that includes notions of self-sufficiency and diversity. One of the things that can make a city great is the spectacle of equity, a sense of the “right to the city” that combines access to both its places and possibilities. We rely on public space and public policy to lay out a framework for this freedom.

The motto emblazoning the construction marquee surrounding the new project is succinct: “Possess Your Own SoHo.” In the vulgarity of their sumptuary obsessions, Trump and his hotel are fine symbols of an urbanism of pure extraction that has little interest beyond the bottom line. The city becomes the territory of acquisitiveness, of the sort of civic disengagement suggested by the lifestyles of those who can afford to own multimillion-dollar apartments they will occupy only a month at a stretch. For them, possession displaces participation as the reason to be in the city, and their privilege is a growing affront. They come to spend, and it’s no wonder that municipal authorities so often find the froth of growth irresistible for their own bottom line. ■

**ONLINE:** Will the Trump SoHo really ruin the area? Respond at [architecturalrecord.com/community/critique](http://architecturalrecord.com/community/critique).



# Exploring the work of architects starting to hit their stride

## Books

**David Adjaye Houses: Recycling, Reconfiguring, Rebuilding**, edited by Peter Allison. New York: Thames & Hudson, 2006, 256 pages, \$35.

**David Adjaye: Making Public Buildings**, edited by Peter Allison. London: Thames & Hudson, 2006, 224 pages, \$28.

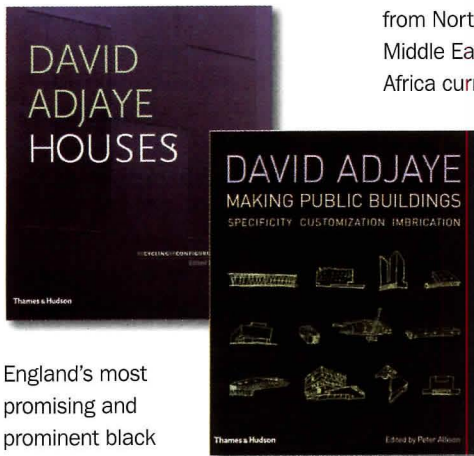

England's most promising and prominent black architect, David Adjaye [RECORD, Design Vanguard, December 2002, page 126], was born into a Ghanaian diplomatic family in Tanzania 41 years ago and lived in the Middle East and Africa before moving to London in 1979. Adjaye attended the Royal College of Arts, rather than architecture school, and takes pleasure in collaborating with artists and designing spaces for them to work and live in. As Deyan Sudjic writes in *David Adjaye Houses*, Adjaye "is as close to his contemporaries in the art world as any architect of his generation." His best known projects include a series of colorful libraries, called Idea Stores, in low-income neighborhoods in London;

a brilliantly lit chapel and wooden passageway for Chris Ofili's art at the 2003 Venice Biennale; and a steel pavilion for Oslo's Nobel Peace Center [RECORD, September 2006, page 122]. His Museum of Contemporary Art in Denver opens this month.

Adjaye's work negotiates between styles and influences from North and East Africa, the Middle East, and Japan, with North Africa currently predominating. His "ur-forms," cultural historian Stuart Hall writes in *Houses*, are "thick, dark walls or heavily walled exteriors with eyelets and apertures of brilliant interior light." Halls adds that Adjaye is an assimilationist committed to the fragmentary character of modern urban life: "the fluid, the diverse, inclusive, flexible, multi-use, contradictory."

Adjaye's mostly low-budget houses, though rooted in place, are cosmopolitan, sparse but sensual, serious but accessible. His Fog House combines the solid and transparent; Swarovski House delights in both the old and new. Adjaye's houses—part scenographic, part abstract—are modern but inspired by vernacular forms. They uncouple form and function and Modernism's linkage of interior and exterior space. Elektra House's black, thick-walled exterior conceals a light and expansive interior; the roughcast mirrored windows of Dirty

House give no hint of the luminous studio within.

In recent years, Adjaye, who now heads a 40-person London-based firm, has made a transition to works of a more civic nature, as seen in the 10 projects described in *Making Public Buildings*. The book's central drama lies in the tension between Adjaye's professed commitment to the public realm and the sometimes awkward conditions his London buildings impose on the civic spaces around them. The siting of the angular Stephen Lawrence Center (2007), for instance, diminishes the chance that "a wonderful range of human activity," to use Adjaye's phrase, can occur in the adjoining plaza. Other times, Adjaye's rhetoric rings true. Unlike his notoriously blank-walled Elektra House, his public buildings tend to evince openness and transparency while achieving a sympathetic relationship to the street. These qualities come across most vividly in his design for the soon-to-be-completed Wakefield Market Hall, which promises an airy, canopied square to complement a bazaar of retail and food stalls. One is left with the overall impression of an architect striving to make spaces that, he says, "engage very directly with human activity," but whose interventions sometimes contradict this goal.

Unfortunately, the book's illustrations aren't geared to showing public spaces. The pages of only one of the five built projects, those devoted to the Whitechapel Idea Store, break free from the standard

sequence of plans, sections, volume assemblies, and elevations to convey a clear sense of how people use the finished building. A gallery of images of the Whitechapel Idea Store, depicting people browsing stacks, enjoying a dance lesson, and crowding the sidewalk, provides what the technical drawings cannot: a glimpse of the unpredictable human interaction for which Adjaye seeks to "set the stage." Elsewhere in the book, signs of life are noticeably absent, a disheartening trait for any investigation into making public buildings. *Ben Fried and Andrea Oppenheimer Dean*

**Lewis.Tsurumaki.Lewis: Opportunistic Architecture**, by Paul Lewis, Marc Tsurumaki, David J. Lewis. New York: Princeton Architectural Press, 2008, 192 pages, \$40.

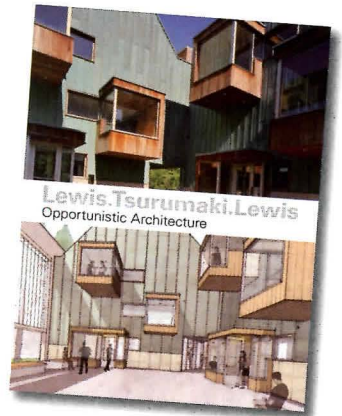

In a profession enthralled by the idea of the alternative, trying to be an outsider gets to look like joining the in-crowd. Everybody's got an "other architecture"—but the firm



## Books

Lewis.Tsurumaki.Lewis [RECORD, Design Vanguard, December 2000, page 116] is something else.

*Opportunistic Architecture* is an understated monograph from a firm that knows how to put understatement to good use. Founded in 1997 by Marc Tsurumaki and twin brothers Paul and David Lewis, much of LTL's completed work has been refurbishment of existing spaces, many in New York. The firm has learned to work within the confines of the railroad plan, shaping seductive surfaces, often of simple materials, into compelling forms with accents lending an element of surprise. The wraparound bamboo dining room of Tides Restaurant on New York's Lower East Side, for example, gives way to a dramatic ceiling with shoals and eddies of massed bamboo skewers, like an overhead tidal pool that turns the small interior upside down.

But LTL can work at the large scale, too. New Suburbanism, a development proposal for the San Francisco Museum of Modern Art, places suburban houses on top of "big box" retail facilities. Even more ambitious, Park Tower combines commercial and residential space with interior ramps allowing cars to drive through the building, from bottom to top. Both of these concepts are so nifty, it's surprising they haven't been thought of before—although they more or less have: Drive-through buildings have been on the boards since at least Matte Trucco's 1922 Fiat factory in Turin, Italy, and putting houses above shopping is merely the redaction of the mixed-use gospel.

The book proffers some "Tactics for an Opportunistic Architecture," but LTL seems to be driven by improvisation and instinct as much as by theory or principle. The firm makes easy but not avid use of digital design. If their modesty puts one in mind of a slightly older, more reserved notion of an "other" Modernism, that's not to say they

risk being tepid, since their casual, intuitive process is so consistently allied with a preference for striking design. *Ian Volner*

**AA Projects Review 2007**, edited by Thomas Weaver, et al. London: Architectural Association, 2007, 240 pages, \$28.

The Architectural Association was founded in the mid-19th century by two young

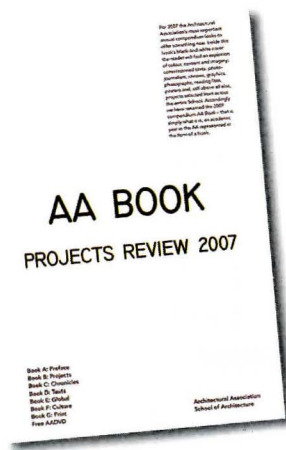

English architects, Robert Kerr and Charles Grey, described by their colleagues as "troublesome" for disrupting business as usual. *AA Projects Review 2007*, a provocative anthology of new student and faculty work, indicates that the animating spirit of this influential and unconventional school hasn't changed much.

Deceptively compact, this paperback contains an overwhelming amount of valuable information. It showcases 745 illustrations of student projects, along with texts and graphics related to the school's program of distinguished lectures and juried exhibitions. Tucked into the book's back flap is a DVD with additional text and graphics.

*AA Project Review 2007*, a good starting point for comprehending the school's controversial identity, offers unsettling evidence of a radical experiment in architectural education. Students receive

instruction in basic architectural principles through a rigorously unorthodox, cross-disciplinary study of history, theory, and media emphasizing that architecture is as much the product of complex layers of dynamically changing data as of building materials. While this "group snapshot" shows only scant evidence that students learn the "nuts and bolts" of architectural practice, lively explorations of utopian-sounding theories abound. For example, one project in "cinematic architecture" features a critical consideration of Jean-Luc Godard's film *Contempt* as a conceptual template for designing an island resort. One photograph frames a lecturer with the phrase "critical utopia" on a whiteboard behind him.

Is there a common link among these contributions from 500 students from 60 countries and from an international faculty? Nearly all the projects in this exhilarating year-book illuminate the junction where earthbound critical thinking bears fruitfully on airy utopian visions. *Norman Weinstein*

**Bohemian Modern: Living in Silver Lake**, by Barbara Bestor. New York: ReganBooks/Harper Collins, 2006, 261 pages, \$35.

Silver Lake, along with its adjoining Los Angeles neighborhoods, has been a haven for creative nonconformists since the beginning of the 20th century. It has been a home to early film-industry innovators, intellectuals, political radicals, gays, and a host of artists and designers. Silver Lake also continues to be a ground zero for architectural innovation for low-cost structures. *Bohemian Modern* maps the social, cultural, and architectural landscape of Silver Lake through a series of lively narratives celebrating the community and its creative energy. Barbara Bestor knows the territory well, having lived there as a student, a young graduate in architecture, and now a single mother and professional.

Silver Lake was where R.M. Schindler, Richard Neutra, and other early Los Angeles Modernists produced some of their most innovative

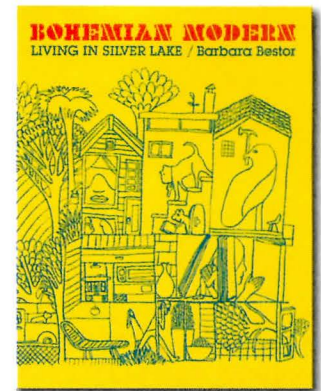

houses for clients of modest means but open minds. These houses are still lovingly inhabited, and their inventive spirit continues to inspire designers. From its birth, Modernism in Los Angeles was an indigenous affair that developed independently from and parallel to European orthodoxies. *Bohemian Modern* shows that this independence from accepted conventions continues to this day. Bestor presents work by the early "masters" alongside that of a current generation that includes Escher GuneWardena, Ball-Nogues, and the author herself, and she underscores the role of garden design and outdoor living in Silver Lake domesticity. However, the real subjects of her book are the area's residents, a convivial community of architects, designers, artists, photographers, cinematographers, composers, restaurateurs, shop owners, children, and pets. The reader finds here great places to eat, drink, shop, socialize—and even a recipe for a "Tri Star Cocktail." The big story is how architecture and a well-designed environment promote creativity and community.

*Bohemian Modern* is a non-conformist mirror of nonconformist Silver Lake. Its layout is wildly collageist and its text lighthearted and refreshingly free of pretense and theoretical rhetoric. If, as the author writes, "The intent of this book is to capture a glimpse of the energy of the community," she has certainly succeeded. *John A. Loomis*



# Professional liability insurance: When to get serious

## Practice Matters

By Casius Pealer

The decision to buy professional liability insurance is a watershed moment for most architects and young firms. It often means that the firm has been awarded a project at a significant scale or with a significant budget, or that a client has contacted the firm with concerns about a particular project. Or it may simply mean a firm is getting serious about the future.

Professional liability insurance is coverage that protects an architectural firm and its employees against claims alleging negligent acts, errors, or omissions in the performance of architectural services. This is different from commercial general liability, or CGL, insurance, which covers the types of accidents or property damage that could happen at any business. CGL policies are relatively standard regardless of the type of business and usually exclude professional liability claims. In contrast, professional liability policies are as specialized and diverse as the variety of professional practices that exist.

### Why firms "go bare"

According to the insurer CNA/Schinnerer, each year between 1994 and 2005 there were between 15 and 21 professional liability claims filed for every 100 firms. And yet, architects who are starting a firm on their own often don't get insurance either because they think

*Casius Pealer is an attorney at Reno & Cavanaugh in Washington, D.C. He was coeditor of ArchVoices from 1999 to 2005.*

the risk is low on small projects, they believe their assets are so limited that they don't have much to lose, or because their clients haven't required it.

Strictly as a cost-benefit analysis, architects generally overestimate the costs of insurance while underappreciating the benefits. The most valuable benefit of professional liability insurance is coverage for legal costs to defend against a claim. The insurance company can provide a lawyer to help the architect gather and retain necessary documentation, and avoid taking subsequent actions that could weaken the architect's defense. When a claim does go to trial, a small firm can be bankrupted just trying to get a dismissal. Legal assistance may be even more valuable than having coverage to pay for actual negligence.

In addition, professional liability insurers offer ongoing risk management services to insured firms. These include legal review of standard and client-provided contracts, and targeted continuing education on ways to reduce or avoid unnecessary liability.

### What actions result in claims

Many young architects are surprised to learn that an architect can be held liable for the negligence of contractors and others working on a project, or that negligence claims can be based on faulty cost estimates or delays in construction. Claims can also be based on planning or feasibility studies and do not require that the architect be

the architect of record for a project. And, not all clients pay their fees; it is common for an architect who brings a suit to recover fees to be subject to a counterclaim that the architect was negligent.

In general, professional liability claims are more likely to be the result of a failure to manage expectations than due to a spectacular construction failure, particularly where the client has little experience with other construction projects. Their understanding of what comprises an architect's scope of work and the quality and timing of the final product may be unrealistic, but that does not prevent claims from being filed and even going to trial or arbitration.

An architect may be reluctant to explain delays or cost overruns to a client, hoping to "catch up" elsewhere on the project. That lack of communication may result in a bigger surprise for the client. Even where a firm has clear expertise on a certain project type, too many commitments can result in client frustration and lack of trust. These are all examples of situations that can generate professional liability claims without an obvious failure on the part of the architect to design a safe, high-quality building.

### Minimizing costs

A variety of factors go into establishing the premium for a particular

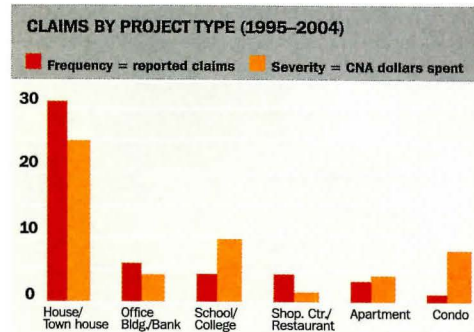

The majority of claims against small firms in recent years came from residential projects.

design firm's policy, including the firm's primary project type, claims history, whether they use standard written contracts, specialty coverage, and the extent of coverage required for prior acts. Project types such as condominiums, which have high litigation costs relative to design fees, or skate parks, which are unique projects with a high propensity for injuries, will typically increase the premium costs. However, documenting and reporting internal practices such as training and structured supervision of employees can demonstrate a lower risk and decrease premium costs. Although the application forms for insurance are often lengthy, completing the form accurately and thoroughly can allow the agent to more accurately assess the risk posed by a firm and justify a lower premium.

The factors in the application allow the agent to determine a fractional number or rate, which is then multiplied by a measurement of the firm's annual billing or total project costs to quantify the annual pre-



# Practice Matters

mium in dollars. When reporting a firm's annual fees for this calculation, architects should subtract costs such as travel or copying, or fees for work on projects that were abandoned before construction and thus do not add to liability. For new firms without a significant history of billing, the multiplier is typically a reasonable estimate of the firm's anticipated billings for the coming year. If the premium creates a financial hardship for the firm, the agent may be able to respond creatively to an individual firm's needs.

## Nontraditional practices

Many young firms are specialized or employ a variety of innovative corporate structures and delivery methods. These can have a surprising impact on professional liability. For instance, some architects design and custom-build their projects. This is often done for small clients and allows the architects to do custom detailing on-site. However, because the professional liability of a contractor is different than that of an architect or designer, work built by the architect is not covered under the standard architect's policy. Although many insurance companies offer a design-build endorsement for architecture policies, these only cover issues that arise from the design work done on a design-build project where the builder is a distinct entity. An architect who is personally acting as the builder would need an entirely separate design-build policy.

Or say two architects team up in a joint venture to do a project. Where both parties are licensed professionals, each should have separate insurance coverage, or they may want to get a joint-venture policy specifically covering the work they do together. With a separate policy, liability for any joint projects can then be excluded from the firms' individual policies. Where a young architect and a nonprofessional—an artist or sculptor, for

example—collaborate on a project, the actions of the non-professional may be legally attributed to the architect, but not covered under the standard architect's policy. In this case, the architect may be able to get a simple endorsement to their existing policy that adds the non-professional as a "limited insured."

Also, architects who are not licensed often think that they can-

**ARCHITECTS:** Claims frequency per 100 firms

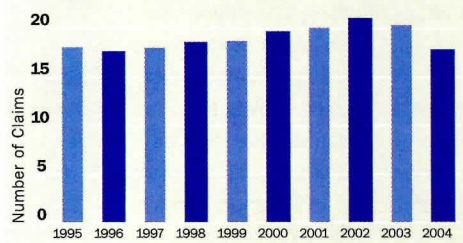

**Although the likelihood of a claim against a firm is low (above), it's still not unheard of. Project owners are most likely to file a claim against a firm.**

**Frequency of Claims by Claimant Identification (1995–2004)**

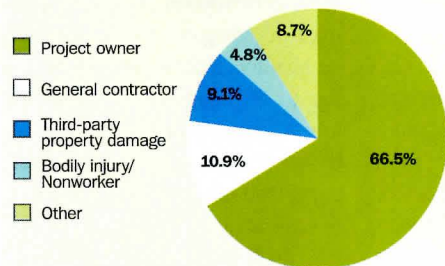

not get professional liability insurance. This is not true. Many nonlicensed professionals, such as appraisers, building inspectors, and even social workers provide specialized services following extensive education and training, and thus seek specialized coverage. Although many insurance companies do limit their specific coverage for architects to only "licensed architects," those companies are likely to have other policies that can cover design work that does not require a license. For instance, a nonlicensed architect doing substantial interior renovations could obtain coverage

as an interior designer, or through a design-build policy if applicable. Alternatively, nonlicensed professionals who can demonstrate some basic level of experience can usually get coverage as "specialty consultants."

## Coverage in nonprofit settings

Increasingly, young architects work full-time in nonprofit settings such as community design centers. But professional liability policies covering architects are often available only to licensed architecture firms as defined by state law, and not to nonprofit corporations with just a few architects providing design services. And while it is possible that a nonprofit's existing general liability policy could cover the organization itself for incidental professional services, the professional providing those services could still be held personally liable for any claim. One solution here is for the nonprofit to acquire what is called a "miscellaneous professional liability" policy. These policies are designed to cover people who are potentially subject to professional liability, but who work in a field that doesn't have individualized professional liability policies. The basic miscellaneous policy is accompanied by an endorsement covering a specific profession. Although "architect" is not usually one of the professions covered in this way, the nonprofit may be able to obtain such an endorsement. Either way, it is worth noting that nonprofits often have coverage for their board members, which is also called "nonprofit professional liability." This kind of policy should not be confused with the insurance needed by an architect who is working as a nonprofit's employee.

## Working by moonlight

Young architects who are consider-

ing starting their own business sometimes take on side projects while employed full-time. This practice is strictly prohibited by most firms, primarily in order to limit the design firm's exposure to potential legal claims resulting from the moonlighting employee's work. However, with careful planning and honest communication, young architects who want to engage in extracurricular activities can do so without creating liability for their primary employers. These employees should first purchase a comprehensive professional and general liability policy in their own names, and should be prepared to provide the employer with the certificate of insurance as proof (this personal policy should also have an explicit exclusion for any work done by the employee on behalf of the employer). The employee should never give an external client even the slightest impression that they are working on behalf of or supervised by their primary employer. No work should ever be done from the employer's office—including e-mails and phone calls. The employee should not use the firm's business card or even a notepad with the firm's name on it. It would also be reasonable for an employer to ask for formal certification of the above prohibitions.

## Believing in the future

Architects are subject to professional liability as a direct result of the higher expectations placed on us due to our specialized education and training. Our work involves complex decisions and responsibilities—designing projects, supervising an office, observing construction, achieving client satisfaction, and ensuring the health, safety, and welfare of the public. Buying insurance is not about avoiding risk, but it is an important part of having the knowledge, the confidence, the resources, and the professionalism to take on and manage multiple risks simultaneously. Firms that take the plunge are optimistic (not merely hopeful) about the future ahead of them. ■



# Snapshot



By David Cohn

At first glance, the two 120-foot-long shading canopies of the Sergio Cardell Streetcar Stop in the coastal city of Alicante, Spain, seem to float over the station platforms like strange, untethered box kites or silvery, squared-off balloons. They are riddled with holes of different sizes that emit light at night and admit cooling breezes in the hot Mediterranean afternoons, and seem to glide between the palms and olive trees of their parklike setting with the same frictionless ease as a moving tram. Only closer inspection reveals a pair of slender columns supporting each box, located asymmetrically along their length, and a pair of tension cables near one end to counterbalance the resulting 72-foot cantilevers.

The station is the first built work of Andrés Silanes, Fernando Valderrama, and Carlos Bañón of the local firm Subarquitectura, members of the first graduating class of the University of Alicante's School of Architecture in 2002. The city council invited them to participate in a hasty competition for the project after local residents mobilized against the original stops proposed by the engineers responsible for the city's expanded streetcar system. Still fresh from their rigorous technical training, the team designed and calculated the daring structure themselves. Stresses are transferred through the 4¾-inch-thick sandwich of the boxes' skin, using exterior steel sheet, slim interior trusses, and the soldered edges of the holes. A handful of cross braces strut diagonally through the box interiors in syncopation with the angled fluorescent lighting tubes.

The station stands in the center of a large traffic circle, which the architects have incorporated into their design, distributing combined seating-light units along its meandering paths, and raising the islands of grass between them into berms, a strategy that both creates a sense of enclosure within the circle and heightens the visual disconnection between the platform canopies and the ground when seen from outside.

With their pockmarked, luminous surfaces and improbable defiance of gravity, the boxes have become an instant icon in this dense peripheral neighborhood of new apartment buildings. For the locals who flock to the café terraces surrounding the stop, the catchphrase is "Meet you at the Swiss cheese!" ■

## A traffic-stopping tram stop floats on air

**The two canopies offer not only shelter, but also a sense of wonderment to local riders.**





# Part of **America's** Landscape

**Pavers**, manufactured by Wausau Tile, complement the viewing area at the Visitors' Center at Mt. Rushmore National Memorial in South Dakota.



"Responding to the needs of our customers has been the guiding principle in all we do."

*Ed Creske, Founder*

800.388.8728

[www.wausatile.com](http://www.wausatile.com)

CIRCLE 37 ON READER SERVICE CARD OR GO TO [ARCHRECORD.CONSTRUCTION.COM/PRODUCTS/](http://ARCHRECORD.CONSTRUCTION.COM/PRODUCTS/)





# Design Vanguard 2007



For our **eighth annual** selection of the world's **top emerging designers**, RECORD finds a diverse group of firms that are committed to **making architecture count**

**L**ooking at this year's Design Vanguard winners, the first things you notice are the graceful lines and intriguing forms of the built work. You think: accomplished, thoughtful, pleasing. But dig a little deeper, and you'll discover that this year's group of 10 emerging designers is doing more than just making appealing architecture. Without a lot of fanfare or noise, these practitioners are engaging with issues larger than just form-making and are addressing audiences beyond the world of architects.

Several of the firms are deeply involved in housing, developing strategies and designing projects for multifamily residences. Sebastian Mariscal's commitment to this area started early in his career when he worked for his father, a public-housing architect in Mexico City. Tatiana Bilbao also forged her career in the public-housing sector, working for Mexico City's Urban Housing and Development Department before launching her own firm. In the Netherlands, Kempe Thill has applied its notions of "specific neutrality" to a number of social housing projects.

For Sou Fujimoto, engagement has meant designing for children with mental and emotional problems. In a pair of facilities on the northern island of Hokkaido, Japan, Fujimoto has created quirky floor plans that let the children find their own uses for unusual spaces. In Spain, the three partners in estudio.entresitio have designed a series of remarkable health centers that bring a kind of architectural poetry to a building type better known for dreariness.

Pei Zhu's work in Beijing reaches out in a different way—searching for connections between Modernism and an ancient culture undergoing rapid change. By engaging the social, political, and cultural contexts beyond their buildings, this year's Design Vanguard firms are imbuing their work with deeper meaning. *Clifford Pearson*

## FEATURED FIRMS

Studio Pei-Zhu	p.68
Leven Betts Studio	p.74
estudio.entresitio	p.78
Höweler + Yoon Architecture	p.82
Moongyu Choi+GaA Architects	p.86
Tatiana Bilbao/mx.a	p.92
Sebastian Mariscal Studio	p.96
Sou Fujimoto Architects	p.102
BROISSINarchitects	p.108
Atelier Kempe Thill	p.114





## Studio Pei-Zhu commits to an energetic urbanism in modern China

By Andrew Yang

**Architect:** Studio Pei-Zhu

**Location:** Beijing, China

**Founded:** 2005

**Design staff:** 25

**Principals:** Pei Zhu, Tong Wu

**Education:** Zhu: the University of California, Berkeley, M.Arch., 1997; Tsinghua University, Beijing, M.Arch., 1991; Wu: Tsinghua University Academy of Art and Design, Beijing, M. Literature, 1997

**Work:** Zhu: Studio Pei-Zhu, 2005–present, Urbanus, 2001–3; Wu: Studio Pei-Zhu, 2005–present; Art and Design, 2003–7

**Key completed projects:** Digital Beijing, Beijing Olympic Park, 2007; Blur Hotel/Hotel Kapok, Beijing, 2006

**Key current projects:** Publishing House, Beijing, 2008; Cai Guoqiang House, Beijing, 2008; Guggenheim Museum Beijing, Beijing, completion date unknown; Guggenheim Art Pavilion, Abu Dhabi, 2011.

**Web site:** www.studiopei-zhu.com

Amid the rush to modernize, Chinese cities are becoming homogenized and losing their distinct identities,” laments Pei Zhu, principal of the eponymous office, Studio Pei-Zhu, which he started in 2005, after leaving Urbanus [RECORD, December 2005, page 100], the firm he cofounded in 1999. “Our studio seeks to create architecture that reflects contemporary Chinese culture, including its roots and contradictions. We want to energize urban districts.”

Studio Pei-Zhu is enjoying some high-profile commissions right now. Earlier this year, Zhu was on a roster of well-known architects—Zaha Hadid, Frank Gehry, and Jean Nouvel—to design a piece of a multibillion-dollar museum complex in Abu Dhabi. Zhu has also been retained by the Guggenheim Foundation to design a future outpost for the foundation in Beijing. Although the project is still under wraps, Zhu reveals this much: “We have come up with an almost invisible building. Most of the structure will be fabricated in a factory, and most of the structure won’t touch any of the old buildings. It’s almost floating in a courtyard, and it can be installed on the construction site without any damage to the ground.”

In a way, the idea of an “invisible” building is a continuation of the urban research that influenced an earlier project, the Blur Hotel (since renamed Kapok), a renovation of a 1980s building east of the Forbidden City. To Zhu, that project was indicative of the insensitive development that has disrupted the traditional hierarchy of the city plan. He reimagined the envelope with a fiberglass-reinforced grid so that it recedes from the foreground, blurring into a translucent block along the traditional streetscape.

Regardless of what will eventually be built for the Guggenheim, the ongoing project is emblematic of the kind of approach that characterizes Zhu’s work. “I have turned the direction of my studio more toward architecture and research,” he says of his post-Urbanus practice. “We’re not just doing projects from an urban-planning point of view; we are using our architecture projects to explore problems.”

One of the projects that he took with him from Urbanus is the Digital Beijing building, which will be the control and data center for the 2008 Olympics and will then serve as an exhibition hall once the games are over. In the ongoing process of building Beijing, Zhu’s approach seems to be a bit more balanced and nuanced than the government’s approach to

urbanism, which currently favors large, iconic buildings. His preference is for contemporary structures that leave only a light mark on the cityscape. “There is still something missing in the city. Architecture is not just a tool for urban development,” says Zhu. “Architecture can be very interesting, something for people to enjoy. And it can be something to help people relax; it shouldn’t just be serious. Everyone shouldn’t focus just on economic growth. I want to create buildings that help people enjoy themselves, to have a sense of an experience beyond the physical aspect of the architecture.” ■

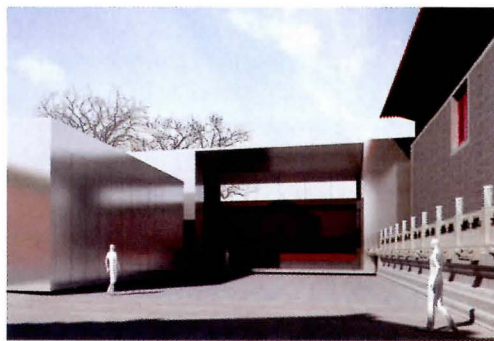

The Guggenheim Foundation commissioned a concept for an addition to the Huang Shi Cheng archive.

Shanghai-based Andrew Yang is a journalist and design consultant for the launch of 100% Design Shanghai.



**Blur Hotel/Hotel  
Kapok, Beijing**

Studio Pei-Zhu transformed this 1980s office building located near the east gate of the Forbidden City into a chic boutique hotel. Now named the Hotel Kapok, the project reenvisioned the building as a dynamic urban space, clad in a translucent, greenish grid of fiberglass, which is meant to dissolve the banality of the original structure and create a lanternlike presence on the street.





**Art Pavilion, Saadiyat Island Cultural District/Biennale Park, Abu Dhabi**

Part of an ambitious new cultural complex in Abu Dhabi, the Guggenheim Art Pavilion sits between a new cultural district and a Biennial Park. By raising the structure and leaving the exposed public space below, the building is designed as a transition space, with largely open-plan exhibition galleries above. This facilitates a connection between the cultural district and the park.

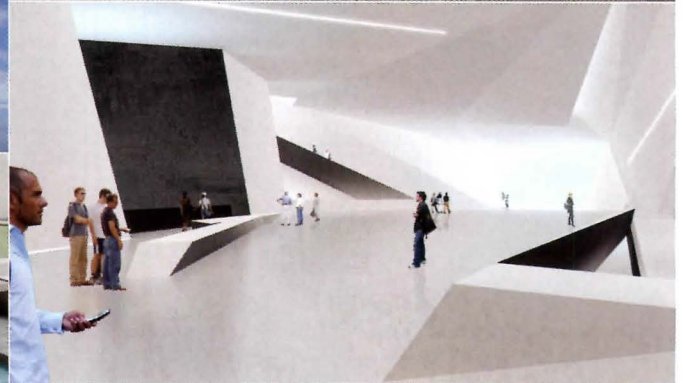

**Cai Guoqiang House Renovation, Beijing**

For a new home for one of the major Chinese artists working today, Studio Pei-Zhu was asked to renovate and add to an existing structure in a traditional Beijing courtyard home, known as a *siheyuan*. After restoring the existing structures and fitting out a Modern interior within, the new buildings will be built onto the site without damage to the existing structures, with minimal visual impact, creating a respectful balance between new and old.

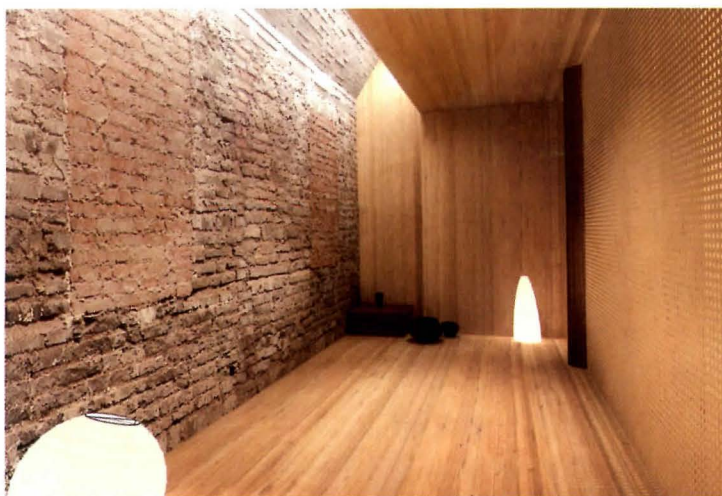



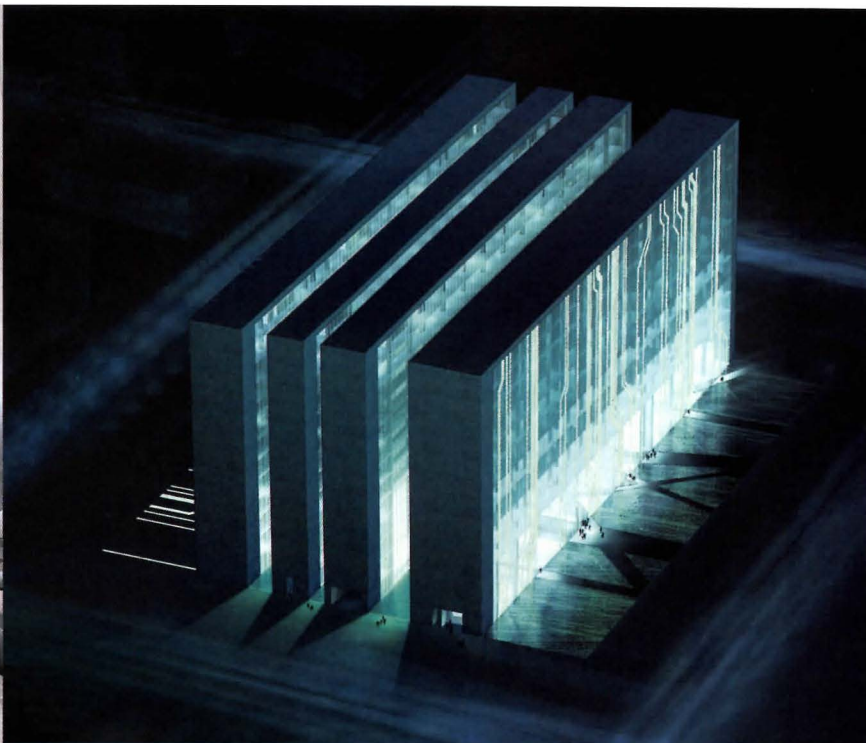

## Digital Beijing, Beijing

A repository of digital data and communications services to be used during the 2008 Olympics, this building resembles an integrated circuit board, inspired by the rise of digital technology. One of the first projects to be completed for the event, the building will also house an exhibition presenting a "virtual" Olympic Games.

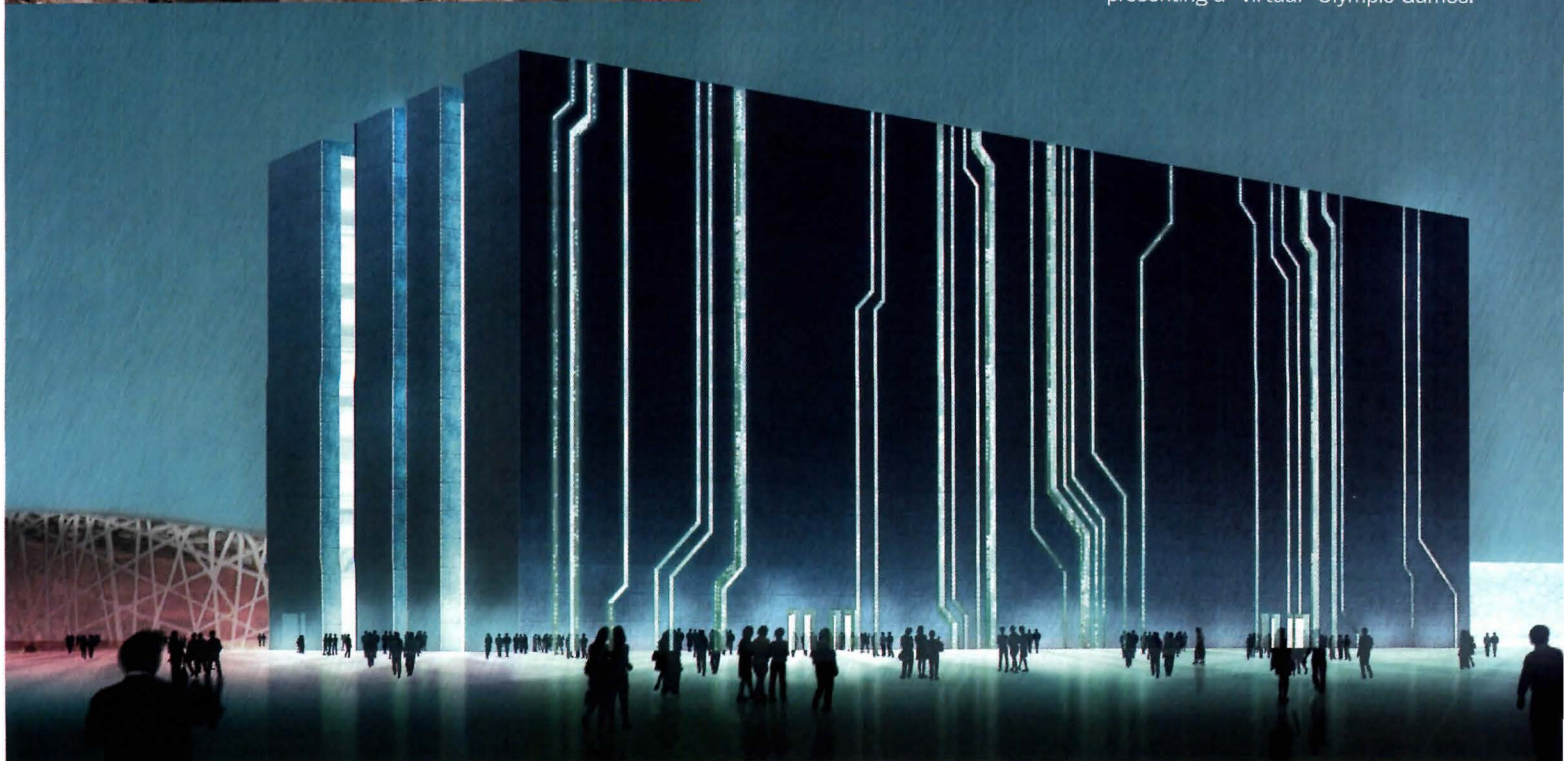



## Ningbo Book City, Ningbo

In this competition entry to create a new library complex for the city of Ningbo, Studio Pei-Zhu proposed a new connection between the riverfront site and the city center. A series of horizontal volumes housing the main book collections alternates with “voids”—permeable spaces offering visitors physical and visual connections to the riverfront.

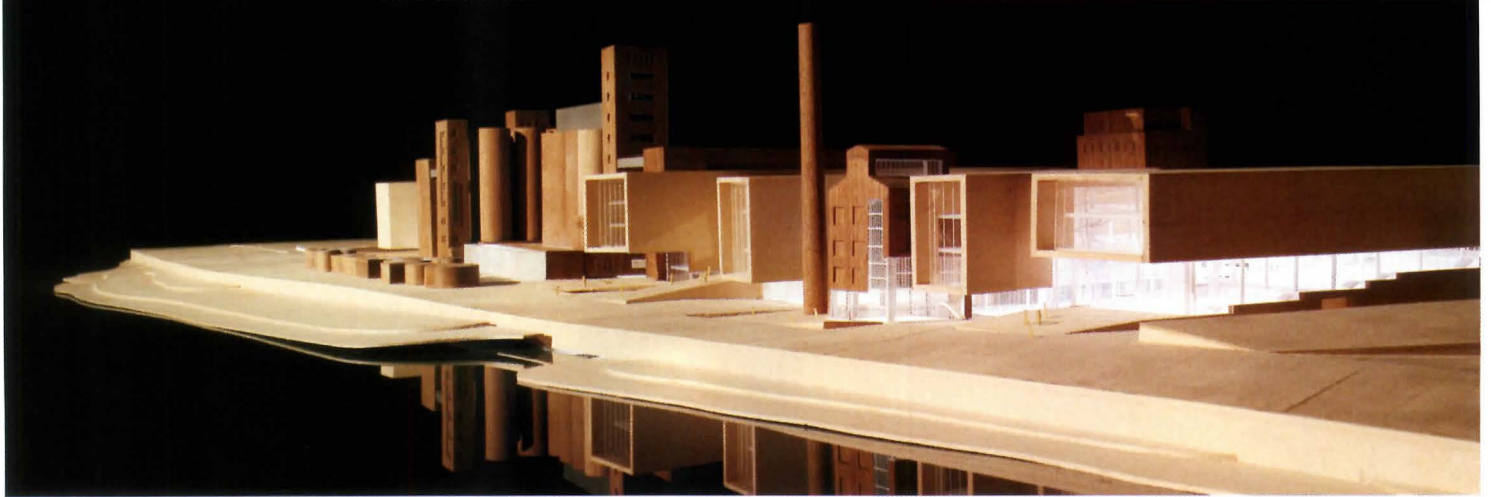
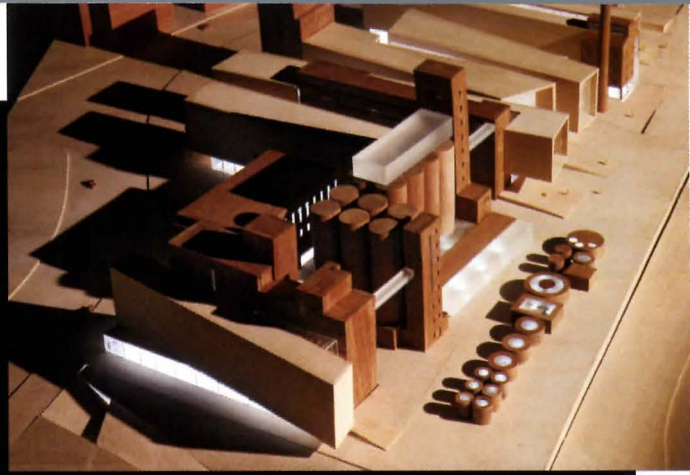

## Publishing House, Beijing

This will transform an existing 12-story office block into a series of dynamic spaces for working, learning, and shopping. To do this, the architects extended and cantilevered certain floors, creating common areas for socializing, as well as a variety of vertical paths between floors. The goal is to create a “micro-city” with a rich diversity of activities happening inside.

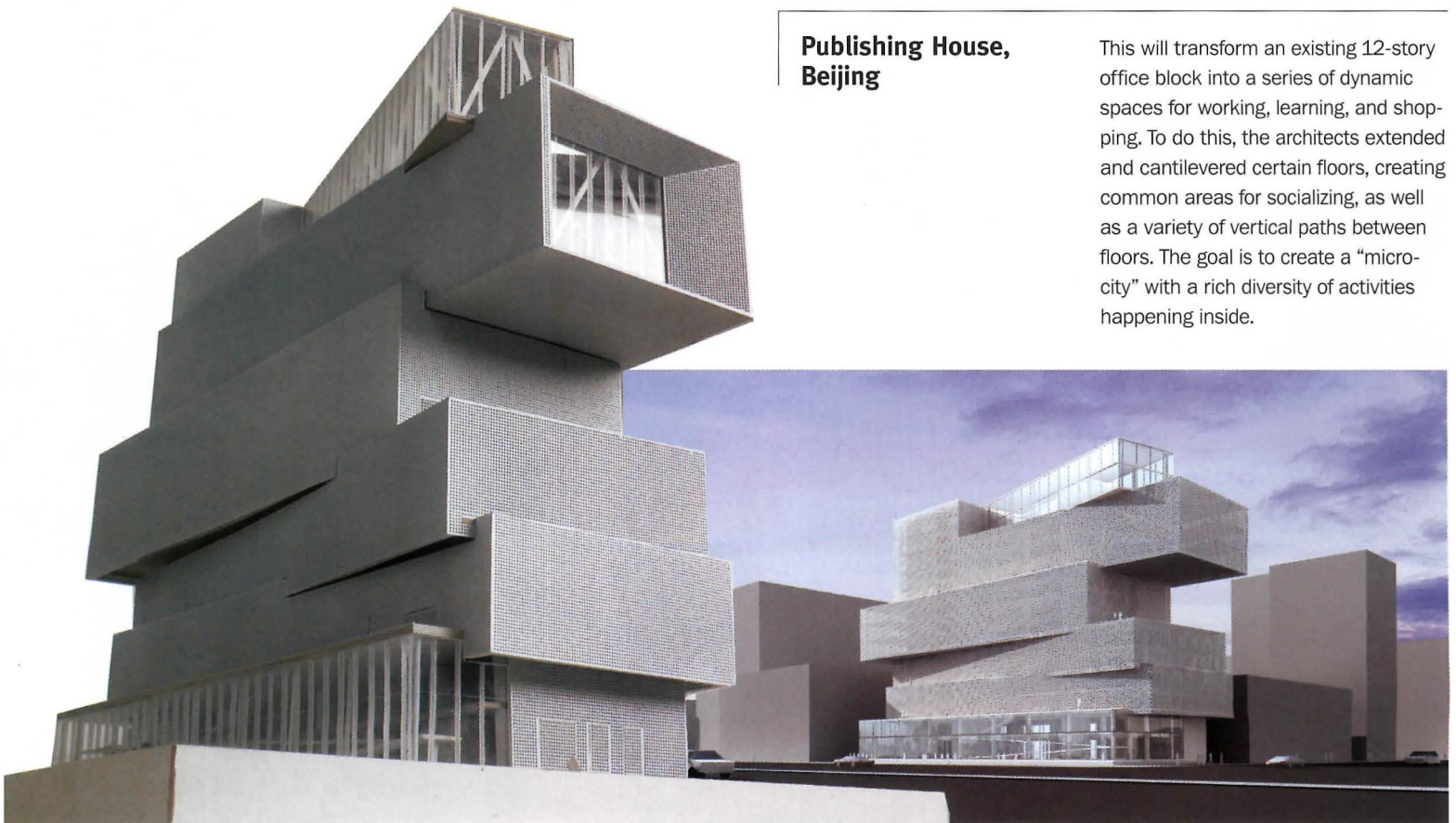





**Xisi Bei Historical Area, Urban Design Concept, Beijing**

Studio Pei-Zhu studied the Xisi Bei area of Beijing and proposed a series of urban interventions aimed at reviving the old and often poorly maintained courtyard houses, or *hutongs*. By introducing a series of Modern mid-rise buildings in strategic locations in the neighborhood, the architects hope to create the kind of density and spaces for new functions needed to support a vibrant community, while allowing the *hutongs* to be rehabilitated.

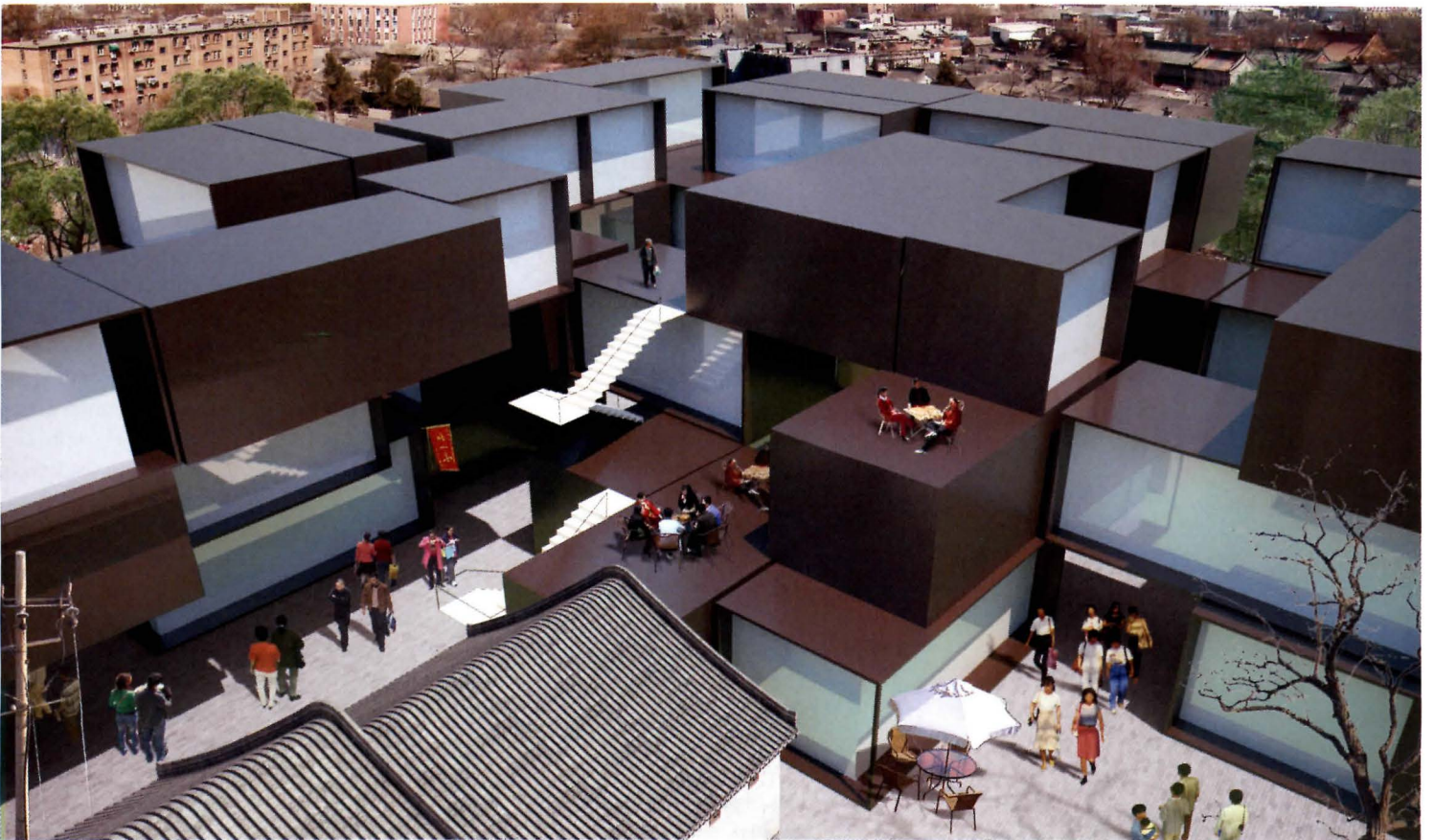





## Leven Betts Studio crafts its project-specific solutions at a variety of scales

By Joann Gonchar, AIA

**Architect:** Leven Betts Studio Architects  
**Location:** New York City  
**Founded:** 1997  
**Design Staff:** 9  
**Principals:** David Leven, Stella Betts  
**Education:** Leven: Yale University, M.Arch, 1991; Colgate University, B.A. Fine Art, 1986; Betts: Harvard University Graduate School of Design, M.Arch, 1994; Connecticut College, B.A. Fine Art/Philosophy, 1988  
**Work history:** Leven: Practice—Vito Acconci Studio, 1996; Kern Rockenfield Metal Fabricators, 1995–96; Academic—City College of New York, 2003–present; Syracuse University, 2007; Betts: Practice—Wurmfeld Associates, 1996–97; Fussell Construction, 1994–96; Academic—Parsons The New School of Design, 2004–present; Syracuse University, 2007  
**Key completed projects:** Piranesi Exhibition, Cooper Hewitt, National Design Museum, New York City, 2007; CC01 House, Columbia County, N.Y., 2006; Mixed Greens Gallery, New York City, 2005; Catskills House, Stone Ridge, N.Y., 2005; Penthouse Roof Addition, New York City, 2004; Loft Renovation, New York City, 2004; Penthouse Apartment, New York City, 2003; Lobby, New York City, 2002; Furniture Showroom, New York City, 2002; EMR Printing Plant, New York City, 2000  
**Key current projects:** WE House, Hurley, N.Y., 2007–8; CC02 House, Columbia County, N.Y., 2007; Rococo Exhibition, Cooper Hewitt, National Design Museum, 2008; Penthouse Triplex Apartment, New York City, 2007–8; Town House Renovation, Brooklyn, N.Y., 2007  
**Web site:** www.levenbetts.com

Employing what they call a “research-and-diagram-based process,” David Leven and Stella Betts, of New York City–based Leven Betts Studio, have been creating environments that are inventive, spare, and elegant for the past decade. Their method involves scrutiny of site, program, and material, to create an organizational framework and physical structure. “The process is not always so legible in the final product,” says Betts. However, it provides the basis for a project-specific “patterning system and a formal language,” adds Leven.

Though such talk might sound like the stuff of paper architecture, the partners are well-grounded in the realities of construction. Leven’s resume includes a stint in a metal fabrication shop, while Betts spent two years as a project manager at a construction firm. “Out of graduate school, my agenda was to understand how things were put together,” she says.

The firm’s early commissions were primarily for furniture, with the husband-and-wife team fabricating many of the pieces. On occasion, the pair will still perform “soft” construction tasks. In a house completed last year in Columbia County, New York, they installed metalwork and assembled polycarbonate walls. “We are not really set up for design-build, but once in a while we have to get our hands on something,” says Leven.

Leven and Betts say that the design of the house was inspired by the surrounding landscape. They used the crop lines created by cultivation of the land to generate the elongated footprint of house, patio, and garage and guide their selection of materials, such as the corrugated-metal exterior sheathing. Similarly, in their scheme for a Manhattan gallery, the architects took their cues from the irregular geometry of an existing beam-and-column structure, creating a glowing, gently zigzagging suspended ceiling of aluminum flat bar and translucent acrylic [RECORD, August 2006, page 175].

In addition to other realized projects that include a furniture showroom [RECORD, February 2004, page 160] and a small printing plant, the studio designed the current Piranesi show at New York City’s Cooper Hewitt. The installation has received acclaim for its sensitivity to the exhibition’s content and the architecture of the museum’s late-19th-century home. The partners are now trying to turn the corner into institutional work, recently completing a proposal for an affordable-housing complex on Long Island featuring 45 duplex apartments arranged around a common green.

One theme that has long fascinated Betts and Leven is the relationship between the car and the city. In 2003, the firm won a Chicago Architecture Club competition for design of a 1,000-car automated parking garage. The team proposed spanning that city’s Kennedy Expressway with a glazed structure that would also provide a café, a vertical garden, and a route for pedestrians and cyclists to cross the multilane highway. Since winning the competition, the couple has included automated parking facilities in several other proposals, as both revenue generator and public amenity. When Leven Betts gets the opportunity to translate these ideas into bricks and mortar—or more likely polycarbonate, glass, concrete, and steel—the urban environment should certainly benefit. ■



Proposed Cedarhurst Housing on Long Island features both private and shared realms.





### CCO1 House, Columbia County, New York

This weekend home takes its cues from its setting and the linear pattern etched into the surrounding fields by years of farming. The architects used these furrows to define the layout of the house, enclosed by mostly solid, east and west walls, and clad in corrugated metal. Interior elements, such as the kitchen counter that seems to float, are also generated from the crop-line diagram. Short end walls of glass and polycarbonate frame views of the landscape that inspired the design.

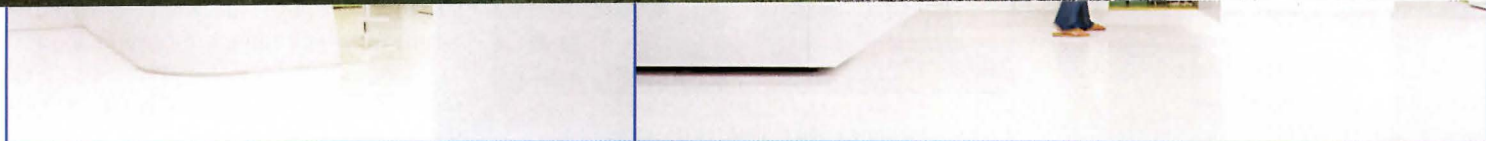





City Library Addition As part of their entry in the interna-

## estudio.entresitio reinterprets Spanish traditions with a sensitive touch

By David Cohn

**Architect:** estudio.entresitio

**Location:** Madrid, Spain

**Principals:** José María Hurtado de Mendoza Wahrolen, María Hurtado de Mendoza Wahrolen, César Jiménez de Tejada Benavides

**Education:** José María Hurtado de Mendoza Wahrolen: Spanish Academy Scholarship, Rome, 2004; University ETSA Madrid, 1999; Erasmus Scholarship, Università La Sapienza-Università di Tor Vergata, Rome, 1996–97; María Hurtado de Mendoza Wahrolen: Spanish Academy Scholarship, Rome, 1996–97; University ETSA Madrid, 1993; César Jiménez de Tejada Benavides: Master of Advanced Architectural Design, MSAAD, as Fulbright Scholar, Columbia University, New York, 2000; University ETSA Madrid, 1992

**Work history:** Wahrolen (José): Practice—Rafael Moneo Architects, Madrid 1999–2000; Academic—codirector, summer seminars, Alcalá University, Madrid, 2000; Wahrolen (María): Academic—professor, University ETSA Madrid, 1998–present; exhibition curator, codirector, summer seminars, Alcalá University, Madrid, 1999 and 2000; Benavides: Academic—professor, University ETSA Madrid, 2000–present

**Key completed projects:** Health-Care Center, San Blas, Madrid, 2007; Health-Care Center, Daimiel, Ciudad Real, 2007; Two Row Houses, Dehesa

de la Villa, Madrid, 2006; Childhood Drug-Rehabilitation Center, Chinchón, Madrid, 2005; Health-Care Center, Minglanilla, Cuenca, 2003; 12 Social Houses, Villarobledo, Albacete, 2000

**Key current projects:** 43 Social Houses, Almuradiel, Ciudad Real, 2007; Renovation of Glass Pavilion, Casa de Campo, Madrid, 2008; Health-Care Center, Usera, Madrid, 2008; 22-Story Residential Tower, Vallecas, Madrid, 2009

It's a considerable challenge to make a large, windowless, one-story floor plate of a neighborhood health clinic into a tectonic play of solids and voids, somehow drawing daylight into the interiors from 14 small terraces, and, all the while, staying within a tight budget and adhering to the exacting standards of a public project. The clinic, in the working-class Madrid neighborhood of San Blas, was designed by the three principals who make up estudio.entresitio—brother and sister, María and José María Hurtado de Mendoza Wahrolen and César Jiménez de Tejada Benavides.

Conceived as a prototype, the softly textured exterior of board-formed concrete is enlivened by an irregular profile, created by the towers enclosing rooftop mechanical equipment. With interior planes of cobalt-blue tile, the towers function as reflectors beside the terraces, forming a connection with the exterior along the vertical rather than the horizontal axis.

The three architects founded entresitio in 2000, after graduating from Madrid's School of Architecture, where both María and César now teach. For the more complex program of a medical diagnostic and treatment center in Daimiel, the architects used a series of long parallel terraces. The tightly woven plan reflects José María's experience working under Rafael Moneo on Madrid's Maternity and Pediatrics Hospital [RECORD, October 2004, page 156]. The architects sheathed the exterior in a double skin of louvers, exquisitely constructed from strips of galvanized, perforated, and folded steel sheet mounted in steel frames, with fire-engine-red steel-sheet cladding behind them to create a sense of depth, liveliness, and intrigue. For a public housing project now under construction in Madrid, they deployed diagonal symmetries in the plans for the different building elements—tower, block, and base—to help create a vibrant pattern of openings across the zinc-finished facades, which seem to enclose the volumes like wrapping paper.

In all these projects, entresitio's approach is frankly anticontextual: the firm's work aims to stand out rather than blend in. Yet rather than resorting to showstopping displays of formal expression, they develop their designs from within the technical terms of the problem at hand, from the building program and its construction, which they abstract into an

apparently limited but endlessly fascinating formal game. This "disciplinary" approach, as it is called by Madrid architects Luis Mansilla and Emilio Tuñón, has been one of the identifying characteristics of Spanish architecture since the 1950s. It is also an approach ideally adapted to the contradictory demands for striking form and functional efficacy on Spain's grueling competition circuit. ■

David Cohn is RECORD's Madrid-based international correspondent.

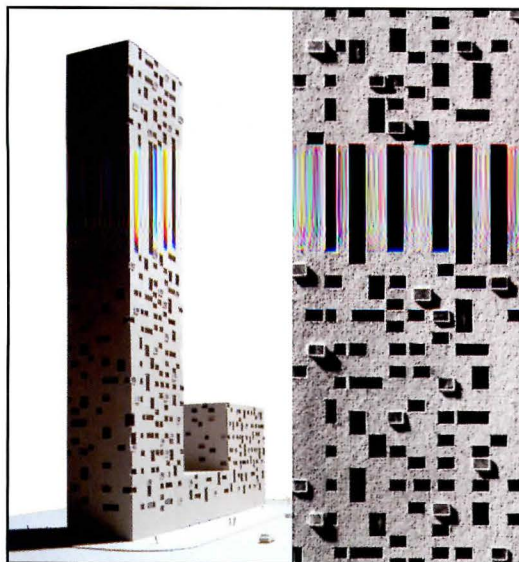

Madrid's Maternity and Pediatrics Hospital.





**Diagnostic and  
Treatment Center,  
Daimiel, Ciudad Real**

Four long patios (plus a smaller one near the entry) give a sense of monastic interior focus to this public facility. Its exterior windows are protected by an outer mesh of perforated-steel louvers, which give the building an intriguing abstract presence. The center provides specialized out-patient services, from an emergency ward to physical therapy, allergy treatments, and dental surgery, saving residents the ½-hour trip to the nearest hospital.





## Public Health Center, Minglanilla, Cuenca

The Minglanilla clinic adopts the courtyard-centered building tradition of its rural location. Visitors cross a patio planted with ancient olive trees to enter the building, branching off to the emergency unit on one side and two levels of outpatient services on the other. The patio entry is bridged by a suite of staff rooms. The architects used simple planar stucco volumes with a minimum of openings; the roofs are finished in porous concrete in a matching color, with waterproofing below.



## Urban Renovation, San Andes, Jaén

For a dense program of small starter apartments on a tight site with a 40-foot slope, entresitio located parking on grade with the upper access, with housing above and below. The plans are interconnected, broken loops that introduce intricate narrow patios, appropriate to Jaén's hot southern climate, without breaking the continuity of the floor plate. The building decreases in density above the parking level to maximize light.

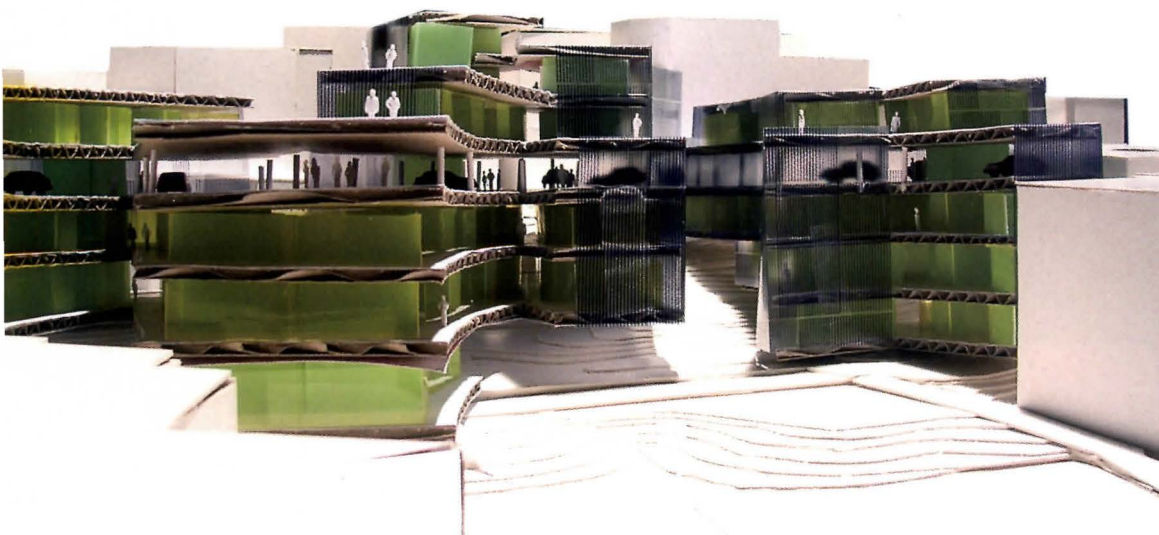





**Municipal Health Center,  
San Blas, Madrid**

A windowless exterior of board-formed concrete, with fortresslike mechanical towers and a protected entry court, together with 14 interior patios, transform the simple program of a one-story public medical clinic into a play of solids and voids that draws on Spain's rich architectural tradition.



COURTESY ENTRESITO (OPPOSITE, LEFT); ROLAND HALBE (THIS PAGE)



# Höweler + Yoon blurs edges between art and architecture with digital aplomb

By Suzanne Stephens

**Architect:** Höweler + Yoon

Architecture

**Location:** Boston

**Founded:** 2005

**Design staff:** 4

**Principals:** J. Meejin Yoon,  
Eric Höweler

**Education:** Yoon: Harvard Graduate School of Design, M.Arch and Urban Design, 1997; Cornell University, B.Arch., 1995; Höweler: Cornell University, M.Arch., 1996; B.Arch., 1994

**Work history:** Yoon: Practice—Dean Wolf Architects, New York City, 1998–2000; MY Studio, Cambridge, Mass., 2001–present; Academic—MIT, 2005–present; Höweler: Practice—Diller Scofidio + Renfro, New York City, 2002–5; Kohn Pedersen Fox, New York City, 1995–2002; Academic—MIT, 2006–7

**Key completed projects:**

Outside-In Loft, Boston, 2007; *Low Rez Hi Fi*, Washington, D.C., October 2007; *White Noise/White Light*, Athens, Greece, 2004.

**Key current projects:**

Triple House, McLean, Va., 2008; Trio, Palisades Park, N.J., 2007; Building 2345, Washington, D.C., 2008

**Web site:** www.hyarchitecture.com

Two young architects, Eric Höweler and J. Meejin Yoon, stepped into the architectural limelight in 2004 not with a building but an interactive LED light installation, created for the Athens Olympics. *White Noise/White Light*, constructed of hand-fabricated fiber-optic fixtures, was installed on the side of the Acropolis only for 30 days, but long enough for the Boston-based firm to be noticed by architectural aficionados. In May 2005, the designers mounted the installation at MIT—where they both teach—for a week for the inauguration of the new president, Susan Hockfield. Soon a private developer in Washington, D.C., commissioned them to create a signage, light, and sound installation, *Lo Rez Hi Fi*, for an office building's street front and lobby [RECORD, November 2007, page 190].

In their architectural work, Höweler and Yoon seek to unite—and blur boundaries between—architecture, art, and landscape in a way that takes advantage of new electronic media. The two met in the early 1990s in the B.Arch. program at Cornell, a school known for teaching students to draw and to solve functional problems based on a strong morphological analysis. This is a long way from working with computational fabrication tools, CAD/CAM, and basic electronics for sound and light installations. “I never thought we’d be do-it-yourselfers in terms of electronics and fabrication,” says Yoon. The path to digital landscape was not direct. Yoon, who was born in Seoul, Korea, entered Harvard’s Graduate School of Design in 1995 after Cornell. Höweler stayed at Cornell to take his M.Arch., before decamping in 2005 for New York and a job at Kohn Pedersen Fox (KPF). As a result of his work with the firm’s high-rise tower design in Asia, Höweler wrote *Skyscrapers: Vertical Now* (Universe), in 2003.

Yoon had spent time in the New York office of Dean Wolf Architects in 1998 before teaching positions lured her away, first to the University of Toronto, and then to MIT. At MIT, Yoon discovered the thrill of experimentation with digital media when she took a course at the media lab. “MIT taught me fearlessness,” she says. By 2001, Yoon had formed her own office, MY Studio, in Cambridge, Massachusetts, and had begun investigating the intersection between electronics and architecture.

Höweler, still in New York, and Yoon, in Cambridge, married in 2002, the year Höweler left KPF to work at Diller Scofidio + Renfro. “That office provided an intellectual framework for architectural practice. It was so intense and exciting,” he says—“and hard to leave.” But by 2005, it was time to join forces with Yoon: “If you’re going to work 20-hour days, seven days a week, you soon want to spend that energy on your own projects,” Höweler points out.

Since then, the two have taken on work typical of young offices, such as renovations, interiors, and houses. The scale of the commissions is not a problem for Yoon, who, at Dean Wolf, discovered she likes being involved in small-scale, custom-design work. Höweler, however, notes that going from skyscrapers and other large-scale projects to houses was a shock. Yet he values the advantages of a hands-on approach and collective brainstorming possible with an office this size. At this point, the two still seek a convergence between electronic and architectural projects and don’t want to neglect one field for the other. Similarly, they hope for the same convergence to take place between the small-scale work and larger projects. ■

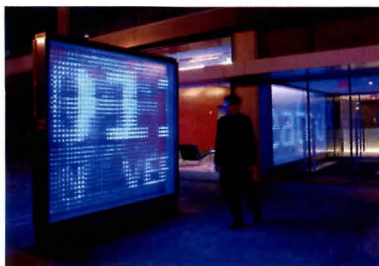

In Washington, D.C., the architects created *Lo Rez Hi Fi*, a light-and-sound installation for a private developer.



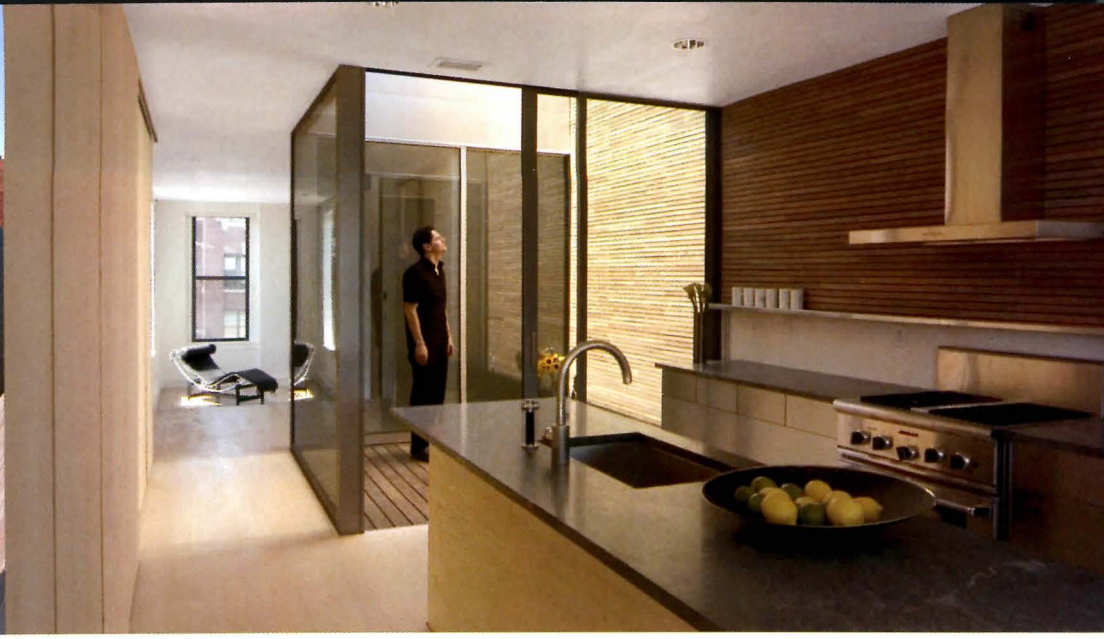

### Outside-In Loft, Boston

A family in Boston wanted to merge two 1,100-square-foot lofts on top of a 6-story building for work-live space. They asked for the space to be divided up into rooms and zones of activity rather than given over totally to an open plan. To bring daylight to the interior, Höweler and Yoon inserted an 8-by-8-foot outdoor courtyard into the heart of the loft. They created two more light wells by placing skylights over a bathtub and shower, and enclosed them with translucent, acid-etched glass walls.







### LOOP Chair Prototype

In 2006, the firm was a finalist for a public-space design, LOOP, for the annual Young Architects competition held by the Museum of Modern Art and P.S. 1 Contemporary Art Center in New York. While it didn't win, LOOP lives on as a chair prototype. Made of recyclable polypropylene, 4-by-8-foot sheets that are heat-formed over wood molds, the single undulating planes are plastic-welded to form a closed loop. The Aalto-gone-wild translucent chair also has enough ductility to feel like a rocking chair.

### White Noise/White Light, Athens, Greece

In 2004, Höweler + Yoon's interactive sound-and-light installation, commissioned for the Athens Olympics, was on display during the games. Located below the Acropolis, the piece was formed of a field of semiflexible fiber-optic strands and speakers arranged on a grid. Infrared sensors and microprocessors embedded within the stalks caused the piece to emit both white light from LEDs and white noise (which contains every frequency in the range of hearing) as visitors entered the field. When they left, light and sound decreased, creating flickering waves of white light and white noise.

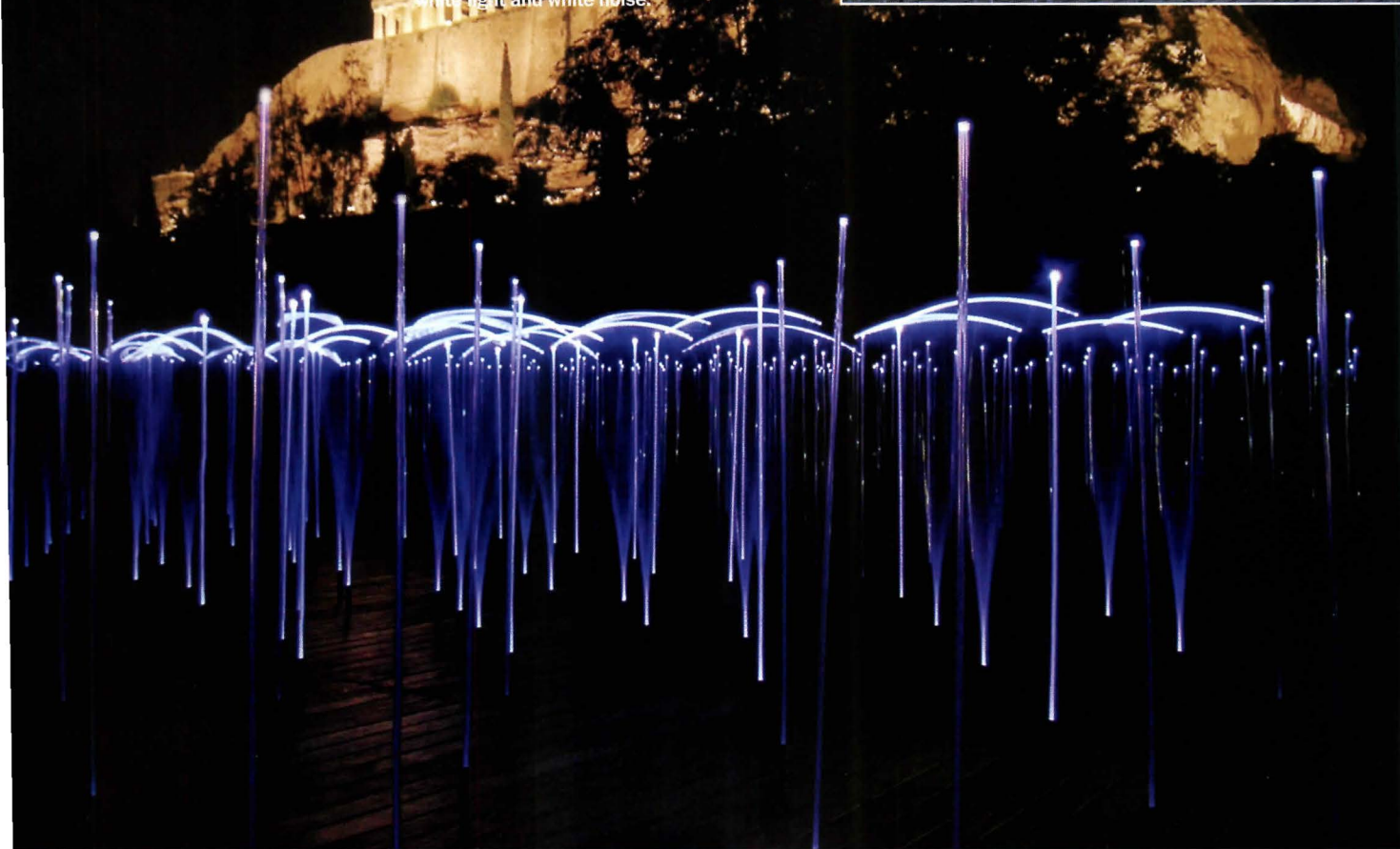



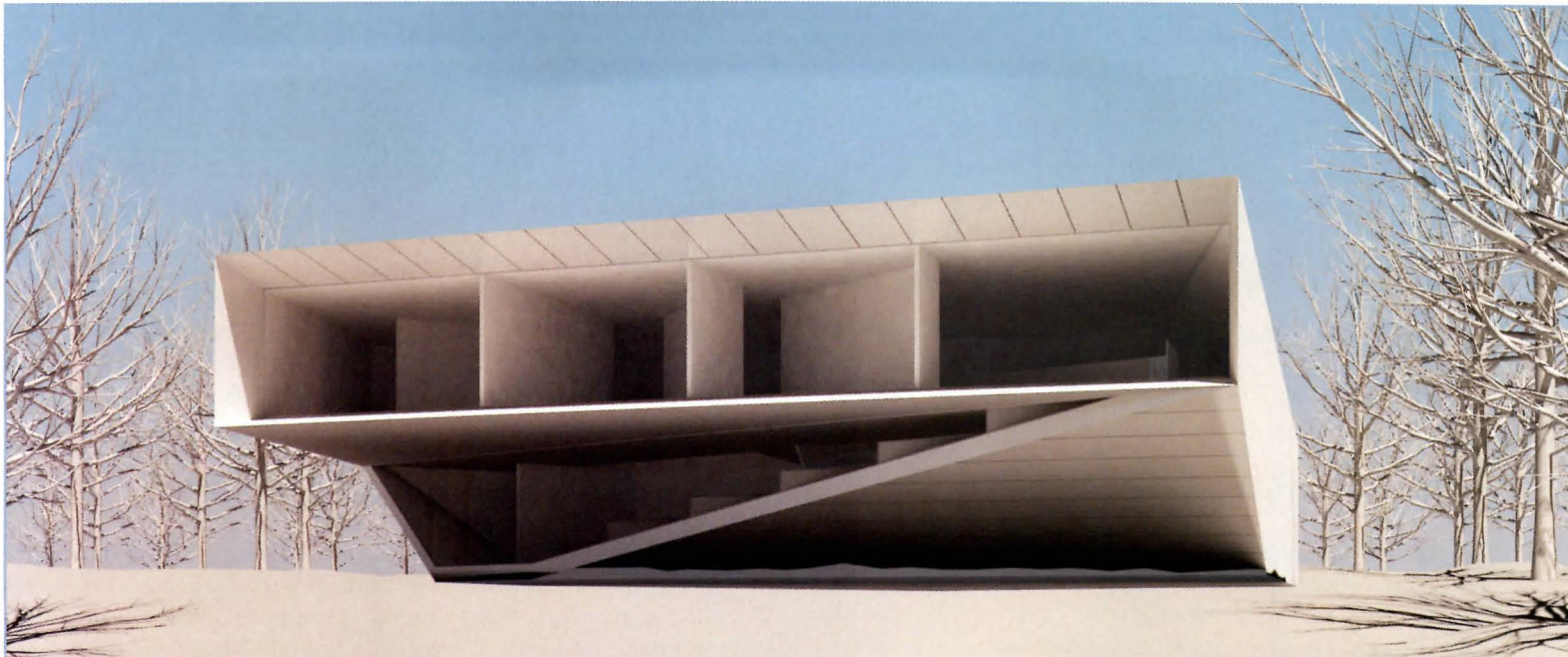

### Triple House, McLean, Virginia

In the Triple House in McLean, Virginia, Höweler and Yoon designed a residence for a couple who needed a place to accommodate visiting grown children. Zinc-clad on a steel-and-timber frame, the house, originally nicknamed the “rhomboid” house, was changed to a plan where a three-car garage on the lower level would connect directly by stairs to bedrooms above. Public living spaces (left) on the ground level are double-height. (The design is currently being constructed according to a simpler solution.)

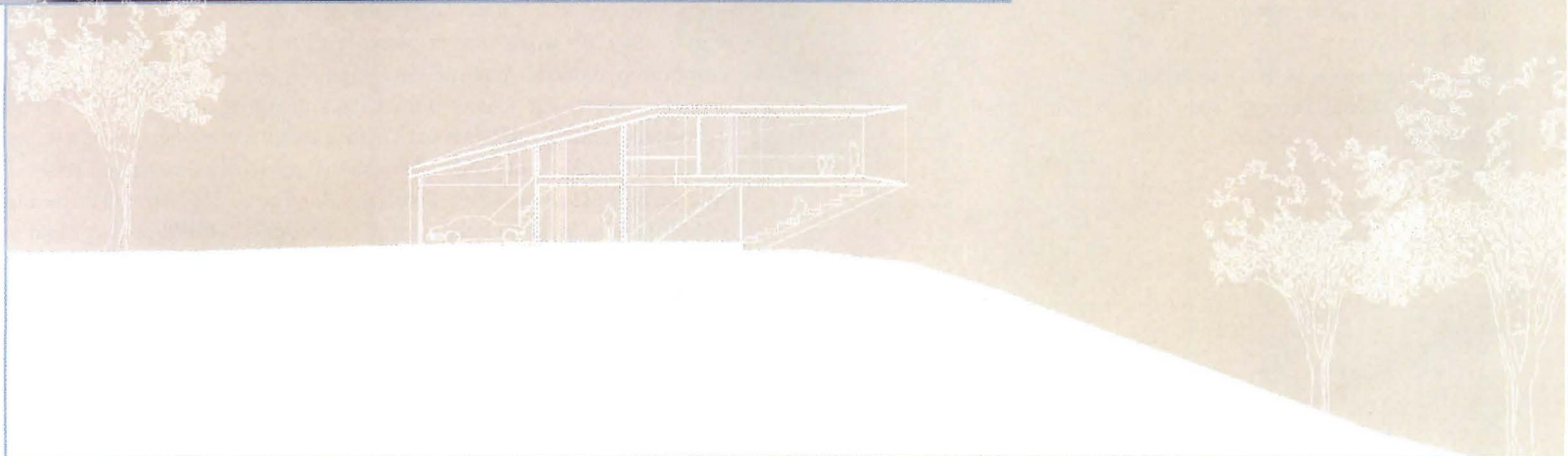





## Moongyu Choi+GaA Architects stacks the deck with multi-layered designs

By Clifford A. Pearson

**Architect:** Moongyu Choi+GaA Architects

**Location:** Seoul, Korea

**Founded:** 1999

**Design staff:** 10

**Partners:** Moongyu Choi, Inchul Kang, Taekwon Yun

**Education:** Choi: Columbia University, M.Arch, 1991; Yonsei University, M.E., 1988; Yonsei University, B.E., 1984; Kang: Kyonggi University, B.E., 1997; Yun: Kyonggi University, M.Arch., 1997, Kwan-Dong University, B.E., 1995

**Work history:** Choi: Hanul Architecture, 1992–99; Toyo Ito Architects, 1991–92; Kang: GaA Architects, 1999–present; Yun: Group One Architecture, 2000–2001; Hanul Architecture, 1997–2000

**Key completed projects:** Opo Wald Haus, Opo, Korea, 2006; J Project 11, Korea, 2005; Y House, Seoul, 2005; K Gallery, Gyeonggi, Korea, 2005; Gilbut Children Publishing, Gyeonggi, 2005; Taehaksa, Paju, Korea, 2004; Booksea Publishing, Paju, 2004; Ssamzie Art Warehouse, Paju, 2004; Ssamziegil, Seoul, 2004; Korea Reading Guidance, Gyeonggi, 2003; I Like Dalki, Gyeonggi, 2002; Booksea Publishing, Paju, 2002; Sungbukdong House, Seoul, 2002; HanSook Cheong Memorial, Gyeonggi, 2002; Daeshin Publishing, Gyeonggi, 2002; Martine Sitbon Shop, Seoul, 2002; Gyangjingu Venture Business Supporting Center, Seoul, 2001

**Key current projects:** H House, Seoul, 2008; Opo Housing, Gyeonggi, 2008

**Web site:** [www.gaa-arch.com](http://www.gaa-arch.com)

Architecture here must be strong," says Moongyu Choi, the founder and principal of Moonyu Choi+GaA architects in Seoul, "because Korea has a difficult climate, with both cold and hot weather." No wonder concrete buildings dominate the cityscapes, and a muscular approach to space and form drives design. The people, too, pride themselves on their direct, forceful nature and love of fiery food. Delicate structures made of glass or lightweight materials just don't work well in Korea, says Choi. His own work combines a sculptor's feel for the bold gesture with a Minimalist's appreciation of planar surfaces. By contrasting heavy materials with transparent ones, solid elements with open ones, he has created buildings that are strong but not overbearing, memorable without being flashy.

Choi joins an impressive group of previous Design Vanguard architects from Korea—Byoungsoo Cho [RECORD, December 2004, page 140], Hailim Suh and Junsung Kim of Architecture studio himma [RECORD, December 2005, page 90], and Yoon Gyoo Jang and Chang Hoon Shin of UnSangDong Architects [RECORD, December 2006, page 74]. "We're friends and we stimulate each other," says Choi. "We share a common material sensibility, because we all work with concrete." Like many in this group, he studied abroad, in his case at Columbia University, in addition to earning his undergraduate degree in Korea. He also worked abroad—for Kohn Pedersen Fox and Steven Holl in New York, and Toyo Ito in Tokyo. Ito, in particular, left a strong impression on him. "I learned from him that architecture is about people and the way they live, not just space and form. He taught me to look at society."

When he started Moongyu Choi+GaA Architects in 1999, the Korean economy was in a recession and jobs were scarce for architects. He entered a lot of competitions and won some. But "in Korea, you may win a competition but lose control of the project, because you don't get to supervise construction," explains Choi. His career turned around when he started working at Paju Book City, a development about 40 minutes outside Seoul where a large number of publishers have moved their operations. Clients in Paju City have hired talented architects from Korea and abroad (including Yung Ho Chang from Beijing, Foreign Office Architects from London, and Waro Kishi from Kyoto) and welcomed innovative design. Choi has completed six buildings at Paju now, developing a body of work that explores various ways of stacking space, combining materials, and punching openings in concrete.

Just north of Paju Book City, a group of artists and art lovers have been building the Heyri Art Valley, a community of galleries, studios, restaurants, cafés, and residences designed mostly by emerging firms like himma and SHoP [RECORD, February 2005, page 116]. In collaboration with Minsuk Cho and James Slade, Choi designed a building dedicated to a popular Korean children's character, creating a slightly surreal environment that blurs such dichotomies as real and imaginary, play and education, culture and commerce. Although colorful and engaging, the building never resorts to kitsch or cliché. Spatially, it's quite sophisticated, moving visitors through a fluid sequence of indoor and outdoor rooms. Like the best of Choi's work, it operates on many levels simultaneously: physical, cultural, social, spatial, and experiential. ■





## I Like Dalki, Gyeonggi, Korea

Choi collaborated with Minsuk Cho and James Slade on this theme-park-in-a-building for the popular cartoon character Dalki. An artificial landscape that starts with a covered garden at grade and ends with a green roof terrace, the building challenges standard notions of indoors and out, real and fantasy. It includes exhibitions and areas for shopping, eating, and playing.







**Taehaksa Publishing,  
Paju Book City, Paju**

This 14,000-square-foot building features flexible space inside to accommodate future changes. On the outside, Choi created an irregular fenestration pattern, with 66 openings that are 6½ feet square and specified a variety of glazing—transparent, reflective, translucent, and colored.



**Booksea Publishing,  
Paju Book City, Paju**

On this project, Choi explored the nature of vertical planes, designing a four-story concrete wall that works as both a filter between the two halves of the lower two floors and as the building's main structural element. Punching large circular openings in the wall and contrasting the concrete with bands of glass add to the visual drama.





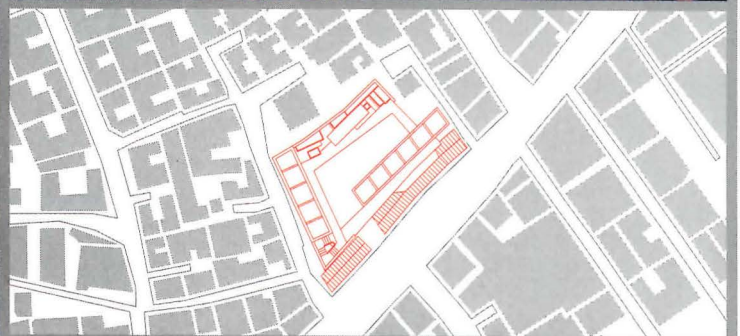

## Ssamziegil, Seoul

Set in Insa-dong, one of the few pedestrian-friendly areas left in Seoul, this shopping center engages the surrounding urban fabric. Choi thought of the project as a “vertical extension of the street,” connecting with neighboring streets at five points and bringing shoppers into a handsome central courtyard.

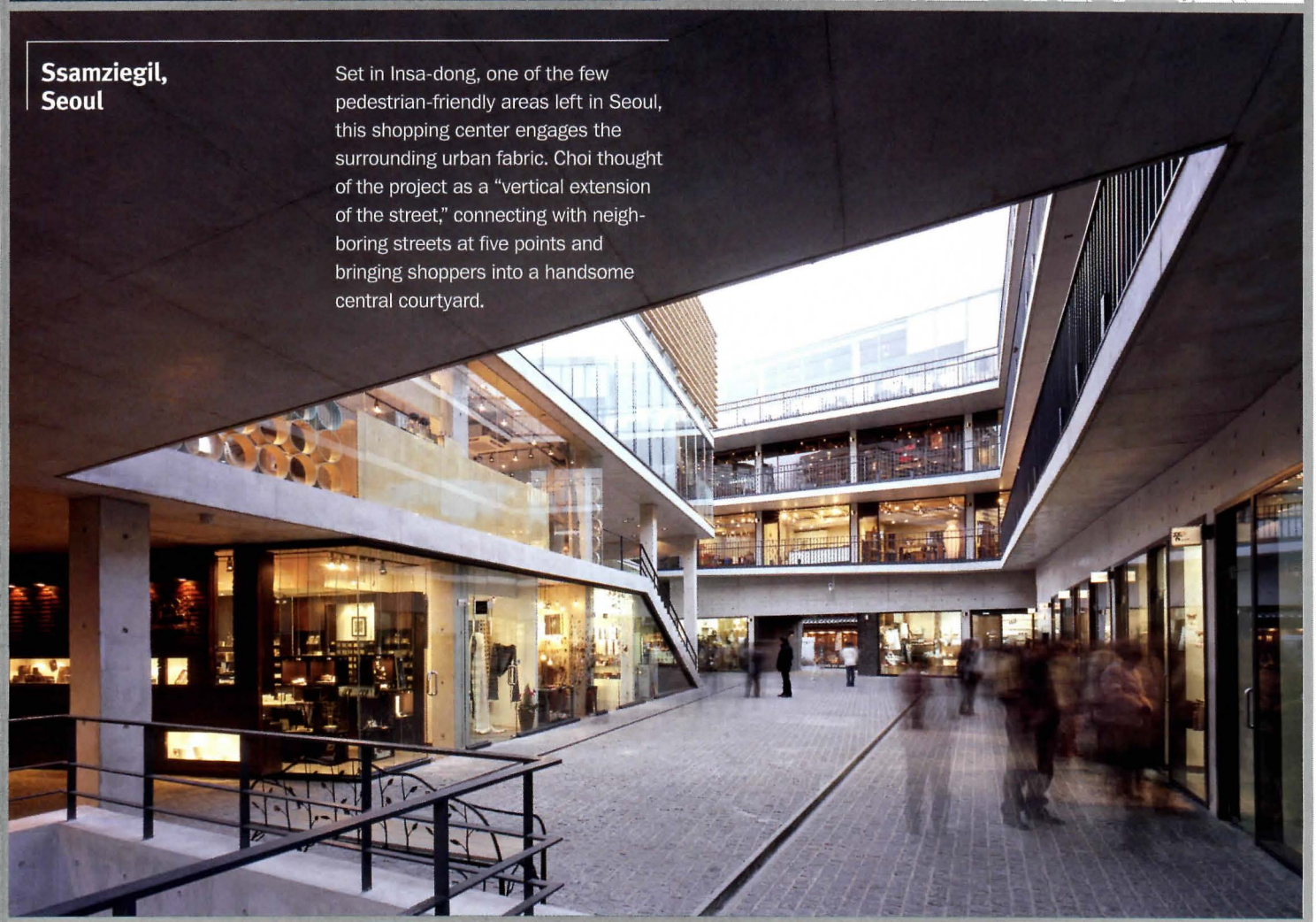



**Hansook Cheong  
Memorial, Paju**

A 5,000-square-foot building dedi-  
cated to novelist Hansook Cheong,  
this project works as a “nature reflec-  
tor,” says Choi. It’s also an elegant  
exercise in stacking complementary  
materials—from the sturdy concrete  
base that houses a conference hall  
to a clear-glass meditative space  
and tearoom on the second floor to  
a mirrored-glass apartment on top.





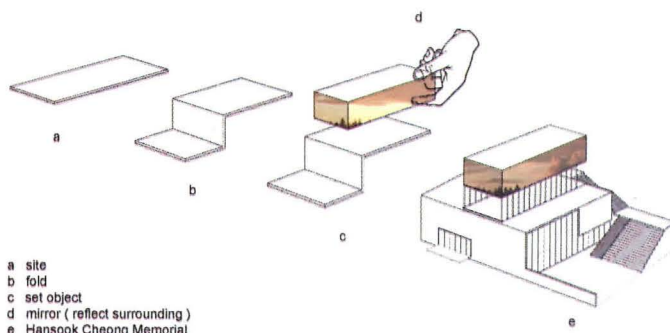

**Arumdri Media,  
Paju Book City, Paju**

For a children's book publisher that wanted the option of renting some of its space, the architect designed a building with floors that slide out in different directions and are wrapped inside with different materials. The scheme gives each floor its own outdoor terrace and identity and continues Choi's experimental approach to stacking.

**C Publisher's Building,  
Paju Book City, Paju**

When this book-storage-and-office building was designed in 2003, there were few buildings in Paju Book City. But a local ordinance called for a different paving material on each of its four sides. So Choi decided to play with the notion of contextualism and skin each side with a different material, responding to what he calls a microcontext.

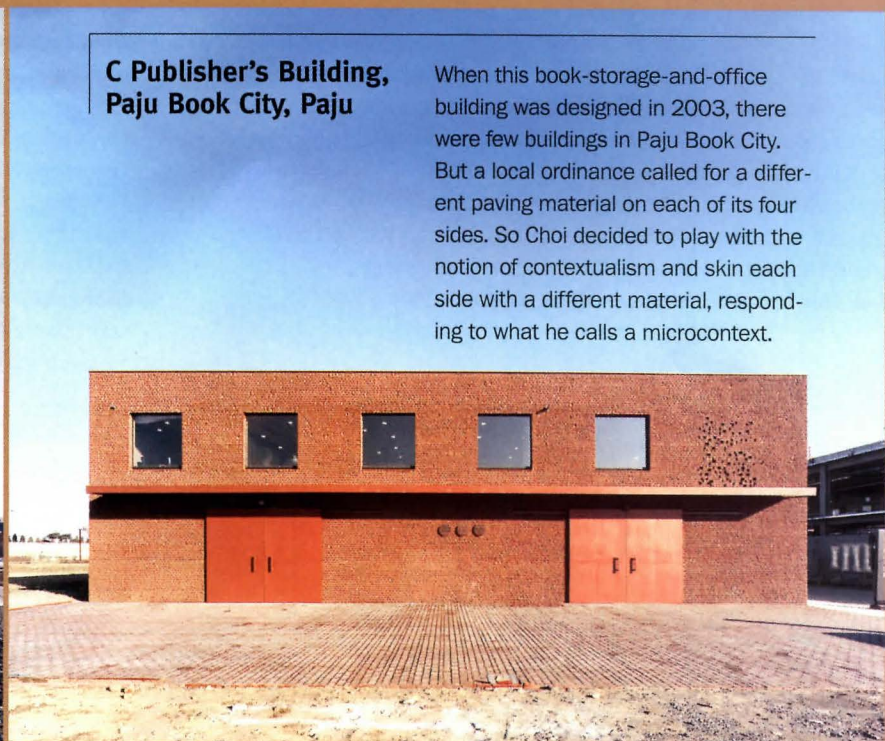





## Tatiana Bilbao, an early urban advocate, seeks an inclusive audience

By Russell Fortmeyer

**Architect:** Tatiana Bilbao/mx.a

**Location:** Mexico City

**Founded:** 2004

**Design staff:** 14

**Principal:** Tatiana Bilbao

**Education:** Universidad Iberoamericana, Mexico City, M.Arch., 1998

**Work history:** Practice—LCM, Romero, Seligson, Bilbao, 1999–2004; Urban Housing and Development Department, Mexico City, Adviser for Urban Projects, 1998–99; Academic—Universidad Iberoamericana, lecturer, 2004–present

**Key completed projects:** Jinhua Architecture Park Exhibition Room, Jinhua, China, 2007; Observatory House, Roca Blanca, Oaxaca, Mexico, 2007; Metrohousing apartments, Mexico City, 2007; Medellin 9 apartments, Mexico City, 2006; H119 apartments, Mexico City, 2005

**Key current projects:** School of Art, Music, and Dance at Educare, Guadalajara, 2008; Kurimanzutto Gallery, Mexico City, 2008; Funeral House, San Luis Potosi, 2008; Mexican pavilion, Zaragoza, Spain, 2008; Botanical Garden, Culiacan Sinaloa, 2008; Housing and Cultural Center, Guadalajara, 2009; Houses in Los Cabos, Baja California Sur, Mexico, 2009

**Web site:** [www.mxa.com.mx](http://www.mxa.com.mx)

Architect Tatiana Bilbao will be the first to tell you her projects don't address the urban problems of her native Mexico City. With a population of nearly 20 million, the interrelated issues of housing, transportation, and, perhaps most important, water infrastructure pose significant challenges. "Our generation is getting a lot of opportunity to build large-scale projects with people who are interested in architecture," Bilbao says, "but we are not working with the government on anything."

Bilbao studied the urban realm early in her career when she conducted research for Mexico City's Urban Housing and Development Department. "In Mexico, the production of space is mostly by the people; there is no planning at all," Bilbao says. By 1999, she had grown frustrated with her inability to accomplish anything but research and struck out to form an architecture firm, LCM, with a friend returning from practicing in the Netherlands. Then, in 2004, she formed her own practice, Tatiana Bilbao/mx.a, and with three other architects, set up a separate collaborative urban research studio to continue her interests in urbanism.

Her most widely published project—an exhibition pavilion completed in 2007 for the Jinhua Architecture Park in China—reflects Bilbao's main interests. She has embedded the pavilion into the landscape, designing a circuitous route through its multilevel spaces and strategically blocking and uncovering views along the way to its interior gallery. "I could understand a lot of things from going into a Chinese garden," Bilbao says. "What I loved is the way you discover it, where you can't understand the whole of it without going through the entire project."

The Jinhua project's attributes—its topographical plan and triangulated spatial organization, raw concrete and stone finishes, and its embrace of the architectural promenade—appear in Bilbao's recent designs, most of which operate on larger scales. A master plan for a botanical garden in Culiacan Sinaloa, Mexico, applies her circulation theories to a sprawling site, while a mixed-use residential, commercial, and arts center in an old factory in Guadalajara reimagines industrial production in cultural terms. Elevating the public's appreciation of the natural and built environment is one of the architect's chief concerns.

Bilbao accepts that her project portfolio is varied, and she quietly complains that she can't retest her theories on building types because each new commission is so different. Currently, she's at work on the Mexican government's pavilion for a 2008 expo in Spain that will focus

on water conservation. But she's also designing a funeral parlor. One of her earliest projects, a beach house for the artist Gabriel Orozco's family, still makes her laugh. The house, which has a round pool on the roof, was organized around the conceit of camping. Like a tent, you must exit each room to the exterior in order to get to another room, such as the toilet or kitchen. "For Gabriel, it was not architecture; it's more of a living sculpture," Bilbao says, noting that she collaborated with Orozco on realizing the artist's initial design. "Architecture has to be functional. After it was built, and I understood how it worked like a tent, I thought it was really clever." ■



Gabriel Orozco's Observatory House.



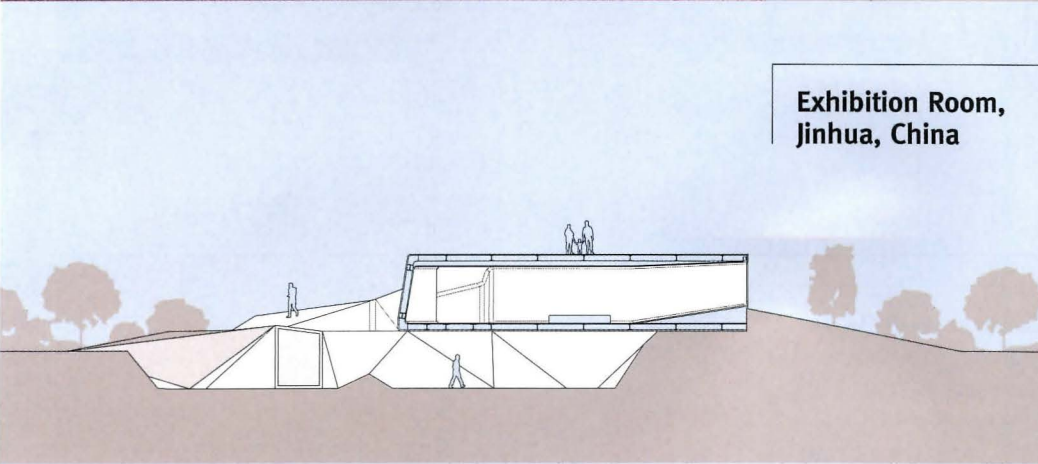

### Exhibition Room, Jinhua, China

The Jinhua Architecture Park in China was an invited commission for 16 architects from around the world. Bilbao, who won the gallery commission from a lottery system, thought of the pavilion as a Chinese garden. Visitors need to fully walk the pavilion's ramps and interior and exterior spaces before understanding how the otherwise simple building functions. The architect deliberately simplified the interior to allow for a variety of installations and performances.





### Medellin 9, Roma, Mexico City

For this apartment building, Bilbao played with mixing the organization of units on multiple floors and expressing that on the exterior concrete screen wall. Bilbao says she likes to work with concrete because of its purity as a material. "The space is complicated enough so there's no need to have more colors and materials," she says.

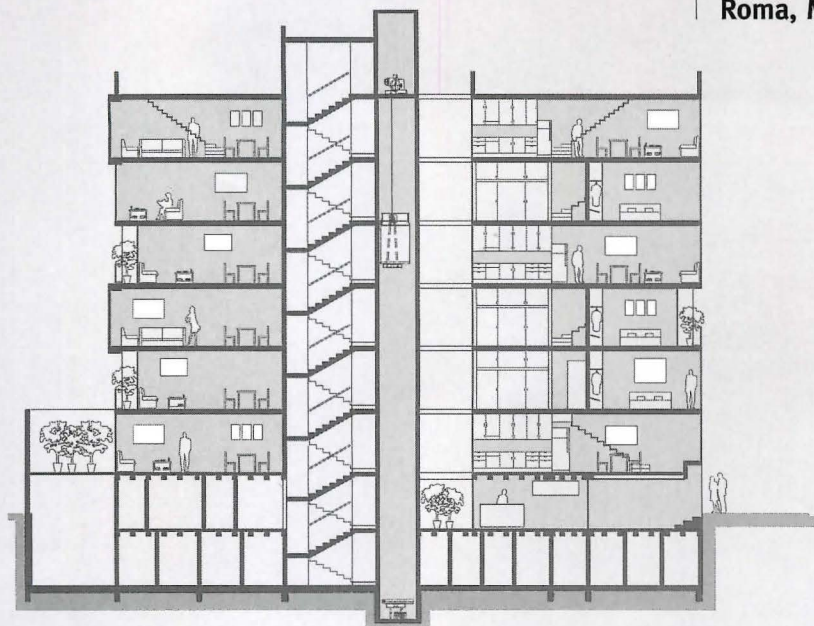

### Housing and Cultural Center, Guadalajara, Mexico

Bilbao envisioned this mixed-use residential, commercial, and arts center in an old factory site as a production line of culture for the neighborhood. By linearly threading public space through the complex, the architect ensures the public can access the cultural offerings. The project also incorporates wind turbines and photovoltaics, in addition to efficient natural gas generators, to offset 60 percent of its energy needs.

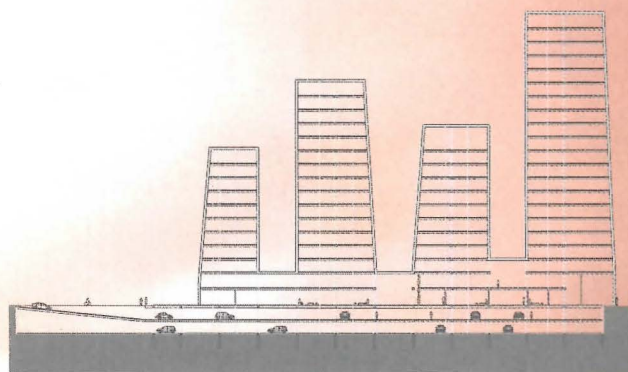





### **Botanical Garden, Culiacan Sinaloa, Mexico**

Among Bilbao's largest projects, this master plan for an existing botanical garden incorporates a variety of facilities, such as an auditorium, restaurant, and gallery. She is also working with 30 artists, including Gabriel Orozco, James Turrell, and Dan Graham, to provide installations throughout. Although her younger staff prefer the computer for design, Bilbao develops models and sketches for all of her projects. "If I'm not yet into the project, I have to look at the models and then sketch," she says.

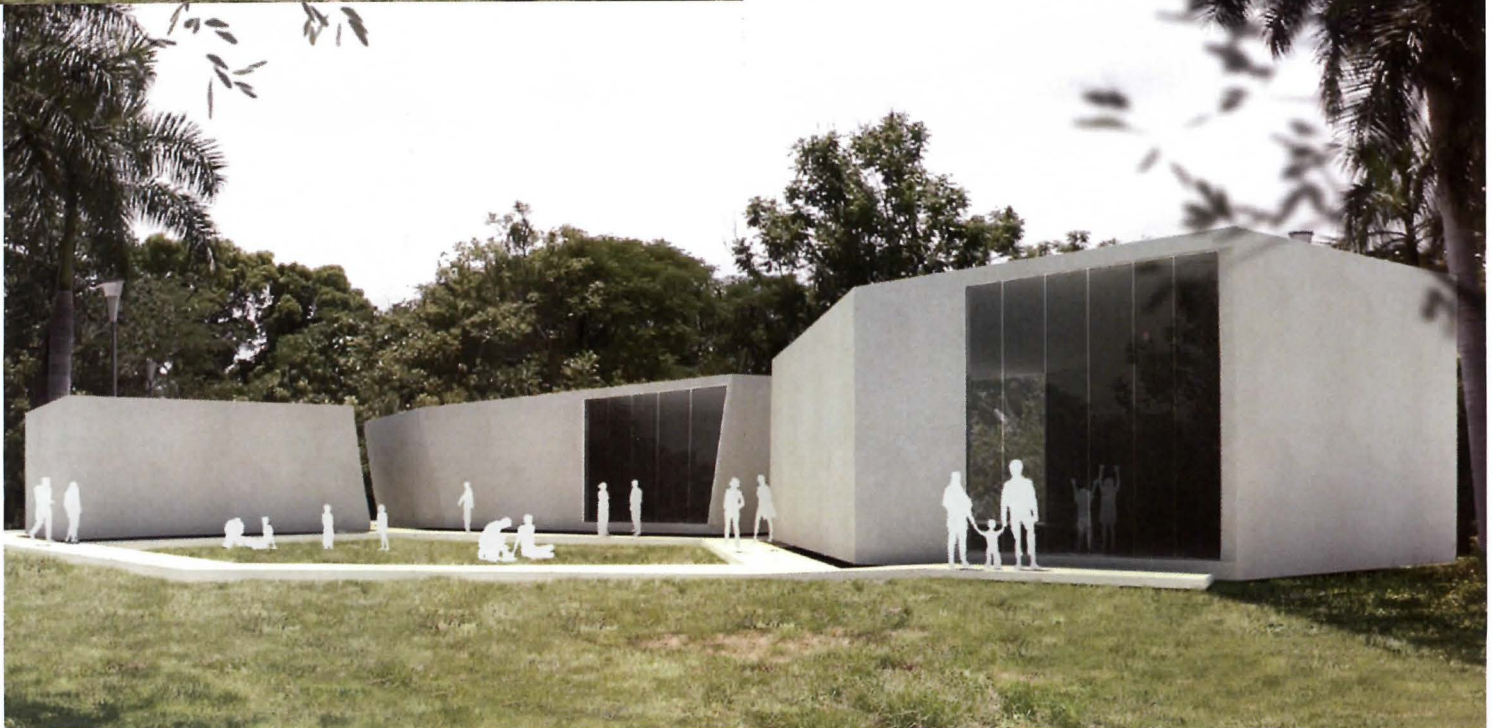



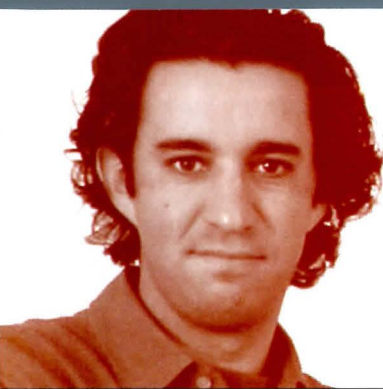

## Sebastian Mariscal mixes design with business and social responsibility

By David Sokol

**Firm:** Sebastian Mariscal Studio

**Location:** San Diego

**Founded:** 2000

**Design staff:** 7

**Principal:** Sebastian Mariscal

**Education:** Self-educated

**Work history:** Sebastian Mariscal Studio (founder), 2000–present; Jonathan Segal, FAIA, 1997–2001; Tonet Sunyer Arquitecto, 1995–96; Alberto Kalach Taller de Arquitectura X, 1992; Mariscal Taller de Arquitectura (founder), 1988–95; Raul Octavio Mariscal, 1984–88

**Key completed projects:** Tercio Winery, Valle de Guadalupe, Mexico, 2007; SIX, La Jolla, California, 2007; 2inns, La Jolla, 2007; On Grape, San Diego, 2006; Valle House, Valle de Guadalupe, 2004; Billboard Lofts, San Diego, 2003; State+Date, San Diego, 2002

**Key current projects:** Pazo de Laja Hotel, Valle de Guadalupe, 2008; Krishnamurti Center, Tijuana, Mexico, 2008; Codet Vision Center, Chula Vista, California, 2008; Casa Chayet, La Jolla 2008; Casa MTY, Monterrey, Mexico, 2008

**Web site:**

[www.sebastianmariscal.com](http://www.sebastianmariscal.com)

Sebastian Mariscal found his professors not in the halls of academe, but in the offices of practicing architects. Starting when he was 14, he spent afternoons and evenings after school working for his father, Raul Octavio Mariscal, a public-housing architect in Mexico City. “It was a very intense education,” Mariscal says, “and it influenced my perspective that architecture has a social responsibility.” Eschewing a formal architectural education, four years into his apprenticeship with his father, he opened his own design firm. He remodeled some interiors, then designed buildings in Mexico ranging from houses to a television studio.

He closed his Mexico City firm in 1995 to work for architect Tonet Sunyer in Barcelona, then moved to San Diego to join Jonathan Segal, FAIA, and learn about Segal’s business combining architecture and real estate development. In 2000, Mariscal went out on his own again with State+Date, a two-family residence he built with an investor partner. By designing and managing the project efficiently—confining all plumbing to one wall, for example, and ordering all precut parts—he minimized on-site labor. And by deftly organizing his construction crew, he finished the building in four months. Today, his firm handles architectural commissions and his own development projects; another arm of the business does general contracting.

While Mariscal owes an obvious debt to Segal, he also borrows from his two other mentors. Calling his previous employment stints “ingredients” in his technique, Mariscal notes, “The more we can add to our design process, the less subjective architecture can be and the more transcendental the building can become for the user and the city.” Like his father, Mariscal focuses on residential buildings, mostly located on challenging urban sites. “I don’t believe in suburbia,” he says. “I believe in eliminating the use of cars and increasing the intensity of the city experience.” The lower market value of difficult sites “also cuts my purchase price, while posing the challenge of making a good piece of architecture.”

Mariscal designed the two-family building On Grape on just such a site, devising a pair of units each measuring 36-by-68 feet. To buffer occupants from the busy street corner, he developed a ventilated facade made of engineered stone and Cor-Ten steel clipped to the building’s wood framing, creating a heat- and noise-protecting pocket of air. Then he connected the units’ front and rear volumes with bridges traversing an internal, bamboo-filled courtyard. In addition to offering a glimpse of nature in downtown San Diego, the plan obliges residents to end their day with a pleasant ritual: crossing the bridge and retiring to the bedroom.

On Grape also underscores Mariscal’s interest in merging indoors and out, which he picked up from Sunyer and finds well suited to the temperate climate of both Mediterranean Spain and Southern California. At 2inns, Mariscal surrounded the main living area with a perimeter of glass doors that can fold away, exposing guests to the elements and views of the Pacific Ocean. And for the Tercio Winery in Mexico’s Baja peninsula, he created just a shell that remains open on one side. Moving back and forth between the U.S. and Mexico, between designing and building, Mariscal remains open, too—to ideas from different places and disciplines. ■

David Sokol is a freelance writer and frequent contributor to RECORD.



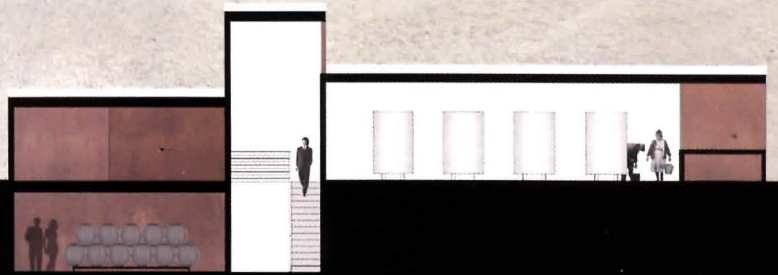
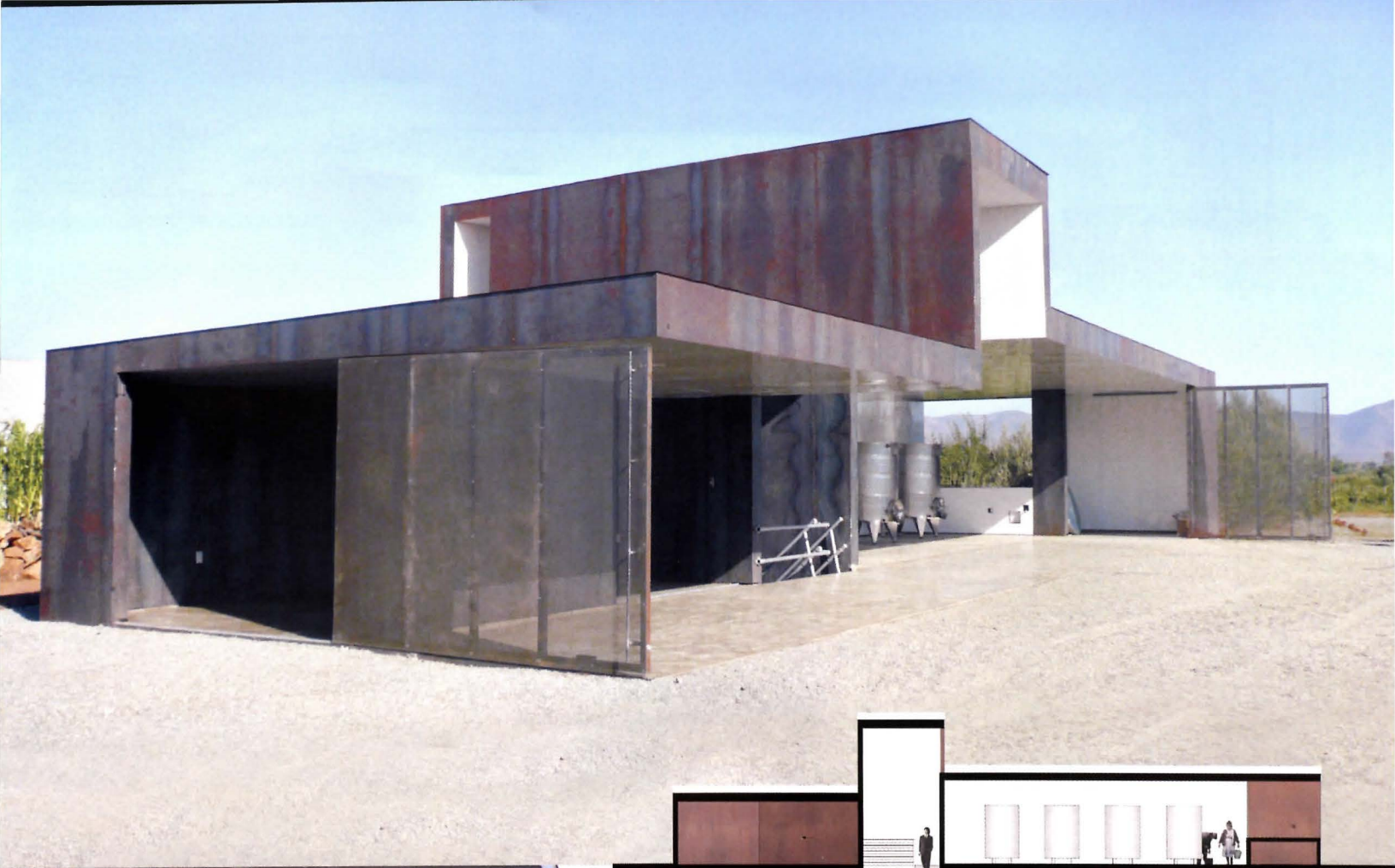

**Tercio Winery,  
Valle de Guadalupe,  
Mexico**

This recently completed shelter for winemaking equipment expands the campus of the 2004 Valle House. The buildings stand perpendicular to one another, opening to a common courtyard that injects a dose of urbanism into the rural landscape. Mariscal imagined Tercio as a layer of the Baja landscape: Its three Cor-Ten-steel-clad volumes resemble nearby mountains and provide deep overhangs for the open interior, which is finished in white acrylic.







**2inns,  
La Jolla, California**

Mariscal lives in one of the two units in this year-old building, just a few blocks from the Pacific Ocean. Thanks to the hillside site, he did not have to design a tall building to capture water views. Instead, he placed a kitchen-anchored common space above a half-level plinth and ringed it with doors that fold away. A more opaque, ipé-clad bedroom sits atop the steel-framed room-cum-patio.



**Six,  
La Jolla, California**

This Mariscal-developed building in La Jolla comprises six town-houselike units. Front patios create a small protective zone between ground-floor living areas and the street, although full-height sliding glass doors in the front and rear also provide the option of transforming the space into a seamless outdoor experience.







**Valle House,  
Valle de Guadalupe,  
Mexico**

Set amid the vineyards and scrub landscape of Valle de Guadalupe, Mexico, this weekend house appears like a pavilion in a garden. A 177-foot-long stone wall, almost 10 feet high, runs parallel to an entry road and allée of olive trees. The wall serves as the main axis for the house, which is punctuated by habitable volumes and voids. An equally grand, winglike canopy dominates one side of the building.







**On Grape,  
San Diego**

Just 18 feet wide and 68 feet long, On Grape presented Mariscal with the dual challenges of constructing a substantial building on an infill site and shielding the two-family property from a busy street corner. Each unit runs the entire length of the lot, while a ventilated facade of Cor-Ten steel and engineered stone insulates occupants from noise and sun.



**State+Date,  
San Diego**

Mariscal's first project in San Diego, the two-family State+Date makes the most of its 1,550-square-foot lot, with volumes clad in materials such as redwood and stainless steel to create a cityscape in miniature. The alignment of load-bearing walls, the absence of interior partitions, the absence of interior partitions, and the restriction of plumbing to a single wall made the project fast to build.



PHOTOGRAPHY: © ROBERTO ZEBALLOS (TOP TWO)



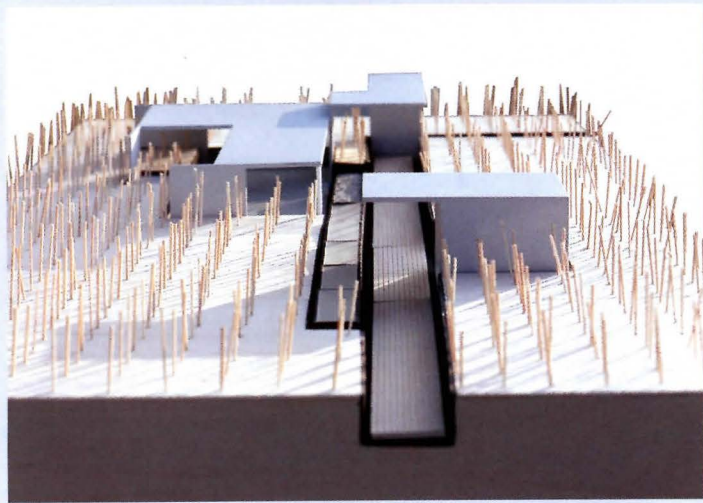

**Pazo de Laja Hotel,  
Valle de Guadalupe,  
Mexico**

Mariscal disperses eight rooms among three buildings in this forthcoming hotel addition to the well-known Laja Restaurant. A wine pavilion sits slightly below grade, encircled by grapevines, while the orchard offers an intimate look at food production on-site, and the copper-clad tower includes two suites commanding views of the distant mountains.





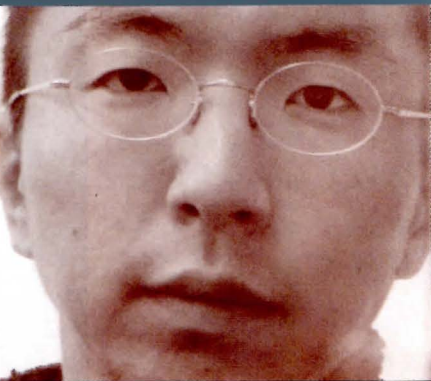

## Sou Fujimoto fractures plans and sections while bringing together people

By Naomi R. Pollock, AIA

**Architect:** Sou Fujimoto Architects  
**Location:** Tokyo  
**Founded:** 2000  
**Design staff:** 8  
**Principal:** Sou Fujimoto  
**Education:** University of Tokyo, B.A., 1994  
**Work history:** Sou Fujimoto Architects, 2000–present  
**Key completed projects:** House O, Chiba, 2007; Treatment Center for Mentally Disturbed Children, Hokkaido, 2006; 7/2 House, Hokkaido, 2006; Diagonal Walls, Hokkaido, 2006; T House, Gunma, 2005; Dormitory for the Mentally Disabled, Hokkaido, 2003  
**Key current projects:** House N Oita, 2008; Wooden lodge in Kumamoto, 2008; Tokyo Apartment Tokyo, 2008; House HA, Tokyo, 2008; House OM, Yokohama, 2008; Utsunomiya project, Tochigi, 2008; Library and Art Museum of Musashino Art University, Tokyo, 2010  
**Web site:** www.sou-fujimoto.com

Like young architects everywhere, Japanese designers often get their first job from a family member or friend. Rarely, though, does the assignment involve a mental hospital in the middle of a remote, northern island buffeted by Siberian winds. But Sou Fujimoto's psychiatrist father runs a residential facility on Hokkaido. And when the hospital needed an additional building, the doctor turned to his 20-something son, even though the ink on his undergraduate diploma from Tokyo University was barely dry. Earmarked for occupational therapy, the 1,938-square-foot building was realized with the aid of a local architect.

After this debut, Fujimoto hit a five-year dry spell. But instead of closing up shop, going to graduate school, or joining an established firm, he bided his time with competitions and conceptual explorations. "My goal was to create a completely different way to design architecture," he explains. Forsaking standard columns, slabs, and stairs, he envisioned a single, multipurpose element that could play all three roles. This idea coalesced in Primitive Future House, a theoretical project made entirely of stacked slabs that can serve as structure, stairs, fenestration, even furniture.

Now Fujimoto is getting the chance to test this radical approach by designing Atelier/House in Hokkaido for his artist brother. Instead of conventional floors, it consists of five, vertically stacked layers of space used in various combinations to delineate human-scaled, functional areas. Though staggered in section, the project is essentially one room that contains places of different heights and character, explains Fujimoto. Straddling the line between nature and artifice, Atelier/House was not tailored exclusively to the client's needs. Instead, Fujimoto expects his brother to make accommodations to the house. It is precisely this paradox of integrating accidental places and architecture that motivates Fujimoto.

Such unintentional spaces have already generated positive responses from a discerning group of users—the kids who reside at a 50-bed treatment center for mentally disturbed children in Hokkaido's Date City. Commissioned by one of his father's colleagues, Fujimoto created a building that looks like a haphazard group of boxes bound together with window walls. Inside, it works as a pint-size city composed of free-form plazas and tiny cubic buildings. Though the quirky corners and awkward alcoves between minibuildings might make adults blanch, the kids adore them. "Children always invent new uses for space," explains the architect.

Instead of complying with an overriding order, most of Fujimoto's works are compilations of local relationships between one functional zone and its neighbors. Sculptural and site-specific, each rendition of this idea, be it a house or a hospital, is more concerned with the connection between individual parts than the building form or plan as a whole. At the moment, he is taking this concept to new heights in his design for Tokyo Apartment, a five-unit housing project composed of 13 pitched-roof house forms stacked helter-skelter. Though it looks precarious, this building echoes the organic, urban character of Tokyo, the city that Fujimoto now calls home. "I think the city is both very artificial and very natural," says Fujimoto. "For me, this is a very fresh experience." ■

Naomi R. Pollock is RECORD's Tokyo-based special international correspondent.



For Tokyo Apartment, Fujimoto stacked 13 houselike forms to create five dwelling units.





**Treatment Center for  
Mentally Disturbed  
Children, Hokkaido**

As variegated as a small city and as intimate as an individual house, this 27,300-square-foot Treatment Center for Mentally Disturbed Children was completed in 2006. It consists of 24 small boxes arranged in a seemingly random manner. The two-story cubes contain bedrooms, treatment rooms, staff offices, and other programmatic elements, while the interstitial spaces include dining areas, a multipurpose area, and an array of secluded alcoves and nooks for the children to use freely.

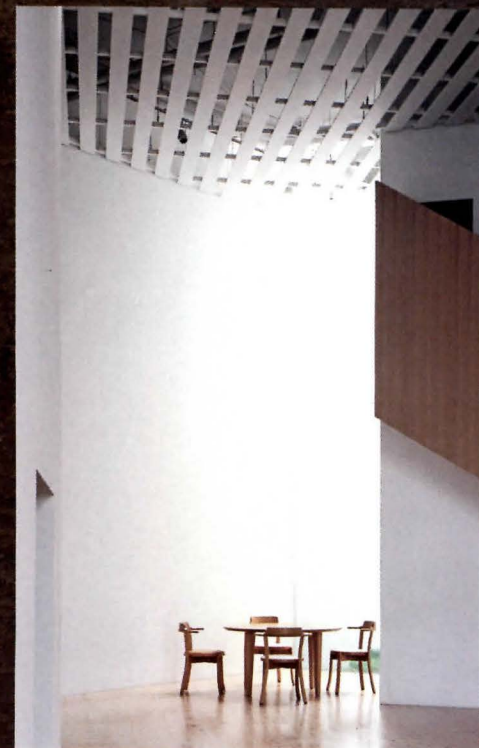



## Dormitory for the Mentally Disabled, Hokkaido

This 6,100-square-foot project serves as a communal home for 20 adults. A chain of 11 cubes—some single- and some two-story—it takes advantage of the natural topography. Touching corner to corner, the boxes contain private bedrooms as well as communal living rooms, dining rooms, and washrooms. Wedge-shaped spaces in between hold the entrance, stairs, and a series of alcoves for residents to use as they please.



## House N, Oita City

Currently under construction on the island of Kyushu, this 1,625-square-foot house features three progressively smaller, rectangular shells nested one inside the other. The outermost box encloses an indoor/outdoor garden (plus an enclosed kitchen and bathroom), while the second holds sleeping quarters and a guest room, and the wood-walled innermost shell houses a combined living and dining room.







## House O, Chiba

A weekend retreat overlooking the Pacific Ocean, this 1,390-square-foot house for a doctor and his family is one continuous room that provides separate functional areas branching off in different directions. While the west side of the house is enclosed with concrete walls to shield the interior from a two-lane highway out front, the east offers full-height glass panes that frame a variety of ocean views.







## Diagonal Walls, Hokkaido

A group home for adults with dementia in Noribetsu City on the island of Hokkaido, this 8,020-square-foot, single-story facility features two housing blocks joined at a shared, free-form space containing the staff areas and entrance. Each block can accommodate 18 patients in its nine bedrooms plus communal living and dining areas. Though the plan is a straight grid, the walls move up and down at their point of intersection, resulting in triangular openings that connect one room to the next.



## Primitive Future House

The conceptual answer to Fujimoto's quest for a new relationship between the human body and architecture, this project represents a prototype for residential design. Instead of conventional columns and floor plates, slabs layered at 14-inch intervals not only hold up the house, but can serve as furniture, fittings, and stairs.

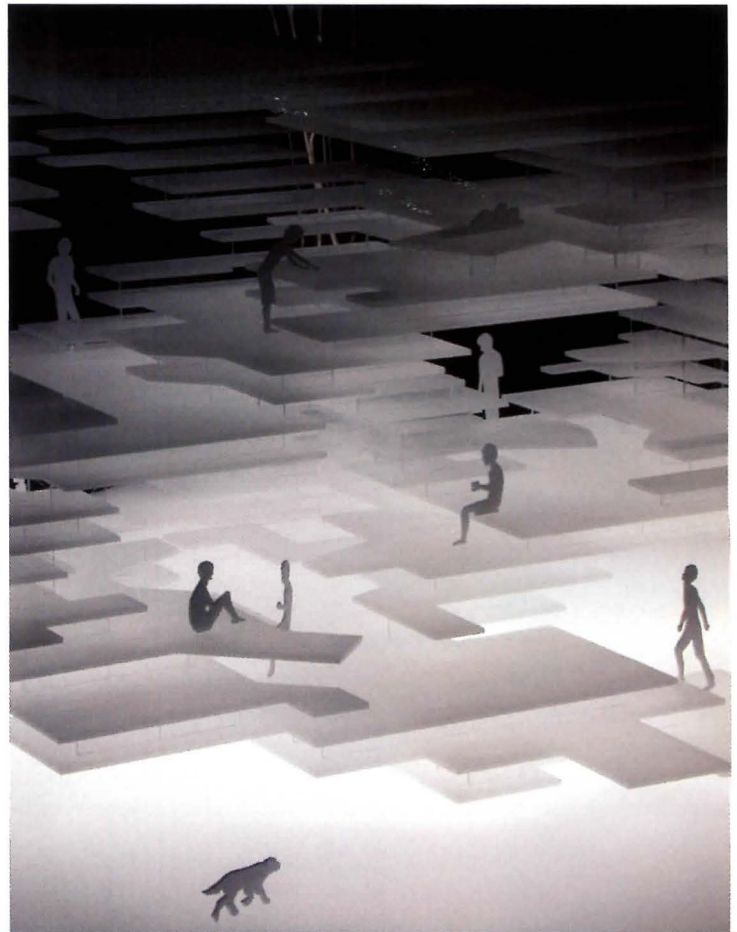
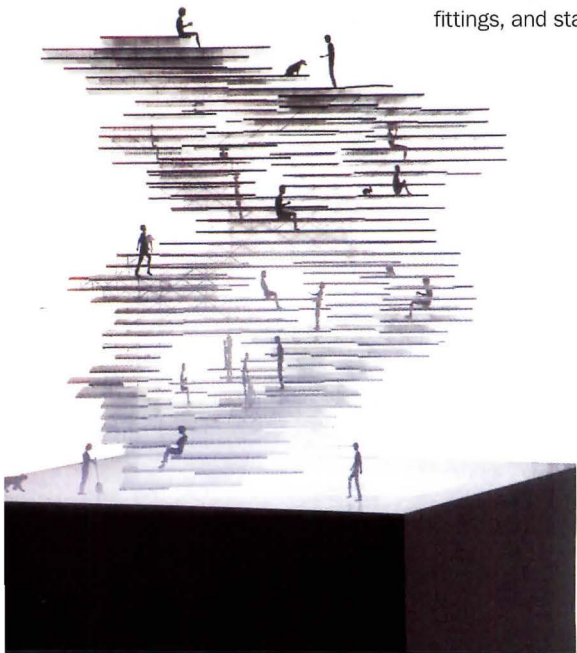



**7/2 House,  
Hokkaido**

Completed in 2006, this 1,100-square-foot project consists of two homes set within seven iconic, pitched-roof house forms. Fujimoto created a disjuncture between inside and out by not always placing interior walls where the roofs seem to indicate they should be. Skylights help illuminate some rooms from above.







## BROISSINarchitects blazes a trail for the next generation of Mexican architects

By Beth Broome

**Architect:** BROISSINarchitects

**Location:** Mexico City, Mexico

**Founded:** 2007

**Design staff:** 8

**Principal:** Gerardo Broissin

**Education:** Anahuac University School of Architecture, Mexico City, B.Arch., 1998

**Work history:** Practice—Grupo BH, 2000–2006; Academic—Anahuac University, 2007–present

**Key completed projects:** Must Nightclub, Mexico City, 2007; Taanah Sak House, Mexico City, 2006; Vladimir Kaspé Cultural Center, Mexico City, 2006 (with Gabriel Covarrubias and Jorge Hernandez); FUA Showroom, Mexico City, 2005

**Key current projects:** Demisi Boks Headquarters, Mexico City, 2007; Kunmeti Houses, Mexico City, 2008; Anahuac Building, Mexico City, 2008; Swimming Lane Loft, Mexico City, 2008; Sua Hotel, Morelos, Mexico, 2010

**Web site:** [www.broissin.com](http://www.broissin.com)

Perusing Gerardo Broissin's portfolio, it's hard to believe the depth and breadth of work the 32-year-old has built in his short career, especially considering he wasn't always sure of what he wanted to do. As a teenager he was torn between pursuing medicine and architecture. "They are both very passionate careers," he notes.

Eventually, architecture won out, and Broissin devoted himself to his studies at Anahuac University in his hometown of Mexico City. But it was at the Southern California Institute of Architecture (SCI-Arc) in Los Angeles, while taking a design course abroad during his final year of school, that he had his moment of clarity. While there, he was exposed to the experimental and transformative potential of architecture—a departure from his studies at the more conservative and rigid Anahuac program. Returning to complete his degree with his newfound vision was a difficult transition, he says.

Shortly after graduating in 1998, Broissin set out on his own, eschewing the traditional apprenticeship route. His first project was a house for his cousin in Mexico City. "A typical commission in Mexico," he says, "where the client arrives with lots of magazines and shows you the house they'd like to have." The result, a white stucco building with a red-tile roof, was "like any house you can find in Mexico," says Broissin apologetically. "It didn't bring anything to architecture, but the client was very happy with it." What the architect describes as a "very common office interior" soon followed. While not exactly "big idea" material, these jobs served as the springboard for Broissin's partnership with Jorge Hernandez and the founding of their firm, Grupo BH in 2000.

Since then, Broissin has had ample opportunity to put some of his ideas to the test and has worked on a variety of retail showrooms, custom residences, a high-concept nightclub, and a prize-winning cultural center for Mexico City's La Salle University. While being mindful of budget constraints and client and end-user needs, Broissin avoids following any established design principle. "The moment you follow one," he says, "you have lost the opportunity to work with fresh ideas." Another way Broissin stays fresh is by entering competitions, including a scheme for the Estonian National Museum, done in collaboration with Federico Soriano's Madrid firm, S&Aa; a modular, multifamily dwelling in Gdansk, Poland; and, most recently, a residential tower for the city of Vancouver, British Columbia. Since the disbanding of Grupo BH earlier this year, Broissin has kept the momentum going as BROISSINarchitects and is currently working on a number of projects, including a private residence overlooking the mountains in San Luis Potosi, Mexico, and a 20-room boutique hotel in Morelos, Mexico, which he will shroud in a woven fiberglass sunscreen to reduce solar heat gain.

To date, all the architect's work has been in Mexico, and while he wouldn't be opposed to taking his practice onto the international stage, he likes staying local. "This is the place of my birth, and I want to bring something new to architecture in my country," says Broissin, who maintains that a tradition of mediocre architecture has taken hold south of the border over the past several decades. For Broissin, working here presents an opportunity: "It's a challenge for my team to break some of these architectural traditions, to do something to inspire new generations of architects in Mexico." ■



The SUA Hotel will have a woven fiberglass sunscreen.





**Vladimir Kaspé  
Cultural Center,  
Mexico City**

This cultural center at La Salle University houses the book collection donated by architect and former La Salle professor Vladimir Kaspé. Broissin collaborated on it with his uncle Gabriel Covarrubias and Jorge Hernandez. A simple steel-and-concrete, channel-like volume sits on steel columns and houses a frosted-glass box. An exterior ramp provides access to a computer lab and services at ground level, and the Kaspé library and an exhibition space on the second floor. A roof garden tops off the building.





## Ole Showroom, Mexico City

Located in the Mexico City's Center for Architecture and Design, this showroom for a lighting consultant takes to heart the client's belief in the power of light to affect perception and sensation. A movable, laminated-glass wall divides the room, isolating office and exhibition spaces. At center stage of the exhibition space is a meeting room, formed by nine white screens that descend from the ceiling and are illuminated by color projected from a light box installed in the floor.



## Urban Shelter, Vancouver

This competition entry offers an alternative to the base-and-shaft building typology that has proliferated in Vancouver (and around the world). These 270-square-foot aluminum pods shelter two people and feature most of the creature comforts of your average home. Solar panels on the roof and in the octagonal windows help power the transportable units, which cling to the sides of a tower.

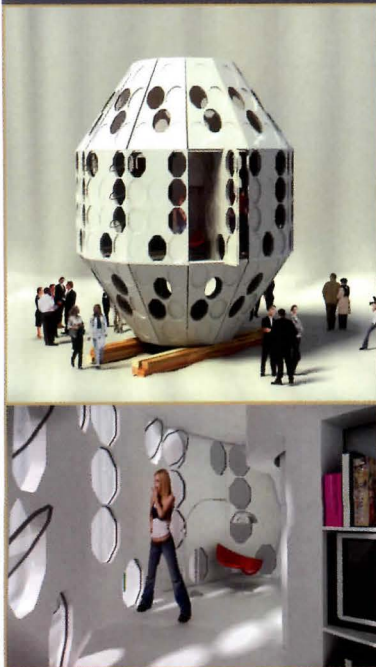





**FUA Showroom,  
Mexico City**

Also located in the Center for Architecture and Design, this prize-winning showroom was made for a company that designs and sells blinds. A single oak-plywood sculptural form bends and folds and is encased within a glass box, itself an object on view. Four movable display cases let the client alter the interior configuration of the space and, with their incandescent fixtures, provide the principal source of illumination.



PHOTOGRAPHY: © VICTOR PALACIO PASTRANA (OPPOSITE, TOP); PAUL CZITROM (THIS PAGE)



**Estonian National  
Museum,  
Tallinn, Estonia**

BROISSINarchitects collaborated with Federico Soriano's Madrid firm, S&Aa, in this competition for an iconic national museum. The approximately 100,000-square-foot building is a kind of ode to the triangle—a form that is repeated throughout, comprising the basic geometry and also the steel framework that forms the skin and interior walls and ceilings.



**Must Nightclub,  
Mexico City**

Designed with nightclub posing in mind, Must offers ample opportunities to see and be seen. A raised glass runway, with images projected on its far wall, and an illuminated stair that feeds into the dance floor below provide platforms for announcing arrivals and attracting glances. Use of mirrors and extensive lighting schemes over the mostly gray interior create illusions of expansiveness and drama.





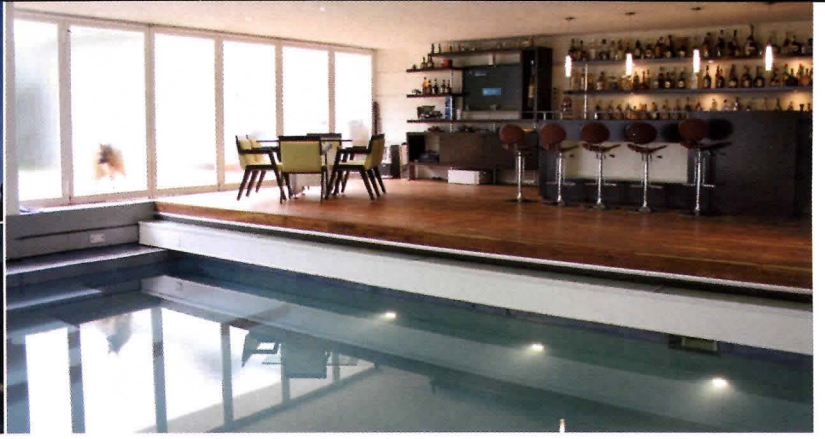

### Taanah Sak House, Mexico City

Taanah Sak (“White House” in Mayan) was designed for a garment industry executive who is also in the business of entertaining. Three levels and a variety of facade textures break the monotony of the 10,750-square-foot house, which faces a garden and reflecting pools. An entire end of the house is glazed (below), functioning as a big light shaft that brings illumination to the interior circulation spaces. An indoor swimming pool and party space (above) occupy a separate building also facing the garden.





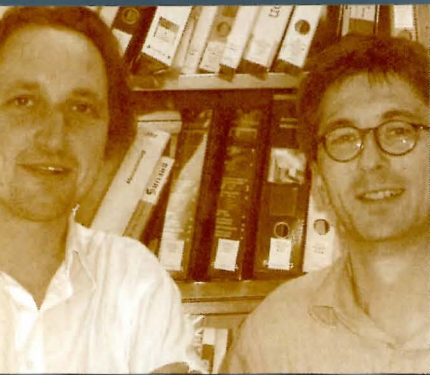

## Atelier Kempe Thill finds ways to bring together continuity and innovation

By Tracy Metz

**Architect:** Atelier Kempe Thill Architects and Planners

**Location:** Rotterdam, the Netherlands

**Founded:** 2000

**Design staff:** 10

**Principals:** André Kempe, Oliver Thill

**Education:** Kempe: Technische Universität, Dresden, Germany, Dipl.Ing.Arch., 1996; Thill: Technische Universität, Dresden, Dipl.Ing.Arch., 1996

**Work history:** Kempe: Karelse van der Meer Architecten, Rotterdam, 1997–2000; Frits van Dongen de Architecten Cie, Amsterdam, 1996–7; Thill: DKV Architecten, Rotterdam, 1997–2000; Frits van Dongen de Architecten Cie, Amsterdam, 1996–7

**Key completed projects:** Franz Liszt Concert Hall, Raiding, Austria, 2006; Terraced Houses, Roosendaal, the Netherlands, 2005; Dutch Pavilion “Hedge Building” at IGA, Rostock, Germany, 2003; Museum Pavilion “Light Building,” Rotterdam, 2001

**Key current projects:** Town houses, Amsterdam-Osdorp, the Netherlands, 2007; Apartment Block Amsterdam-Ijburg, the Netherlands, 2007; Museum for Historical Building Culture, Veenhuizen, the Netherlands, 2008; “Hiphouse” tower block, Zwolle, the Netherlands, 2008; Office Pavilion at Ministry of Justice, Rotterdam, 2008; Youth hostel, Prora, Germany, 2009; Housing Block, Den Haag, the Netherlands, 2010; Youth Centre, Amsterdam, Netherlands, 2009; Eco Housing Estate, Tienen, Belgium, 2010; Office Tower, Amsterdam, 2010

**Web site:** [www.atelierkempethill.com](http://www.atelierkempethill.com)

The young Rotterdam-based firm Kempe Thill has found architecture’s antidote to globalization: “specific neutrality.” “Most architecture is banal, gray, mass production, while at the same time the world is shouting for the unique, the special, the iconic,” says Oliver Thill in the firm’s office in the Van Nelle factory, itself an icon of 1920s industrial Modernism. “Architecture has let itself be seduced into producing pretty pictures for the media. ‘Specific neutrality’ sounds like a paradox, but we want to show that there is an architecture that can be a synthesis that expresses the hidden vitality of our time.”

Oliver Thill and André Kempe come from Dresden, where they met during their studies in the early 1990s. They worked in Japan and France and then settled in the Netherlands, where they started their own firm in 2000. Although the architectural climate in the Netherlands has since grown more conservative, their work has drawn attention, and in 2005 they were awarded the prestigious Dutch Maaskant Prize for young architects. Their core business is housing in Holland, but they also have projects in Belgium, Germany, and Austria.

Kempe Thill designs with an eye to a building’s life cycle, not just to its 15 minutes of fame. For a housing project in the Dutch town of Roosendaal, for example, the housing society said it wanted something really special and different. “But when we got down to brass tacks, it turned out that they wanted the same floor plans as they have always had. That is fine with us, but then we modernized the design by adding voids in the living spaces and full-height glass skins to the facade.” For a housing project now under construction in a postwar suburb of Amsterdam, the firm designed a structural system with a flexible floor plan, making it possible for the inhabitants to change their dwelling as their lifestyle changes through the years; hopefully, a project like this will help stabilize the neighborhood, too.

Another project that combines continuity and innovation is the team’s Franz Liszt concert hall in Raiding, Austria, next to the house where the Austrian composer was born. Inside and out it is made largely of wood and plaster, evoking the rural vernacular, but at the same time, the facades have enormous acrylic plates that not only open up the inside of the building, but also open it out to the park where the concert hall is situated.

Kempe and Thill often make their designs specific by using unusual materials. Their Acrylic Dome for the 2003 Echigo Arts Festival in Japan was an attempt at creating a new kind of dome that would provide both maximum volume and total transparency, virtually causing the architecture to disappear. The traveling museum pavilion called Light Building, of 2001, was a simple enclosure of space between walls made of translucent white plastic, this time in the form of made-to-order beer crates.

The architects are well aware that the term *neutral* is risky; it sounds beige and boring. “But it is necessary if we are to create buildings that are flexible enough to fulfill a series of different functions,” Kempe emphasizes. “We hope that by creating architecture that proves itself over time, we will help the profession to be taken seriously again.” ■

RECORD’s Amsterdam-based correspondent Tracy Metz was a Loeb fellow at Harvard in 2007, which inspired her book *On the Ground: Observations from Harvard*.





**Franz Liszt Concert Hall,  
Raiding, Austria**

This 36-foot-tall chamber music hall, next to the house where Franz Liszt was born, seats 600. The building's proportions are reminiscent of halls built in the 19th century, when the composer himself played. The interior's coffered walls are made entirely of wood; the exterior's white walls and large wooden gates allude to the rural Austrian vernacular. On the other hand, the use of polyurethane facades and large acrylic plates for the windows distances the hall from traditional models.

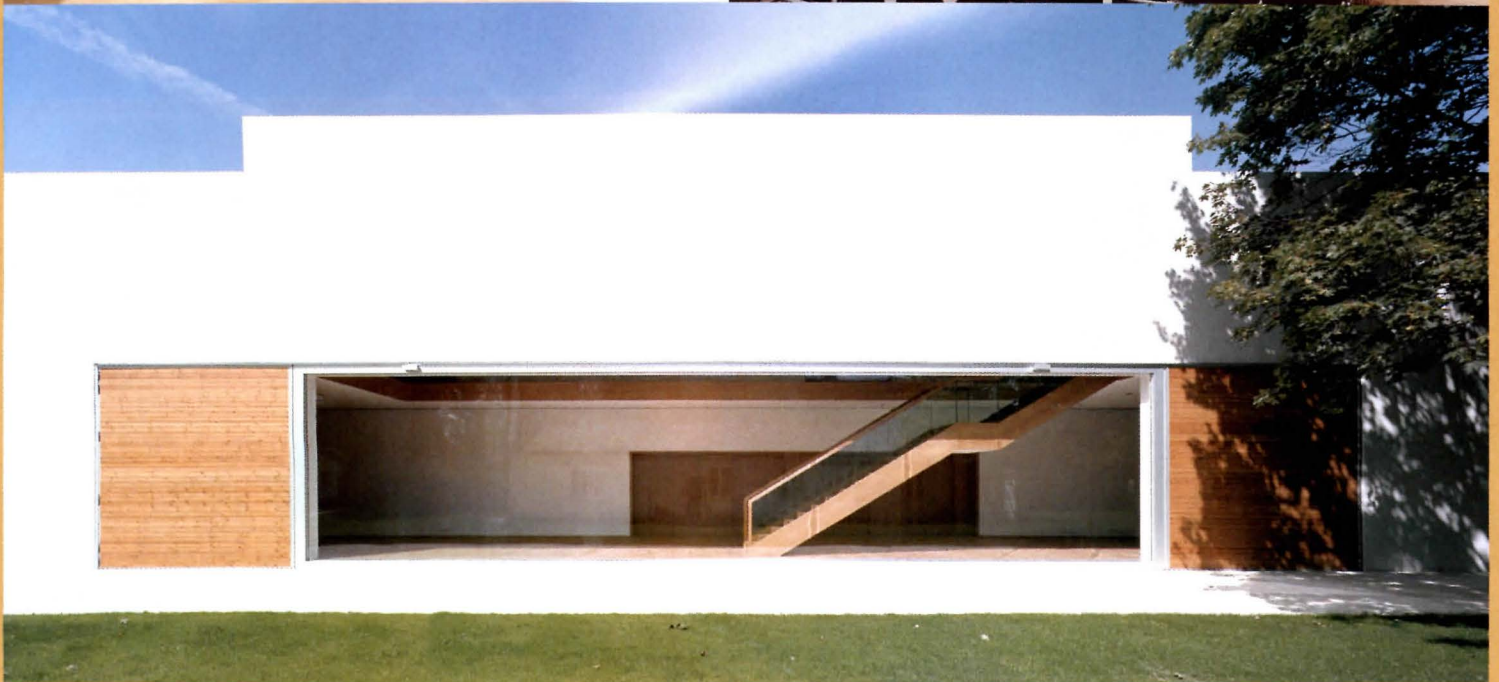



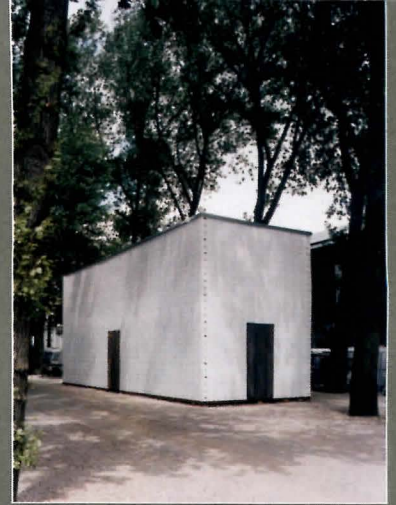
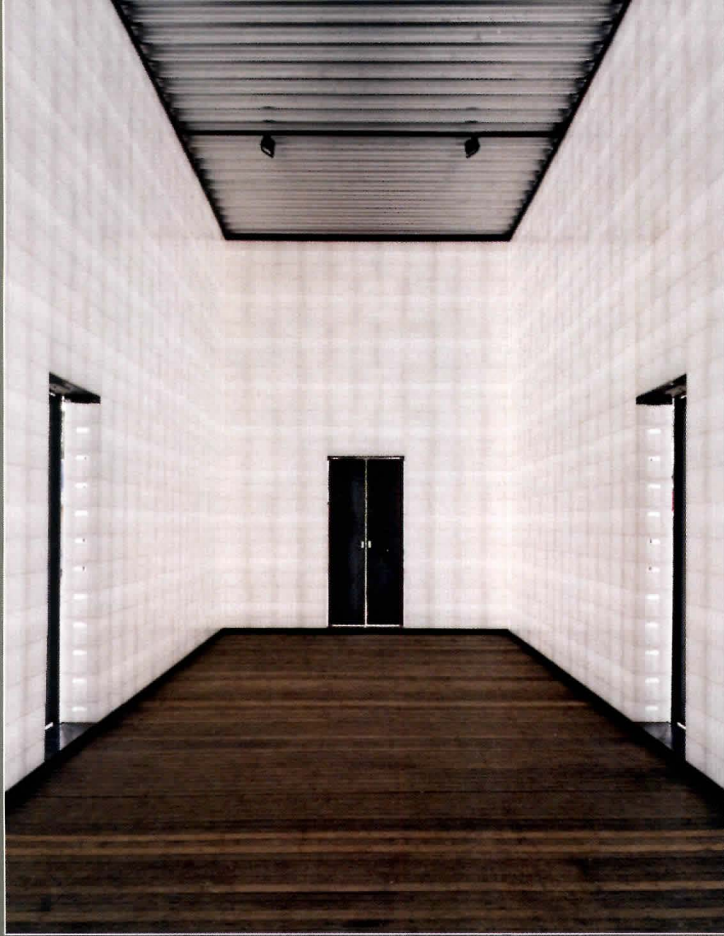

### Museum Pavilion "Light Building," Rotterdam

For this lightweight, temporary structure, the architects used beer crates as building blocks, creating a traveling museum that can be erected and dismantled by six people in one day. The crates, produced in a limited edition of white plastic, are bolted together into translucent load-bearing walls. Kempe Thill used a cheap global product here to create an almost sacral space with filtered light that is continually changing.

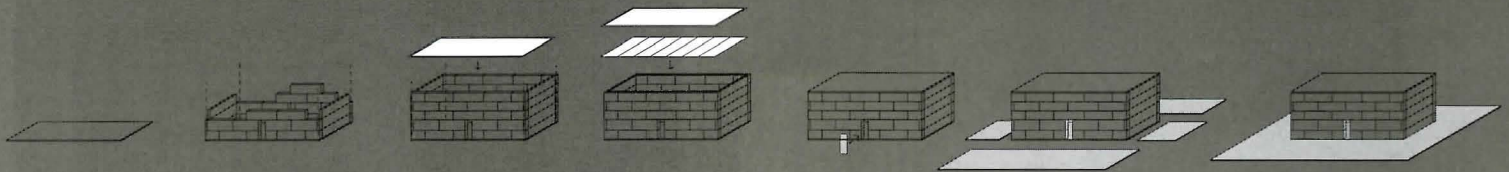

### Acrylic Dome, Visitor Center, Echigo Arts Festival, Japan



This project combines the greatest spatial volume with total transparency. It is a cupola and a window at the same time, reducing architecture to an optical minimum. The dome illustrates the relationship between contemporary society and nature: The further modern civilization evolves from nature, the more we think we yearn for it. But what we yearn for is really a visual idea, not a physical one. The Acrylic Dome brings us close to nature, but seals it off with an 8-inch-thick wall.







**Dutch Pavilion at the IGA 2003, Rostock, Germany**

This "Hedge Pavilion" at the International Garden Show embodies the logic and rationality of Dutch agriculture. It is made of "smart screens": ivy hedges grown in greenhouses that produce an instant green building. The structure is stabilized by four star-shaped corner columns, weighing 8,820 pounds each; vertical loads are carried by columns 2 inches thick. The 30-foot-high ivy walls give the pavilion the enclosed character of a house with the filtered light of a museum.

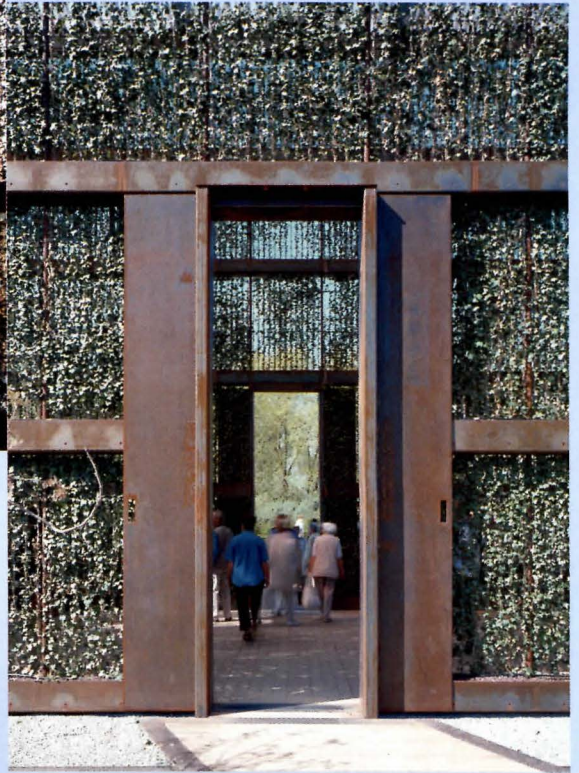





### Youth Hostel, Prora, Germany

In the 1930s, Hitler wanted to erect a 2.8-mile-long building in Prora (which later became part of East Germany) as a vacation resort for the working class. Although part of it was built, the grand scheme was never completed. Kempe Thill won first prize in a competition to convert one of the 1,500-foot-long completed blocks into a youth hostel, subtly addressing the difficult issue of how to deal with a troubled part of the county's heritage.

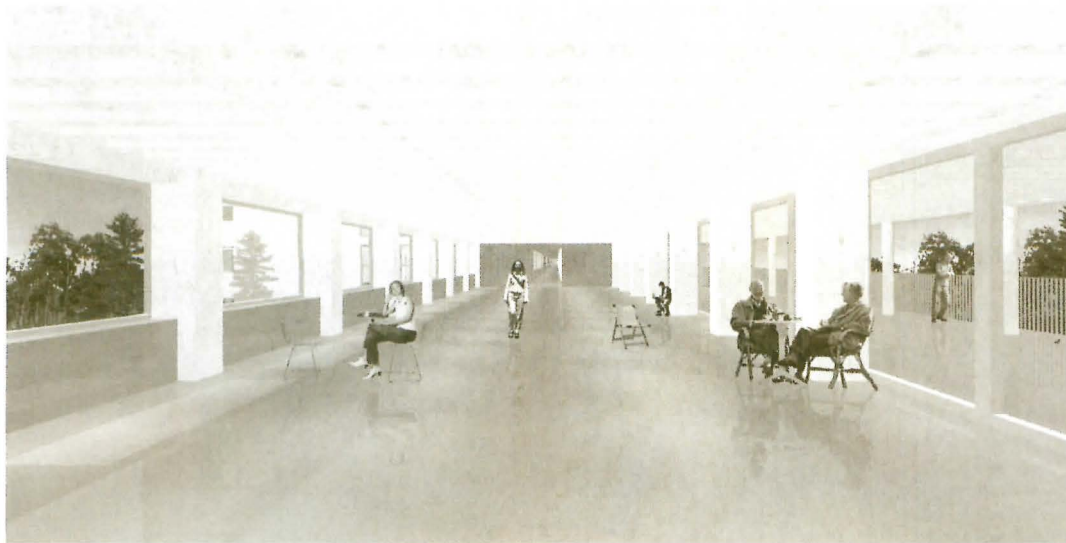



**Sky of Dimmed Light:  
Nam Jun Paik Museum,  
Kyonggi, South Korea**

In its competition entry, Kempe Thill proposed a large, long, curved exhibition hall 30 feet high, with translucent walls and ceilings. The structure is a series of arches made of massive, precast and prestressed polycarbonate columns and beams connected by polycarbonate plates and covered by extruded polycarbonate panels for insulation. The entire structure would be prefabricated and assembled on-site.

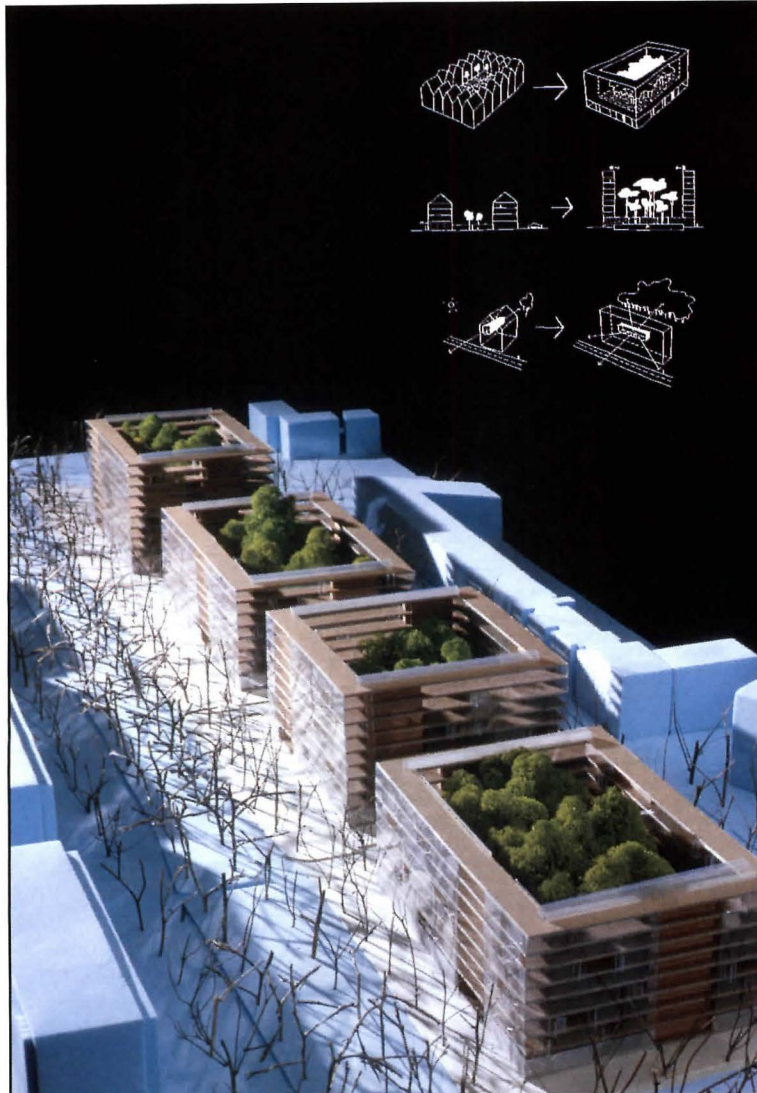
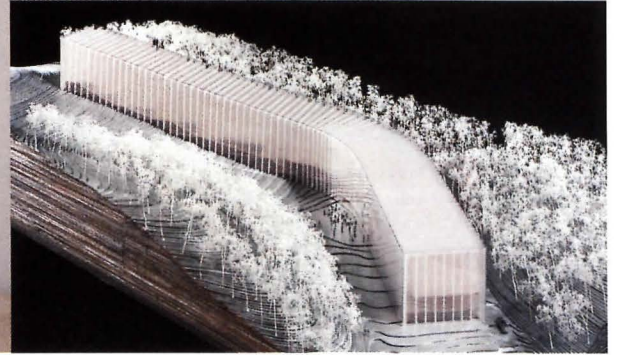

**Apartment Complex for  
European 5,  
Rotterdam**

The theme for the fifth installment of European, the European competition for young architects, was, "How to keep people in the city who would otherwise leave for the suburbs." Kempe Thill won first prize with its design for four blocks containing 300 apartments for a newly developed urban area in the south of Rotterdam. The folding glass facades can open in their entirety to form terraces facing winter gardens inside the blocks. The units themselves are simple shells with glass facades.



# BELDEN

THE BELDEN BRICK COMPANY

Canton, Ohio / (330) 456-0031

[www.beldenbrick.com](http://www.beldenbrick.com)

An ISO 9001:2000 Registered  
Quality Management System

## Sizeable Advantages.

Lower In-Wall Costs / Reduced Labor and Material Costs / Faster Construction  
Full Range of Patterns / Colors and Sizes / Energy Efficient / Enduring Beauty and Strength / Easy Upkeep

– Belden Brick meets the specifications for ASTM C 216-06; Types FBX, FBS & FBA; Grade SW –



**MODULAR  
ECONOMO**  
 $3\frac{5}{8} \times 3\frac{5}{8} \times 7\frac{5}{8}$



**MONARCH**  
 $3\frac{5}{8} \times 3\frac{5}{8} \times 15\frac{5}{8}$



**QUAD**  
 $3\frac{5}{8} \times 7\frac{5}{8} \times 7\frac{5}{8}$



**DOUBLE UTILITY**  
 $3\frac{5}{8} \times 7\frac{5}{8} \times 11\frac{5}{8}$



**DOUBLE MONARCH**  
 $3\frac{5}{8} \times 7\frac{5}{8} \times 15\frac{5}{8}$



## LABORATORY DESIGN

# Architecture's role

On university campuses, architects are faced with designing laboratories for the future while dealing with tight sites and/or limited money. Is there room for architecture?

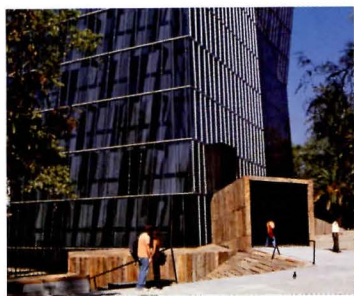

### CENTRO TECNOLÓGICO SAN JOAQUÍN

Santiago, Chile

*At the Universidad Católica, architects Alejandro Aravena, Charles Murray, Alfonso Montero, and Ricardo Torrejón generated a striking tower for digital research and teaching.*



### SKIRKANICH HALL Philadelphia, Pennsylvania

*On a tight site at the University of Pennsylvania, Tod Williams Billie Tsien Architects conceived a bioengineering laboratory building integrated with landscaped open space.*



### CALIT2 San Diego, California

*NBBJ's San Francisco office designed the University of California, San Diego's telecommunications and information center to accommodate labs for nanotechnology as well as research in computing and the arts.*

By Suzanne Stephens

**T**he lab building is not the most propitious place to look for architecture that transports us beyond the mundane: The demands of the program for various types of research too often make the manipulation of space, volume, and light seem beside the point. Then, too, clients often consider the architecture the easiest value to be “value-engineered” out of the equation when budgets are squeezed. Labs are expensive: According to Stanley Stark, FAIA, in *R&D Magazine*, the cost of new construction has increased 6 to 10 percent just this year.

Yet let's not forget some of the major 20th-century architectural landmarks involving lab design. Frank Lloyd Wright's S.C. Johnson Administration Building and Research Tower (1939–44) in Racine, Wisconsin, made history with a slim tower for labs cantilevered from a concrete core and enclosed in a skin of glass tubes. Richards Medical Research Laboratories, designed by Louis Kahn for the University of Pennsylvania in 1960, offered another prototype in which utilities were housed in blank towers, separated from others containing glazed laboratories. While the served/servant division did not prove to be that functional, Kahn went on to design an irrefutable masterwork, the Jonas Salk Institute for Biological Studies, in La Jolla, California, in 1965. Here labs occupied two parallel concrete-bar buildings with utilities positioned in deep structural ceilings.

Architects inspired by such precedents still try to be adventurous with this demanding building type. But new types of research, such as bioinformatics (mapping the human genome) or nanotechnology (building structures at the atomic and molecular level), add to the challenge. As noted by *RECORD* [July 2006, page 127], lab design today often calls for flexibility, transparency, and the fostering of interdisciplinary collaboration. Labs with open plans and internal glazing are in demand to facilitate easy visual communication. Architects design stairways and halls to promote casual interaction and informal discussion about projects.

While administrators may ask for flexible and generic lab design to prepare for the future, Victor J. Cardona, AIA, has noted in *R&D Magazine* that many researchers still want input into the design of their own spaces, including bench location and configuration. And they may desire privacy for their research. Architects confronting the changing and variable demands of lab design and its users still find it possible, as the buildings on the following pages illustrate, to emulate the creativity of a Wright or a Kahn. While it is hoped that they do so without sacrificing function, it is wise to keep in mind Jonas Salk's view. Long ago he argued that architecture—and landscape—provide the stimulating setting required for the brain to make scientific discoveries. This is indeed architecture's larger role. ■



# One: CENTRO TECNOLÓGICO SAN JOAQUÍN

## Santiago, Chile

**Architects** Alejandro Aravena, Charles Murray, Alfonso Montero, and Ricardo Torrejón **bring a riveting landmark to a college campus.**

**By Jeannette Plaut**

**Architect:** Alejandro Aravena, Charles Murray, Alfonso Montero, Ricardo Torrejón, architects; Emilio de la Cerda, collaborator

**Client:** Pontificia Universidad Católica de Chile

**Consultants:** Luis Soler y Asociados (engineering); Proingel (lighting); Gabriel Marquez (environmental); Accura systems (curtain wall)

**Size:** 51,000 square feet

**Cost:** \$3 million

**Completion date:** March 2006

### Sources

**Concrete and steel:** Serinco

**Metal/glass curtain wall:** Accura Systems

**Wood:** Arauco

**Glass:** Pilkington

An unusual building, commissioned for one of the various campuses of the renowned Pontificia Universidad Católica de Chile, demonstrates an architectonic search into the nature of traditional educational spaces. Designed to contain computer equipment and labs for the campus, this attractive volume appears to be commenting on the subtle yet strong contradiction between contemporary technology and state-of-the-art construction.

### Program

Intended to house 500 students, classrooms, laboratories, offices, and various rooms for computers, technical support, and machinery in a 51,000-square-foot structure, the design needed to take into account the restraints of low-budget construction in a remote area. With a budget of only \$400 per square meter (about \$40 a square foot), the Chilean architects Alejandro Aravena, Charles Murray, Alfonso Montero, and Ricardo Torrejón sought to create an environment where new means of learning could take place in a digital world governed by binary language.

The young architects asked themselves if increasing globalization would actually change architecture as it has been conceived so far.

*Jeannette Plaut, an architect and teacher in Santiago, is the architecture editor of Ambientes Magazine.*

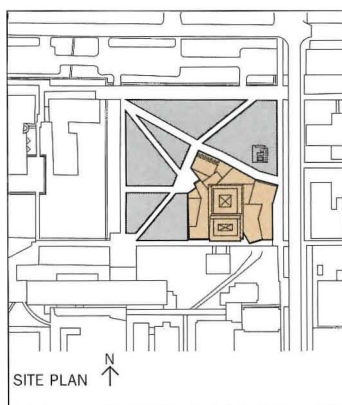

By day, the angular, double-headed Centro Tecnológico in the center of Catholic University's San Joaquín campus (left) looks opaque (above). By night, however, lighting within the concrete tower enveloped by glass (below) reveals its porosity.

They also wondered whether the traditional classroom still makes sense or if it is obsolete.

The team recognized that learning needs have changed in the digital era. For example, as Aravena explains, schools previously needed to provide ample natural light for studying. Now, with students working on computer screens, he says, "that paradigm has been reversed. We are in need of darkness, not light."



**ONLINE:** Rate this project and access additional sources at [architecturalrecord.com/bts/](http://architecturalrecord.com/bts/).



At the seventh floor, the wide-body tower separates into a double-headed form. The cranked shapes of the tempered thermal-glass envelope over the conventional poured-concrete structure is held into place by horizontal steel members. The tower-within-a-tower solution helps cut down on heat load and glare while allowing hot air in the void between the enclosures to be drawn up to the top of the building.

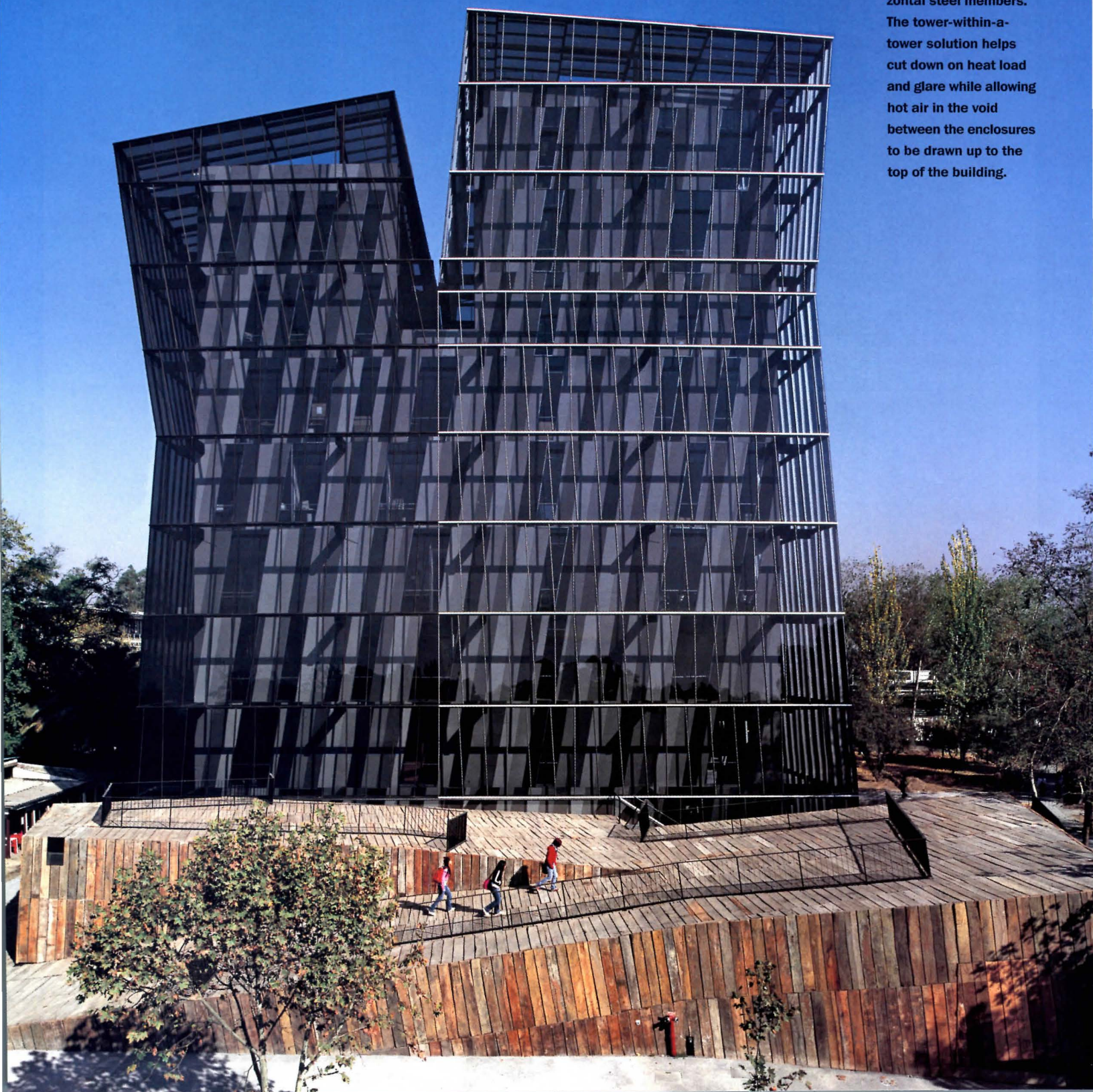



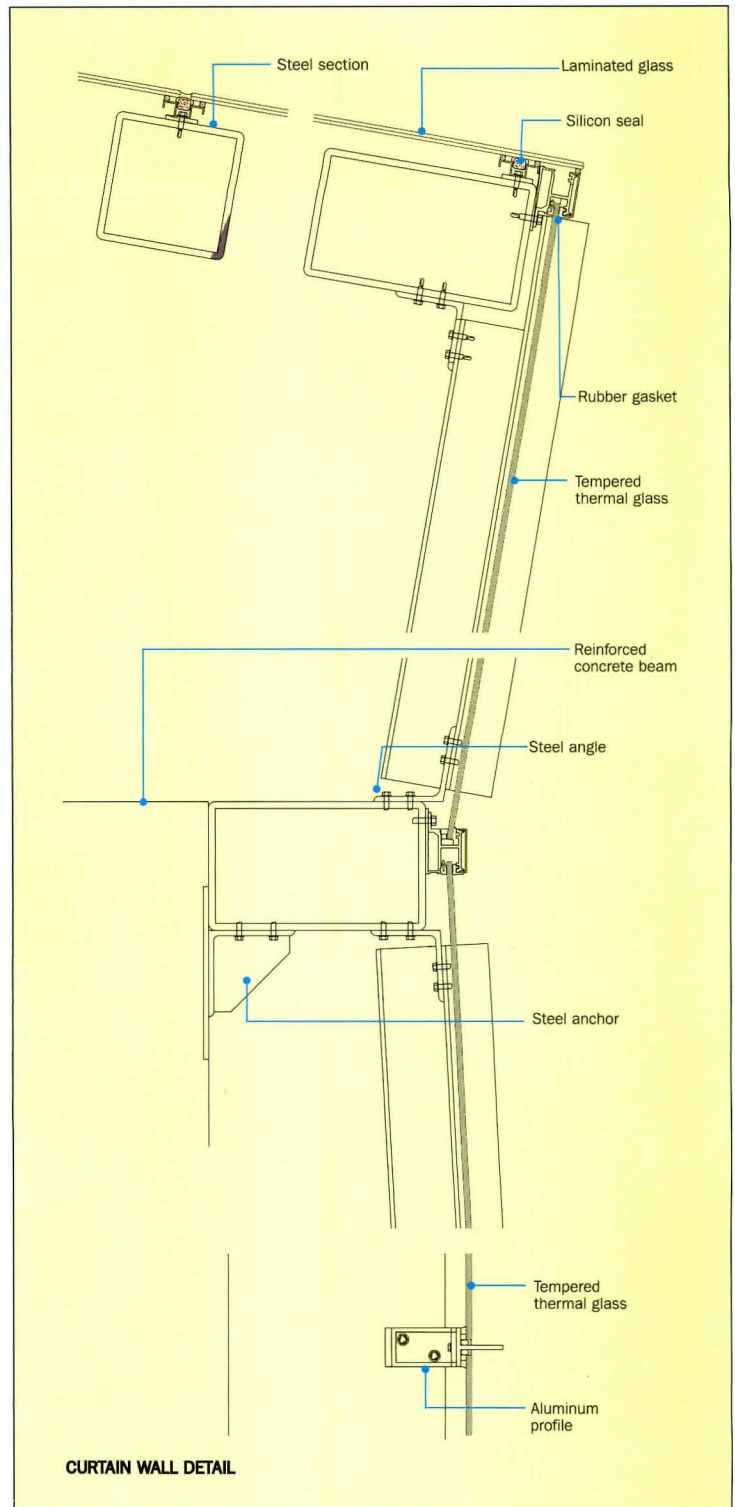
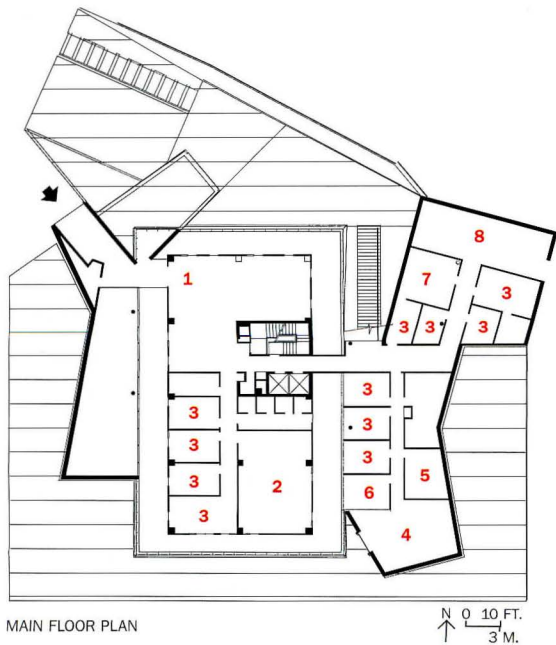
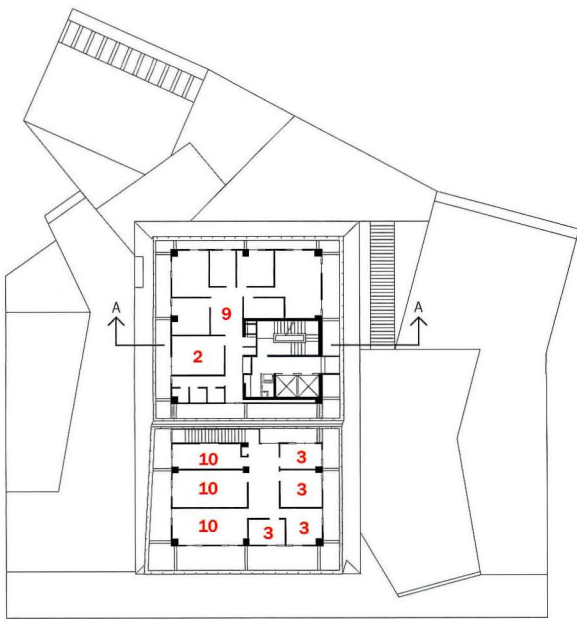
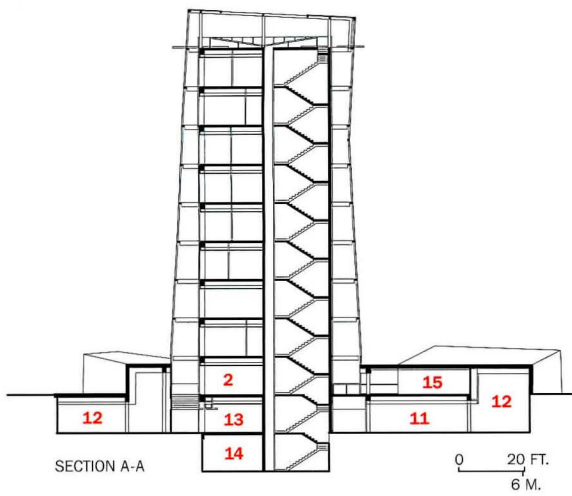

- |                       |                                       |
|-----------------------|---------------------------------------|
| 1. Lobby/exhibitions  | 10. Information and telecommunication |
| 2. Meeting room       | 11. Auditorium                        |
| 3. Office             | 12. Classrooms                        |
| 4. Technical services | 13. Study                             |
| 5. Tech support       | 14. Storage                           |
| 6. Software lab       | 15. Telecom and data support          |
| 7. Network            |                                       |
| 8. Control            |                                       |
| 9. Administration     |                                       |





Timber from railroad sleepers is used for the plaza and partially encloses sunken outdoor spaces (below right and bottom left). Aluminum panels of the inner tower vary subtly in tint (left). Along with glazed openings, a pattern can be seen through the curtain wall.

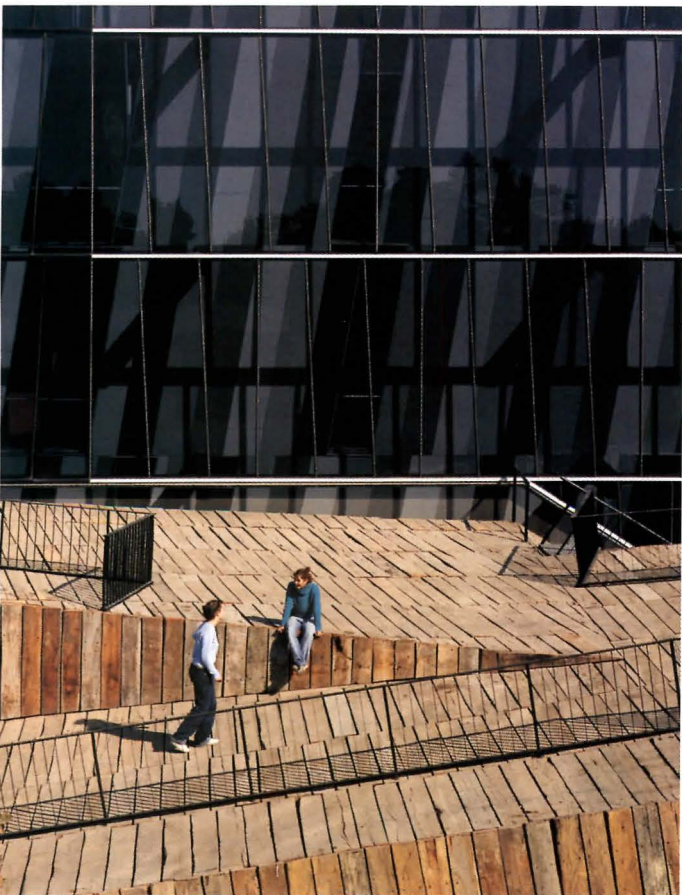





This simple yet definitive fact led us to explore a relatively hermetic volume with controlled perforations toward the outside.”

### **Solution**

In spite of the excessive optimism with which society looks upon modern technology, Aravena, Murray, Montero, and Torrejón recognized technology would never be a real substitute for a conversation between two or more people, that very archaic and at the same time effective form of transmitting knowledge from one generation to the next. And so the architects placed a wood platform—made out of railroad sleepers—at the base of the building. It provides the perfect space for students and teachers to meet between classes while it functions as the roof for the center’s two underground levels, where computer laboratories are located.

Although the university had specifically wanted a glass tower rising from the center of the campus’s main park, Aravena and his fellow architects came up with a creative solution: They designed an obliquely angled nine-story structure, which, like a tree’s branches, splits into two separate volumes at the seventh floor.

The tower appears to be a Siamese double-headed form united by a great body. Yet its bent shape is achieved while keeping both walls and columns absolutely perpendicular to each floor. The architects created the cranked configuration of the outer layer by attaching a glass curtain wall to steel arms of different lengths extending from the concrete structure. The mullions of the glass envelope echo the floor plates of the internal structure, reinforcing the spatial reading of the tower-within-a-tower.

The construction of a glass building in a polluted city where the greenhouse effect has to be addressed caused concern. By creating a glass exterior skin and cladding the building proper with thin aluminum panels of perceptible but subtle chromatic variations, the architects cut glare and heat load





within. The void between the outer and inner enclosures acts as a vertical chimney, where hot air is pulled up by natural convection to the top of the tower.

**Commentary**

With an architectonic language that articulates boldness and functionality, Aravena, Murray, Montero, and Torrejón successfully confronted this educational commission with an original solution in spite of a restrictive budget.

The result is a building that is perceived as a big boost for life on campus and one that deals positively and imaginatively with Santiago's imperfect construction conditions. The sleekly innovative structure will no doubt be considered as an important contribution to the Modern architecture of Chile. ■



**On the first level (opposite), students circulate in the void between the outer enclosure and the building proper. On this level, a computer classroom (top left) is partly glazed, with aluminum**

**panels above. On the seventh floor (top right), the hall and café offer panoramic views. Aravena designed lighting for an eighth-floor meeting room (above) and the lobby's exhibition space (right).**





# Two: SKIRKANICH HALL

## Philadelphia, Pennsylvania

Tod Williams Billie Tsien Architects knit together a complex of science buildings with a bold centerpiece structure and varied open space.

By Suzanne Stephens

**Architect:** *Tod Williams Billie Tsien Architects—Tod Williams, Billie Tsien, principals; Philip Ryan, project manager and project architect*

**Associate architect (c.d. phase):** *Guggenheimer Architects—Peter Guggenheimer, principal; Niall Cain, project architect*

**Client:** *University of Pennsylvania School of Engineering and Applied Science*

**Consultants:** *Severud Associates (structural engineers); Ambrosino Depinto and Schneider (m/e/p); GPR Planners Collaborative (lab); Propp and Guerin (environmental design); Axis Group (curtain wall and waterproofing); Fischer Marantz Stone (lighting)*

**Size:** *58,425 square feet (new construction); 12,000 square feet (renovation)*

**Cost:** *\$33.4 million (construction only)*

**Completion date:** *September 2006*

#### Sources

**Granite:** *Granicor (thermal and honed Peribonka)*

**Glazed brick:** *Castaic Brick*

**Glazed ceramic tile:** *Heath Ceramics*

**Preweathered zinc:** *Rhinezink*

**Cherry wood panels:** *Nevamar*

**ONLINE:** Rate this project and access additional sources at [architecturalrecord.com/bts/](http://architecturalrecord.com/bts/).

In 1960, the University of Pennsylvania famously fostered the notion that laboratory buildings should be architectural landmarks—emphatic physical statements about the place of advanced scientific thinking within the university. Its Richards Medical Center by Louis Kahn opened that year to great fanfare. However, in spite of Kahn's vaunted "served" and "servant" spaces, the functioning of the medical center and its research

laboratories left something to be desired. In designing Skirkanich Hall, which opened in 2006 for the university's bioengineering department in the School of Engineering and Applied Science, the New York firm of Tod Williams Billie Tsien Architects sought to create a lab building that would stand out but not compromise function. Emulating Kahn's particular solution was not part of Williams and Tsien's mission.

The architects' acclaimed

Neurosciences Institute in La Jolla, California, of 1995, demonstrated an ability to design well-functioning labs integrated into an inviting setting of open courtyards. At Skirkanich,

**The west facade is sheathed in green brick as well as acid-etched and sandblasted glass panels (below left). Here, Williams and Tsien designed elegantly rectilinear courtyards that unite the complex of engineering buildings (below).**





The main entrance of Skirkanich Hall bulges over the building line of 33rd Street (this page), and its facade angles as it follows a bend in the street. Its glass skin seems to peel away from the brick mass as panes cantilever out in shingle formation from zinc-clad profiles, according to a slight vertical incline.







The glazed lobby along 33rd Street (left) is multilevel. Massive concrete stairs to the basement (bottom left) give the lobby a sculptural presence. Similarly, on the second floor, attenuated concrete stairs activate the space linking the Towne Building and the Moore School (bottom right).

traces of their Folk Art Museum in New York [RECORD, May 2002, page 202] are visible, as well, especially in the dramatic organization of interior spaces around a central core.

At Skirkanich, the labs are straightforwardly practical. But by virtue of the interpenetration of different horizontal and vertical spaces, the play of light from skylights and expanses of glass, and most of all, the manipulation of differently textured machine-crafted materials, the architects have forged a bold architecture to promote individual research and foster casual interaction.

Manipulation of space, light, and texture: It's a promising entrée for Williams and Tsien to make in Philadelphia, where they have just won one of the most challenging commissions of this time—the new Barnes Foundation galleries, slated to rise in the next few years on the Benjamin Franklin Parkway.

### Program

Not only did the bioengineering department want to attract key researchers in this ever-expanding field, it needed to accommodate 380 undergraduate and 130 graduate students. In order to do so, the department required a new, 58,425-square-foot facility plus 12,000 square feet of renovated space in the adjoining buildings. Two teaching labs and 13 research labs, all designated “wet,” had to be included in the new structure, with two more teaching labs in the renovated spaces. Dry labs—those depending on computer research rather than chemical interactions—would stay for the most part in the department's previous home, Hayden Hall.

The building was to be inserted into a 18,500-square-foot site between two redbrick engineering







The main lobby facing 33rd Street is composed of interlocking spaces organized around a vertical light well. The mustard-yellow ceramic tile wall bounces light, and a cherry-paneled rear wall marks the hallway to the auditorium.



GRATITUDE TO  
FEYER AND GERH SWENSONSON  
F OOR E  
DANIEL H TABAS RESEARCH LABORATORY



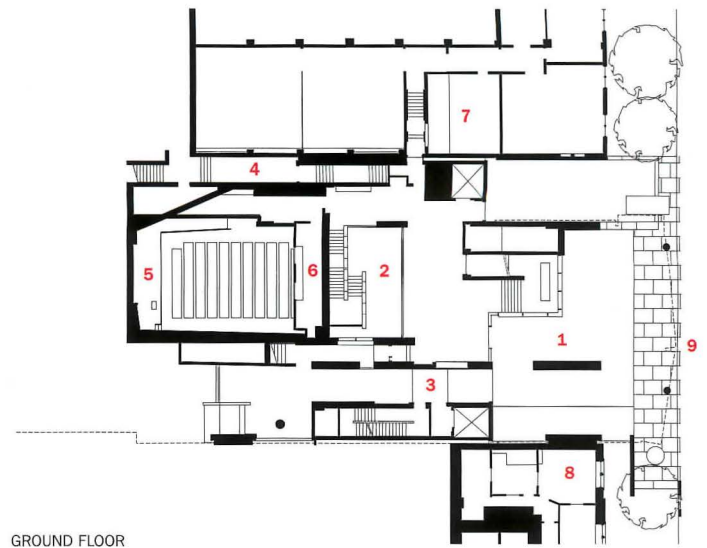
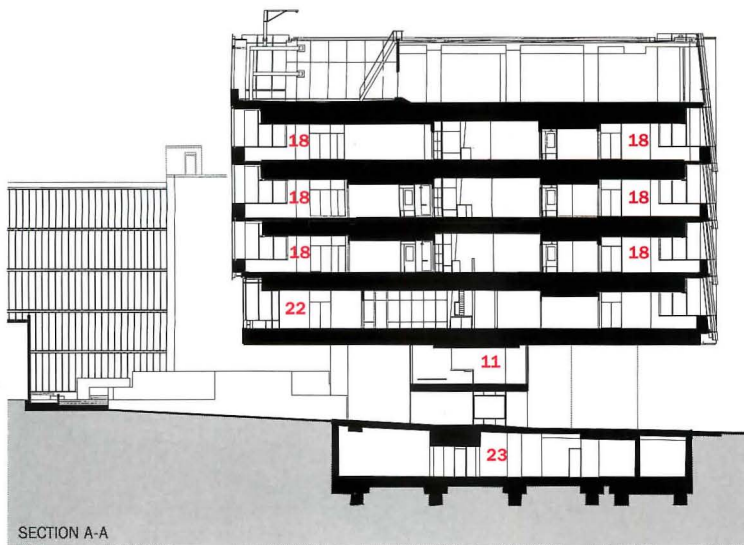

SECTION A-A

GROUND FLOOR

- |                                                                                                                                                                                                                                                                                                                                                  |                                                                                                                                                                                                                                                                                                          |
|--------------------------------------------------------------------------------------------------------------------------------------------------------------------------------------------------------------------------------------------------------------------------------------------------------------------------------------------------|----------------------------------------------------------------------------------------------------------------------------------------------------------------------------------------------------------------------------------------------------------------------------------------------------------|
| <ul style="list-style-type: none"> <li>1. Entry plaza</li> <li>2. Atrium lobby</li> <li>3. Exterior passage</li> <li>4. Balcony</li> <li>5. Auditorium</li> <li>6. Audiovisual room</li> <li>7. Moore School</li> <li>8. Towne Building</li> <li>9. 33rd Street</li> <li>10. North lobby</li> <li>11. Bridge</li> <li>12. South lobby</li> </ul> | <ul style="list-style-type: none"> <li>13. Lounge</li> <li>14. Main communications room</li> <li>15. Courtyard</li> <li>16. Levine Hall</li> <li>17. Ramp</li> <li>18. Lab</li> <li>19. Lab support</li> <li>20. Microscopy</li> <li>21. Kitchen</li> <li>22. Offices</li> <li>23. Mechanical</li> </ul> |
|--------------------------------------------------------------------------------------------------------------------------------------------------------------------------------------------------------------------------------------------------------------------------------------------------------------------------------------------------|----------------------------------------------------------------------------------------------------------------------------------------------------------------------------------------------------------------------------------------------------------------------------------------------------------|

An internal courtyard between Skirkanich and Levine Halls unites the various buildings that are part of the School of Engineering and Applied Science (below).

buildings belonging to the university's historic district; one, Moore School, is devoted to the Department of Electrical and Systems Engineering. Originally a factory for musical instruments, it was designed by Erskine and Morris in 1912, and renovated for an engineering school in 1926 by the venerated Beaux-Arts architect Paul Cret. Flanking Skirkanich Hall on the south, Towne Building, designed by Cope and Stewardson in 1906, houses the Department of Mechanical Engineering and Applied Mechanics, and the Department of Chemical and Biomolecular Engineering. Filling out the compound on the west is Kieran Timberlake's Levine Hall, completed in 2003 for computer sciences.

In the words of the engineering school's dean, Eduardo Glandt, the new hall would "speak about the synergy of the various disciplines represented in this complex." While it should fit in with the older context, Glandt still wanted to make sure the hall would stand out, with a grand entrance facing east where the campus is expanding.

### Solution

Williams and Tsien knit Skirkanich Hall into this enclave of buildings with a system of paths and internal courtyards that allows pedestrian circulation to flow unimpeded from the west to the east. In addition, students and faculty can perambulate through the connected





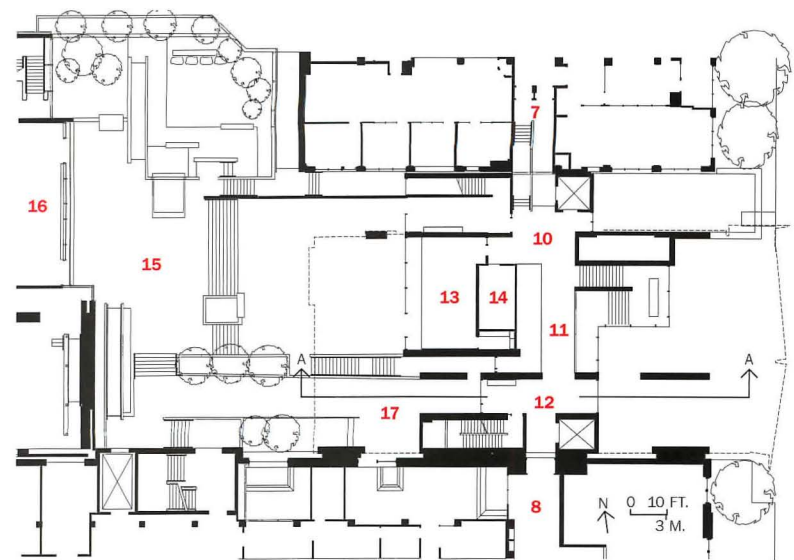

FIRST FLOOR

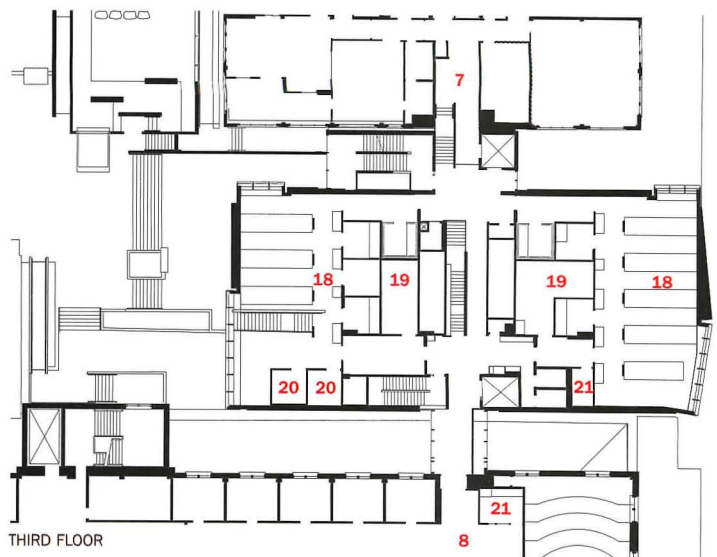

THIRD FLOOR

buildings in a square doughnut formation, so that Skirkanich can be directly entered from Moore or Towne. By placing the lab spaces at the perimeter of each of the upper floors of the reinforced-concrete structure and pushing the front of the tower over the building line of the 33rd Street entrance, the architects gained sizable work and research areas. The bulk of the building is countermanded by its slightly angled facade that follows the bend along 33rd, and the treatment of the glass skin so it appears to be peeling away from the brick mass: These acid-etched glazed portions, with sandblasted and acid-etched spandrel panels, refer rather abstractly to Philadelphia's own Queen Anne Revival shingle-and-bowed-window architecture.

In addition, the specially glazed, moss-green brick on the exterior emphatically distinguishes the building from its redbrick neighbors. For those surprised by green walls (which some students call "slimy" green), it should be noted that a similar hue can be found in two of the oldest buildings on campus, College Hall (1873) and Logan Hall (1874). Both designed by Thomas Webb Richards, they feature a green Chester Serpentine stone that was considered bizarre at the time. At Skirkanich Hall, the brick, which varies in tones of acid and moss green, has gone through considerable torture before reaching the desired tinge and texture. After the

**An auditorium underneath the plaza (right) is lined in cherry. On the second floor, a teaching lab (bottom) occupies the front portion of the building that projects over 33rd Street.**

extruded brown brick was manufactured, it was dented by a roller, then glazed with manganese and fired. Finally, it received a green vitreous glaze and was fired again. "We wanted the building to be weighty and dense," Williams says about the brick. "Architecture need not always be lightweight and ephemeral."

#### Commentary

The combination of materials—the raw, brute, bush-hammered concrete with smaller-scale green brick and yellow tiles, along with dark thermal- and honed-finish granite paving and concrete terrazzo flooring—give the building a strong, tailored, but rich look. Yet the spatial complexity and play of light filtering through glass window walls and skylights bring the textures of the materials into high relief. As students wander through and around the multileveled building, the architectonic nature of the circulation reinforces an experiential aesthetic contrasting with the plain-Jane laboratories. (Nevertheless, the labs do offer compelling views of the campus outside.)

Skirkanich Hall's sophisticated weave of exterior and interior spaces horizontally and vertically is a far cry from the stacks of boxes that usually make up lab buildings. ■





# Three: CALIT2

## San Diego, California

NBBJ's award-winning telecommunications and information technology center promotes research and interaction through design.

By Joseph Giovannini

**Architect:** NBBJ, San Francisco—Richard Clarke, principal in charge; Gabriel Blackman, senior designer; Victor Vizagatis, designer; Clarinda Bisceglia, interior designer; Fred Powell, project architect

**Client:** University of California, San Diego

**Consultants:** Rutherford & Chekene (structural engineer); Flack + Kurtz (m/e/p); Charles M. Salter Associates (acoustical); Spurlock Poirier Landscape Architects (landscape); Horton Lees Brogden (lighting); Eriksen Rattan Associates (code, hazardous material); Research Facilities Design (laboratory planning/design)

**Size:** 220,000 square feet

**Cost:** \$57 million

**Completion date:** October 2005

### Sources

**Phenolic-fiber-resin panel:** Trespa of North America

**Metal/glass curtain wall; glazing:** Tower Glass; California Sheet Metal

**Wall coverings:** Carnegie; Xorel

**Resilient flooring:** Armstrong

**Terrazzo flooring:** Mike Payne and Associates

**Paints and stains:** Frazzee

**ONLINE:** Rate this project and access additional sources at [architecturalrecord.com/bts/](http://architecturalrecord.com/bts/).

The future may be nano and wireless, but just what are the architectural implications of a building designed for developing telecommunication technologies—especially at the University of California, San Diego. Here, in the shadow of Louis Kahn's Salk Institute, the UCSD campus was designated in 1999 as one site in a network of institutes for developing and applying advanced technologies to large-scale social issues. The San Francisco office of NBBJ faced both the architectural past and future in designing a new interdisciplinary think tank, the California Institute for Telecommunications and Information Technology (Calit2), that would embody the transparent outlook of the institute and promote dialogue among its users.

### Program

The size and complexity of the program for Calit2 necessitated merging the two parcels on the north and northeast sides of an

1. Entry and gallery
2. New media-arts wing
3. Clean lab wing

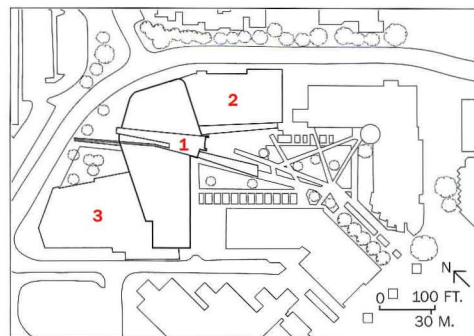

engineering quad at the bucolic campus. At the same time, the architects wanted to retain a passage through the building to a campus roadway and canyon beyond the quad. The program called for a mix of administrative offices, open labs, and individual research offices, plus dust-free "clean" labs for nano research, and a wing with a gallery and digital theaters for new media arts and scientific visualization. There would be few permanent inhabitants in a building intended to host a changing, interdisciplinary capacity of 900. Therefore, the client asked for a reconfigurable space, to blur the boundaries between spaces where people work and experiment. It wanted the building to be transparent visually and transmissive to all forms of wireless communication.

### Solution

NBBJ configured the new structure to fill the vacant site at the top of the quad, creating a courtyard bounded

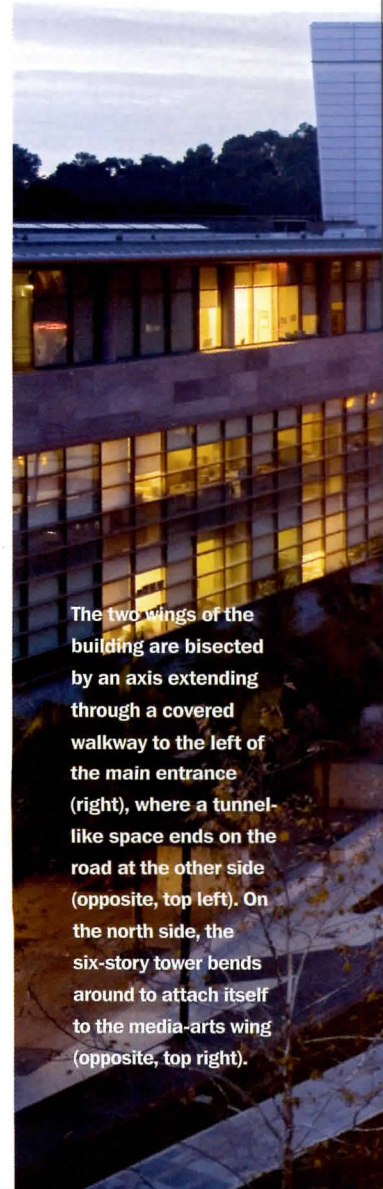

PHOTOGRAPHY: © JOHN DURANT, EXCEPT AS NOTED

The two wings of the building are bisected by an axis extending through a covered walkway to the left of the main entrance (right), where a tunnel-like space ends on the road at the other side (opposite, top left). On the north side, the six-story tower bends around to attach itself to the media-arts wing (opposite, top right).









- 1. Entry and gallery
- 2. Team space
- 3. Offices
- 4. New media arts
- 5. Clean lab
- 6. Facilities
- 7. Breakout space
- 8. Hall
- 9. Research neighborhood
- 10. Office
- 11. Labs

To promote the transmission of wireless signals, NBBJ sheathed the braced-steel-frame structure (above) in phenolic-resin-fiber panels with an insulated curtain wall.

on all sides. The architects massed the labs and offices in the east and west wings of a six-story block and extended a tall, one-story wing on the east side of the quad for the theaters and gallery. To reduce the apparent mass of the 220,000-square-foot building, the team varied each facade with different skin treatments and volumetric articulation, responding to different views and different sun and radio-wave exposures. A slotted fenestration opens the skin and channels “wave” corridors into and through the building. To augment transmissibility in the building, the architects specified a phenolic-resin-fiber panel that is largely permeable for electromagnetic waves. The rectangular front of the building, containing mostly offices and support systems, contrasts with the curvilinear form on the canyon side, which houses open-plan collaboration spaces.

Inside, wedge-shaped lobbies seem to shift the building off the orthogonal, creating a sense of unpredictability in the layout. The architects energized the lobbies by cutting open and backlighting the Sheetrock ceiling according to angular geometries generated from the site. Wide corridors designed as unprogrammed space are lined with whiteboards for chatting among scientists. The breakout spaces were conceived as neutral territory, “like a Starbucks,” says principal Brad Leathley. Faculty offices line the perimeter of the upper levels and circle open labs. Corners, left free, add more breakout space.

The labs themselves feature ceilings that carry raceways of electric wires and ethernet cables, which can drop virtually anywhere in the space, creating a highly flexible and changeable work environment.

#### Commentary

Designing a building for an enterprise devoted to the technological future in the context of everyday institutional rules anchors architecture in present-day realities.

Despite the building’s aura of the future—a whirring super frame, the angular geometries, miles of

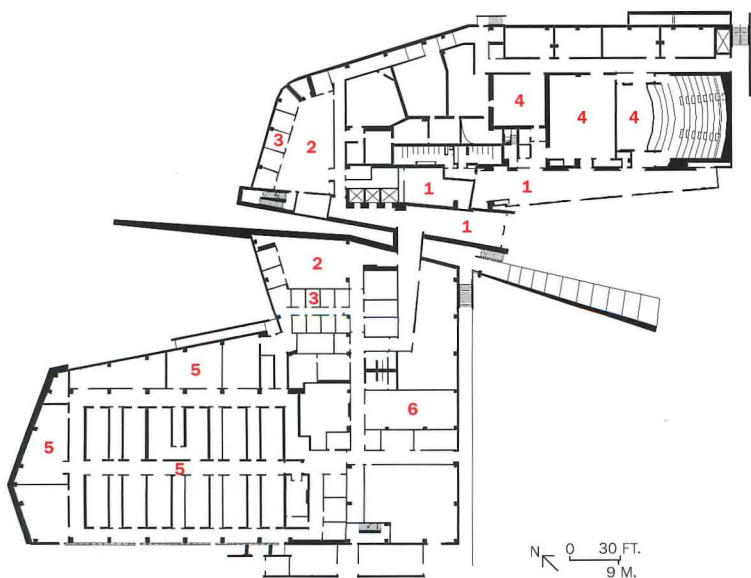

FIRST FLOOR

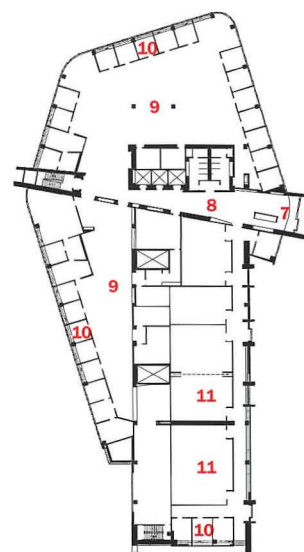

TYPICAL FLOOR





Meeting spaces are located at the ends of the wedge-shaped halls on Calit2's upper floors (above). A ramped pedestrian

passage (below left) tunnels under the structure to link to the quad's ring road. Ceilings split open at places to reveal ducts

and structure (below middle). Similarly, the diagonal braces of the steel structure are exposed in the "clean" lab wing (below right).

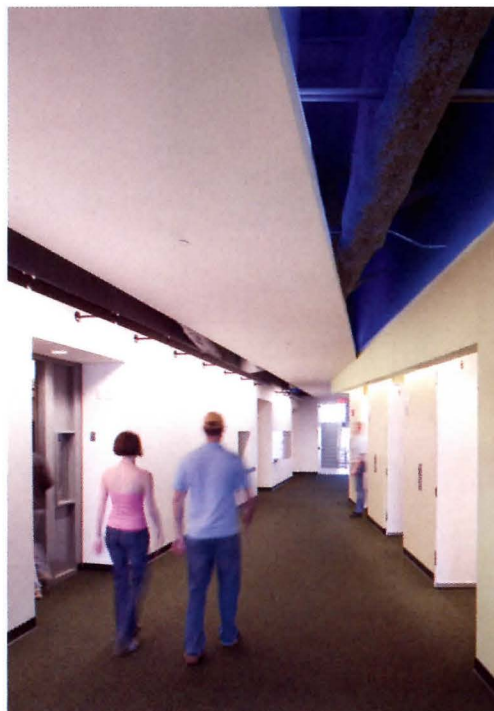





**The spaces are designed to foster communication between various research areas. The “clean” labs (above left) are glazed for visual access, while team space work areas are kept open to promote interaction (above right). The entry hall generates a flow of vertical and horizontal spaces through both a sectional cut (left) and a diagonal axis.**

cable—the underlying reality is far more simple. The differentiated facades and volumes cleverly mask a braced-steel-frame structure, with an elevator core and offices configured on an orthogonal grid that does not suggest flow of thought, or facilitate flow of people. The lab pens are simple open-floor plans. Some design features, such as the “transmissivity” windows cutting vertically across two or three floors, may help channel wireless signals, but they do not actually connect floors in a building that is largely stratified. The building has little sectional play, with no interior terracing and only a few overlooks that would encourage communication between floors. The architects make a major attempt at social engineering, encouraging informal communication with whiteboards and unprogrammed spaces, but they have not organized the corridors and floor plans into main streets that would maximize traffic.

This is a building whose program embraces technology as the unifying fact of its existence. Though the computer was undoubtedly instrumental in developing the design and the drawings, its powers were not involved in shaping the kind of breakthrough invention and vision sought at the lab benches themselves. Little has been made of the digital research occurring elsewhere in the field. At Calit2, the architectural future is still in the future. ■



# Architectural Technology

## Changing demands spur examination of materials, components, and structure

### CONTENTS

- 143** Creating Better Concrete
- 150** “Smart Glass” on the Verge
- 154** Chuck Hoberman Wants Buildings to Change
- 156** Three Medium Projects Take on the Cantilever
- 161** Software Review



This gatehouse takes advantage of the client's expertise in laser-cut fabrication (page 156).

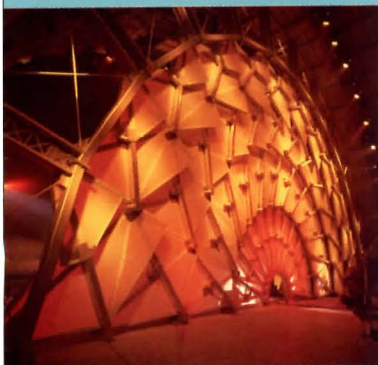

A dynamic fan-shaped proscenium amplifies the concepts underpinning a collapsible toy (page 154).

**T**his month's technology stories are far ranging but have a common thread of investigation, invention, and innovation. First, we explore concrete, a material that is hardly new but is receiving renewed attention as designers look for ways to exploit its many inherent beneficial properties. Engineers, materials scientists, and manufacturers are studying cement's production process, as well as its chemical and physical structure, in order to reduce the energy required for production.

Energy savings are also the goal of the current research covered in our piece about dynamic glazing. Though the technology has been slow to infiltrate the building-products market, both private industry and government research laboratories are investing resources in the development of commercially viable “smart glass,” which promises to be an important tool for dramatically increasing the energy efficiency of windows and predominantly glass buildings through better solar control and glare reduction. In addition to improving performance, widespread application of the glazing could have a tremendous impact on facade design.

In our Technicalities section, we look at responsive architectural elements of a different sort in a story about the work of Chuck Hoberman. The New York City-based artist, product designer, and engineer, perhaps best known for his series of collapsible toys, is now applying his expertise in mechanization to building envelopes, and at a large scale. Two current projects with London-based Foster + Partners show the potential for sustainable buildings that adapt to their environments in real time.

Our last technology feature is less about buildings that adapt to natural phenomena than about those that attempt to defy them. At the very least, the projects shown here challenge gravity: They inventively apply cantilevers to achieve a powerful presence that belies their modest size. *Joann Gonchar, AIA*



An electrochromic envelope is part of Werner Sobek's self-contained, pod-like structure for living and working (page 150).



Blend modern  
architecture within  
a historic setting...

And gird up for  
the big quake?



## WHO DOES THAT ?

We do! We're Tindall, and that's precast.

A tight site in historic downtown Charleston created unusual architectural and structural constraints for the Medical University of South Carolina's new mixed-used structure. The solution? Precast wall panels with sandblast finish and inlay brick coordinate with the historic district, while black shutters and balcony grilles blend with the modern hospital. Plus, the structure's 2-ft-thick shear walls meet the high seismic design requirements for the heavily loaded structure.

With precast design flexibility, why let the high costs of conventional construction exhaust your budget? For creative design solutions and engineered structural integrity, call Tindall Corporation today!

*Project: MUSC Parking/Retail/Offices  
Owner: Medical University of South Carolina  
Architect: Jenkins Hancock & Sides  
Engineer: Mabry Engineering  
General Contractor: Mashburn Construction  
Highlights: 700 parking spaces, blend of historic  
and modern architecture, meets high  
seismic design requirements*

Check out the entire list of creative precast solutions employed on this project at [www.tindallcorp.com/mixeduse/muschome](http://www.tindallcorp.com/mixeduse/muschome).

Tel.: 800-849-6380  
[www.tindallcorp.com](http://www.tindallcorp.com)  
Email: [sales@tindallcorp.com](mailto:sales@tindallcorp.com)

**Tindall**  
We put the Wow! in precast.



# Building Even Better Concrete

MANUFACTURERS, SCIENTISTS, AND DESIGNERS STRIVE TO REDUCE A VITAL MATERIAL'S ENVIRONMENTAL FOOTPRINT WHILE EXPLOITING ITS MANY BENEFICIAL QUALITIES



Domestic cement manufacturers are examining processes with an eye toward saving energy and reducing greenhouse-gas emissions.

## CONTINUING EDUCATION



Use the following learning objectives to focus your study while reading this month's ARCHITECTURAL RECORD/ AIA Continuing Education article. To earn one AIA learning unit, including one hour of health, safety, and welfare credit, turn to page 148 and follow the instructions. Other opportunities to receive Continuing Education credits in this issue can be found beginning on page 163.

## LEARNING OBJECTIVES

After reading this article, you should be able to:

1. Explain the cement manufacturing process.
2. Discuss the role of supplementary cementitious materials in concrete construction.
3. Discuss research and innovations in cement and concrete.

For this story and more continuing education, as well as links to sources, white papers, and products, go to [architecturalrecord.com/tech/](http://architecturalrecord.com/tech/).

By Joann Gonchar, AIA

Concrete is the most widely manufactured material, with nearly three tons produced each year for each of the earth's inhabitants. Architects value concrete for its durability, compressive strength, versatility, and expressive possibilities. However, production of cement, the fundamental ingredient in concrete, accounts for 5 percent of man-made carbon dioxide (CO<sub>2</sub>) emissions globally, according to the cement-sustainability initiative, a group of international manufacturers.

The industry is making efforts to mitigate this impact. In the U.S., for example, where cement production accounts for less than 1.5 percent of U.S. CO<sub>2</sub> emissions, according to the Portland Cement Association (PCA) estimates, manufacturers have adopted voluntary performance-improvement targets. Their goals include increasing energy efficiency 20 percent by 2020 when compared with a 1990 baseline, and on the same time line, to reducing CO<sub>2</sub> emissions by 10 percent per ton of product.

On the first goal, the domestic cement industry has already made significant progress, with a 12 percent reduction in energy use, according to a survey of U.S. and Canadian cement plants conducted annually by PCA. The trade association is now analyzing data relating to its CO<sub>2</sub> goals, but early assessments indicate that manufacturers are well





To make portland cement, manufacturers gather raw materials that include limestone, sand, shale, iron ore, and clay. The materials are blended and ground, typically using a dry process, though some older plants rely on a more energy-intensive wet process. The combined materials travel through a preheat tower (top and near left) and then to

a kiln (below far left) where temperatures reach 3,400 degrees. Inside the kiln, a chemical reaction known as calcination produces a marble-size substance called clinker. Manufacturers then cool and grind this intermediate material and add small amounts of gypsum and limestone to produce cement.

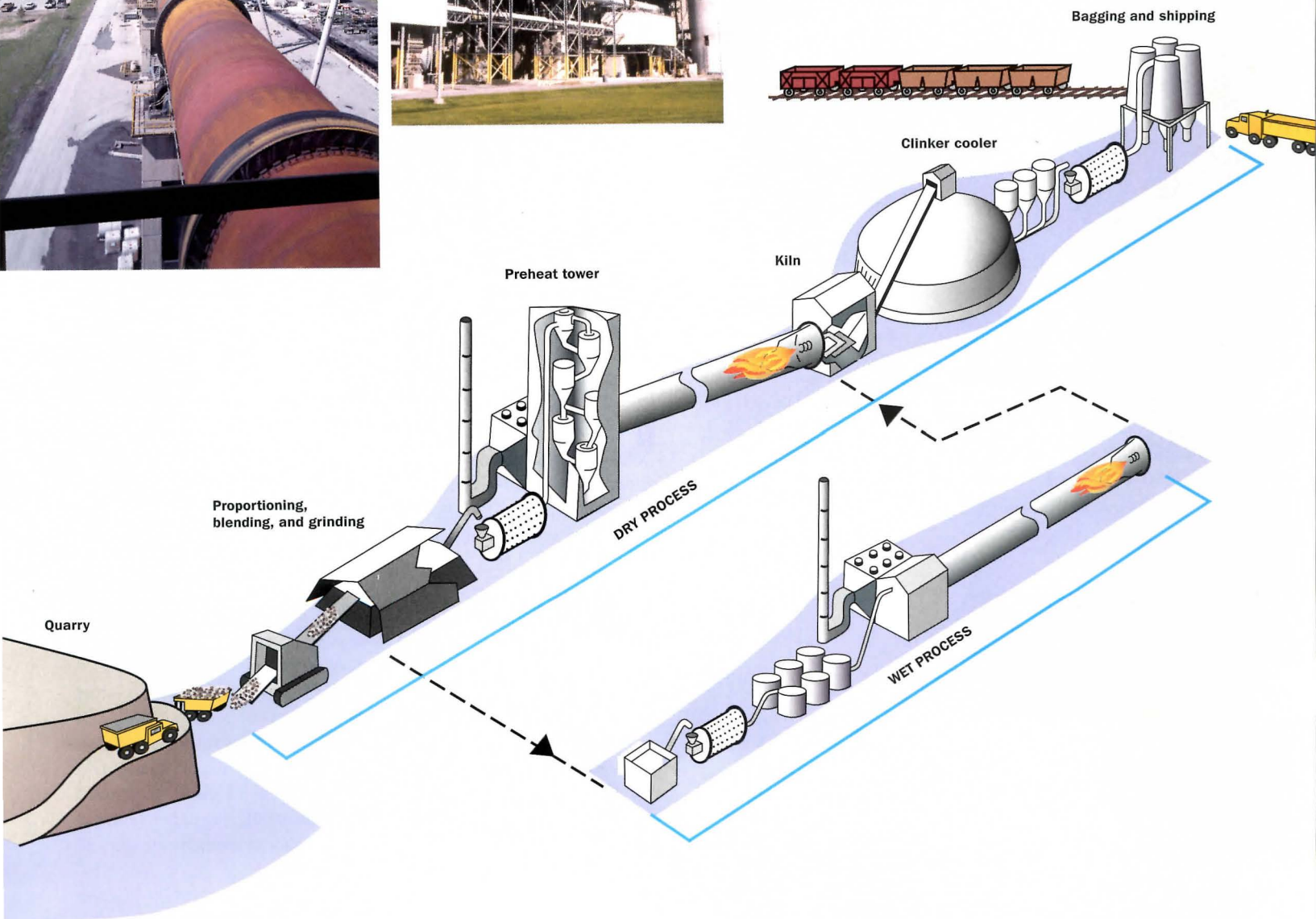



on their way to meeting emissions targets, according to Andy O'Hare, the group's vice president of regulatory affairs.

But the kind of reductions necessary to counter rising demand from emerging economies like China and India may be hard to come by, simply because of the chemistry and physics involved in cement production, which is a multistep process. To make portland cement—the binder in most concrete, typically referred to simply as cement—manufacturers first collect limestone and other raw materials, such as sand, shale, iron ore, and clay, from quarries. These materials are analyzed, blended, and ground.

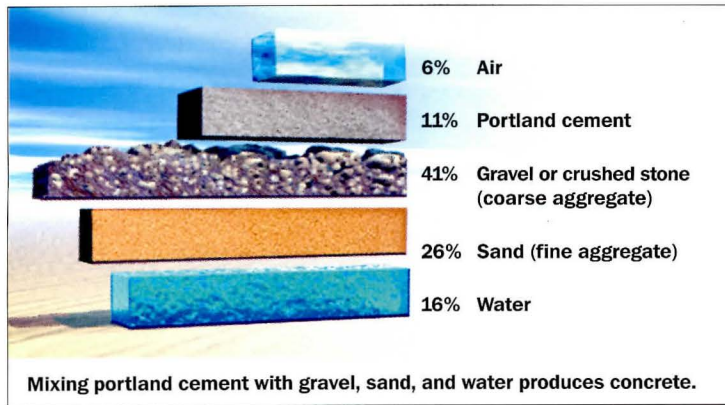

The next step expends the most energy and adds the most to greenhouse-gas production: The combined ingredients are heated at temperatures up to 3,400 degrees in a kiln where the components react and partially fuse. This chemical reaction, known as calcination, produces a marble-size substance called clinker, that is then cooled and ground with small amounts of gypsum and limestone to produce cement. Mixing the cement with sand, aggregates, and water produces concrete.

Calcination and the burning of fossil fuel required to maintain the kiln at the necessary high temperatures are responsible for about 95 percent of the greenhouse-gas emissions generated by cement manufacturing, according to O'Hare. Although manufacturers are tackling fossil-fuel consumption with strategies such as heat exchange and energy recovery from waste materials such as tires and biomass, the greenhouse gases associated with calcination will be harder to crack. "These emissions are almost impossible to reduce unless we find a substitute for limestone," says O'Hare.

#### Even concrete has DNA

And in fact, there are scientists working on identifying such a substitute. A team at the Massachusetts Institute of Technology is studying calcium-silicate-hydrate particles (C-S-H), the basic building blocks of concrete. The researchers are poking and prodding various hardened cement pastes with a nano-size needle and examining the indentations under an atomic-force microscope to better understand the material's properties. They have discovered the C-S-H has a unique "nanosignature," or genomic code, indicating that the strength of concrete does not rely on a specific mineral but on the organization of that mineral as packed nanoparticles, opening the door for identifying an alternative mineral to be used in cement.

Franz-Josef Ulm, a professor in the department of civil and environmental engineering at MIT, maintains that bone—or the apatite minerals that form the "ultrastructure" in bone—could provide a model. Like concrete, bone consists largely of calcium and "achieves a very similar packing density at the nanoscale, but is 'manufactured' at body temperature with no appreciable release of CO<sub>2</sub>," he explains. Unfortunately, hydration and hardening of these minerals take about a month. "But if we can find a way to mimic the process and speed it up, we could replicate it to fashion a new building material."

Another team, made up of scientists from the National Institute of Standards and Technology and Northwestern University, is also examining C-S-H particles at the nanoscale. The researchers are studying neutron beams as they pass through the particles to classify the location of water within the cement paste to help understand its chemical and physical structure. Though the methods and immediate interests of the two studies differ, the ultimate goals are essentially the same: "To create a stronger, more durable, and environmentally friendly material through a refined scientific understanding of C-S-H," says Georgios Constantinides, a postdoctoral researcher in materials science and engineering at MIT.

The embedded energy in concrete can also be reduced by replacing some of the cement with so-called supplementary cementitious materials (SCMs). These materials—slag cement, fly ash, and silica fume—are waste products of other industrial processes. Slag is a by-product of steelmaking, while fly ash is created when coal is burned at power plants and other industrial facilities. Silica fume is a by-product of silicon and ferrosilicon metal production. The use of these materials reduces the amount of virgin material in concrete and also conserves landfill space. The strategy of replacing cement with SCMs is "dilution as a solution to pollution," says O'Hare.

Replacement of cement with SCMs can also impart physical benefits to concrete. For example, the addition of slag can create, generally speaking, concrete that is more dense and less permeable to water, and therefore more durable. One possible drawback is that mixes with high percentages of slag can take longer to gain strength. However, even though it is slower to set, slag cement can ultimately achieve higher compressive strengths than conventional concrete.

Although slag cement's longer set time could in theory mean slower construction, many designers and contractors say that they have

## NANOSCALE INVESTIGATIONS COULD YIELD A STRONGER, MORE DURABLE, AND ENVIRONMENTALLY FRIENDLY CONCRETE.

not experienced delays related to use of high percentages of the supplementary material. Andrew Mueller-Luster, a principal at New York City-based structural engineer Severud Associates, says that even in sub-zero temperatures, contractors maintained a two-day pour cycle on the Helena, an apartment building on the West Side of Manhattan. The concrete mix for the 600-unit Helena, designed by FXFowle and completed in late 2005, contained 45 percent slag. Severud has so far used the mix on three New York City projects, including One Bryant Park, the recently topped out office tower designed by Cook+Fox. "We have not seen delays materialize," says Mueller-Luster.

Construction industry insiders say that concrete containing at least small quantities of SCMs is now more usual than that without. Use of slag and fly ash "is now as common as unleaded gas," says Mel Ruffini, senior vice president of Tishman Construction in New York City.

A few researchers are hoping to use these normally supplementary ingredients to completely replace cement. Civil engineers at Montana State University are working on using locally available high-calcium fly ash as the sole binder in structural-grade concrete. Since the summer of 2002, they have successfully completed a handful of field trials on small structures, including a residential foundation, using conventional mixing, transporting, and placement equipment.

The team members' first challenge was the mix's short set time, but they have since learned to control it by adding borax as a retarder. "By adjusting the admixture, we can dial in the set time, from 1 to 5 hours," says Jerry Stephens, a professor at the university's Western Transportation





Use of by-products from other industrial processes in cement mixes can help conserve virgin material and landfill space. Two New York City projects that include a high percentage of blast-furnace slag, which is a by-product of steel-making, are the recently topped-out Cook+Fox-designed One Bryant Park (left and above), and the Helena (right), by FXFowle.



Institute. A huge unknown that remains, however, is durability, and they plan accelerated testing for such factors as freeze-thaw performance. “The material doesn’t have the history of portland cement,” concedes Stephens.

#### The whole building

Though cement production is energy-intensive and CO<sub>2</sub>-emitting, if architects focus exclusively on these aspects of the material, they run the risk of forgoing performance efficiencies that concrete can provide, especially when used as part of a whole-building approach to design. One example of a project that is the outcome of such a process is the recently completed U.S. Federal Building in San Francisco [RECORD, August 2007, page 96]. Half of the cement in the 18-story tower’s exposed reinforced-concrete structure was replaced by blast-furnace slag, preventing release of about 5,000 tons of CO<sub>2</sub> into the atmosphere, according to estimates from

Morphosis, the project’s architect. But even more noteworthy is the building’s reliance on natural ventilation to cool its upper 13 floors. The concrete structure and its thermal mass are key components of this strategy.

The tower has a building automation system (BAS) that controls operable components in its exterior window walls. The BAS opens these apertures to cool, or “charge,” the concrete during the night, when warm weather is expected the next day. Once the structure’s temperature has dropped sufficiently, the BAS closes the openings. Then, during the day, heat generated by occupants, computers, and lights is transferred to the slab by radiation.

The architects and engineers worked together to find the structural configuration that would provide maximum cooling. One decision made in order to enhance the performance of this system was to use normal-weight concrete despite the possible structural benefits of using



The Morphosis-designed San Francisco Federal Building relies on natural ventilation and an exposed reinforced concrete to cool the upper floors of the 18-story tower (below). The office areas (right) feature exposed slabs that have a wave profile in section. The configuration provides a large surface area and aids absorption of heat.

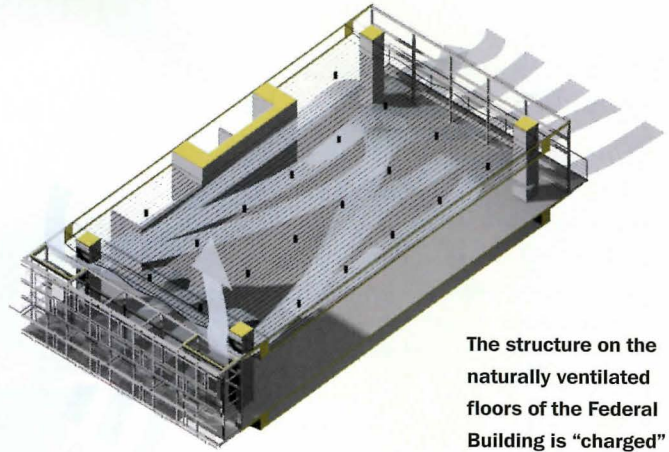

The structure on the naturally ventilated floors of the Federal Building is "charged" at night when operable components in the exterior window walls are opened.

lightweight concrete in the highly seismic region. The entrained air in the lighter material would have made the structure act like an insulator. Instead, a structure that quickly absorbed and released heat was required, explains Steve Ratchye, now an associate in the Los Angeles office Thornton Tomasetti. Ratchye was formerly project structural engineer for Arup, the m/e/p and structural consultant on the Federal Building.

Another feature of the structure that aids the natural ventilation strategy is its raised floor/upturned beam configuration. By avoiding perimeter beams, the designers enhanced the flow of air, the penetration of daylight, and access to views. The slab has a wave profile in section, providing a larger surface area than a flat slab, enhancing its ability to absorb heat. In the design of this element, the requirements of thermal mass, architecture, structure, and daylighting all coincide, says Ratchye.

In addition to more emphasis on an integrated approach to

design like that employed for the Federal Building, new technology, such as ultra-high-performance concretes (UHPC), could help architects produce more environmentally benign buildings. One UHPC is Ductal, introduced several years ago and developed by chemical company Rhodia, the construction arm of Bouygues, and building products manufacturer Lafarge. It incorporates metallic or organic fibers and does not require reinforcement. Because its compressive strength is 6 to 8 times greater than conventional concrete, the material allows for smaller structural members and therefore has fewer associated greenhouse-gas emissions. According to a study commissioned by Lafarge comparing a bridge made of Ductal to one with a conventional concrete-and-steel structure, the Ductal-only solution required 50 percent less material by volume, which translated into a 50 percent reduction in CO<sub>2</sub> emissions, explains Vic Perry, Ductal general manager, Lafarge North America. The



study takes into account not only embedded energy, but also reduced maintenance needs over a projected 60-year life span, he explains.

Another recently introduced cement, TX Active, has environmental benefits discovered almost by accident. The material, which contains titanium dioxide, was first developed by Italian manufacturer Italcementi for Richard Meier's Jubilee Church, in Rome [RECORD, February, 2004, page 101], to help to maintain the building's brilliant white appearance in perpetuity. But scientists later discovered that the product acts as a photocatalyst, using light to help break down airborne pollutants, such as particulate matter, volatile organic compounds, and nitrogen oxides. To some extent, conventional concrete also breaks down pollutants, explains Dan Schaffer, product manager for Essroc Cement, the U.S. distributor. "But the titanium dioxide accelerates the process," he says.

Since completion of the Meier building in 2003, the product has been used on several European projects, but has not yet been specified in the U.S. One prospect is a "superabsorber" developed by fieldoffice, a Clemson, South Carolina-based architectural practice. The firm first proposed using the material to create spongelike highway barriers that would dissipate the light, sound, and air pollution generated on heavily

**Highway barriers by fieldoffice, made of photocatalytic cement, could protect adjacent areas from traffic-generated air, sound, and light pollution.**

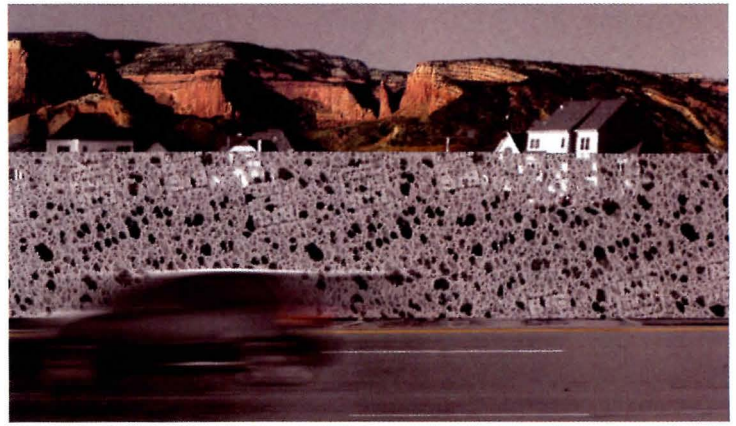

traveled roadways. But now several school districts are interested in deploying the porous panels to help improve air quality at urban sites, according to Doug Hecker, fieldoffice principal. Hecker is exploring both 3D printing and more conventional forming methods for producing the panels, which at least in his initial concept, were to be nonrepeating. But more practical concerns have taken over: "We are now investigating ways a limited number of panel types can be combined to produce different effects," he says. ■



## AIA/ARCHITECTURAL RECORD CONTINUING EDUCATION

### INSTRUCTIONS

- ◆ Read the article "Building Even Better Concrete" using the learning objectives provided.
- ◆ Complete the questions below, then fill in your answers on the next page.
- ◆ Fill out and submit the AIA/CES education reporting form on the next page or download the form at [archrecord.construction.com](http://archrecord.construction.com) to receive one AIA learning unit.

### QUESTIONS

1. Which is the fundamental ingredient in concrete?
  - a. cement
  - b. carbon dioxide
  - c. fly ash
  - d. calcium
2. The goals of the cement industry in the U.S. include which?
  - a. increase CO<sub>2</sub> production to 2.8 percent
  - b. increase energy efficiency by 20 percent by 2020
  - c. reduce CO<sub>2</sub> emissions by 20 percent by 2020
  - d. decrease energy efficiency by 12 percent by 2020
3. The most energy-intensive and greenhouse-gas-producing part of making cement is which?
  - a. mining of limestone and other raw materials
  - b. cooling clinker
  - c. the chemical process that produces clinker and the combustion of fuel required to maintain the necessary high temperatures
  - d. transportation
4. The greenhouse gases associated with calcination would be hard to significantly reduce unless a substitute is found for which?
  - a. calcium
  - b. cement
  - c. limestone
  - d. clinker
5. The apatite minerals in bone provide a good model for a cement because of
  - a. all of the following qualities except which?
    - a. the minerals consist largely of calcium
    - b. the minerals have a similar packing density to cement at the nanoscale
    - c. the minerals are manufactured at temperatures under 100 degrees
    - d. the minerals' hydration and hardening take minimal time
6. An example of supplementary cementitious material is any except which?
  - a. slag
  - b. gravel
  - c. fly ash
  - d. silica fume
7. The addition of slag can create concrete that is which?
  - a. more dense
  - b. more permeable to water
  - c. quicker to gain strength
  - d. has a lower compressive strength
8. Fly ash is a by-product of which process?
  - a. calcination
  - b. the manufacture of silicon or ferrosilicon metals
  - c. coal burning
  - d. steel making
9. A concrete that contains titanium dioxide can provide which beneficial result?
  - a. stronger concrete
  - b. lighter concrete
  - c. improved air quality
  - d. heat-absorbing concrete
10. All of the following describe the U.S. Federal Building in San Francisco except which?
  - a. heat generated by occupants, computers, and lighting is transferred to the slab via radiation
  - b. the building-management system opens operable components to charge the structure
  - c. it relies on natural ventilation and thermal mass
  - d. it runs chilled water through the concrete slabs





**Program title: "Building Even Better Concrete," Architectural Record (12/07, page 143).**

127EDIT1

AIA/CES Credit: This article will earn you one AIA/CES LU hour of health, safety, and welfare credit. (Valid for credit through December 2009.)

Directions: Select one answer for each question in the exam and completely circle appropriate letter. A minimum score of 80% is required to earn credit. Take this test online at <http://archrecord.construction.com/continuing/default.asp>.

- |      |   |   |   |       |   |   |   |
|------|---|---|---|-------|---|---|---|
| 1. a | b | c | d | 6. a  | b | c | d |
| 2. a | b | c | d | 7. a  | b | c | d |
| 3. a | b | c | d | 8. a  | b | c | d |
| 4. a | b | c | d | 9. a  | b | c | d |
| 5. a | b | c | d | 10. a | b | c | d |

Last Name \_\_\_\_\_ First Name \_\_\_\_\_ Middle Initial or Name \_\_\_\_\_

Firm Name \_\_\_\_\_

Address \_\_\_\_\_ City \_\_\_\_\_ State \_\_\_\_\_ Zip \_\_\_\_\_

Tel. \_\_\_\_\_ Fax \_\_\_\_\_ E-mail \_\_\_\_\_

AIA ID Number \_\_\_\_\_ Completion date (M/D/Y): \_\_\_\_\_

**Check one:**  \$10 Payment enclosed. (Make check payable to *Architectural Record* and mail to: Continuing Education Certificate, P.O. Box 5753, Harlan IA 51593-1253.) For customer service, call 877/876-8093.

**Charge my:**  Visa  Mastercard  American Express **Card#** \_\_\_\_\_

**Signature** \_\_\_\_\_ **Exp. Date** \_\_\_\_\_

**Check below:**

- To register for AIA/CES credits:** Answer the test questions and send the completed form with questions answered to above address, or fax to 888/385-1428.
- For certificate of completion:** As required by certain states, answer test questions, fill out form above, and mail to above address, or fax to 888/385-1428. Your test will be scored. Those who pass with a score of 80% or higher will receive a certificate of completion.

**Material resources used:** Article: This article addresses issues concerning health and safety.

**I hereby certify that the above information is true and accurate to the best of my knowledge and that I have complied with the AIA Continuing Education Guidelines for the reported period.**

**Signature** \_\_\_\_\_ **Date** \_\_\_\_\_



Inspiring.  
Majestic.  
Extraordinary...

and the  
architecture  
isn't bad either.



[www.bklighting.com](http://www.bklighting.com) • 559.438.5800 • [www.tekaiillumination.com](http://www.tekaiillumination.com)





R129 is a prototype in development at the Laboratory at the Institute for Lightweight Structures and Conceptual Design at the University of Stuttgart. The skin will be coated with an electrochromic foil, which allows the entire envelope to be made opaque, either in sections or as a whole.

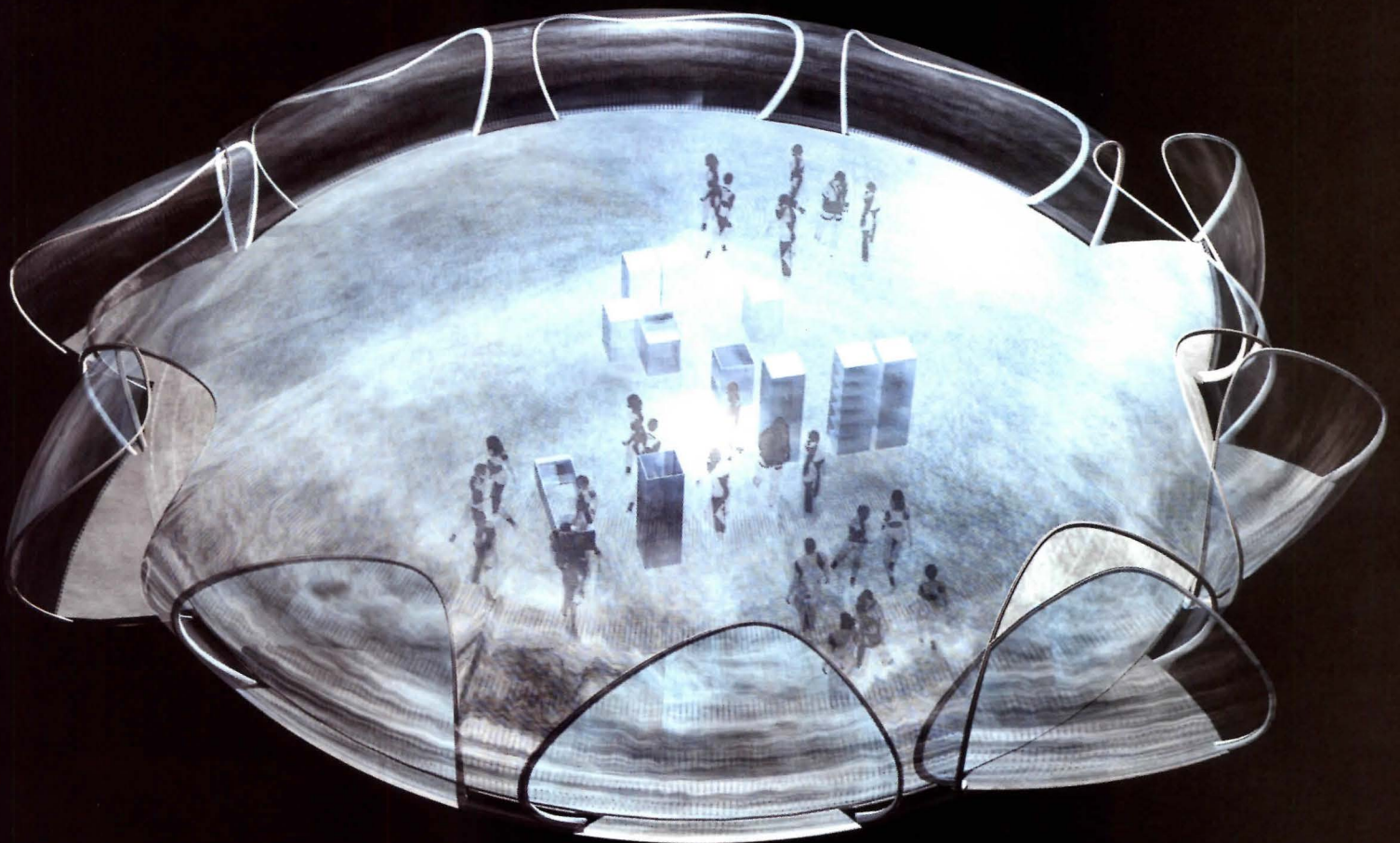



# “Smart Glass” on the Verge

AFTER LANGUISHING FOR YEARS OUTSIDE THE MAINSTREAM, “SWITCHABLE GLAZING” IS POISED TO BECOME A VIABLE ALTERNATIVE AND COULD SOON HAVE A SIGNIFICANT IMPACT ON FACADE DESIGN

By Sara Hart

Most people are familiar with sunglasses that have photochromic lenses. Commercially available since 1983, the lenses darken in response to ultraviolet light and revert to clear when the exposure is removed. Though it may not seem like much of a leap from eyeglasses to windows, this technology has been slow to infiltrate the building-products marketplace.

But now it appears that both private- and government-sponsored research could soon make more energy-efficient building products widely available. One of the areas receiving considerable attention is “switchable glazing.” The National Renewable Energy Laboratory (NREL), the Department of Energy’s (DOE) primary laboratory for renewable energy and energy-efficiency research, has focused much of its attention on windows, and with good reason. NREL reports, “Windows contribute about 30 percent to building heating and cooling electrical loads nationwide. Thus, potential energy savings from the wide-scale use of advanced windows is nearly 6 percent of the national energy consumption.” NREL’s research includes advanced window concepts, particularly those combining high thermal efficiency and dynamic transmittance of light. A key area of research activity is in switchable glazing, also known as “smart glass,” for a variety of residential and commercial applications. The goal is to create a viable product to control the light and gain transmittance through windows. The benefits are clear: reducing light reduces glare; reducing solar gain reduces energy costs; and controlling transparency controls privacy.

“Smart glass” and “switchable glazing” are generic terms that refer to all types of passive and active systems. Photochromic and thermochromic glazing, which are light- and heat-sensitive, respectively, are considered passive, because they do not require electricity. Those transitional sunglasses are smart, but passive. Active-control or electrochromic systems offer more options, but must be hard-wired to a power source.

Active technologies are the focus of most of the current research. Electrochromic windows are generally considered to be the most suitable chromogenic technology for energy control in buildings. They reduce or block light transmission and alter transparency in response to environmental signals, such as glare, sunlight, or temperature. The change from transparent to tinted is achieved when a small electrical current is applied to the window. The window returns to transparent when the voltage is turned off. Light transmittance during operation varies from 5 to 80 percent. Once the change in tint is initiated, the electrochromic glazing does not need constant current to maintain the tinting. In addition, the film can be tuned to block certain wavelengths, such as solar (heat) energy.

Electrochromic windows are made up of several extremely thin plies. Darkening occurs when hydrogen or lithium ions from an ion-storage layer are transmitted through an ion-conducting layer, which, when a voltage is applied, hurls the ions into an electrochromic layer typically made of tungsten oxide. The ions cause this layer to absorb visible light, thus darkening the window’s glass. The thin plies are sandwiched between two sheets of a transparent conducting oxide material. Finally, all the layers are encased

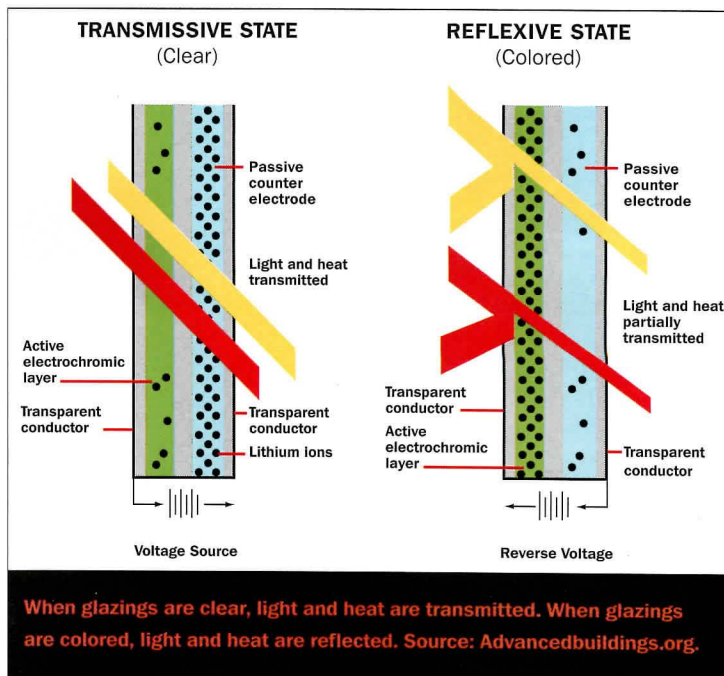

between two layers of glass. (Gasochromic windows are similar to electrochromic, but rely on diluted hydrogen in the cavity of the insulated window unit to effect color change.) The main advantage of electrochromic windows is that they typically require low-voltage power, remain transparent across their switching range, and can be modulated to any intermediate state between clear and fully darkened.

Some of the most exciting electrochromatic research is taking place at the Lawrence Berkeley National Laboratory (LBNL), another DOE agency. Tom Richardson and Jonathan Slack of the lab’s Environmental Energy Technologies Division are developing switchable-mirror (reflective) technology. By avoiding the rare earth metals originally used in metal-hydride switchable mirrors, Richardson and Slack expect to lower the cost and simplify manufacturing. Energy performance is also improved, since the new windows can reflect or transmit both visible and infrared light.

“We are working to make reflective, electrochromic windows,” explains Richardson. “These would give the user more control of the relative reflectance/transparency than is possible with gasochromic windows. Reflective electrochromic windows have several advantages relative to both the static low-E products now used in nearly all new construction and to the absorbing electrochromic windows now on the market. They can become opaque to provide privacy and control glare even in direct sun.” Because one can choose to admit or reject solar energy at all wavelengths, they offer better savings on heating, cooling, and lighting costs. They also do not get as hot in direct sunlight and, in principle, should be less expensive to manufacture.

Two other types of switchable glazing are called liquid crystal device windows and suspended particle device windows (SPD). Liquid crystal technology has been used for some time in wristwatches and is gaining popularity as privacy glazing. A thin layer of liquid crystals is sandwiched between two transparent electrical conductors on thin plastic films, and the



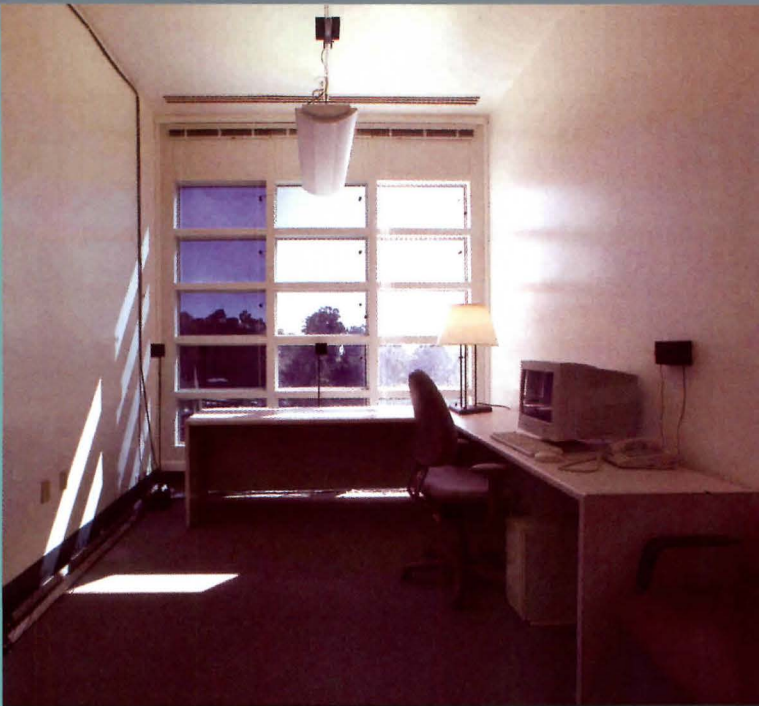

entire device is laminated between two layers of glass. When power is off, the liquid crystals are in a random and unaligned state. They scatter light, which makes the glass become translucent, thus obscuring direct views and providing privacy. This type is used most often in interior applications, including bathrooms, conference rooms, and changing rooms in retail stores.

SPDs, on the other hand, start out dark and become transparent when voltage is applied. They are made of an electrically controlled film with a thin, liquidlike layer in which molecular particles are suspended between sheets of glass. When electricity comes into contact with the SPDs, which have a transparent conductive coating, they line up in a straight line and allow light to flow through. Once the electricity is turned off, they move back into a random pattern and block light.

While "smart glass" technologies promise to make huge contributions to efficiency, they are poised to have a tremendous impact architecturally on facade design. Most research focuses on the impact of switchable glazing on interiors because the goal is to control daylighting and heat gain. But what about the effect on a building's exterior, especially on the rhythm of fenestration, the architectural scale, and proportion? Switchability will make these elements fluid and certainly change perception.

Because the use of "smart glass" is not yet widespread, the impact on design has not begun to receive much investigation. However, an experiment in the area of adaptive building envelopes is under way at structural engineer and professor Werner Sobek's Laboratory at the Institute for Lightweight Structures and Conceptual Design at the University of Stuttgart, Germany. Of particular interest is a project called R129. "The goal of this project is to create a structure that will give the inhabitants direct contact with the surrounding nature, but still protect them from the elements," explains Sobek engineer, Frank Heinlein.

The building envelope is to be made of the switchable glass lites, plus a very thin layer of Plexiglas that provides antiscratch protection and has a low-E coating. These switchable lites consist of various layers, including an electrochromic foil. The foil allows the entire envelope to be darkened or made completely opaque, either in sections or as a whole. Adaptability is mainly achieved by means of the liquid crystal embedded within the glass panes, two polarization filters, and transparent electrodes. Different from other switchable-glazing product developments, this patent-pending technology allows light transmission to be varied, colorless, and quick to change.

The structural frame is fabricated from carbon box sections. The foundation is a carbon "raft," which carries a radiant-heated floor, HVAC equipment, storage, and IT functions. There are no fixed interior partitions or walls between the various functional areas. A central nonstationary module houses bathroom and kitchen installations.

The biggest concern at the moment in all R&D is durability. NREL has been testing electrochromic devices in accordance with ASTM standard E-2141 (Standard Test Methods for Assessing the Durability of Absorptive Electrochromic Coatings on Sealed Insulating Glass Units). The lab reports that at least one manufacturer has produced a ceramic, thin-film electrochromic device that has shown excellent durability under test conditions.

According to ToolBase Services (toolbase.org), the housing industry's resource for technical information about building products, materials, and new technologies, the cost of electrochromic windows can be from two to three times more than a standard window. Comparing the two is not particularly useful, though, because the equation doesn't take into account the energy savings from electrochromic insulated glass units. If electrochromic devices perform better, then a building can be equipped with smaller, and therefore less expensive, HVAC systems. At any rate, costs are expected to decrease significantly when manufacturing techniques improve and sales increase. Meanwhile, manufacturers are fine-tuning their control systems and exploring other means of powering the "smart glass." ■

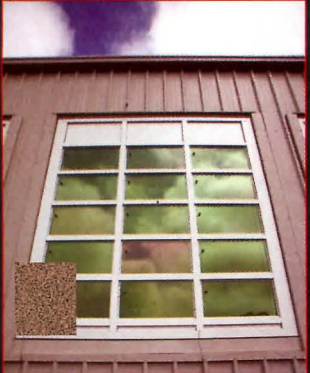

Scientists at LBNL are studying switchable-mirror technology. Electrochromic windows (above and left) are in various stages of dimming. The metal-hydride IGU (below right) has fewer layers than the conventional electrochromic IGU (below left), making the former more transparent and less expensive. A sample of a switchable mirror (bottom) shows one half of the window reflective, the other transparent.

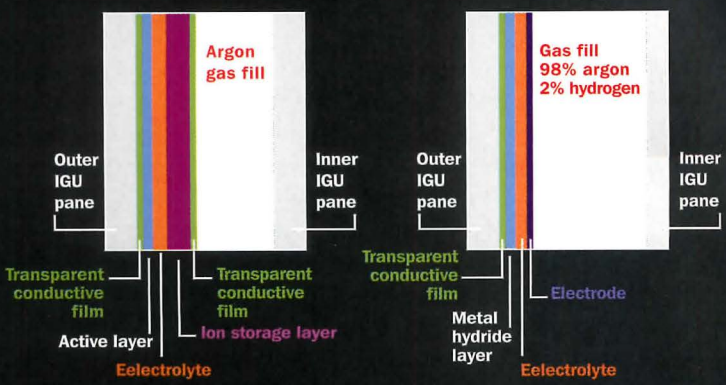



# Design Flexibility is Looking U.

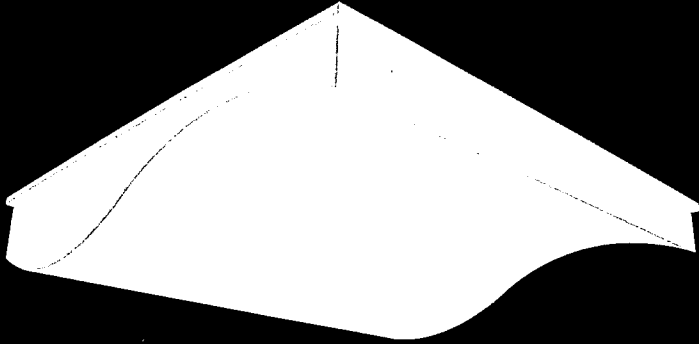

24" Wave Ceiling Panel

## Introducing Lightweight Panels That Create Stunning Ceilings

Nearwood brand ceiling panels are three-dimensional, Class A Fire-rated and fit into any standard suspension system, allowing full ceiling accessibility. Panels are offered in a variety of designs, in varying depths. Mix and match panels to provide random patterns and dimensional variety: creating a unique architectural appearance to ceiling spaces.

If you are imagining a custom design, call us and we'll make it a reality. We place your **IMAGINATION ABOVE ALL.**

- Class A Fire-rated
- Lightweight
- Very simple to install
- Fits 2' x 2' suspension systems
- Full ceiling accessibility

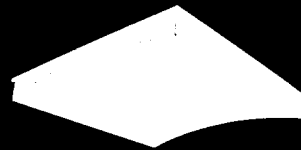

24" Concave Ceiling Panel



24" Convex Ceiling Panel



24" Ramp Ceiling Panel Up

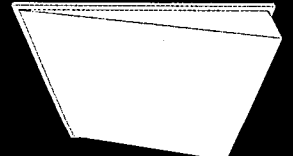

24" Ramp Ceiling Panel Down



NEARWOOD.COM

**NEARWOOD**  
ARCHITECTURAL ELEMENTS  
AN M-BOSS, INC. COMPANY

For more information  
call TOLL FREE: 877-296-2677  
or visit us at: <http://www.nearwood.com>  
Use promo code: ARR-1207 when contacting us.

CIRCLE 44 ON READER SERVICE CARD OR GO  
TO [ARCHRECORD.CONSTRUCTION.COM/PRODUCTS/](http://ARCHRECORD.CONSTRUCTION.COM/PRODUCTS/)



# Technicalities

## Chuck Hoberman wants buildings to change

By Nina Rappaport

Chuck Hoberman has a vision of Buckminster Fuller. As the New York-based artist, mechanical engineer, and product designer expands his projects to large-scale architecture, he is integrating his mechanized elements to develop a new strain of sustainable and flexible structures that conceptually relate to what the late Fuller had imagined, but never realized, decades before. Often starting with the simplest of ideas, such as the mechanism of a scissors, Hoberman amplifies operability and motion by connecting a series of hinged units to playfully form what he calls the Hoberman Sphere. In 2002, he increased the scale of the sphere into a dynamic, fan-shaped proscenium for the stage show for the Winter Olympics in Salt Lake City.

Of course, Hoberman, who presented his work at RECORD's 2007 Innovation Conference in New York, is not the only designer interested in mechanizing architecture. Critics such as Martin Pawley have envisioned flexible buildings outfitted with robotics. In 1987, Jean Nouvel famously tried—and failed—to do this at the Arab Institute in Paris. But it seems only NASA engineers have truly achieved the goal, having designed compact structures that can arrive on Mars to then unfold as instant habitats. For Hoberman, nature's transformations inspire his new designs for dynamic screens, window apertures, and awnings, at the scale of architecture in integrated systems.

Among current projects with Foster + Partners in London, Hoberman is collaborating on three 4,500-square-foot plazas for the Aldar Central Market, in Abu Dhabi. The project is like a modern interpretation of a souk. Hoberman is integrating square units of operable, anodized-aluminum extrusions that can expand within a gridded structure to limit sunlight and wind. Alternatively, when the elements retract, they disappear within the structure, opening up the roof to sunlight and breezes. When in various stages of closed or open, the coffers make a play of shadow and light similar to an Islamic patterned array.

A second Foster collaboration is for shading devices housed beneath the glazed atria of two circular court buildings, the Regional Appeal Courts and the High Court of Justice, at the City of Justice, in Madrid, Spain. Inspired by leaves of trees, Hoberman designed perforated anodized aluminum units to create the effect of dappled sunlight, which also enhances the atria's spatial experience. The various hexagonal, triangular, or rhomboid cellular units retract by folding into narrow bundles that disappear into the atria's diagrid structure. The Regional Court contains a series of 121 units that measure 9-by-9-feet each. The eight perimeter atria have 168 units that are 7-by-11-feet each, while the High Court has 115 units 3½-by-13-feet each. Hoberman used a solar-gain diagram to locate the responsive units. Computer sensors will control the roof's response. As Hoberman emphasizes, "This formula creates an adaptive building and responds in real time. By having the building capable of changing, you also have a new typology of what architecture can be." Albeit belatedly, architects are finally catching up to what Fuller—whose death in 1983 will be commemorated in many ways in 2008—had always envisioned. ■

For this story and more continuing education, as well as links to sources, white papers, and products, go to [architecturalrecord.com/features/interviews](http://architecturalrecord.com/features/interviews).

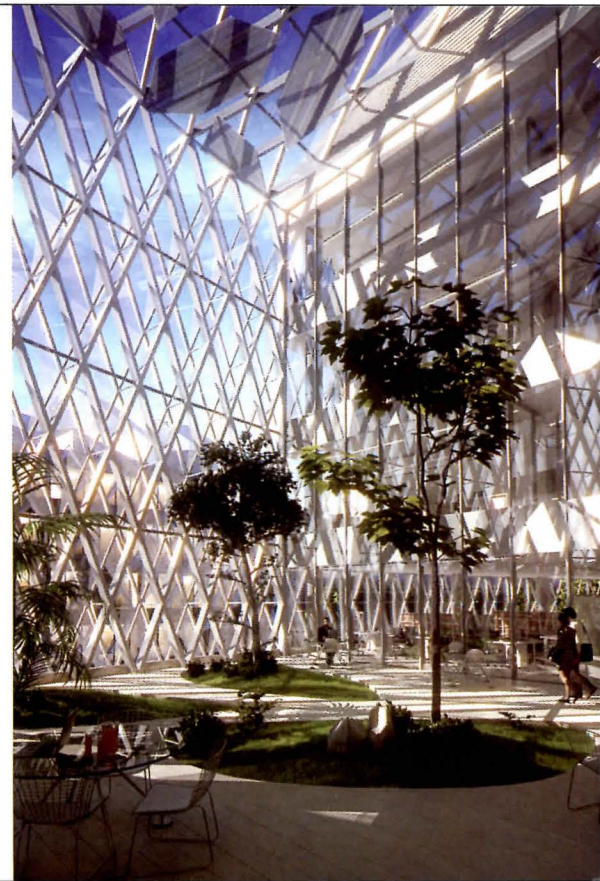
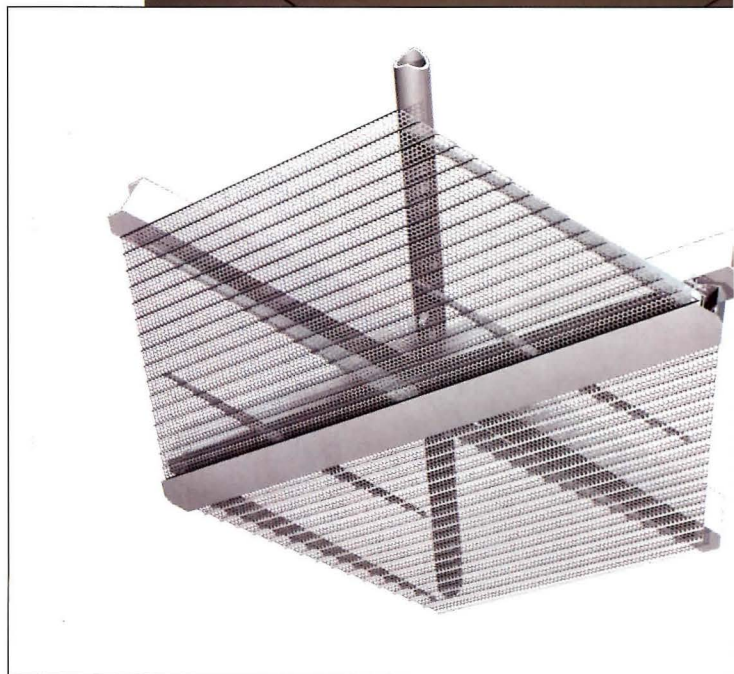
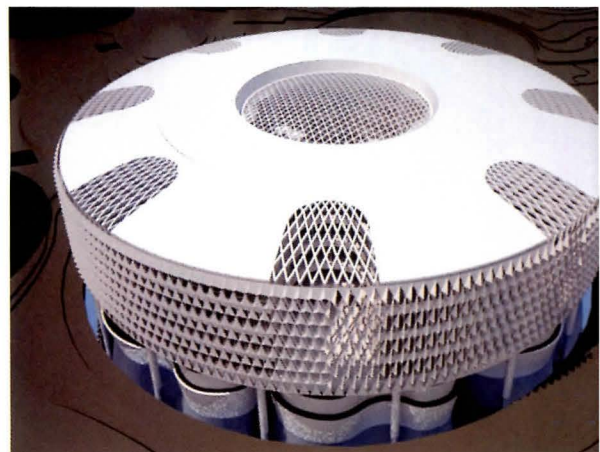

PHOTOGRAPHY: COURTESY FOSTER+PARTNERS (TOP AND BOTTOM AND OPPOSITE, TOP); COURTESY HOBERMAN ASSOCIATES (MIDDLE AND OPPOSITE, BOTTOM)



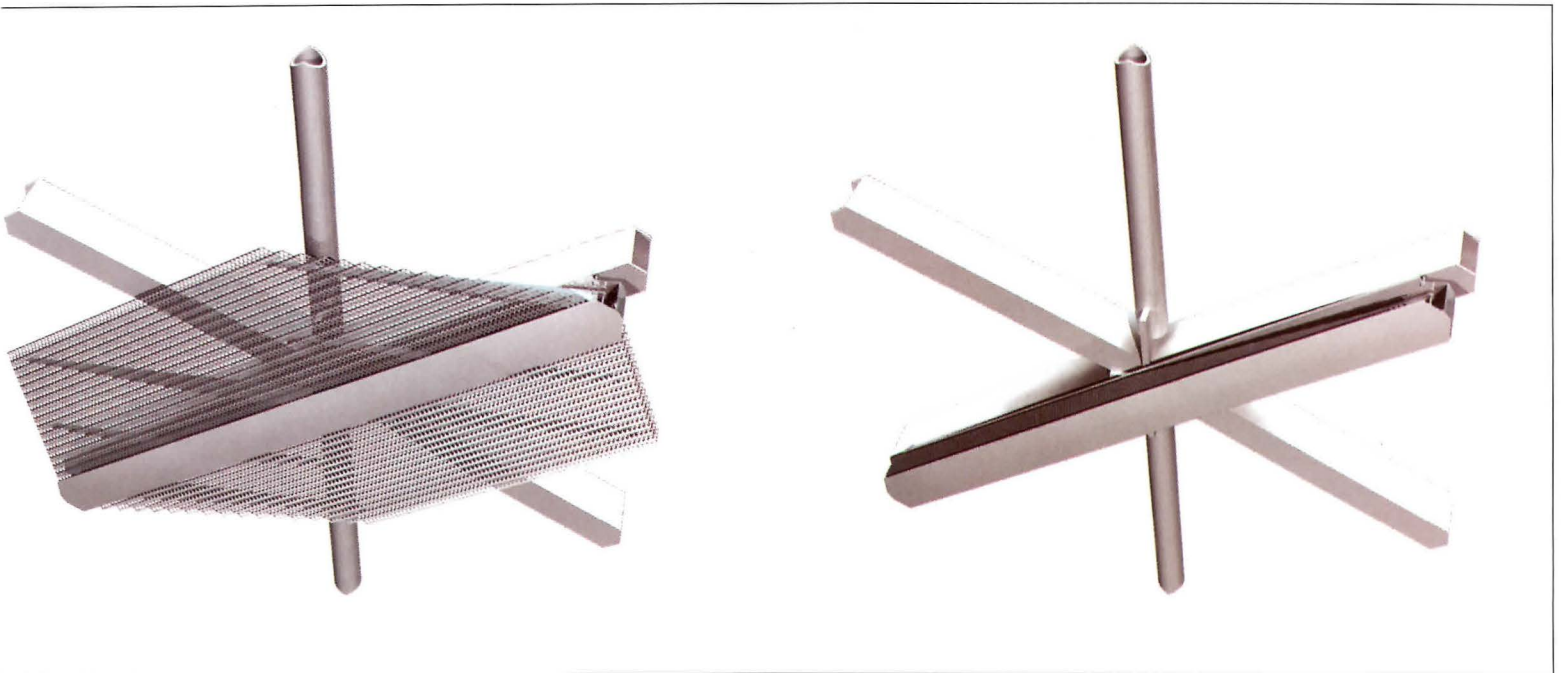

Hoberman Associates' collaboration with Foster + Partners focuses on sunshading devices. For the Aldar Central Market in Abu Dhabi (top three), anodized aluminum coffers will shift to block out sun and provide variable insulation depending on exterior conditions. At the City of Justice in Madrid, cellular shading units (above three) respond to a variety of geometrical configurations to shade atria when not concealed in the structure (opposite, top and bottom).

For the 2002 Winter Olympics in Salt Lake City, Hoberman Associates created a transformable "curtain," based on the Hoberman Sphere, for the outdoor stage used for medal ceremonies each evening.

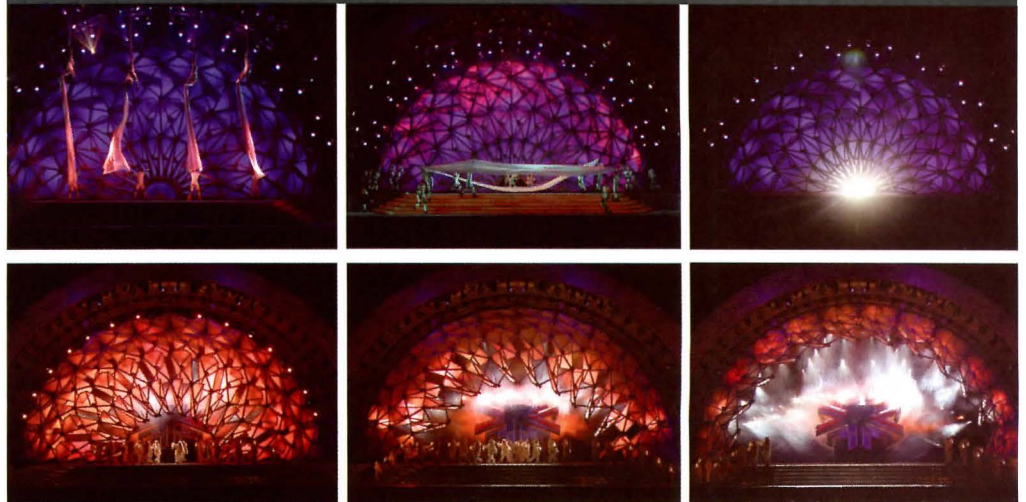





**Lamar Construction Company, Hudsonville, Michigan** For this small corporate headquarters outside of Grand Rapids, Integrated Architecture developed a 100-foot-long cantilever to lend the project presence from a nearby highway. The client also wanted to highlight its technical expertise through an ambitiously designed and constructed building.

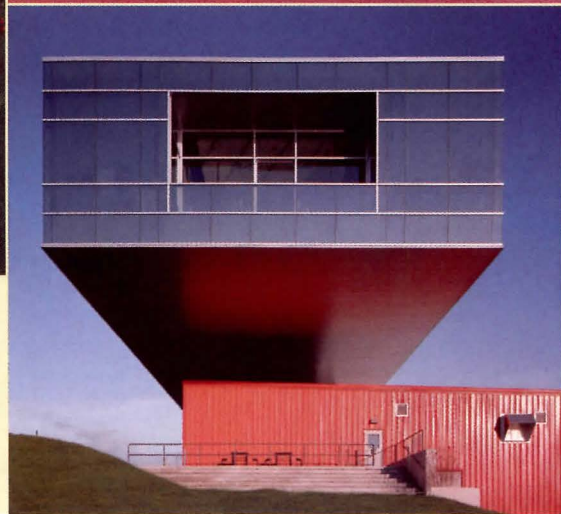

# Hanging Loose

By Russell Fortmeyer

Perhaps the most famous cantilever in America is one of the shortest: Frank Lloyd Wright's 1935 design for the exterior concrete terraces at Fallingwater, the longest of which extends a mere 15 feet to hover over the rush of Pennsylvania's Bear Run stream. Much has been made of the ongoing structural repairs the cantilevers have needed since they were built, but there has never been a question about preserving them.

A good cantilever can make or break a project. Writing in *Space, Time and Architecture*, Sigfried Giedion saw in Wright's extensive use of the cantilever a revolution in design, where space becomes an "essential part of the structure, molded as an inseparable part of it." Cantilevers found widespread favor in the development of Modern architecture in the last century. Mies van der Rohe used them to extend his "universal space" and to further dematerialize the field of vision in his projects. Architects who practiced certain strains of Modernism—think of the hanging corners at Hugh Stubbins's 1977 Citicorp Center in New York—preferred to disrupt, sometimes unintentionally, architectural stability with the cantilever.

Mega-projects with mega-budgets can more readily reach for these spectacular feats of engineering. But smaller projects, when done well, can still retain the power of the cantilever to draw our eye across its gravity-defying expanse. Wright used cantilevers two ways—for over-

hangs and habitable space—which is how we can think of three new projects completed in 2007 in Michigan, Japan, and Germany.

For the corporate offices of the Lamar Construction Company, located outside of Grand Rapids, Integrated Architecture designed a 52-foot-wide and 100-foot-long cantilever for the building's second floor. Michael Corby, AIA, a principal with Grand Rapids-based Integrated Architecture, says his office had never attempted a cantilevered design such as this. "We used a temporary scaffolding to build the trusses in the air," Corby says. "We then pulled the scaffolding away and the steel just hovered there," he says. The building has two volumes separated by a 16-foot gap—a lower, pre-engineered, orange (the company's signature color) steel box for storage and offices, and the cantilevered glass box for offices and a dining area. The interior of the primary cantilever is defined by the two 16-foot-deep trusses, each of which arrived on-site in three pieces. The trusses, spaced 26 feet apart, were also painted orange. A secondary cantilever extends outward to the edge of the box, perpendicular to the trusses.

Paul Dannels, AIA, a principal with Ann Arbor-based Structural Design Incorporated, designed the building's structural system and considers the cantilever a low-tech solution. "You really just have to buy into the size and scale of the trusses," he says. The trusses tie into a secondary



**K Clinic, Nara, Japan** Akira Yoneda's Tokyo firm, Architecton, designed this 55-foot-long cantilever to hold a doctor's private study. Yoneda notes that such structural feats are getting rarer in Japan as designers have experienced increased liability due to structural engineering errors.



## MODERN ARCHITECTS HAVE LONG BEEN FASCINATED BY CANTILEVERS, BOTH FOR THE STRUCTURAL BRAVADO, AS WELL AS THE LACK OF IMPEDIMENTS TO A GOOD VIEW. BUT IS THERE SOMETHING DEEPER TO THE REPEATED USE OF THIS STRUCTURAL FEAT?

steel structure contained within a poured-in-place concrete shaft that includes an elevator and a staircase. That steel structure is anchored in a 6-foot-deep subgrade concrete footing, 62 feet wide and 90 feet long. The length of the footing, which extends underground along the horizontal axis of the cantilever, counteracts the tendency of the cantilever to want to pull the building over. All cantilevers, from simple to complex, have to be designed to resist the moment of this force.

Additionally, a 4-inch camber was designed into the unsupported end of the volume. Corby says once they pulled away scaffolding, the structure dropped  $\frac{3}{4}$  inch. The remainder,  $3\frac{3}{4}$  inches, takes into account other loads. Since the building is located near Lake Michigan, it experiences a high wind load. "It's unusual to have a building that is so influenced by twist, or torsion of the concrete shaft," Dannels says. "As the wind hits the building, it wants to turn like a weather vane." The steel frame in the concrete shaft resists that movement.

Where the Michigan project is more of a conventional structural cantilever, the new K Clinic in the Japanese city of Nara, just outside of Osaka, takes a minimalist approach to integrate the architecture fully into the structure. The Tokyo architect and engineer Akira Yoneda, whose firm, Architecton, was chosen for RECORD's 2004 Vanguard, had less program space to incorporate for his client, a dermatologist who had briefly

studied architecture while in college. The doctor asked Yoneda to design a building that would make a statement along the city's main street. The clinic is located in a ground-level structure, while the cantilever is reserved for the doctor's private study. The opening at the end reveals a view of distant mountains.

The nearly 55-foot-long cantilevered volume is a tube structure formed by steel plates and a deck. Yoneda treated the surface of the plates with a ceramic insulating paint to improve the thermal properties. He wanted the building to recall the neighborhood's previous topography, which was defined by a gently sloping hill. For Yoneda, the linear shape of the building "reflects the inclination of the street and tried to reify the missing profile of the land." He considers the cantilever a continuation of a Modernist project of dialectical investigation—physical and phenomenal, gravitational and antigravitational, materialization and dematerialization, and anchoring and drifting. "I think a cantilever is one of those topics that is still worth considering," Yoneda says.

Unoccupied cantilevers typically present fewer structural challenges because of smaller loads and fewer erratic live loads, such as people. Stuttgart, Germany-based Barkow Leibinger Architects collaborated with structural engineers at Werner Sobek's Stuttgart offices to design a gatehouse that features such a cantilever for the local campus of Trumpf, a company



**Trumpf Gatehouse, Stuttgart, Germany** Barkow Leibinger Architects developed a slender, internally illuminated cantilever for the “front door” of a manufacturing complex. The design highlights the client’s expertise at laser-cut production techniques, as well as Germany’s tradition of precise engineering.



manufacturing production equipment and medical technology. As the gatehouse would be the front door to Trumpf’s manufacturing campus, it was important that the typically banal building type make more of a statement.

Barkow Leibinger and Sobek both had designed other buildings on the campus and wanted to seize on Trumpf’s particular expertise—its precise laser-cut manufacturing capabilities—as the aesthetic motivation for the project. Frank Leibinger views the project, which he describes as “muscular,” as partly revisiting the sheet-metal construction studies of Jean Prouvé, the late French architect who translated industrial manufacturing techniques into elegant, aluminum kit-of-parts buildings. “We want to take digital technologies and use them on these projects of mass-customization, modulation, and repetition,” Leibinger says, explaining why they developed a rather complex solution to a simple program.

The gatehouse consists of a glass-enclosed interior staff area with four steel columns, clad in brushed stainless steel, supporting the roof’s 63-foot cantilever. A smaller 8½-foot cantilever extends on both sides of the columns, perpendicular to the main cantilever axis. The 2-foot-thick roof consists of 17 hollow box girders with a flange width that varies from thick at the columns to thin at the unsupported end, which has a camber of 1½ feet. The architects developed a zigzag pattern of steel-plate cross beams based on Sobek’s stress diagram. Thomas Winterstetter, the project’s struc-

tural engineer, says the zigzag is purely aesthetic, but the pattern also prevented shadows on the visible laser-cut triangular pattern of the LED-illuminated acrylic ceiling panels. The roof arrived on-site in six pieces, which were then bolted together before the entire piece could be lifted up by crane and secured to the columns. With minimal dead loads, the flat foundation amounts to a single footing that was thicker—3 feet—than the typically required 6 inches. The wind loads on the Trumpf gatehouse were minimal, but turbulent—since the building is so close to the ground—meaning the engineers did not need to consider heavy laminar wind shedding, which might have caused the roof to lift up and overturn.

So, why not simplify the matter and, through engineering expediency, add a column or two to the end of the roof? What made Wright, Mies, and many contemporary architects and engineers return to the cantilever again and again? Winterstetter, who admits to having only briefly considered this, refers to the Austrian architect Hans Hollein, who wrote about early forms of shelter in essays in the 1960s, such as *Plastic Space*. Hollein describes the human need, rooted in our cave- and tree-dwelling past, to move through three-dimensional space, engaging it without obstruction. “You have this almost archaic feeling that there may be a predator following you,” Winterstetter says, “and you want nothing blocking your view.” In that light, you have to wonder why there aren’t more cantilevers. ■



# Tech Software Review

## Get virtually organized for the new year

### VectorWorks Architect 2008

Nemetschek North America's all-in-one VectorWorks Architect BIM platform was streamlined and rereleased in September. Among many of the standard bells and whistles, the software includes symbol libraries from manufacturers such as Herman Miller and Marvin Doors and Windows, as well as color palettes tied to Pantone, Benjamin Moore, and Sherwin-Williams. Available for Mac and Windows. [www.nemetschek.net](http://www.nemetschek.net)

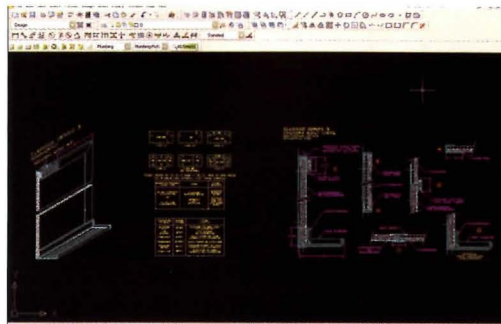
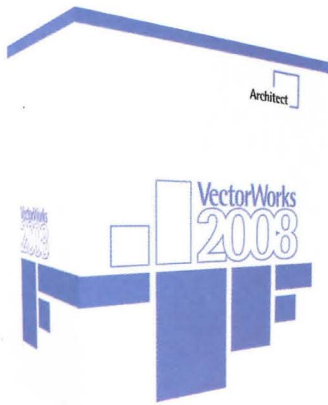

### Architectural Data Systems

ADS provides an online link between manufacturer's details and construction drawings, making it simple for an architect to import products that conform to specifications right into a project's CAD platform. With more than 100,000 products representing more than 1,000 manufacturers, searching is free, but producing a schedule requires a fee. Architects can search based on LEED points, too. The program is compatible with Autodesk and Bentley programs, among others. [www.architecturaldatasystems.com](http://www.architecturaldatasystems.com)

### Adobe Creative Suite 3

Adobe keeps rolling out new releases across its entire product platform, with the latest being the Creative Suite 3 for Design and Web clients. The premium version of the software includes the latest releases of InDesign, Photoshop, Illustrator, Flash, Dreamweaver, and Acrobat applications—everything the busy architect needs to make snappy pictures and presentations that are print- and Web-ready. Available for Mac and Windows. [www.adobe.com](http://www.adobe.com)

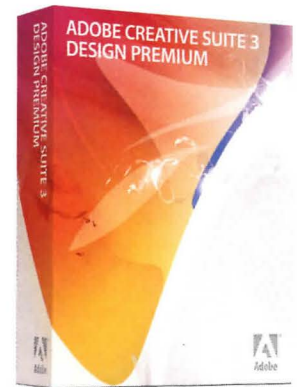

### TurboCAD Pro 14

IMSI Design's TurboCAD Pro release 14 debuted in May and includes a plug-in for Google's SketchUp, as well as a feature that makes producing photorealistic renderings easier. The BIM application program also reads files from a range of other CAD platforms, including Autodesk's AutoCAD 2008, making it ideal for smaller firms negotiating a range of file types. Available for Mac and Windows. [www.imsidesign.com](http://www.imsidesign.com)

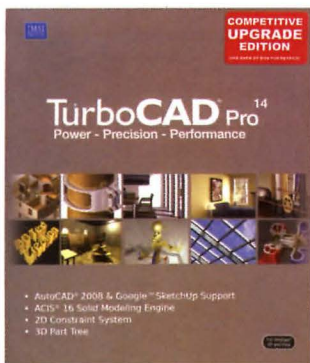

### ArchiCAD 11

Graphisoft's virtual building model software, ArchiCAD, is the first release in the company's move to annual releases for its BIM product. Although it includes many enhancements, two features are aimed toward improving coordination: Virtual Trace, which allows live coordination between all model views, and Visual Compare, which makes finding differences between model and drawing views easier. Available for Mac and Windows. [www.graphisoft.com](http://www.graphisoft.com)

### formZ 6.5

AutoDesSys's formZ has long been an industry standard for modeling and rendering three-dimensional architectural space, but the new release includes RenderZone Plus. This rendering engine produces the program's reliably high-quality results, but in significantly less time. It features advanced lighting simulations, including direct ambient and indirect conditions. Available for Mac and Windows. [www.formz.com](http://www.formz.com)

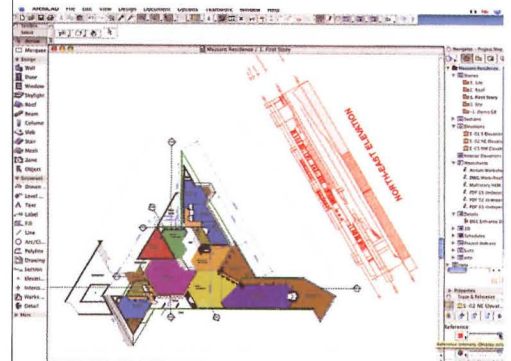





## What's on your mind?

From historical preservation to justice architecture, the AIA's Knowledge Communities connect you with like-minded architects. Use your head—go to [www.aia.org/knowledge](http://www.aia.org/knowledge) and join today. Find the Knowledge Community that's right for you and network with architects who share your interests.

Whatever you're interested in, the American Institute of Architects has a Knowledge Community for you.

AIA Knowledge Communities 



To receive AIA/CES credit, you are required to read the additional online text, which can be found at [continuingeducation.construction.com](http://continuingeducation.construction.com). The quiz questions below include information from this online reading.

Program title: "Hardwoods for High-Traffic Areas" (12/07, page 189). AIA/CES Credit: This article will earn you one AIA/CES LU hour of health, safety, and welfare credit. (Valid for credit through December 2009). **Directions:** Refer to the Learning Objectives for this program. Select one answer for each question in the exam and fill in the box by the appropriate letter. A minimum score of 80% is required to earn credit. **To take this test online, go to [continuingeducation.construction.com](http://continuingeducation.construction.com)**

**Learning Objectives**

After reading this article, you should be able to:

- Evaluate the suitability of specifying American hardwoods in high-traffic settings
- Explain how life-cycle thinking influences green building products selection
- Consider appropriate finishes for hardwoods in different settings
- Discuss economic considerations for hardwood maintenance and care

**Questions**

1. The Janka Rating System measures:

- a. the quality of wood.
- b. the relative hardness of wood.
- c. character markings.
- d. manufacturing marks.

2. Engineered wood is:

- a. not dimensionally stable.
- b. more expensive than solid wood.
- c. affected less by changes in humidity than solid wood.
- d. cut in 6-inch by 6-inch blocks.

3. White oak:

- a. is impervious to liquids.
- b. is a dark sapwood.
- c. contains brown pith flecks.
- d. can also occur as "curly" or "fiddleback."

4. Beyond initial costs and installation, hardwoods:

- a. slightly exceed the life cycle cost of vinyl.
- b. are very expensive to refinish.
- c. are less expensive overall than other alternatives.
- d. are equal in cost to other alternatives.

5. The water-based urethane finishes:

- a. are apt to turn yellow.
- b. accelerate color changes.
- c. dry quickly.
- d. are the most commonly used floor finishes.

6. A type of finish extremely resistant to abrasion and moisture is:

- a. oil-based polyurethane.
- b. conversion varnish.
- c. aluminum oxide.
- d. acrylic impregnated.

7. Manufacturers say factory-applied finishes are more consistent and durable because they:

- a. are applied under strict controls.
- b. can have conversion varnish applied.
- c. are dust free.
- d. contain acrylics.

8. Finishing floors on site requires more time and skill than installing factory-finished materials.

- a. True
- b. False

9. The main damage to a wood floor comes from:

- a. sunlight.
- b. high traffic.
- c. debris.
- d. scuff marks.

10. Compared to 50 years ago, the volume of hardwood in the United States today is:

- a. the same.
- b. 20 percent less.
- c. 50 percent less.
- d. 90 percent larger.

Last Name \_\_\_\_\_ First Name \_\_\_\_\_

Job Title \_\_\_\_\_

Firm Name \_\_\_\_\_

Address \_\_\_\_\_

City \_\_\_\_\_ State \_\_\_\_\_ Zip \_\_\_\_\_

Tel. \_\_\_\_\_ Fax \_\_\_\_\_

E-mail \_\_\_\_\_

AIA ID Number: \_\_\_\_\_ Completion date (M/D/Y): \_\_\_\_\_

Check one:  \$10 Payment enclosed. (Make check payable to McGraw-Hill Construction and mail to: Continuing Education Certificate, PO Box 5753, Harlan, IA 51593-1253.) For customer service, call 877/876-8093.

Charge:  Visa  Mastercard  American Express

Card# \_\_\_\_\_

Signature \_\_\_\_\_ Exp. Date \_\_\_\_\_

**Check below:**

To register for AIA/CES credits: Answer the test questions and send the completed form with questions answered to address at left, or fax to 888/385-1428.

For certificate of completion: As required by certain states, answer test questions, fill out form, and mail to address at left, or fax to 888/385-1428. Your test will be scored. Those who pass with a score of 80% or higher will receive a certificate of completion.

Material resources used: Article: This article addresses issues concerning health and safety.

I hereby certify that the above information is true and accurate to the best of my knowledge and that I have complied with the AIA Continuing Education Guidelines for the reported period.

Signature \_\_\_\_\_ Date \_\_\_\_\_

127SPONB



The Hardwood Council serves architects, designers and builders by providing useful information about North American hardwoods in sustainable design and building. As an independent, nonprofit organization, the Council advances better understanding of hardwood flooring, furniture, cabinetry and millwork, without bias toward specific products or manufacturers. For more information about The Hardwood Council, and North American hardwoods, please visit [www.hardwoodcouncil.com](http://www.hardwoodcouncil.com)



# Product Reports 2007

- 196 Editors' Picks
- 199 Top Ten Green Products
- 203 Concrete & Masonry
- 205 Metals, Wood, Plastics & Composites
- 211 Thermal & Moisture Protection
- 215 Openings
- 220 Finishes
- 225 Specialties
- 227 Equipment
- 228 Furnishings & Exterior Improvements
- 231 Conveying Systems
- 232 Plumbing, HVAC & Special Construction
- 239 Electrical

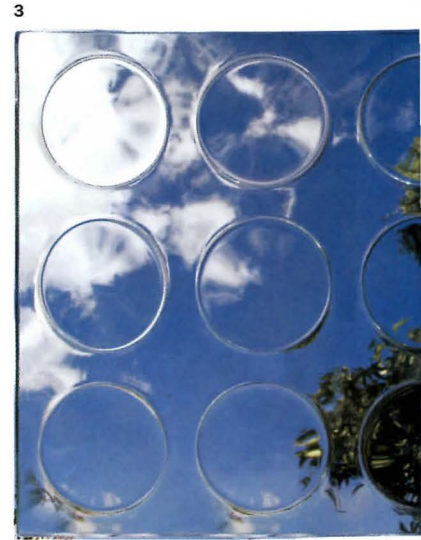

ARCHITECTURAL RECORD'S 35TH ANNUAL PRODUCT REPORTS PRESENTS MORE THAN 300 OF THE YEAR'S MOST INNOVATIVE NEW BUILDING PRODUCTS SELECTED BY A JURY OF ARCHITECTS AND DESIGNERS

**W**hat exactly constitutes an *innovative* building product? Each year, on behalf of our readership, ARCHITECTURAL RECORD tries to define this term by assembling a group of product experts—including architects, lighting designers, and product designers—who are given the task of delving through hundreds of submissions to find products that push the envelope of what is typically expected from offerings in that category. It is important to note that rewarding innovation merely for its own sake was not the goal of the jury. “Not all innovations are good innovations,” explains juror Charles Renfro, AIA. For Renfro, “developing materials that masquerade as other materials always seems like the wrong direction for innovation.” Juror Eric Bunge, AIA, was drawn to products that are “beautiful with a purpose,” such as a 3D felt-wool wall covering that improves the acoustics of a space. He was also swayed by products in general “that embrace the use of technology together with something performative.”

This year, our jury was impressed by products intended to

help reduce waste, such as stone masonry designed and precision cut using CAD/CAM, or a residential carbonated-water dispenser that eliminates unnecessary packaging. Overall, verifiably green products had a stronger presence in the submissions this year, including water-conserving plumbing fixtures, a concrete block made of recycled materials, and glass made from 100 percent recycled content from a manufacturer who, according to one juror, “sensed an opportunity and pushed on it.” Also of interest to the jury: product hybrids that are difficult to classify, such as a clever “rug” developed by a young German designer that morphs from a floor covering to a privacy screen to a seat.

Thanks are due to all of the building product manufacturers who submitted this year and to our team of jurors. We hope that the following pages serve as a resource that you and your practice can refer to again and again in the coming year. *Rita Catinella Orrell*

For more information, circle item numbers on Reader Service Card or go to [architecturalrecord.com/products/](http://architecturalrecord.com/products/).



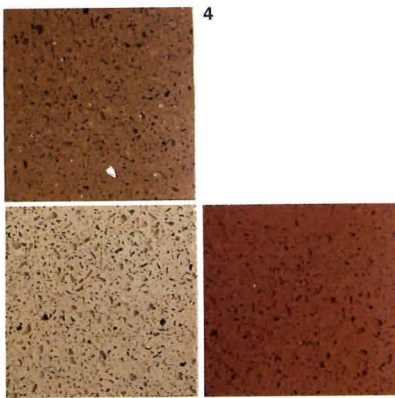

4



5

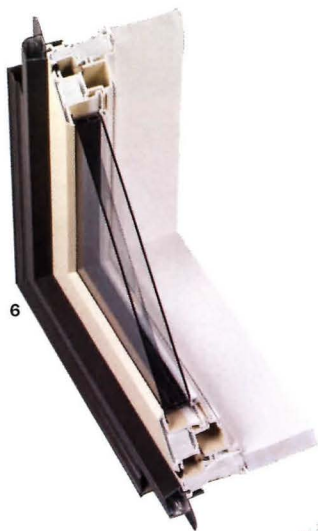

6

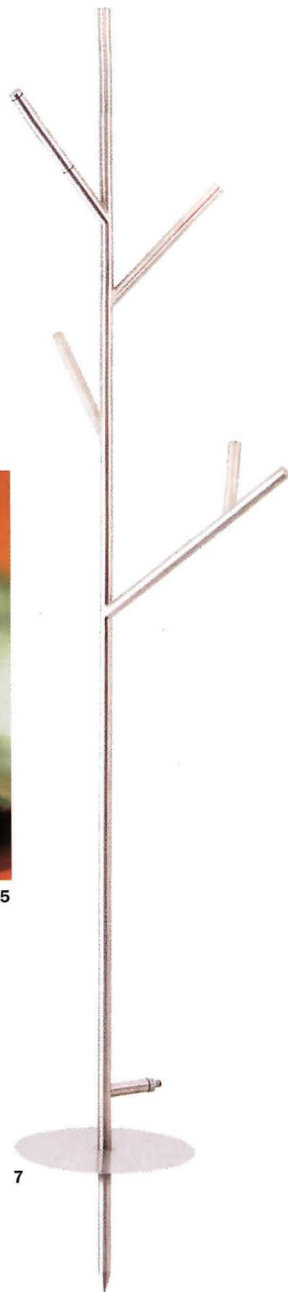

7



8



## Our 2007 Product Reports Jury

All jurors are based in New York City (standing, left to right): **Leslie Gill**, educated at New York's Copper Union for the Advancement of Science and Art, founded her own practice, Leslie Gill Architect, in 1995. Notable projects include Elektra Entertainment's corporate headquarters in Manhattan; programming and master planning for Warner Bros. Records, Los Angeles; and residences throughout the Eastern seaboard. **Eric Bunge**, AIA, is a partner with Mimi Hoang at nARCHITECTS, founded in 1999. Bunge is the graduate thesis director at Parsons The New School of Design in New York, and has taught at R.I.S.D.; Barnard and Columbia Colleges; the University of California, Berkeley; and the University of Toronto. He won the 2005 Canadian Professional Rome Prize. **K. Brett Malak** is director of lighting design for Cosentini Lighting Design. Prior to joining Cosentini in 2004, she worked in lighting as well as product and industrial design. Her project experience includes the Time Warner Headquarters in New York City, the American Medical Association in Washington, D.C., and The Visionaire, a LEED Platinum building in Battery Park City, New York. **Jacob Alspector** is the principal of his eponymous full-service architecture and interiors firm with expertise in public and academic research libraries; educational and cultural buildings; and modern and historic landmark restorations, renovations, and expansions. Current work includes the new, 200,000-square-foot Digital Learning Center at Utah Valley State College in Orem and the conceptual master plan and design for the John Cotton Dana Library at Rutgers University in New Jersey. **Charles Renfro**, AIA, joined Diller+Scofidio in 1997 and was promoted to partner at Diller Scofidio + Renfro in 2004. As collaborator with Diller+Scofidio, he served as project leader on the Brasserie restaurant in New York, the master plan for the city's Brooklyn Academy of Music (with Rem Koolhaas/OMA), the Boston Institute of Contemporary Art, and the redesign and expansion of the Juilliard School and Alice Tully Hall at Lincoln Center in New York, among other projects. **Christian P. Arkay-Leliever** (seated) is director of products for Rockwell Architecture, Planning and Design, where his projects include designs for Maya Romanoff Wallcoverings, Leucos, and DuPont Corian. Before joining Rockwell in 2006, he worked as an associate director of strategic innovation for Skidmore, Owings & Merrill in New York City.

1. Skygarden lamp, Flos (Electrical) 2. Drops tile collection, Viva Ceramica (Finishes) 3. Circles Convex glass, Nathan Allan Glass Studios (Openings) 4. Eco-X, Meld USA (Concrete & Masonry) 5. EnkaRetain & Drain matting, Colbond (Thermal & Moisture Protection) 6. Alpenglass fiberglass window, Alpen Energy Group (Top Ten Green Products) 7. Under the Tree garden shower, Conmoto (Plumbing, HVAC & Special Construction) 8. Ogee curtain fabric, Kova Textiles (Furnishings & Exterior Improvements)





# Editors' Picks

There are a multitude of reasons why a product grabs the attention of our editors. Sometimes it's the ability to wear two seemingly contradictory hats at the same time, such as a durable solid surface that can be translucent; other times, it's a response to an obvious need in the market, such as a recycling program for vinyl wall coverings. —R.C.O.

The first recycling program for vinyl wall coverings, **Second-Look** reclaims vinyl wall covering made by any manufacturer and recycles it into new wall-covering designs. LSI works with architects, designers, facility managers, and contractors to reclaim used vinyl wall covering from renovation projects; the reclaimed material is then recycled in three collections, offering 160 selections with 20 percent recycled content, including 10 percent postconsumer. LSI Wallcovering, Louisville. [www.secondlookwc.com](http://www.secondlookwc.com) **CIRCLE 200**



The zero-post, **90-degree Exterior Folding Door System** allows designers to open up two wall spans in a room with a single product. Beveled door edges and double weatherstrips seal the unit against the elements, even without a structural corner post. Applications range from high-end single-family homes and condos to commercial projects, such as hotels and restaurants. Jeld-Wen Windows & Doors, Klamath Falls, Ore. [www.jeld-wen.com](http://www.jeld-wen.com) **CIRCLE 201**



DuPont Corian's **Illumination Series** allows up to three times as much light to pass through than other Corian colors. Consisting of Arctic Ice and Glacier Ice, the Series' translucency makes it an ideal choice for backlit designs, multi-sensory environments, and lighting fixtures. DuPont Corian recently became Greenguard Indoor Air Quality certified and received the Greenguard for Children & Schools Certification. DuPont Surfaces, Wilmington, Del. [www.countertops.dupont.com](http://www.countertops.dupont.com) **CIRCLE 202**

The limited edition **Reveal lamp** creates the impression of sunlight shining through a window and onto an interior wall. The U.L.-listed fixture can be placed on a shelf or mounted directly on a wall or ceiling. Multiplane analog images create a sense of depth in the cast image, and air currents through the projector simulate organic, nonrepeating movement in the trees. Adam Frank Inc., Brooklyn, N.Y. [www.adamfrank.com](http://www.adamfrank.com) **CIRCLE 203**



**SmartScan**, the industry's first residential biometrically accessible dead-bolt door-lock system, was introduced at this year's Builders' Show. Programmable with up to 50 user fingerprints, the lock can be controlled by swiping a valid, live fingerprint across the sensor, eliminating the need for a key or key code. Kwikset, Lake Forest, Calif. [www.kwikset.com](http://www.kwikset.com) **CIRCLE 204**





First introduced in 2003, ThyssenKrupp's Twin elevator system offers two independent cabs running in one shaft. Twin has proven to be adaptable: The first two **panoramic Twin systems** in the world were recently installed in the Main Triangel building in Frankfurt, Germany, allowing the architects to maintain the light, open concept of the largely glass facade. ThyssenKrupp Elevator, Dallas. [www.thyssenkruppelevator.com](http://www.thyssenkruppelevator.com)

**CIRCLE 205**

**StumbleLight** is a motion-activated, LED night-guiding light designed to turn on when a hotel guest steps out of bed, preventing the need to turn on bright room lighting that could disrupt a full night's sleep. Upon detecting motion at night, StumbleLight instantly provides light at full intensity for 12 seconds and, if no motion is detected, will slowly fade from full intensity to off. Philips Lighting, Somerset, N.J. [www.us.philips.com](http://www.us.philips.com) **CIRCLE 208**

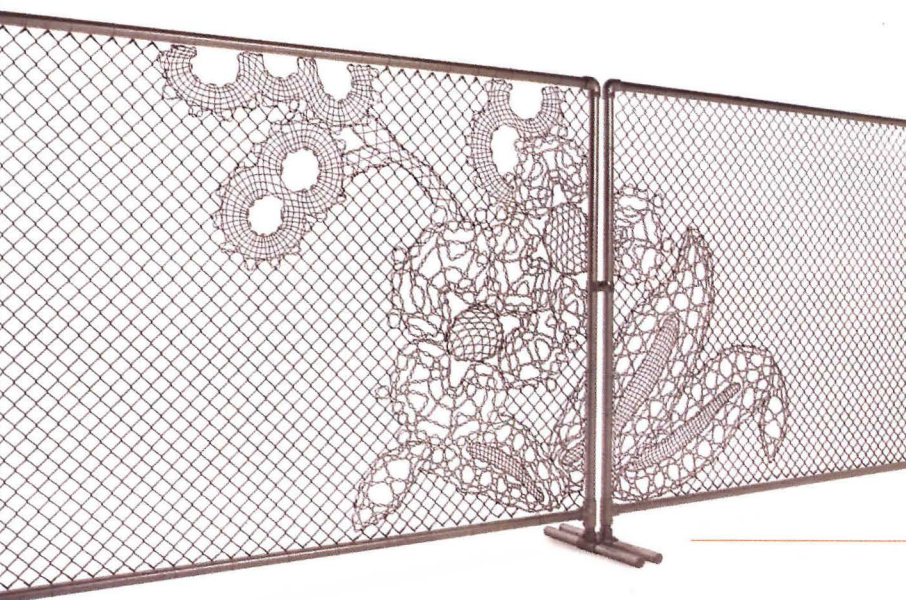

Designed by the young Dutch firm Demakersvan and produced by ID Fence in Bangalore, India, the patterns for **Lace Fence** are produced by hand for indoor or outdoor use with the same wire as machine-made industrial chain-link mesh. Designs can be created to help discourage climbers, hide or enhance surroundings, deal with harsh weather, or create a custom look. Demakersvan, Rotterdam. [www.demakersvan.com](http://www.demakersvan.com) **CIRCLE 209**

Dyson's touchless **Airblade** produces a 400-mph stream of clean air that acts like an invisible windshield wiper, wiping moisture from hands and leaving them dry in about 12 seconds. Airblade's HEPA filter removes more than 99.9 percent of bacteria from the air used to dry hands, and uses up to 80 percent less energy than traditional hand dryers. Dyson, Chicago. [www.dysonairblade.com](http://www.dysonairblade.com) **CIRCLE 206**



Grimshaw Architects developed the design for the new **New York City street furnishings** currently being installed by Cemusa throughout the city. Three-hundred-thirty newsstands, 3,300 glass-and-steel bus stops, and 20 automatic public toilets are planned. The structures are made from recyclable components, including high-resistance tempered-and-laminated glass and stainless steel. Cemusa, New York City. [www.cemusany.com](http://www.cemusany.com)

**CIRCLE 207**



Wood. Metal. Marble.  
Opaque. Translucent. Backlit.  
Countless possibilities that all  
end with **WOW**.  
Just imagine.

  
myriad™  
Wall Systems



[www.marlite.com](http://www.marlite.com)

 **Marlite**  
simply amazing

CIRCLE 56 ON READER SERVICE CARD OR GO TO [ARCHRECORD.CONSTRUCTION.COM/PRODUCTS/](http://ARCHRECORD.CONSTRUCTION.COM/PRODUCTS/)



# Top Ten Green Products

The 2007 Top Ten Green Building Products, announced by BuildingGreen at last month's GreenBuild show in Chicago, offer a variety of environmental benefits.

## Sunny solution

The Solmetric SunEye is a hand-held electronic device that measures solar shading and calculates solar access for solar installers and green builders. Its digital camera captures images of a site; users can then edit images by simulating removal of obstructions such as trees or structures. Solmetric, Bolinas, Calif.

[www.solmetric.com](http://www.solmetric.com) **CIRCLE 210**

## A window of performance

Alpen uses a combination of suspended low-E heat mirror films, low-E coatings on glass, low-iron glass that increases visible light transmittance, low-conductivity gas fill (including krypton and xenon), pultruded-fiberglass frames insulated in vacuum silica-aerogel packets, and low-conductivity glazing spacers, to provide the 1 $\frac{3}{8}$ " Alpenglass fiberglass windows with a range of properties for different needs. Alpen Energy Group, Boulder.

[www.alpeneg.com](http://www.alpeneg.com) **CIRCLE 211**

## Quietly green

Bosch's 800 Series SHE 98M model of Evolution Dishwashers is rated at 190 kWh per year of electricity consumption, an Energy Factor of 1.14, and a noise level of 42 dBA. BSH Home Appliance, Huntington Beach, Calif.

[www.boschappliances.com](http://www.boschappliances.com) **CIRCLE 212**

## No batteries needed

A company developed by Siemens, EnOcean has engineered radio-frequency communication to use  $\frac{1}{100}$  the usual power. Powered by harvested ambient energy, such as mechanical energy from operating a light switch, the controllers operate without batteries and reduce battery waste. EnOcean, Salt Lake City.

[www.enocean.com](http://www.enocean.com) **CIRCLE 213**

## Good, clean fun

Skyline Design's Greenplay furnishings for children are made with environmentally responsible and healthy materials and finishes, including postconsumer recycled plastic, sunflower hulls, and FSC-certified wood. Skyline Design also accepts outgrown Greenplay components for repurposing and donation. Skyline Design, Chicago.

[www.skydesign.com](http://www.skydesign.com) **CIRCLE 214**



210



211

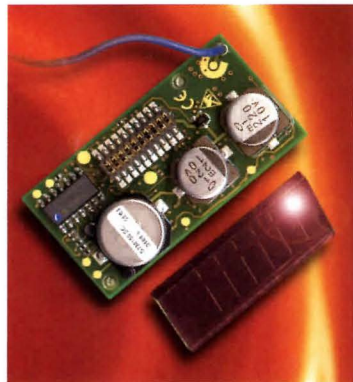

213

212

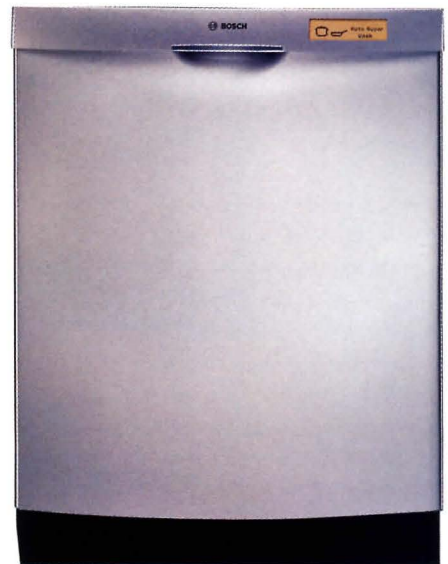

214



# Top Ten Green Products

Solar instrumentation • Fiberglass windows • Furniture • Residential appliances • Particleboard • Wall coverings • Interior lighting • Electrical cables • Urinals

## Above-par particleboard

FreeForm is a new FSC-certified particleboard produced without added urea-formaldehyde (a melamine-formaldehyde binder is used instead). Initial chamber testing has shown formaldehyde emissions to meet Phase I California Air Resources Board standards. The company hopes eventually to eliminate formaldehyde-based binders from its products. The Collins Companies, Portland, Ore. [www.collinswood.com](http://www.collinswood.com)

CIRCLE 215

## Off the wall

Milliken's 180 Walls is a highly permeable, woven wall covering for commercial applications made from 100 percent preconsumer recycled polyester. Its self-adhesive backing eliminates the need for paste. The product has received a Silver rating in McDonough Braungart Design Chemistry's Cradle to Cradle certification program; it's also less expensive than most fabric wall coverings. Milliken & Company, Spartanburg, S.C.

[www.180walls.com](http://www.180walls.com) CIRCLE 216

## Premium cable

LifeGuard is a line of low-smoke, near-zero-halogen electrical cables. The cable is primarily used in utility and industry applications but has also been used in hospitals and universities where toxic smoke from halogenated cable is of particular concern. Houston Wire & Cable Company, Houston. [www.houwire.com](http://www.houwire.com)

CIRCLE 217

## Downlighting's upside

LED Lighting Fixtures's LR6 downlight uses just under 11 watts to provide 650 lumens of light and a measured efficacy of 60 lumens per watt—better than most CFLs. The product is designed to produce a natural-looking, warm-white light and to fit standard 6" recessed cans. LED Lighting Fixtures, Morrisville, N.C. [www.lfinc.com](http://www.lfinc.com) CIRCLE 218

## High-efficiency, low water

Caroma's Cube<sup>3</sup> Ultra urinal flushes using just one pint of water. Its bowl optimizes low-water use and features a liquid-sensing automatic flush mechanism that prevents false flushes. Its high-gloss, vitreous china surface minimizes staining and improves sanitation and cleaning. Caroma USA, Hillsboro, Ore. [www.caromausa.com](http://www.caromausa.com) CIRCLE 219



215



216

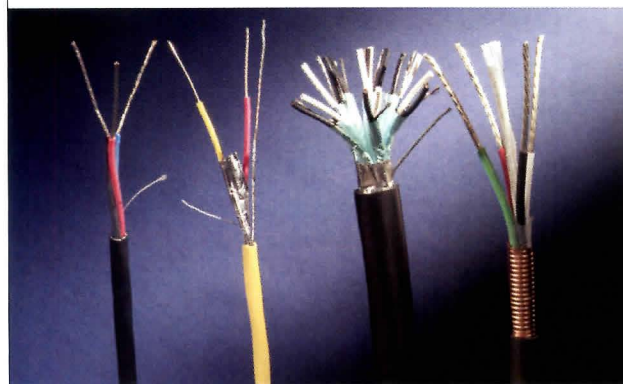

217

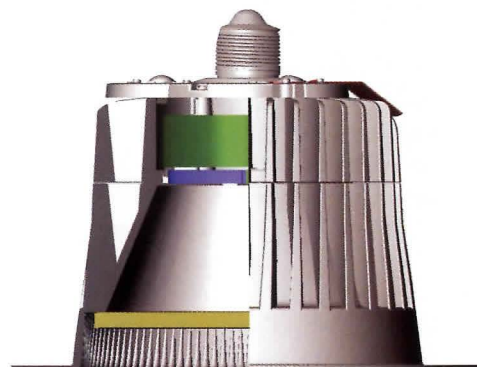

218

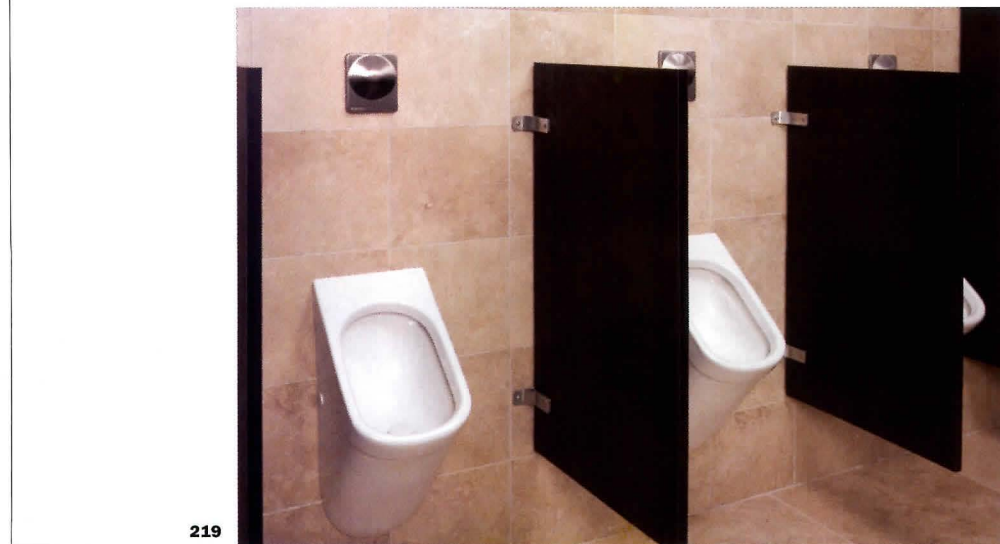

219



# Concrete & Masonry

Lightweight insulating concrete • Concrete reinforcing • Precast concrete • Stone assemblies

## Lightweight heavyweight

With a thermal value of R-52, Apex Block is a lightweight, insulating, concrete-block form weighing 51 pounds and made from over 90 percent recycled expanded polystyrene, cement, and other bonding agents. Apex walls deliver superior strength while providing a 4-hour burn rating and an average energy savings of over 60 percent. Apex Construction Systems, Portland, Ore. [www.apexblock.com](http://www.apexblock.com)

CIRCLE 220

## Kit of stone parts

Artisan Stone is 100 percent natural granite and quartzite stone masonry, designed and precision cut using CAD/CAM, and then hand-tooled. Each pre-cut stone is numbered according to the approved design plan. The project installs in 10 percent of the time required for normal masonry with no mess to clean up. New World Stoneworks, Uxbridge, Mass. [www.newworldstoneworks.com](http://www.newworldstoneworks.com)

CIRCLE 221

## Good to see you again

EcoX is a cement-based composite material composed of up to 70 percent postconsumer and postindustrial recycled materials. The material can be used to create made-to-order, finished modern concrete products, including surfaces, fixtures, and furniture. Meld USA, Raleigh. [www.meldusa.com](http://www.meldusa.com)

CIRCLE 222

## Half the size, twice as strong

Ducon micro-reinforced concrete has a compressive strength up to 29,000 psi and flexural strength up to 11,000 psi. It can reduce the size of concrete panels and structural members by up to 50 percent and provides up to twice the blast, ballistic, and seismic resistance of conventional reinforced concrete. Excend, Woodcliff Lake, N.J. [www.excendinc.com](http://www.excendinc.com)

CIRCLE 223

## Concrete cinema

Innovation Lab has developed a transparent concrete screen that can be used to animate exterior and interior walls. The heavy screen consists of concrete with embedded optical fibers, arranged as pixels that are capable of transmitting natural and artificial light. Innovation Lab, Aarhus, Denmark. [www.innovationlab.dk](http://www.innovationlab.dk)

CIRCLE 224

There is continuing innovation in concrete products using recycled and reprocessed components and aggregates that enhance their fire, thermal strength, and weight properties. —JACOB ALSPECTOR



220



221

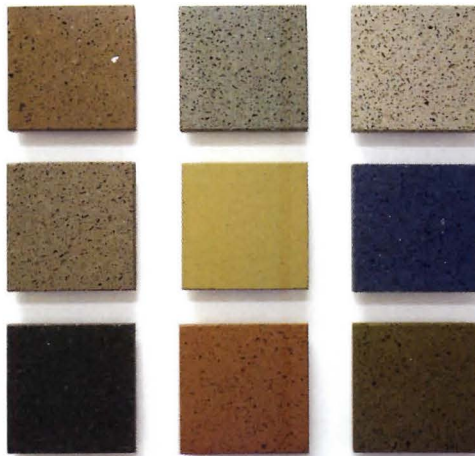

222

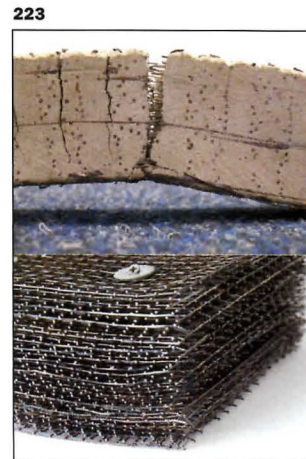

223

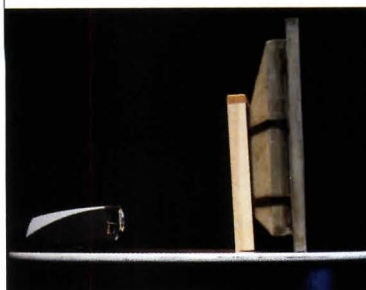

224





# JuliusBlum&Co.Inc.

## Titanium: The New Architectural Metal



**JuliusBlum&Co.Inc. is proud to introduce the first titanium handrail bracket, in stock, now available.**

Because of titanium's high strength, Julius Blum & Co. designed the bracket to be thinner and lighter. Silver-gray and softly reflective in appearance, titanium is non-reactive and can be combined with bronze, aluminum, steel or stainless handrails. Eco-friendly and low maintenance, titanium has outstanding corrosion resistance



and requires no additional finishing.

**Email us at [bluminfo@juliusblum.com](mailto:bluminfo@juliusblum.com) today for your free copy of our current Catalog and accompanying CD to view our inventory in aluminum, bronze, nickel-silver, stainless steel and malleable iron. All items shown in our literature are carried in stock in large quantities for prompt shipment. Full product details and CAD drawings are also available on our website, [www.juliusblum.com](http://www.juliusblum.com).**

**JuliusBlum&Co.Inc.** P.O. Box 816 Carlstadt, NJ 07072 ■ 800 526 6293 ■ 201 438 4600 ■ Fax 201 438 6003 ■ [www.juliusblum.com](http://www.juliusblum.com)

CIRCLE 59 ON READER SERVICE CARD OR GO TO [ARCHRECORD.CONSTRUCTION.COM/PRODUCTS/](http://ARCHRECORD.CONSTRUCTION.COM/PRODUCTS/)



# Metals, Wood, Plastics & Composites

Decorative metal • Metal specialties • Prefinished paneling • Structural panels • Composite fabrications • Wood paneling • Wood decking • Millwork

## Woven walls

Palm Woven is the latest addition to Smith & Fong's Durapalm collection of flooring and plywood. Derived from plantation-grown coconut palms at the end of their life cycle, Durapalm is composed of multiple layers from the tree's hard, dark perimeter for a stable and durable panel. The finger-joint design of these textured panels snap together for easy installation on walls and other surfaces. Smith & Fong, San Francisco. [www.durapalm.com](http://www.durapalm.com)

CIRCLE 225

## Mattress makeover

In her eclectic collection, Susan Woods often converts abandoned everyday items into functional art. Her Flatweave Tapestry refashions disused mattress springs into free-hanging space dividers, window treatments, retail fittings, and furnishings. Aswoon/Susan Woods Studio, Brooklyn, N.Y. [www.aswoon.com](http://www.aswoon.com)

CIRCLE 226

## Construction for dummies

Simpson Strong-Tie's two-story stacked Steel Strong-Wall structural panel offers a complete stacked-wall solution for two-story applications with the same anchor-bolt template as a single-story application. No bearing plates are needed to install. Simpson Strong-Tie, Pleasanton, Calif. [www.strongtie.com](http://www.strongtie.com)

CIRCLE 227

## Ethereal material

Inspired by traditional Indian perforated-stone screens, Jali is Sensitile's new light-refractive polymer panel. Available in several lacelike patterns, applications include room dividers, lighting, signage, and furniture. Standard panel size is 4' x 8' x 3/8" thick. Sensitile Systems, Detroit. [www.sensitile.com](http://www.sensitile.com)

CIRCLE 228

## Greener particleboard

Complementing an existing line of formaldehyde-free hardwood plywood products, Columbia this year began producing formaldehyde-free PureBond particleboard. The PureBond formula is enhanced with a proprietary soy-based adhesive, giving it strong bonding and water-resistant qualities while improving indoor air quality. Columbia Forest Products, Portland, Ore. [www.columbiaforestproducts.com](http://www.columbiaforestproducts.com)

CIRCLE 229

The use of wood products without formaldehyde will be increasingly important. It's good to see the industry responding to this need. —JACOB ALSPECTOR



225

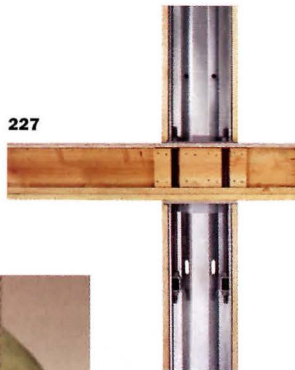

227

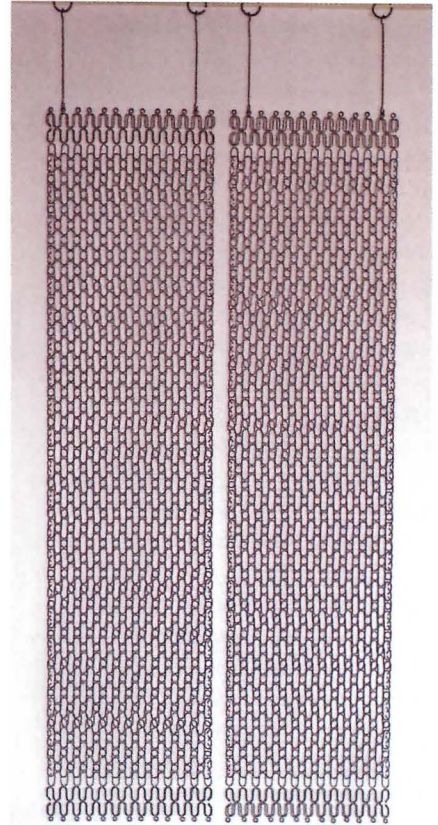

226



228

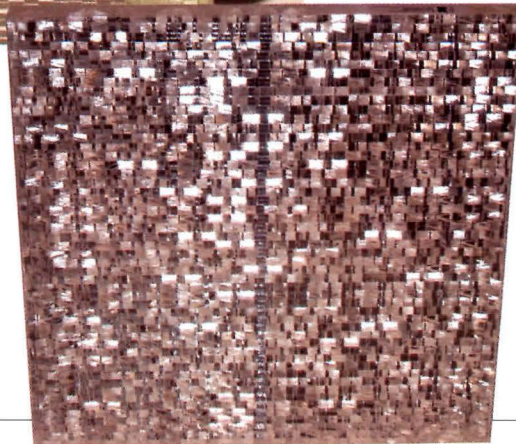

229



# Metals, Wood, Plastics & Composites

Composite fabrications • Prefinished paneling • Structural panels • Millwork • Metal specialties

## Brace yourselves

iLevel Shear Brace provides the strength and support necessary to help homes resist large lateral loads from high winds, hurricanes, and earthquakes. Available in narrow widths of 12" or 18" for greater design flexibility, and in lengths up to 20' for tall wall framing and multistory applications, the panels maximize the key shear-wall parameters of allowable load and stiffness. iLevel is made from TimberStrand laminated strand lumber, which can be trimmed or shimmed in the field for custom heights. iLevel by Weyerhaeuser, Federal Way, Wash.

www.iLevel.com **CIRCLE 230**

## It's a wrap

Contact Industries developed these dimensionally stable, fire-rated window louvers for a recent remodel at King's College in London. White oak veneer was wrapped over an extruded aluminum core in this case, but virtually any wood species could be used to create this long-lasting and aesthetically pleasing option for window coverings. Contact Industries, Clackamas, Ore.

www.contactind.com **CIRCLE 231**

## Saturated color

Chroma solid-resin panels from 3form are available in a diverse palette of colors that have radiant possibilities when lit. Developed in conjunction with Bayer Material Science, Chroma features Aura, a proprietary color-infusion process that allows 3form to infuse nontoxic colorant at a depth of 250 microns. To encourage recycling, 3form will buy back the panels and reprocess them through its Reclaim program. The material can also be "leased" for a defined period of time and then returned for reprocessing. 3form, Salt Lake City. www.3-form.com **CIRCLE 232**

## Mix-and-match surfaces

Myriad Wall Systems features an extruded aluminum framework that allows interchangeable panels to easily snap in and out, so users can mix, match, accent, or change wall statements. Panel options include wood and metal veneers, perforated metals, decorative laminates, stone, fabric, and acoustic material. Clear and translucent acrylics with patterns and images for decorative backlighting are also available. Marlite, Dover, Ohio.

www.marlite.com **CIRCLE 233**

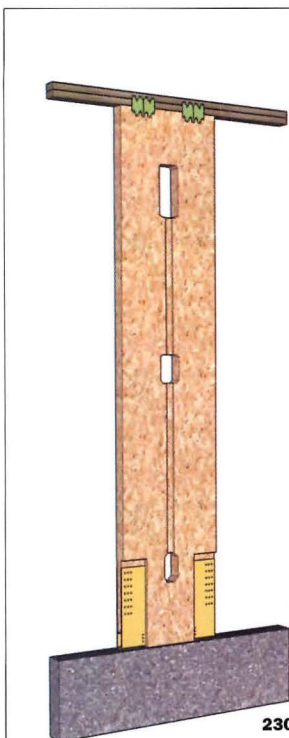

**230**

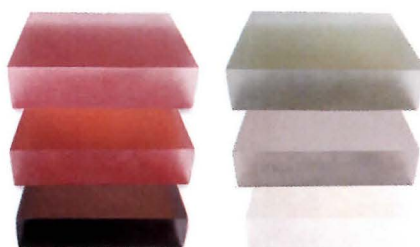

**232**



**231**



**233**





# Continuing Your Education Never Looked So Good



Brindisi & Yaroscak Custom Builders, Inc.  
Architect: Bartels Pagliaro Architects  
Photo: Olson Photographic

Train with the best. We've been educating the marketplace since 1915 and offer free seminars on cedar shakes and shingles. Come and learn about the wind, fire and impact resistance of an environmentally sound building material, handcrafted with pride by our members.



tel: **604-820-7700** fax: **604-820-0266**

**[www.cedarbureau.org](http://www.cedarbureau.org)**





# Metals, Wood, Plastics & Composites

Composite fabrications • Prefinished paneling • Structural panels • Millwork • Metal specialties

## Hit the deck

Suitable for most outdoor decking applications, Wolmanized L3 Outdoor Wood features a nonmetallic, carbon-based preservative that provides lasting resistance to termites and fungal decay. It can be painted or stained without discoloration from the preservative, which has low impact on hardware and woodworking tools. Arch Treatment Technologies, Smyrna, Ga. [www.wolmanizedwood.com](http://www.wolmanizedwood.com)

CIRCLE 234

## Eco-friendly hardwood

The entire line of GreenT Hardwood Plywood is available with a special no-added-urea formaldehyde resin and several core options such as MDF, veneer, or particleboard, all produced with recycled wood fibers. Timber Products Company, Springfield, Ore. [www.timberproducts.com](http://www.timberproducts.com) CIRCLE 235

## An exotic look for less

Made from plantation-grown, renewable timber such as pine, Alowood is a natural wood that is organically hardened and colored for a denser, stronger wood than the original that can be produced in virtually any color. EverTech, Ferndale, Wash. [www.alowood.com](http://www.alowood.com) CIRCLE 236

## Custom comes standard

More affordable and with shorter lead times than custom millwork, Armstrong's WoodWorks Ekos Walls have no detectable formaldehyde emissions. The lightweight, 2'-wide panels consist of real wood veneers and an acoustical, mineral fiber substrate. The perforated-panel option absorbs up to 45 percent of sound. Available in mahogany, maple, light cherry, and dark cherry. Armstrong Ceiling and Wall Systems, Lancaster, Pa. [www.armstrong.com](http://www.armstrong.com) CIRCLE 237

## Catch and Release

Reelease is a motorized-retractable-attachment method for metal fabric applications first developed by Cambridge Architectural for the Planet Hollywood Theatre for the Performing Arts in Las Vegas. The Reelease system employs a concealed, overhead-mounted reel that raises and lowers corresponding metal-fabric patterns at the touch of a button to define and separate large interior spaces. Cambridge Architectural, Cambridge, Md. [www.cambridgearchitectural.com](http://www.cambridgearchitectural.com)

CIRCLE 238



234

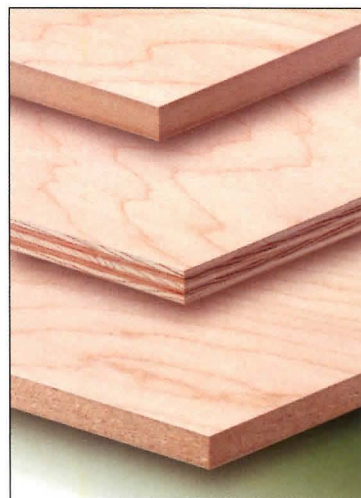

235



236



237

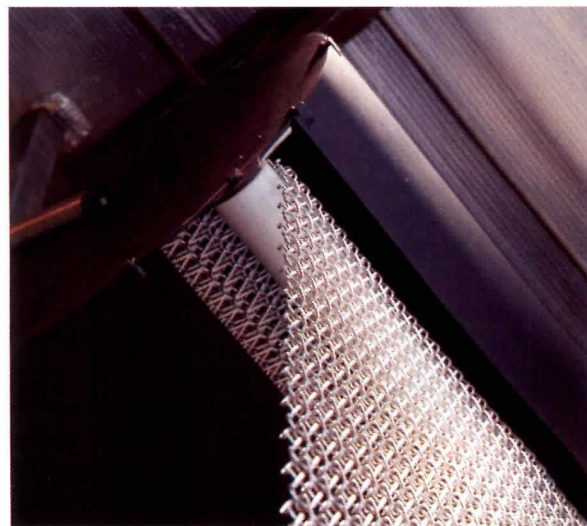

238



# Thermal & Moisture Protection

Dampproofing & waterproofing • Air barriers • Wood siding • Membrane roofing • Intumescent mastic fireproofing • Sealants, caulking & seals

## Green Roof Inn

Sika Sarnafil has green-roof systems for use on both concrete and metal deck applications. Its G476 Self-Adhered membrane is specially designed for sub-grade environments. It is compounded to remain watertight in extreme conditions, including ponding water and exposure to plant roots, fungi, and bacterial organisms. No flammable adhesives or hot asphalt kettles are required, making installation safe and easy. Pictured here is an extensive green roof planted with more than 6,000 sedum plants. Sika Sarnafil, Canton, Mass. [www.sarnafil.com](http://www.sarnafil.com)

CIRCLE 239

## The shear strength of it

Manufactured in Austria and recently made available in the U.S., BBS multilayered, solid wood cladding panels double as a structural wall. By laminating longitudinal and cross layers, the wood achieves greater strength and stability. The panels are made up of 99.4 percent solid wood, either Austrian Red Spruce or Larch, and .6 percent formaldehyde-free glue, whose vapor-inhibiting properties allow the panels to be installed without vapor or wind barriers. Walls can be composed of vertically as well as horizontally placed panels. Available in multiple thicknesses and profiles. Roof and floor panels are also available. HolzBuild, Ossining, N.Y. [www.holzbuild.com](http://www.holzbuild.com) CIRCLE 240

## Sticky rolls

Eternabond's DoubleStick is a self-sealing adhesive that creates a tight, permanent, waterproof seal between two or more similar or dissimilar surfaces. Made from synthetic resins, thermoplastics, non-curing butyl rubbers, and a built-in primer, the product is sandwiched between two layers of removable protection film. It is ideal for use as a gasket when installing windows or vents, or as a lap seal under the foot of an equipment curb or skylight, and remains fused and flexible in extreme temperatures. DoubleStick comes in standard 50' rolls in 2", 4", or 6" widths. Eternabond, Mundelein, Ill.

[www.eternabond.com](http://www.eternabond.com) CIRCLE 241

It's great to see how HolzBuild's Solid Wood Panels provide a monolithic, renewable material that can provide both structure and envelope with simple detailing. —ERIC BUNGE, AIA

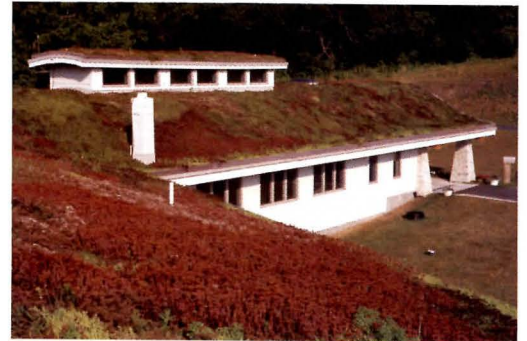
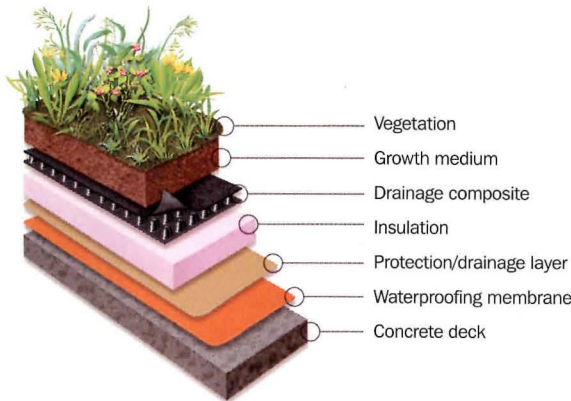

239

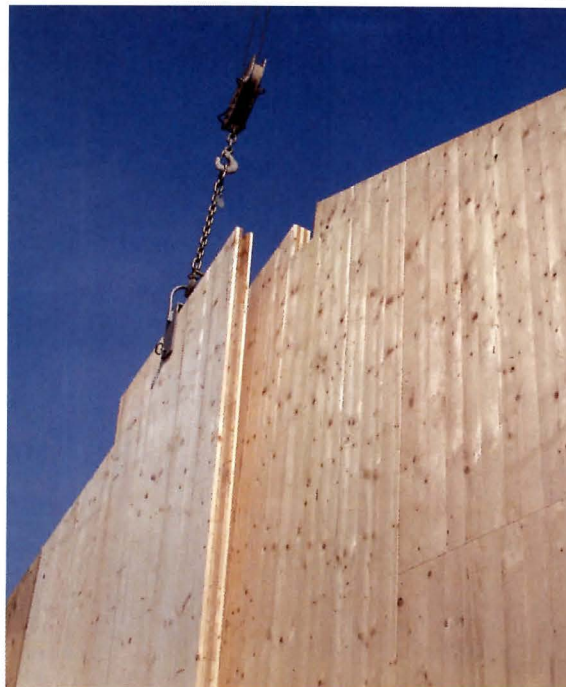

240



241



# Thermal & Moisture Protection

Dampproofing & waterproofing • Air barriers • Wood siding • Membrane roofing • Intumescent mastic fireproofing • Sealants

## Seal the envelope, please

DuPont's Roofliner with Elvaloy is a roofing underlayment that provides superior durability and protection against leaks compared to roofing felt, and is five times lighter. Tyvek Commercial Wrap D has a specially engineered surface texture that provides an enhanced drainage plane for wall systems and climates that require additional drainage. The new Weatherization Sealant (not pictured) works with the Tyvek systems to protect homes from air and moisture infiltration. DuPont, Wilmington, Del. [www.dupont.com](http://www.dupont.com) **CIRCLE 242**



242

## Rooting for green roofs

EnkaRetain & Drain matting was developed for roof garden and planter applications. The fabric absorbs water for continuous hydration of plant roots, while excess water passes through to the drainage core. Made from postindustrial, recycled polypropylene. Colbond, Enka, N.C. [www.colbond-usa.com](http://www.colbond-usa.com) **CIRCLE 243**



243

## A strong return on bonds

Green-Lock is a 100 percent solids, VOC-free, single component structural adhesive that ensures a strong bond to a multitude of materials throughout the building envelope. When cured, it provides 300 pounds of shear strength when bonding wood, metals, and masonry. The Garland Company, Cleveland. [www.garlandco.com](http://www.garlandco.com) **CIRCLE 244**



244

## Put the tray down

The Advanced Vegetative Roof System (AVRS) is a water-efficient green-roof system that incorporates Zeba-branded moisture-release technology for faster, fuller vegetation establishment and lower maintenance costs. The partially recycled AVRS trays, which weigh only 15 pounds per square foot when fully saturated, interlock for easy assembly and removal, and to prevent movement. Columbia Green Technologies, Wilsonville, Ore. [www.columbiagreenroof.com](http://www.columbiagreenroof.com) **CIRCLE 245**



245

## Off-site solutions to fire safety

Interchar 212 is a VOC-free, epoxy-based, intumescent fireproofing coating designed for fast-track construction and shop application. The inherent anticorrosive properties and flexibility of finish textures are ideally suited for architectural steelwork. International Paint, Houston. [www.interchar.com](http://www.interchar.com) **CIRCLE 246**



246

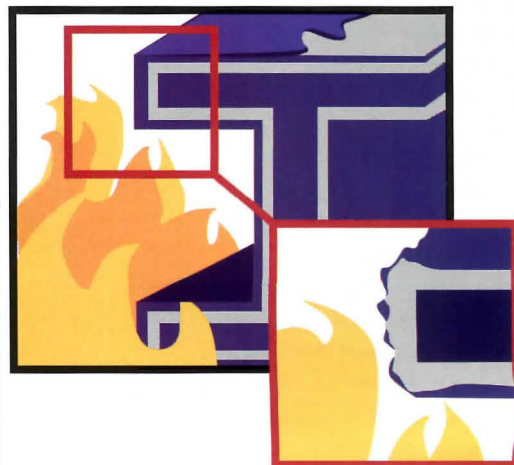



# Openings

Folding doors & grilles • Window & door hardware • Glass & glazing • Wood windows & doors • Fiberglass windows & doors

## Panoramic panels

The Lift & Slide and Folding Door Systems provide expansive, easy-to-operate openings. The Lift & Slide panels can either nest behind one another and stack to one or both sides of the opening, or recess into a pocket constructed within the finished wall to disappear completely from view. Folding panels fold back against each other. Both systems provide three sill-design choices to unobtrusively transition between indoor and outdoor spaces. Panels come in a heavy-duty, extruded aluminum in a variety of colors on the exterior, with wood options for the interior. Kolbe & Kolbe Millwork Co., Wausau, Wis. [www.kolbe-kolbe.com](http://www.kolbe-kolbe.com) **CIRCLE 247**

## A warped view

Nathan Allan Glass Studios has added Circles and Triangles to their geometrically themed series of Convex glass. The gridded pillows of this textureless cast glass distort the image beyond, providing privacy while allowing the maximum amount of natural light to filter through. Panels of various thickness are available as large as 8' x 12'6", simulating many rows of glass block without grout lines. Convex glass is available in clear and low-iron glass. An optional opacity coating for both indoor and outdoor applications gives the glass a sand-blasted appearance while repelling dirt and fingerprints. Nathan Allan Glass Studios, Richmond, B.C., Canada. [www.nathanallan.com](http://www.nathanallan.com)

**CIRCLE 248**

## Good looks for locks

Metro Elements is the first line in Sargent's new Studio Collection of architectural door hardware. The line includes 23 contemporary levers that are functionally compatible with all of Sargent's commercial-grade mortise and tubular locks, access control locks, exit devices, and master key systems, integrating high demands for both aesthetics and security. Thirteen finishes, including satin or polished brass, bronze, nickel, chrome and stainless steel, are available. Sargent Manufacturing, New Haven. [www.studiocollection.com](http://www.studiocollection.com) **CIRCLE 249**

The point of a window is to open up a view and go away. New materials such as fiberglass allow for more openness while addressing issues of sustainability. —CHARLES RENFRO, AIA



247



248



249



# Openings

Folding doors & grilles • Window & door hardware • Glass & glazing • Wood windows & doors • Fiberglass windows & doors

## Certified wood alternative

Bieber USA's custom-designed windows and doors are made from solid, three-ply seasoned eucalyptus harvested from FSC-certified South American plantations for a low-maintenance, renewable hardwood alternative to mahogany and teak options. The custom-designed windows and doors are finished with water-based finishes. Unlike traditional American windows, Bieber's tilt-and-turn functionality allows the windows to open completely inward. Bieber USA, Tustin, Calif. [www.bieberusa.com](http://www.bieberusa.com) **CIRCLE 250**

## High fiber diet

VT Industries Architectural Wood Doors are Greenguard-certified for Children and Schools and Indoor Air Quality. Doors are produced in an environmentally friendly facility and are made from recycled or recovered material, including agricultural fiber content. Door options include five-ply wood veneer and high-pressure decorative laminate flush doors. VT Industries, Holstein, Iowa. [www.vtindustries.com](http://www.vtindustries.com) **CIRCLE 251**

## When one door closes

The TS93 from Dorma is a hydraulic, surface-applied closer with regular-arm operating efficiency and track-arm aesthetics, eliminating protruding double-lever arms. The steel cam and roller design reduces the effort required to open a door while preventing uncontrolled opening and allowing for hold-open options. An adjustable delayed action extends the closing cycle to permit unobstructed passage through the opening. Available in several finish options. Dorma Architectural Hardware, Reamstown, Pa. [www.dorma-usa.com](http://www.dorma-usa.com) **CIRCLE 252**

## Double the durability

Pella has added a double-hung window to its Impervia line of energy-efficient windows made from Duracast, the company's durable engineered fiberglass composite. The windows come in three sash-split options—traditional, contemporary, and cottage. The sash tilts in for convenient glass cleaning from the inside. Windows are available with a variety of color, glass, muntin, and hardware options. Pella Corporation, Pella, Iowa. [www.pellacommercial.com](http://www.pellacommercial.com) **CIRCLE 253**

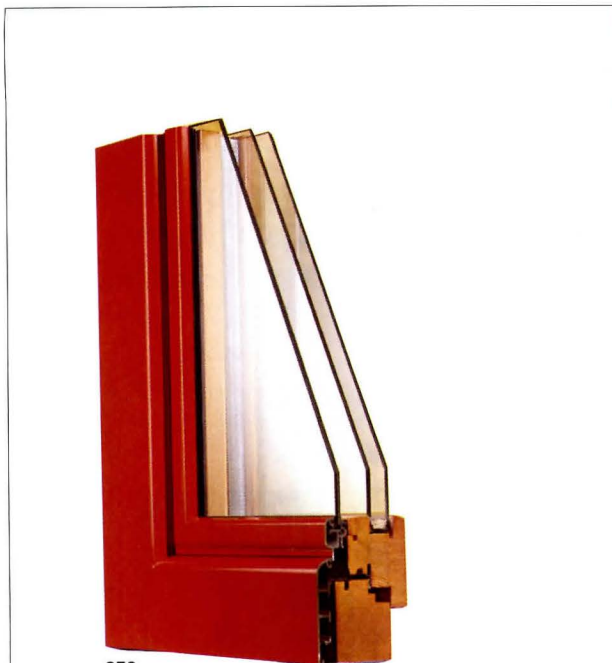

250



251

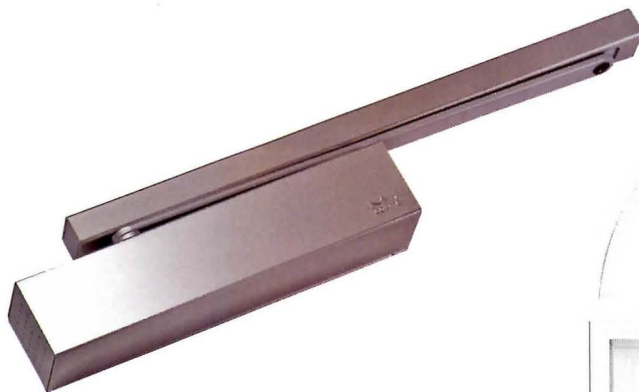

252



253





**SARGENT**

**ASSA ABLOY**

GREAT LOOKS. GREAT LOCKS.  
superbly stylized trim for every door opening

Mortise Locks | Tubular Locks | Access Control  
Exit Devices | Master Key Systems

**Studio** collection  
studiocollection.com

eero  
saarinen  
shaping  
the  
future

ASSA ABLOY is the global sponsor of the Eero Saarinen: Shaping the Future exhibition which will travel to Bloomfield Hills, MI; Washington, D.C.; Minneapolis, MN; St. Louis, MO and New Haven, CT through 2010.  
[www.eerosaarinen.net](http://www.eerosaarinen.net)



ASSA ABLOY Door Security Solutions is a registered Passport Provider of continuing education with the American Institute of Architects and an AAF Cornerstone Partner.



# Openings

Folding doors & grilles • Window & door hardware • Glass & glazing • Wood windows & doors • Fiberglass windows & doors

## Monumental vistas

Nana Wall's SL70 Energy Star Hurricane Folding System is a monumentally sized, thermally broken aluminum folding panel system designed to provide a glass wall opening up to 36' wide x 8'2" tall. Nana Wall Systems, Mill Valley, Calif. [www.nanawall.com](http://www.nanawall.com) **CIRCLE 254**

## When your home is your castle

The Tru-Defense System for Entry and Patio Doors contains components that have been designed to work together to form the tightest seal possible, protecting homes from severe weather. Crafted of fiberglass, the doors feature impact-rated glass assembled directly into the door, making the door and glass one solid piece. The Tru-Defense Opaque Impact Rated Doors include a steel plate underneath the skin for added strength and rigidity. The system is Energy Star-compliant and offers five times the insulation of wood. Therma-Tru Doors, Maumee, Ohio. [www.thermatru.com](http://www.thermatru.com) **CIRCLE 255**

## Good to see you again

Available in 110" x 49" x 3/4" slabs, Bio-Glass is made from 100 percent postindustrial or postconsumer recycled content and is recyclable. For use in countertops or worktops, interior flooring, or accent walls, the glass has a multidimensional appearance and its coloring varies with direct and indirect light. The product is completely inert and does not produce any off-gassing. It is offered in polished, honed, and natural finishes. Coverings Etc, Miami. [www.coveringsetc.com](http://www.coveringsetc.com) **CIRCLE 256**

## Cutting corners

A new option for Jeld-Wen's Exterior Folding Door System is a 90 degree configuration that can be completely opened to the outdoors without a structural corner post, opening up two wall spans in a room. The doors fold back accordion-style from the corner inward. Beveled door edges and double weather strips ensure that the units are sealed against the elements. Panels are available in either Jeld-Wen's Aurora custom fiberglass or hardwood. The door frame can be clad with any Jeld-Wen standard color to match windows. Energy-efficient, low-E glass is available. Jeld-Wen, Klamath Falls, Ore. [www.jeld-wen.com](http://www.jeld-wen.com) **CIRCLE 257**



254

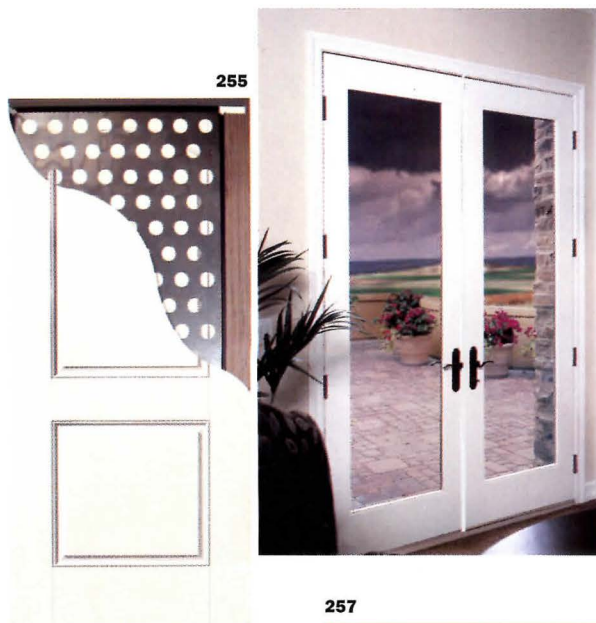

255

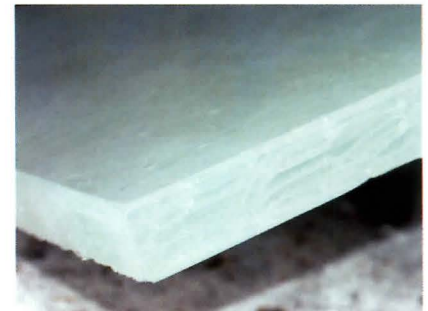

256

257





Before



After



**JELD-WEN® windows and doors will look just as great tomorrow as they do today.**

That's because each one is built to last. We prove this with features like our 20-year warranty for products built with solid pine AuraLast® wood, which protects against wood decay, water absorption and termites. To learn more call 1.800.877.9482, ext. 1401, or visit [www.jeldwen.com/1401](http://www.jeldwen.com/1401).



**RELIABILITY** *for real life*®

**JELD-WEN**  
WINDOWS & DOORS

CIRCLE 66 ON READER SERVICE CARD OR GO TO [ARCHRECORD.CONSTRUCTION.COM/PRODUCTS/](http://ARCHRECORD.CONSTRUCTION.COM/PRODUCTS/)



# Finishes

Plaster & gypsum board • Tiling • Carpeting • Fluid-applied flooring • Textile wall coverings • Acoustic room components

## Beyond square

The Paula Navone-designed ceramic bathroom tiles by Viva are available in three series: the blue and white circular Brut & China tiles (pictured); the silvery, dot-patterned Vintage; and Seafoam, a colorful collection of coral reef and under-the-sea motifs. The tiles can be altered in shape and size for washbasin, console, and accessory design. Italian Trade Commission, Ceramic Tile Dept., New York City. [www.cerviva.it](http://www.cerviva.it) **CIRCLE 258**



258

## 3D wall "paper"

Designed to absorb unwanted cacophony, Anne Kyyrö Quinn's 100 percent felt wool wall installation not only quiets a room's decibel count, but it also offers a softer 3D alternative to wallpaper. The elegant loops and folds create interesting shadows and depth to a typically flat surface. Anne Kyyrö Quinn, London. [www.annekyyroquinn.com](http://www.annekyyroquinn.com) **CIRCLE 259**



260

## Picture this

With Progetto Aperto's porcelain stoneware tiles, photographs of grass, water, or flowers are silk-screened onto a white-based tile to create an illusion of a lawn, pond, or field. Specifiers can also submit a unique photograph to create a one-of-a-kind wall or floor pattern. Italian Trade Commission, Ceramic Tile Dept., New York City. [www.mutina.it](http://www.mutina.it) **CIRCLE 260**

## Can you hear me now?

The Sticks felt-covered panels were designed by Jean-Marie Massaud as part of the Soundwave series of acoustical buffers. All Soundwave products are designed to absorb light, high-frequency noise at 500 Hz and above. Offecct, Tibro, Sweden. [www.offecct.se](http://www.offecct.se) **CIRCLE 261**

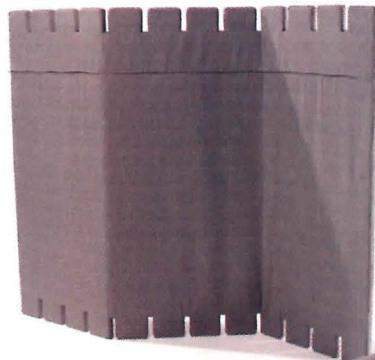

## Magic carpet

The Sasan rug is not just any floor covering; it can be shaped into a bed, a lounge, or placed upright as a screen. Created by the young German designer, Alexander Munk, Sasan is not yet in production but is available on request. Munk hopes to develop a lower-cost version with a manufacturing partner for both indoor and outdoor use. Alexander Munk, Krefeld, Germany. [www.munk-a.de](http://www.munk-a.de) **CIRCLE 262**



262

259



266

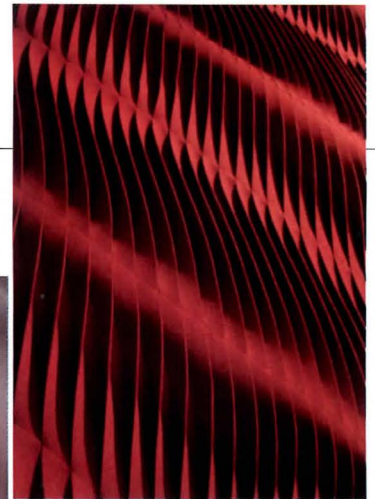



I like the relationship between Leaf Cushion's acoustical and spatial properties achieved by simply twisting felt strands into many possible 3D patterns. —ERIC BUNGE, AIA



263

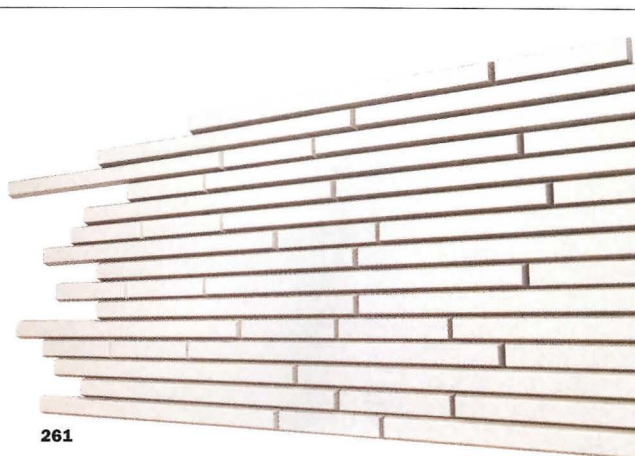

261



265



264



267



**Trend-y green**

The new ecologically mindful Trend Q stone-flooring collection is made of 72 percent postconsumer recycled glass and quartzite. These glossy, 12" tiles come in 50 colors and are water-resistant, making them ideal for countertops, floors, and showers. Trend USA, Miami. [www.trend-vi.com](http://www.trend-vi.com) **CIRCLE 263**

**Textured tile**

Available in 18 colors, the 12"-square porcelain Stream tiles from Cermica di Treviso are an edgy alternative to standard flooring. The 3D surface creates a unique, bumpy texture that casts interesting shadows. With a water-absorption of 0.2 and a PEI rating of 4, the tiles can be used for swimming pool flooring. Italian Trade Commission, Ceramic Tile Dept., New York City. [www.ceramicaditreviso.it](http://www.ceramicaditreviso.it) **CIRCLE 264**

**Well-dressed floors**

Shaw's redesigned Dressed to Kill collection includes 12 tile options and four broadloom patterns and features both Eco Solution Q fiber and EcoWorx tile backing. Both fiber and backing are fully recyclable in a closed-loop, Cradle to Cradle process. Tiles designated as "Vivid" feature bright colors with contrasting accent stripes and are intended for workplace settings; "Lux" tiles, for professional service applications, feature a more monochromatic palette. Shaw Contract Group, Dalton, Ga. [www.shawcontractgroup.com](http://www.shawcontractgroup.com) **CIRCLE 265**

**Wooden rug**

Woodnotes' Coast Paper Yarn Carpets offer a soft twist to typical wooden floors. The carpets are made of a compacted wood fiber that is spun into paper yarn. Available with a backing, the earthy rugs come in eight monochromatic colors. Woodnotes, Helsinki, Finland. [www.woodnotes.fi](http://www.woodnotes.fi) **CIRCLE 266**

**Stoneware illusion**

Mikado porcelain stoneware from Ergon Engineered Stone offers a playful illusion of polished bamboo, mahogany, or ebony. The stoneware slabs can be used for flooring, wall tiles, and specialty pieces to unite a room's motif. Italian Trade Commission, Ceramic Tile Dept., New York City. [www.ergontile.com](http://www.ergontile.com) **CIRCLE 267**



# Finishes

Plaster & gypsum board • Tiling • Carpeting • Fluid-applied flooring • Textile wall coverings • Acoustic room components

## Writing on the wall

The Digital collection from Etruria Design features beveled tile with digital characters that "spell out" designs. Italian Trade Commission, Ceramic Tile Dept., New York City. [www.etruriadesign.it](http://www.etruriadesign.it) **CIRCLE 268**

## Concrete polishing system

The Induroshine process polishes an already-existing concrete floor with equipment used for grinding diamonds. The system mixes concrete's naturally occurring minerals with liquid. W.R. Meadows, Hampshire, Ill. [www.wrmeadows.com](http://www.wrmeadows.com) **CIRCLE 269**

## Sturdy panel

DensArmor Plus Abuse Guard paperless interior drywall is a gypsum-and-fiberglass panel designed for high-traffic areas. Georgia-Pacific Gypsum, Atlanta. [www.gpgypsum.com](http://www.gpgypsum.com) **CIRCLE 270**

## Moldproof gypsum

Mold Tough is a gypsum panel processed to protect the interior from moisture, quelling mold spores and damage from plumbing leaks and flooding. USG, Chicago. [www.usg.com](http://www.usg.com) **CIRCLE 271**

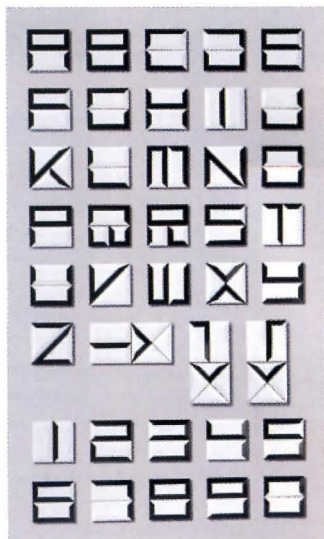

268



269

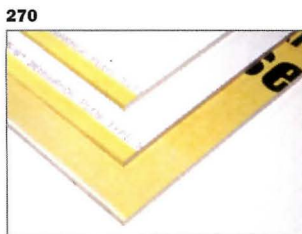

270



271

# Sublime. Enduring. And fast.



The car is also quite nice.

ArcusStone® decorative limestone coating has much in common with a Jaguar®. It's easy on the eyes. Comes in a variety of colors and finishes. And handles curves with aplomb.

Like a Jag, there's nothing faux about ArcusStone. The ArcusStonecoat™ you see here is real limestone, reconstituted with our proprietary formula. So it has the look, feel -- and with a compressive strength of 5,805 psi -- a level of endurance that's ahead of most anything out there.

And because it was specified for Jaguar dealerships, you'll find ArcusStonecoat alongside purring Jags across the country. Or behold it in the de Young Museum.

For more about ArcusStone products and their many uses, visit [www.arcusstone.com](http://www.arcusstone.com).



**ArcusStone®**



# Specialties

Visual-display surfaces • Operable partitions • Commercial-toilet accessories • Exterior sun-control devices

## Easy conversions

Bobrick's touch-free, folded-paper and roll-towel dispenser and waste units provide interchangeable modules permitting easy changeovers from folded to roll towels, and from 12- to 18-gallon waste receptacles, without removing the base cabinet from the wall. Bobrick Washroom Equipment, North Hollywood, Calif. [www.bobrick.com](http://www.bobrick.com) **CIRCLE 272**

## Keep on rolling

The SPS Stacking Partition System offers a variety of options to create a simple yet elegant space division or a large mall front. Ease of operation is attributed to the Intelli-Track Roller (detail shown) and overhead track design, which allows the panels to virtually glide and park themselves. C.R. Laurence, Los Angeles. [www.crlaurence.com](http://www.crlaurence.com) **CIRCLE 273**

## Sun and thermal control

ThermaShade is the industry's only sun-shade system with a thermal barrier, reducing solar heat gain and improving the thermal performance of building envelopes. Joinery is made through accessible, mechanical fasteners, and parts can be easily replaced. YKK AP America, Austell, Ga. [www.ykkap.com](http://www.ykkap.com) **CIRCLE 274**

## Clean slate

The e3 ceramic-steel surface for whiteboards and chalkboards is Greenguard certified and the first and only to achieve international Cradle to Cradle Silver certification. The surface consists of a steel core with a minimum of 30 percent pre- and postconsumer recycled content of .013" and .019" thickness covered on both sides with thin enamel coatings. PolyVision, Suwanee, Ga. [www.polyvision.com](http://www.polyvision.com) **CIRCLE 275**

## Dryer part deux

Excel Dryer's redeveloped Xlerator hand dryer features a noise reduction 1.1 nozzle that lowers the decibel level by 10 and eliminates practically all the sound deflection that occurs during drying. A durable brushed-stainless-steel finish has also been introduced in response to customer requests. Excel Dryer, East Longmeadow, Mass. [www.exceldryer.com](http://www.exceldryer.com) **CIRCLE 276**

This year, many companies seemed to step out and present a product with a design aesthetic, function, or materiality that was unexpected and most welcomed. —CHRISTIAN P. ARKAY-LELIEVER



272



273



275

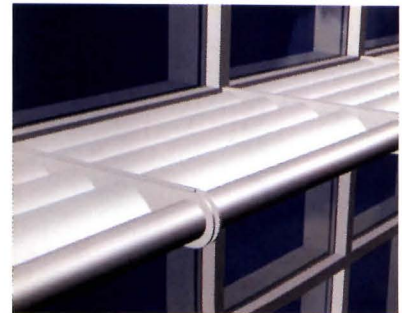

274



276





Morgan Library, New York - Project Renzo Piano Building Workshop  
Model RP 01 - Design Renzo Piano Building Workshop

Poltrona Frau Contract can provide standard and custom variations  
for auditoriums, theatres, airports, museums, restaurants, hotels and offices

145 Wooster St. New York, NY ph. 212 777 7592 fax 212 777 8481 [www.frauusa.com](http://www.frauusa.com) [frauusa@frauusa.com](mailto:frauusa@frauusa.com)



CIRCLE 69 ON READER SERVICE CARD OR GO TO [ARCHRECORD.CONSTRUCTION.COM/PRODUCTS/](http://ARCHRECORD.CONSTRUCTION.COM/PRODUCTS/)



# Equipment

Residential kitchen appliances • Residential laundry appliances

## Smart cooker

Thermador's Silver Mirrored Induction cooktop features a comprehensive set of safety features such as anti-overflow, automatic stop, and cookware-detection systems, as well as a child lock, anti-overheating sensor, and residual heat indicator. Available in 30" and 36" sizes. Thermador, Huntington Beach, Calif.

www.thermador.com **CIRCLE 277**

## Cool, calm, and carbonated

The Exubera Sparkling and Chilled Water Appliance cools water to 40 degrees Fahrenheit and carbonates up to 6.6 gallons of water per hour. Made of stainless-steel components, the appliance can be installed under almost any kitchen cabinet or wet bar. It uses ozone-friendly refrigerant and can be combined with a water filter. Everpure, Hanover Park, Ill.

www.everpure.com **CIRCLE 278**

## Green and clean

Bosch's Evolution dishwashers boast a series of technical innovations: a very low, 42-decibel sound level while running; the ability to use as little as 1.8 gallons of water per cycle; and an Ecoaction button, which reduces energy consumption by 25 percent. The company's Next 500 Plus/800 Laundry Washers also feature the Ecoaction energy-saving setting, which can decrease the energy used during a cycle by 20 percent. The washers, which exceed 2007 federal regulatory standards for energy, come in silver, white, champagne, and silver duo-tone (800 series only). Bosch's wall ovens (not shown) feature a 7-minute preheat setting, and 30" models have the largest capacity on the market at 4.7 cubic feet. Bosch, Huntington Beach, Calif.

www.boschappliances.com **CIRCLE 279**

## On the rise

With a press of a button, Gaggenau's Lift Oven's glass ceramic base lowers directly from the oven to the countertop, where food can be loaded and then raised into the cooking cavity. This LiftMatic function increases kitchen safety while ensuring minimal energy loss. Gaggenau, Canton, Mass. www.gaggenau-usa.com **CIRCLE 280**

Exubera seems like a luxury as a carbonated-water dispenser, but it saves in packaging and waste. And it's fun.

—CHARLES RENFRO, AIA



277



278



279



280





# Furnishings & Exterior Improvements

Window treatments • Countertops • Residential furniture • Office furniture • Site furniture • Upholstery fabrics • Bathroom furnishings • Fencing

## A designer's legacy

Designed by the late Maarten Van Severen (and carried through by his former assistant), Pastoe's leather lounge chair features a one-sided mounted armrest and a cross-stitched leather cover that is screwed to the stainless-steel frame. Pastoe, Utrecht, the Netherlands. [www.pastoe.nl](http://www.pastoe.nl) **CIRCLE 281**

## A seat in time

Originally designed in 1953, Ahrend's steel-framed Revolt chair is not only a classic, but ergonomic as well. Revolt supports a flexible composite back made of polyester resin that moves with the user. Available exclusively in the U.S. through Allsteel. Allsteel, Muscatine, Iowa. [www.allsteeloffice.com](http://www.allsteeloffice.com) **CIRCLE 282**

## Right in context

This leather upholstered Xcone chair, designed to accompany Rosenthal Einrichtung's Context table, is supported by a base of four steel tubes that converge at a swivel joint. Available in eight colors, these chairs add a modern twist to the traditional conference table. Riservato & Company, New York City. [www.rosenthaleinrichtung.de](http://www.rosenthaleinrichtung.de) **CIRCLE 283**

## Have you heard?

Artist Alyce Santoro designed Sonic, a fabric created from 49 percent recycled audiotapes with multilayered audio tracks recorded into the fabric. Designtex, New York City. [www.designtex.com](http://www.designtex.com) **CIRCLE 284**

## Indoor/outdoor amusement

Unika Vaev's Amusement Collection features four designs—Moxie, Tilt-a-Whirl, Parade, and Champ—for indoor or outdoor use. The line is woven of 100 percent Bella-Dura fiber, which can withstand UV light, salt, mildew, and extreme temperatures. Unika Vaev, Taftville, Conn. [www.unikavaev.com](http://www.unikavaev.com) **CIRCLE 285**

## Lock onto this

This uniquely shaped bicycle rack is made by the Barcelona atelier Lagranja. Inspired by the look of antique key heads, the cast-iron-based rack and steel outline are covered in polyurethane foam. Available in black and red. Ameico, New Milford, Conn. [www.ameico.com](http://www.ameico.com) **CIRCLE 286**



287



282



283



292

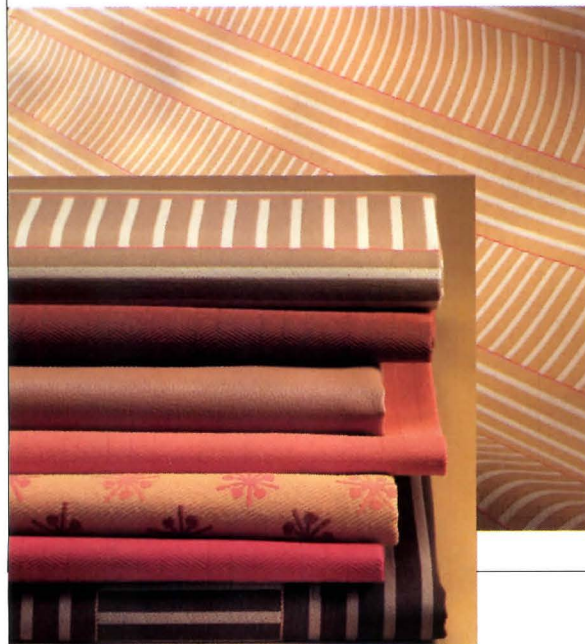

285



286



The products I found most compelling were those that questioned typological definition while opening up new possibilities for performance. —ERIC BUNGE, AIA



281



293



293



290



289



284



291



288

**Odd combo**

The Misfit modular-seating system features polyurethane foam-covered steel-frame sections that can be mixed and matched to create an unusual seating area. Moroso USA, New York City. [www.morosousa.com](http://www.morosousa.com) **CIRCLE 287**

**Eastern view**

Ogee curtain fabric is composed of white and black yarns that are woven into an oval pattern inspired by the historic arches of the Middle East. Swirl window fabric (not shown) offers a lustrous sheen while filtering light. Kova Textiles, New York City. [www.kovatextiles.com](http://www.kovatextiles.com) **CIRCLE 288**

**Strength in simplicity**

Designed by Bertjan Pot, the high-end, Slim exterior table is constructed of steel with a thin layer of wood on the outside. Arco, Winterswijk, the Netherlands. [www.arco.nl](http://www.arco.nl) **CIRCLE 289**

**Illuminated countertops**

The Corian Illumination collection from DuPont features Arctic Ice and Glacier Ice, translucent acrylic polymer blends for countertops. Dupont, Wilmington, Del. [www.countertops.dupont.com](http://www.countertops.dupont.com) **CIRCLE 290**

**Patterned fences**

Lace Fence is a refreshing take on the ubiquitous chain-link fence. Produced by hand for indoor or outdoor use, designs can be created to help discourage climbers, or to hide or enhance surroundings. Demakersvan, Rotterdam. [www.demakersvan.com](http://www.demakersvan.com) **CIRCLE 291**

**Twisting reflection**

To get to toiletries stored in this bathroom cabinet, simply twist the rotating horizontal mirror into a vertical position. Boffi USA, New York City. [www.boffi.com](http://www.boffi.com) **CIRCLE 292**

**Glass-and-steel boxes**

Grimshaw Architects developed the design for 330 newsstands, 20 automatic public toilets, and 3,300 glass-and-steel bus stops being installed by Cemusa throughout New York City. Cemusa expects to recycle the old structures as well as the stainless-steel and glass components of the new street furnishings at the end of their life cycle. Cemusa, New York City. [www.cemusany.com](http://www.cemusany.com) **CIRCLE 293**



# Timely's® Total Opening Concept Assures High Performance.

Timely's prefinished steel door frames have the flexibility to go wherever your imagination takes you in color coordination and interior design. Timely offers unmatched quality and performance with sturdy, full perimeter anchoring, corner alignment for perfect miters, 90-minute fire rating and fast, easy installation.

## Timely Trim Options

We widen your creative horizons with prefinished steel frames featuring our "snap-lock" casings in five profiles including steel, aluminum and PVC.

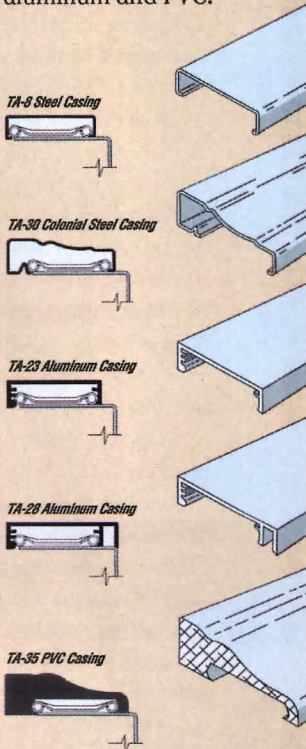

*Wood Casings (provided by others) ideal for the strength and economy of a steel frame and the charm of wood millwork.*

## Timely's Durable, Polyester Coatings

Choose from six standard or 29 custom colors, or we'll match any color you wish.

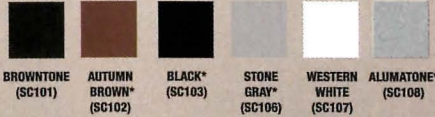

\*This color has a slight upcharge.

Colors shown may vary slightly.

Unique features add up to attractive, economical and stronger door frame installations.



1 Casing Corner Connectors hold mitered corners in tight fixed positions. MiterGard® featured on TA-9 casings.

2 Full-Width Alignment Tabs correctly align frame sides and header.

3 Individually Attached, Heat-Treated Casing Clips assure a snug casing fit that follows the irregularity of walls.

4 Pre-Punched Fastener Holes mean easier fastening.

5 Oval Alignment Slots allow visual check of frame spacing and adjustment during installation.

6 14 Gauge Hinge Reinforcement Plates are factory attached to give hinge strength of a 12 gauge frame.

Adjustable Strike permits full 1/4" adjustment, assures positive, rattle-free fit.

TA-10 Reinforcement Bracket is one of many reinforcements for door guards and closers and other hardware applications.

Reversible Hardware Locations mean no handling in 6'8" or 7'0" heights.



# TIMELY

PREFINISHED STEEL DOOR FRAMES

A DIVISION OF S.D.S. INDUSTRIES, INC.

Timely Corporate Offices: 10241 Norris Ave., Pacoima, CA 91331-2292 / 818-492-3500 / 800-247-6242 / Fax 818-492-3530  
 Eastern Distribution Center: 9789 Interocean Drive, Cincinnati, OH 45246 / 513-682-9600 / 800-346-4395 / Fax 513-682-4102  
 Georgia: 4718 Hammernill Road, Tucker, Georgia 30084 / 770-493-8811 / 800-445-8899 / Fax 770-491-1653  
[www.timelyframes.com/ar](http://www.timelyframes.com/ar)

CIRCLE 70 ON READER SERVICE CARD OR GO TO [ARCHRECORD.CONSTRUCTION.COM/PRODUCTS/](http://ARCHRECORD.CONSTRUCTION.COM/PRODUCTS/)



# Conveying Systems

Elevators • Custom elevator cab finishes • Elevator equipment & controls

## Cut-rate customization

Made with over 90 percent recycled content, CabForms Elevator Systems offer design features associated with custom cabs at a lower price. Each CabForms package includes wall panels, trim pieces, handrails, light fixtures, and ceiling. Material options include stainless steel and Forms+Surfaces' exclusive Fused Metals, all available in different patterns and finishes (many of which have low or no VOCs). Once installed, the modular system allows for replacement of single damaged panels, rather than the whole cab. Forms+Surfaces, Carpinteria, Calif. [www.forms-surfaces.com](http://www.forms-surfaces.com) **CIRCLE 294**

## Two in one

First introduced in 2003, ThyssenKrupp's Twin system offers two independent cabs running in one shaft. By taking up less room than conventional elevators, the system frees up valuable space. In addition, none of the elevators' switches or cables are visible. The first two panoramic Twin systems in the world have been recently installed in the Main Triangel building in Frankfurt, Germany (shown), allowing the architects to maintain the light, open concept of the largely glass facade. ThyssenKrupp also just received a contract to install five Twins at the Royal London Hospital as part of the facility's extensive renovation; three of which will be designed for the first time as bed elevators. ThyssenKrupp Elevator, Dallas. [www.thyssenkruppelevator.com](http://www.thyssenkruppelevator.com) **CIRCLE 295**

## Intelligent ID

The Schindler ID human interface system is the first elevator control system for mid- and high-rise buildings that customizes service for each passenger by employing electronic identification badges and other widely used devices. Designed to work in tandem with Schindler's Miconic 10 system, the new Schindler ID system improves traffic handling and efficiency by up to 30 percent. It also incorporates special features for assisting handicapped or special-needs individuals. Schindler Elevator Corporation, Morristown, N.J. [www.us.schindler.com](http://www.us.schindler.com) **CIRCLE 296**

Elevators that sort passengers and compute the shortest, most economic trips seem inevitable. —JACOB ALSPECTOR

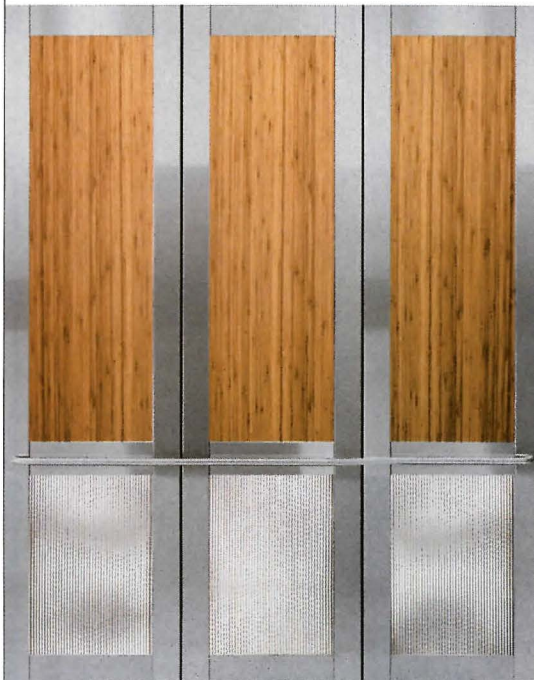

294



296



295



# Plumbing, HVAC & Special Construction

Domestic water-filtration equipment • Residential plumbing fixtures • HVAC air distribution  
 • Radiant-heating units • Steam baths & equipment • Whirlpool spas & hot tubs

## Don't be touchy

Destiny is an ADA-compliant, hands-free faucet designed exclusively for the powder room. Destiny's infrared sensors detect motion to start and stop the flow of water, limiting water waste and aiding in conservation. ShowHouse by Moen, North Olmstead, Ohio.

www.showhouse.moen.com **CIRCLE 297**

## Inside the box

At a room- and people-friendly 55" square x 28" high, the Blue Moon "pool" tub by Berlin-based designer Jochen Schmidden, features a circular 21"-deep acrylic tub rimmed by a teak or matching deck, plus optional lighting, bench, and stainless-steel clothes stand. Duravit, Duluth, Ga. www.duravit.com **CIRCLE 298**

## Hot topic

The Outline radiator, designed by Paul Priestman, is a flattened oval loop of coiled steel tubing that comes in a horizontal version in two sizes and a vertical version in three sizes. Outline can be finished in aluminum or metallic white. Bisque Radiators, Bath, England. www.bisque.co.uk. **CIRCLE 299**

## Fool the eye

When French designer Jean-Marie Massaud developed his namesake collection, he aimed to make the plumbing recede. Thus organically sculpted single-lever basin and bath mixers appear to be—indeed double as—shelves. Water delivery mimics the clarity of nature while keeping its use at bay. Axor, Alpharetta, Ga. www.hansgrohe-usa.com **CIRCLE 300**

## Lightweight concrete sinks

Available in three styles, Syndecrete sinks fit standard cabinet bases and are available in 37" x 23" or 31" x 23" sizes. The sinks are made of lightweight Syndecrete, a cementitious composite and solid surfacing material that uses natural minerals and recycled materials as its primary ingredients. The sinks can be sanded and skim-coated and feature a solid 4" lip rarely seen in precast-concrete products. Recycled carpet fibers help keep the product lighter in weight than ordinary concrete. Syndecrete, Santa Monica, Calif. www.syndecrete.com **CIRCLE 301**



297



298



299

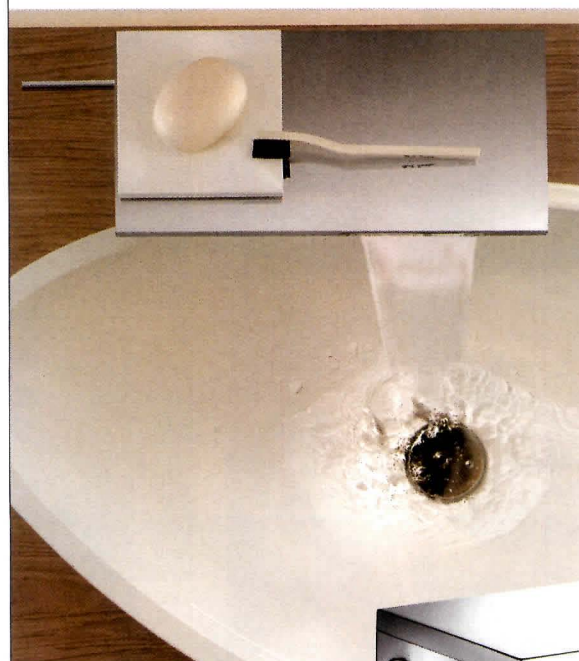

300



301





It's really exciting to see environmentally conscious plumbing fixtures start to address issues of good, clean design, such as the Vitra toilet. —CHARLES RENFRO, AIA



303



304



**Showering au natural**

Designed by Sieger Design, the Under the Tree stainless-steel garden shower can be fitted quickly and securely into the grass thanks to an extra-long ground spike. The water supply is provided by connecting a garden hose directly to it. The defined holes at the end of one of the branches ensure that water comes down in a soft jet. Conmoto, Herzebrock-Clarholz, Germany. [www.conmoto.com](http://www.conmoto.com)

**CIRCLE 302**

**Easy ergonomics**

The Hansapurejet fully chromed hand shower is designed to fit naturally in the palm of one's hand and provide versatility. Included in the Hansapurejet collection is an adjustable wall bar (its length can vary between 24" and 36") and features anticalcification knobs that fight lime. While easily combined with other Hansa showers, the Hansapurejet can be integrated into other shower designs and is ideal for Universal Design accessibility. KWC America, Norcross, Ga. [www.hansa.com](http://www.hansa.com) **CIRCLE 303**

**A touch of class**

Taking cues from Art Nouveau glamour, RSVP bath fittings and accessories are all about subtle curves accented with a bit of "bling" by way of optional Swarovski crystal. Available in chrome and brushed bronze or nickel, even the overhead shower maintains a shapely silhouette. Brizo, Indianapolis. [www.brizo.com](http://www.brizo.com) **CIRCLE 304**



# Plumbing, HVAC & Special Construction

Domestic water-filtration equipment • Residential plumbing fixtures • Steam baths

## Singing in the shower

Kohler's DTV II with WaterTile Ambient Rain and SoundTile Shower Speakers (detail of speaker, inset) improves upon the original DTV system by controlling sound, chromatherapy, and a personalized steam system. A user-friendly digital control panel brings water, sound, light, and steam together for a personalized showering experience. Also from Kohler is the Antila Wading Pool lavatory (not shown), a glass countertop lav that features slightly curved edges along its perimeter to contain water and a subtle texture across its surface. Kohler, Kohler, Wis. [www.kohler.com](http://www.kohler.com) **CIRCLE 305**

## Water, water everywhere

HousePure Whole-House Water Filtration System uses carbon made from coconut shells along with a media guard featuring nearly 5 pounds of KDF-55 bacteriostat to make filtered water available at every faucet and appliance in a house. The system filters the water without salt or caustic chemicals, which can harm the environment. Water Inc., Sacramento, Calif. [www.waterinc.com](http://www.waterinc.com) **CIRCLE 306**

## Less is more

Watermark's SH-1.5ADP showerhead adapter reduces water flow to 1.5 gallons per minute while giving the user the same feeling as using a 2.5-gallons-per-minute showerhead. Available in standard, designer, and exotic finishes. Watermark, Spring Creek, N.Y. [www.watermark-designs.com](http://www.watermark-designs.com) **CIRCLE 307**

## A new traditional toilet

VitrA's 1.2 gpf high efficiency toilet (HET) saves 25 percent more water annually by reducing the amount of clean water each time it is used. Despite the lower flush volume, the toilet performs like a traditional 1.6 gpf toilet. VitrA USA, Atlanta. [www.VitrA-usa.com](http://www.VitrA-usa.com) **CIRCLE 308**

## Steamy stainless

The new Mr. Steam steamhead improves on the older version with cooler surface temperatures, better steam flow, and quieter steam infusion. The steamhead can be integrated into a bath or shower and can be combined with the Aromasteam aromatic-oils system. The steamhead is compactly designed for durability and made of recyclable stainless steel. Mr. Steam, Long Island City, N.Y. [www.mrsteam.com](http://www.mrsteam.com) **CIRCLE 309**



305



306



308

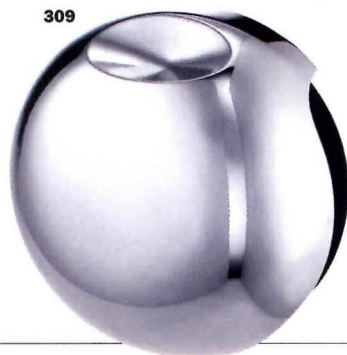

309



307



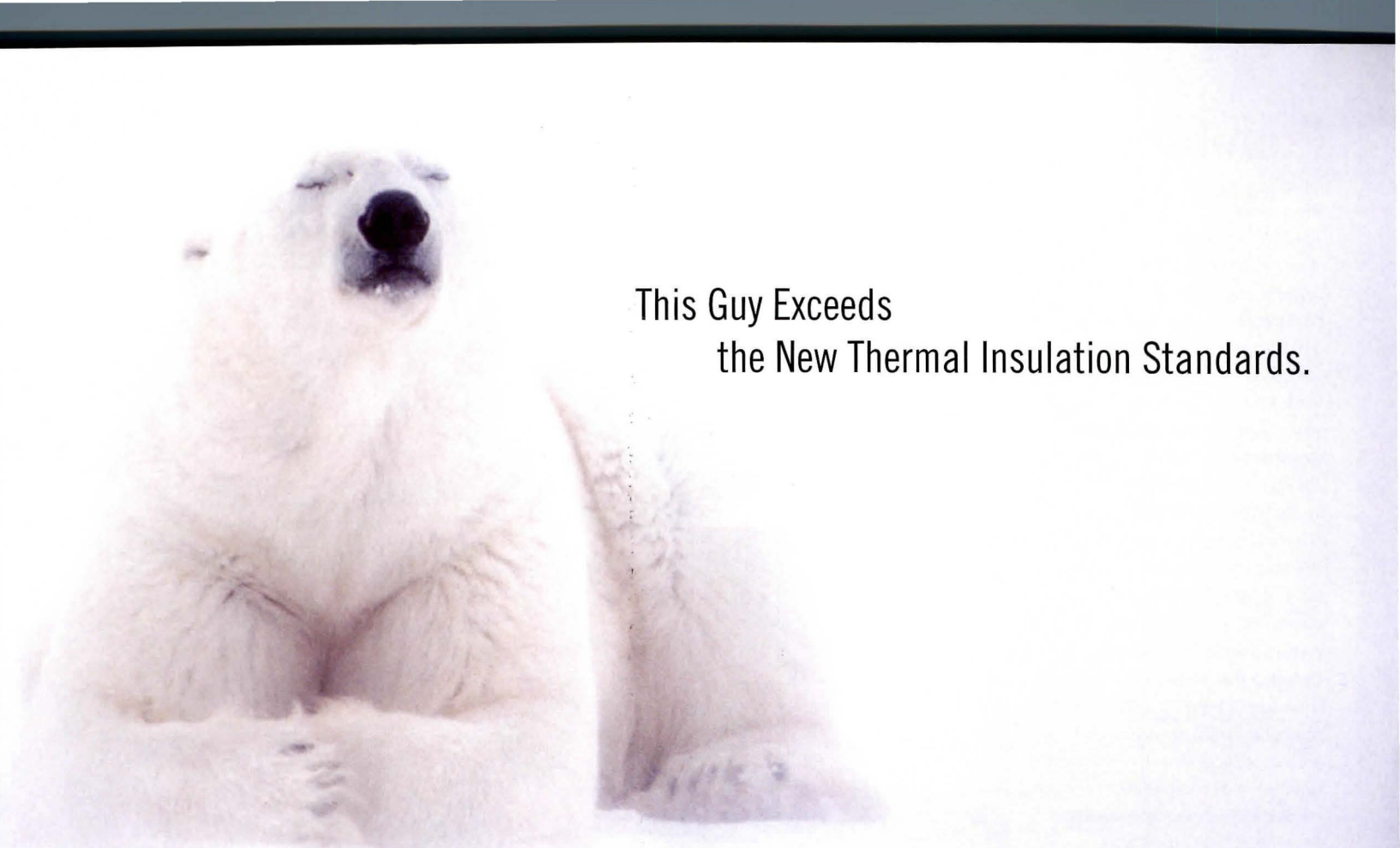

This Guy Exceeds  
the New Thermal Insulation Standards.



So Does This Guy.

Thermal efficiency matters to us all. In fact, ASHRAE recently raised its standards for thermally efficient insulation across the United States. Traditional insulated steel studs may result in significant heat loss for your designs. Smarter designs call for insulated metal panels. Insulated metal panels, with two and three-inch thick insulation outboard of metal stud supports, improves R-values up to R-14 and R-20. This increased thermal efficiency meets the new ASHRAE standards, and never looks bearish. No matter what the weather will be, trust in factory assembled insulated metal panels to insulate more efficiently.



Metal Construction Association

[www.metalconstruction.org/imp](http://www.metalconstruction.org/imp)

CIRCLE 71 ON READER SERVICE CARD OR GO TO  
[ARCHRECORD.CONSTRUCTION.COM/PRODUCTS/](http://ARCHRECORD.CONSTRUCTION.COM/PRODUCTS/)



# Plumbing, HVAC & Special Construction

Domestic water-filtration equipment • Residential plumbing fixtures • Steam baths

### Flex time

The KWC Ono features a patented "highflex" spring hose that swivels 360 degrees. A two-stage operating system produces two types of water stream: a practical filtered stream and a powerful pressurized stream for removing food residue. KWC America, Norcross, Ga. [www.kwcamerica.com](http://www.kwcamerica.com) **CIRCLE 310**

### Comfort control

The Therma-Fuser Diffuser controls air flow to match requirements of a portion of a room, giving occupants the option of individual temperature preferences. Use of the Therma-Fuser can gain LEED certification points. Acutherm, Hayward, Calif. [www.acutherm.com](http://www.acutherm.com) **CIRCLE 311**

### Feeling the heat

Laticrete's FahrenHEAT system is a comprehensive floor-warming system that requires no dangerous near-wire stapling or nailing. The mat's self-adhesive mesh keeps it in place, and the low-profile wiring is virtually undetectable beneath hard tile flooring. Laticrete, Bethany, Conn. [www.laticrete.com](http://www.laticrete.com) **CIRCLE 312**

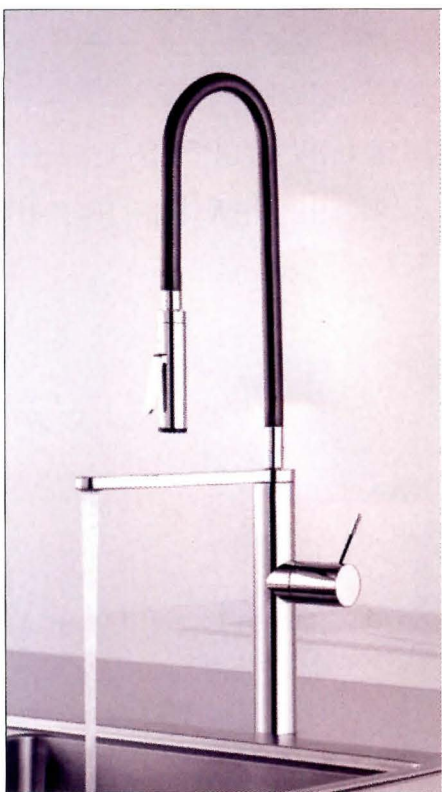

310

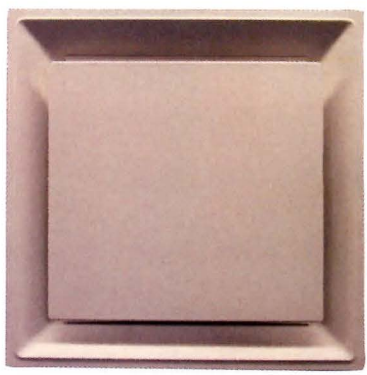

311



312

## *Optimum Luxury in Decorative Hardware*

# Zwei L

Zwei L, a new series of 316 stainless steel hardware collection from Sugatsune. The mirrored and fine satin finish creates remarkable visual appeal combined with the forged construction that makes this collection a one of a kind. The Zwei L collection will accent any home or venue with an ultra modern impression.

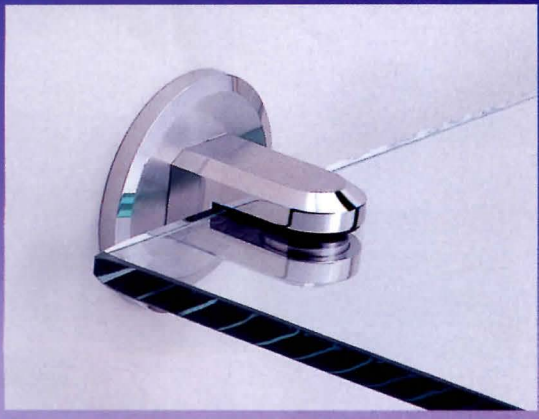

Sugatsune America, Inc.  
800-562-5267  
[www.sugatsune.com](http://www.sugatsune.com)  
[sales@sugatsune.com](mailto:sales@sugatsune.com)  
[www.ZweiL.com](http://www.ZweiL.com)

**CIRCLE 72 ON READER SERVICE CARD OR GO TO**  
[ARCHRECORD.CONSTRUCTION.COM/PRODUCTS/](http://ARCHRECORD.CONSTRUCTION.COM/PRODUCTS/)



# Electrical

Lighting control devices • Power distribution units • Interior lighting fixtures, lamps & ballasts • Special-purpose lighting • Exterior lighting • Wind-energy equipment

## Lane of light

Lane is a family of lamps that create a diffused lighting effect upward and downward on the wall. Made of extruded and die-cast aluminum, it is available in various lengths and in a version with an integrated-acoustic-diffusion system or LED spotlighting. Luceplan, New York City. [www.luceplan.com](http://www.luceplan.com) **CIRCLE 313**

## Take it to task

Powered by 18 LED lights, the Brazo task lamp offers focus control, making it ideal for use above computer monitors as it allows the user to both direct and choose any light spread without producing light spill. The lamp features 360-degree head rotation and height adjustment from 14" to 21". Haworth, Holland, Mich. [www.haworth.com](http://www.haworth.com) **CIRCLE 314**

## Totally tubular

Initially designed for subways, stations, and parking lots, iSign also works well in offices, retail spaces, and exterior-interior borderline installations. Available in surface- and wall-mounted, horizontal, and vertical suspended versions with one or two modules. iGuzzini, Recanti, Italy. [www.iguzzini.com](http://www.iguzzini.com) **CIRCLE 315**

## Lucky slots

Designed by David Chipperfield, Slot is a series of indirect recessed fixtures ideal for spaces where a noninvasive lighting effect is desired. A metal structure houses dimmable fluorescent bulbs. FontanaArte, New York City. [www.fontanaarte.com](http://www.fontanaarte.com) **CIRCLE 316**

## Choosing sides

Bega's Wall Luminaire with one-sided or two-sided light output allows light to be directed softly through the matte safety glass onto the wall. It is available arranged individually, in rows, or in groups. Bega, Carpinteria, Calif. [www.bega-us.com](http://www.bega-us.com) **CIRCLE 317**

## Walk toward the light

Reno is an illuminating column whose understated aesthetic is suitable for accent, walkway, and landscape illumination, including zone definition for pedestrian areas. The aluminum column houses a top-mounted reflector for easy relamping. Hess America, Gaffney, S.C. [www.hessamerica.com](http://www.hessamerica.com) **CIRCLE 318**

Of the many lighting products submitted, some were practical, some attempted to be both aesthetically attractive and technologically innovative, and some were just works of art. —K. BRETT MALAK



313

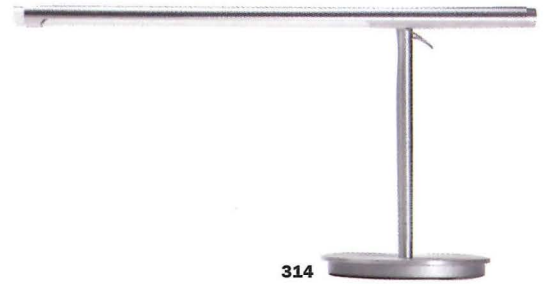

314



315



316

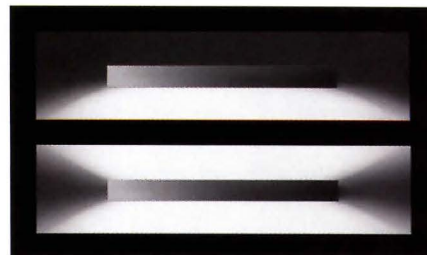

317



318



# Electrical

Lighting control devices • Power distribution units • Interior lighting fixtures, lamps & ballasts • Special-purpose lighting • Exterior lighting

## A kaleidoscope of colors

Lightspace's color-changing, interactive LED display systems have a range of applications. Their new LIT-16 pressure-sensitive tiles are available in either a white or clear polycarbonate shell with updated diffusion technology, allowing for brighter and more saturated colors and effects. Lightspace, Boston.

www.lightspacecorp.com **CIRCLE 319**



## Secret garden

The Skygarden pendant lamp designed by Marcel Wanders features a plaster body with a "hidden" textured decorative pattern on the inside. The exterior is finished in opal gold, or matte white, black, or rust paint. Available in 35" and 24" sizes. Flos USA, Huntington Station, N.Y.

www.flos.com **CIRCLE 320**



320

## Shifting gears

Lucifer Lighting's Gear Driven Downlights feature two concealed, self-locking, internal gear trains that allow trim rotation, tilt, and hot aim to be precision-adjusted from the room side with just a screwdriver. Lucifer Lighting, San Antonio.

www.luciferlighting.com **CIRCLE 321**

319

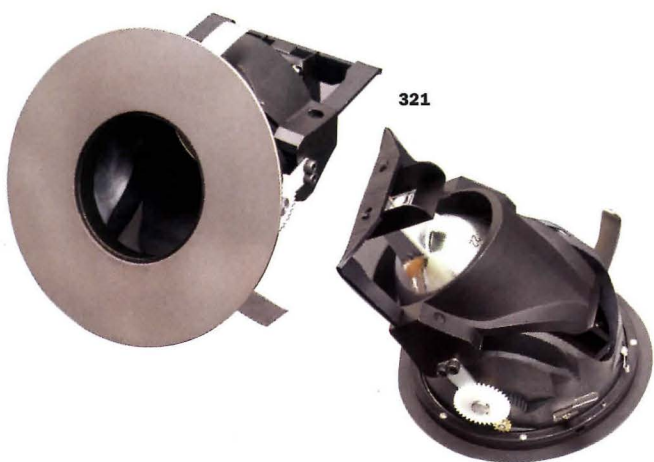

321

## Winsome white light

The Marlowe is an updated version of the traditional table lamp whose hand-blown glass, elliptical-shaped diffuser emits a soft, warm light. The stem and base are a combination of extruded and die-cast aluminum. Leucos USA, Edison, N.J.

www.leucos.com **CIRCLE 322**



322

## Don't tear down this wall

Convia Programmable Infrastructure eliminates the traditional "pipe and wire" approach to delivering electricity by allowing for the complete virtual rewiring of a space in minutes. Switches, lighting, or other electrical devices become nodes on a network. Programming is via a two-button wand or an easy-to-navigate Web portal. Convia, Buffalo Grove, Ill.

www.convia.com **CIRCLE 323**

## LED panel displays

The LC series is a semitransparent, modular system of LED panels ideal for displaying film, digital images, and graphics for stage, TV studio, and commercial applications. The extremely bright units offer true RGB possibilities that ensure output is always balanced and uniform. Martin Architectural, Sunrise, Fla.

www.martinarchitectural.com **CIRCLE 324**

323



324

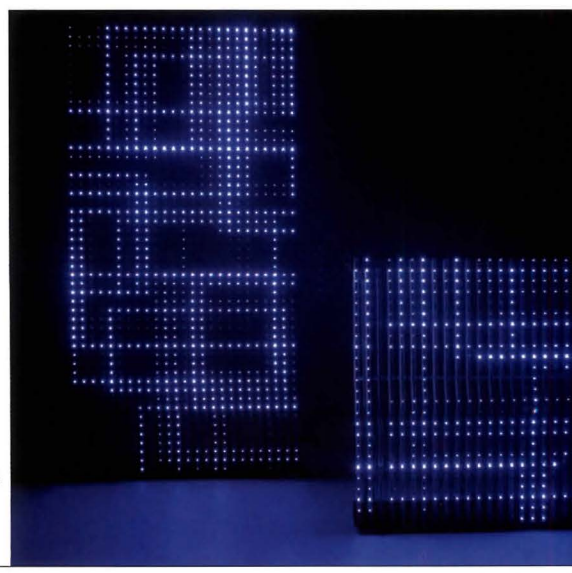



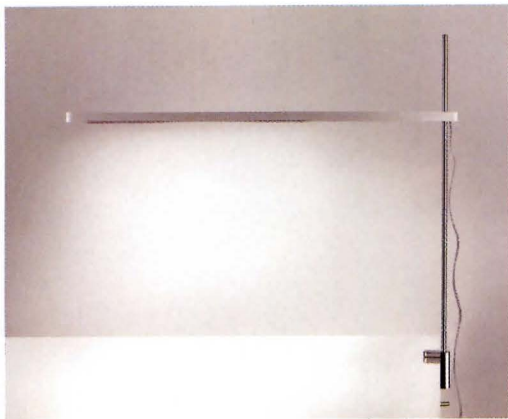

325

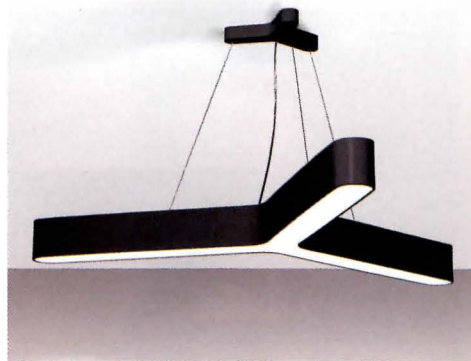

326

**Put to the task**

Designed by Neil Poulton, the minimal Talak task lamp offers direct, adjustable fluorescent lighting. The extremely slim body, made from injection-molded thermoplastic, rotates 360 degrees and can be adjusted in height by sliding it along the chrome stem. Artemide USA, New York City. [www.artemide.us](http://www.artemide.us) **CIRCLE 325**

**Armed with light**

Gear 3 is a three-armed, suspended luminaire whose aluminum body features a satin-finished acrylic cover that provides gentle, even illumination. Available in white, black, or gray. Xal, New York City. [www.xal.com](http://www.xal.com) **CIRCLE 326**



327

**Finding the way in the dark**

StumbleLight is a motion-activated, night guiding light that turns on when a hotel guest steps out of bed. It is placed under a nightstand or on a wall to illuminate a path. The LED source provides soft and unobtrusive light. Philips, Somerset, N.J. [www.usa.philips.com](http://www.usa.philips.com) **CIRCLE 327**

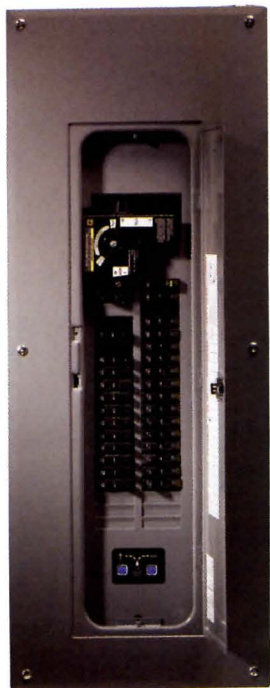

328

**Two-in-one load center**

The Intelligent Transfer Switch eliminates the need for a second distribution panel and additional wiring for a standby residential generator. Should a power failure occur, it automatically transfers the electrical load to the generator. Kohler Power Systems, Kohler, Wis. [www.kohlersmartpower.com](http://www.kohlersmartpower.com) **CIRCLE 328**

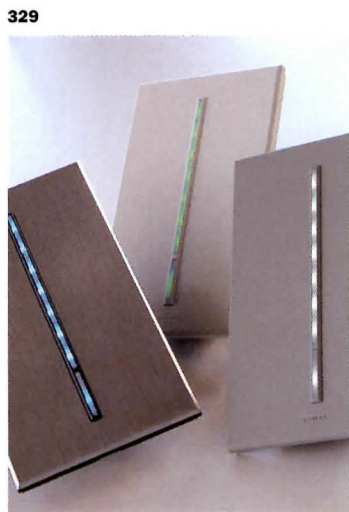

329

**Touchy lighting control**

The Verti architectural touch dimmer offers multilocation dimming with adaptive LEDs that brighten when pressed, and glow softly at rest. Available in a variety of wall-plate colors and finishes. Lutron Electronics, Coopersburg, Pa. [www.lutron.com](http://www.lutron.com) **CIRCLE 329**



330

**Enjoy a bright, long life**

Sylvania's Dura-One Ecologic electrodeless, medium-base compact fluorescent lamps have an average rated life of up to 15,000 hours. Available in BR30 and A19 configurations. Osram Sylvania, Danvers, Mass. [www.sylvania.com](http://www.sylvania.com) **CIRCLE 330**

**Cut the lights**

Allowing light to escape from a simple, cut aluminum tube, either toward the ceiling for ambient lighting or at the floor for night lighting, Toobo is available in indoor and outdoor, wall and floor, and short and tall versions. FontanaArte, New York City. [www.fontanaarte.com](http://www.fontanaarte.com) **CIRCLE 331**



331



# Electrical

Lighting control devices • Power distribution units • Interior lighting fixtures, lamps & ballasts • Special-purpose lighting • Exterior lighting

## Frosted transparency

The Vetro series of round downlights features striking combinations of hand-blown opal and clear glass diffusers in various shapes and sizes with satin aluminum rings. Lightolier, Fall River, Mass. [www.lightolier.com](http://www.lightolier.com) **CIRCLE 332**



332

## Domestic energy policy

Skystream 3.7 is a small wind generator designed for utility-connected residential use, allowing homeowners to harness wind energy and lower their energy bills. Designed for very low winds, it begins producing power in an 8-mph breeze, with full output achieved at 23-mph. Southwest Windpower, Flagstaff, Ariz. [www.skystreamenergy.com](http://www.skystreamenergy.com) **CIRCLE 333**



333

## A thousand points of light

eW Flex SLX is a versatile strand of 50 white LED nodes, each composed of five LEDs and individually controlled. The durable, flexible form, composed of a polycarbonate lens and housing, allows for dynamic points of white light to be installed across nearly any interior or exterior surface. It is also suitable for lighting tight alcove spaces and signage. Color Kinetics, Burlington, Mass. [www.colorkinetics.com](http://www.colorkinetics.com) **CIRCLE 334**



334

## Get a grip

Heyco-TITE large-size, liquid-tight cord grips now handle larger cable diameter ranges. An integral sealing ring ensures a lasting liquid-tight seal at the mounting location. Molded of high-impact polyamide nylon. Heyco, Toms River, N.J. [www.heyco.com](http://www.heyco.com) **CIRCLE 335**



335

## In the mix

LinearLight flexible and rigid LED modules offer simple control for creating dynamic color-mixing and color-sequencing effects. For use as edge lighting and detailing, and for building facades, cove lighting, and illumination of transparent materials. Osram Sylvania, Danvers, Mass. [www.sylvania.com](http://www.sylvania.com) **CIRCLE 336**

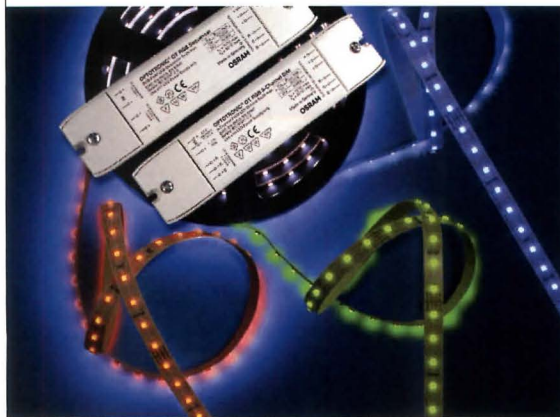

336

## Project greenlight

Alto II is Philips' next-generation, low-mercury fluorescent-lamp technology for the professional lighting market. Alto II T8 lamps now contain only 1.7 mg of mercury, a 50 percent reduction from previous levels, but with the same long life, energy efficiency, and lumen output. Philips, Somerset, N.J. [www.philips.com/alto2](http://www.philips.com/alto2) **CIRCLE 337**



337



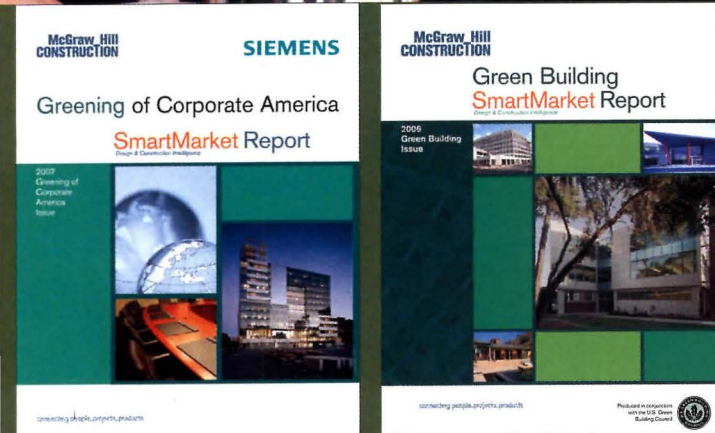

## McGraw-Hill Construction: Your source for green market intelligence

McGraw-Hill Construction:  
We know the green marketplace.

Let us help you turn  
'green' into green \$.

Call 1.800.591.4462

McGraw-Hill Construction can answer your questions about how green affects all aspects of the construction marketplace.

Whether you're interested in the commercial, residential, education, healthcare, or another building segment, we have the intelligence, know the trends, can tell you what the market is thinking, and the impact of your brand.

We have conducted research on the 'greening' of corporate America, and we can help you determine how you can grow your green business and increase your market share.

**Our custom research and analytics can help you**

- assess your brand identity
- know how much of the green market you are capturing
- learn how to move your business forward
- gain more of this fast growing market

For McGraw-Hill Construction's Green SmartMarket Reports, visit [www.construction.com/greensource/reports.asp](http://www.construction.com/greensource/reports.asp)



## New and Upcoming Exhibitions

### Shenzhen—Hong Kong Biennale Hong Kong

December 1, 2007–March 1, 2008

Qingyun Ma, dean of the University of Southern California School of Architecture, will be the curator of the first two-city biennale that opens simultaneously in Hong Kong and Shenzhen. "City of Expiration and Regeneration" is the theme of the biennale, which will explore the notion of the life cycle of built environments and the need for revitalization to take advantage of new materials, technology, and resource-management techniques, as well as accommodate changing trends in the way people live, work, play, and

communicate. For additional information, visit [www.hkia.net](http://www.hkia.net).

### Map This! Envisioning a Global City Chicago

January 22–March 21, 2008

The Chicago Architecture Foundation joins 30 other cultural institutions for the City of Chicago's Festival of Maps with this new exhibition. At the Chicago Architecture Foundation (CAF). Call 312/922-3432 or visit [www.architecture.org](http://www.architecture.org).

## Ongoing Exhibitions

### Beyond the Portal: Great Public Spaces in New York New York City

Through December 21, 2007

# Dates & Events

This exhibition is inspired by a series of pictorial essays by Stan Ries that appeared in *Interior Design* magazine. The photographs explore nine dramatic interiors. At the New York School of Interior Design. Call 212/472-1500 or visit [www.nysid.edu](http://www.nysid.edu).

### Jane Jacobs and the Future of New York New York City

Through January 5, 2008

An interactive exhibition that highlights the relevance of activist and author Jane Jacobs and the urban design principles presented in her classic text *The Death and Life of Great American Cities*. The show explores contemporary New York through Jacobs's groundbreaking views on the elements of a healthy city, the value of small blocks, the

importance of civic activism, and the benefits of a diverse and dynamic neighborhood. It also encourages citizen involvement by helping visitors begin engaging in their own neighborhoods. At the Municipal Art Society's Urban Center galleries. Visit [www.rock-found.org](http://www.rock-found.org) or [www.mas.org](http://www.mas.org) for more information.



### Berlin/New York Dialogues New York City

Through January 26, 2008

The exhibition explores lessons learned through the cross-fertilization of ideas among citizens, policy makers, institutions, and design professionals in Berlin and New York, focusing on exemplary practices and strategies affecting city



**pinta** acoustic

formerly illbruck acoustic, inc.

Create Natural Beauty.  
Preserve Natural Resources.



BIOLINE  
Wood Ceiling Tiles

Made from 70% and 80% recycled, post-industrial material, BIOLINE™ Wood Ceiling Tiles are environmentally friendly and add warm elegance to any décor. Choose from two distinctive Class 1 fire-rated styles:

- Solid-Finish perforated or un-perforated tiles in cherry (natural or red), bamboo (natural or caramel), beech or maple natural wood veneer contain 70% recycled, post-industrial material.
- Organic-Texture tiles, offered in three shades, have NRCs of 55, 65\* and 80\* and contain 80% recycled, post-industrial material.

Create a beautiful impression with BIOLINE Wood Ceiling Tiles. And check out pinta's other attractive acoustical products, including CONTOUR® and HARMONI® Ceiling Tiles, SQUARELINE® Metal Ceiling Tiles, FABRITEC™ Wall Panels and SONEX® Panels and Baffles.



1-800-662-0032

[www.pinta-acoustic.com/ceiling](http://www.pinta-acoustic.com/ceiling)

\*Using willtec® acoustical foam or fiberglass backer.

© 2007 pinta acoustic, inc. All rights reserved.



planning and new building. Using a variety of imagery, illustration, and drawings, the exhibition describes social, political, economic, and cultural processes through current works of architecture and urban planning. At the Center for Architecture. Call 212/683-0023 or visit [www.aiany.org](http://www.aiany.org).

**Architecture for Humanity: Gulf Coast Reconstruction Projects St. Louis**

*Through January 26, 2008*  
This exhibition features a selection of residential designs, created under the auspices of the not-for-profit humanitarian group Architecture for Humanity, for displaced Gulf Coast communities like Biloxi, Mississippi, following Hurricane Katrina in 2005. The exhibition includes seven projects, some of which are already in construction, by architects from across the country. At the Bernoudy Gallery of Architecture. Visit [www.thesheldon.org/galleries](http://www.thesheldon.org/galleries).

**75 Years of Architecture at MoMA New York City**

*Through March 10, 2008*  
MoMA's Department of Architecture, founded in 1932, was the world's first curatorial department of its kind. This exhibition of drawings and models from the collection celebrates the department's 75th birthday and demonstrates the development of its collecting practice, with a number of recent acquisitions on view, including several drawings by Oscar Neimeyer, displayed in honor of his 100th birthday. At the Museum of Modern Art. Call 212/708-9400 or visit [www.moma.org](http://www.moma.org).

**Eero Saarinen: Shaping the Future Bloomfield Hills, Michigan**

*Through March 30, 2008*  
Traveling from Europe, this exhibition is the first retrospective of the life and works of one of the more celebrated designers of the Modern era. Saarinen is best known for his post-

war masterpieces, including the 630-foot-tall stainless-steel St. Louis Gateway Arch, the TWA terminal at New York's John F. Kennedy Airport, numerous university campus plans and buildings, and the General Motors Technology Center near Detroit. At the Cranbrook Art Museum. Call 248/645-3323 or visit [www.cranbrookart.edu/museum](http://www.cranbrookart.edu/museum) or [www.eerosaarinen.net](http://www.eerosaarinen.net).

**Lectures, Conferences, and Symposia**

**AIA 150 2007 Professional Excellence Awards Chicago**

*December 6, 2007*  
AIA Chicago will announce the winners of its Professional Excellence Awards. The chapter will name the winners of the 2007 Firm Award, the Dubin Family Young Architect Award, and the Distinguished Service Award. The awards presentation is part of AIA Chicago's Annual

*Meeting. At the University Club in Chicago. Visit [www.aiachicago.org](http://www.aiachicago.org).*

**Lecture: Toyo Ito Los Angeles**

*December 10, 2007*  
Toyo Ito is known for creating extreme conceptual architecture in which he seeks to meld the physical and virtual worlds. He is a leading exponent of architecture that addresses issues of the contemporary notion of "simulated" city. At UCLA Department of Architecture and Urban Design, Perloff Hall. Call 310/267-4704 or visit [www.aud.ucla.edu](http://www.aud.ucla.edu).

**Tectonics: Making Meaning Eindhoven, the Netherlands**

*December 10-12, 2007*  
This is an international conference and student design competition. The chief government architect of the Netherlands, Mels Crowel, will open the conference. Speakers include Ken Yeang, Kenneth Frampton, Jesse Reiser, Mark Goulthorpe, Rogier van der Heide,



"We've used (ICC®) for more than a decade to help us keep our customer service and quality top notch. Better yet, the ICC plans examiner stays with our inspectors throughout the project life as part of the overall service. If we have questions or problems, they're there to help out."

LARRY BALLARD, CHIEF BUILDING OFFICIAL, DESTIN, FL

# PLAN REVIEW AT ITS BEST!

Years of experience and expert knowledge in all code disciplines, makes ICC the best choice for your plan review needs.

**VISIT [www.iccsafe.org/prar](http://www.iccsafe.org/prar) and let our customers tell you why.**



People Helping People Build a Safer World™

CIRCLE 77 ON READER SERVICE CARD OR GO TO [ARCHRECORD.CONSTRUCTION.COM/PRODUCTS/](http://ARCHRECORD.CONSTRUCTION.COM/PRODUCTS/)





Copper that's worth  
**every penny.**

The best is always a better buy.  
Discover the outstanding performance of  
European Copper chimney pots today.  
[europeancopperchimney pots.com](http://europeancopperchimney pots.com)



tel. (800) 391-0014  
**EUROPEAN COPPER**  
BY JACK ARNOLD

PATENTED DESIGN | STOPS PESTS & WATER | UL LISTED

## Dates & Events

Chris Williams, Bert Dirrix, and others. The theme of the conference and the design competition is tectonics. At the Department of Architecture, Building and Planning at the University of Technology. Visit [www.tectonics2007.com](http://www.tectonics2007.com).

### Public Program: Design for Kids Chicago

December 19, 2007

Peter Exley, author, at the Chicago Architecture Foundation (CAF). Call 312/922-3432 or visit [www.architecture.org](http://www.architecture.org).

## Competitions

### South Street Seaport: Re-Envisioning the Urban Edge

#### Emerging New York Architects 2008 Biennial Competition

Registration Deadline: December 17, 2007

The principal element of the competition is a community center/galleries for the Seamen's Church Institute in New York City. The site straddles the edge of the East River between the South Street Seaport and the Brooklyn Bridge. This is an international competition, open to design students and young professionals who have completed their education within the past 10 years as of September 15, 2007. Visit [www.enyacompetitions.org](http://www.enyacompetitions.org).

### Multiplicity: The Art of the Furniture Prototype

Deadline: January 15, 2008

The competition is open to studio furniture makers, artists, architects, and industrial designers. Prototypes may be of any type of furniture in any materials—created since January 2000—and intended for production, whether small batch or mass production. Call 828/255-1949 or visit [www.furniture society.org/multiplicity](http://www.furniture society.org/multiplicity).



### Education Facility Design Awards

Deadline: December 21, 2007

The award program of the Committee on Architecture for Education (CAE). Selected projects enhance the client's educational program through the thoughtful planning and design of facilities as well as integrate function and aesthetics in designs that respect the surrounding community and context. The projects must incorporate a planning/design process that is educational and collaborative. Visit [www.aia.org/cae](http://www.aia.org/cae).

for the  
**GREENERGOOD**  
conversations that will change the world



Cell Phones (detail), 2007, by Chris Jordan

CONSUMER CULTURE ADAPTIVE  
REUSE SHORT LIFESPAN DESIGN  
CYCLE EXCESS DEMAND  
TECHNOLOGY ARTIFACT

## Living in a Disposable World

Recycling the Future.

Tuesday, December 18 • 6:30 – 8:00 PM

\$12 for museum members; \$20 nonmembers.  
Register online at [www.nbm.org](http://www.nbm.org).

For the Greener Good lecture series is presented by The Home Depot Foundation.



at the  
**NATIONAL BUILDING MUSEUM**  
Washington, DC

401 F Street NW Washington, DC 20001 | 202.272.2448 | [www.NBM.org](http://www.NBM.org)  
Red Line Metro, Judiciary Square



## THE SKYSCRAPER MUSEUM

39 Battery Place | New York, NY  
www.skyscraper.org

### Exhibition

FUTURE CITY 20 | 21  
NEW YORK MODERN

on view now!

An image-rich look at the prophecies of the skyscraper city in the early 20th century when the first dreams of a fantastic vertical metropolis took shape.

### Programs

Fall Booktalk Series  
at The Skyscraper Museum

December 12

Jim Rasenberger  
on his work *America 1908*  
skyscraper.org/programs

## Dates & Events

### The 99K House Competition

Deadline: January 14, 2008

A two-stage national competition to design a sustainable, affordable house that addresses the needs of the low-income family in the Gulf Coast region. The competition objectives are to broaden awareness of green building strategies applicable to affordable housing; generate and publicize buildable examples of sustainable, affordable houses; and construct an exemplary sustainable, affordable house prototype. For more information, visit [www.the99house.com](http://www.the99house.com).

### Jeld-Wen Student Design Competition

Deadline: February 29, 2008

Door manufacturer Jeld-Wen challenges students to design an entry door. Winners will be selected in spring 2008 by a panel of independent industry professionals and Jeld-Wen experts. The winning students' door designs will be announced at the Pacific Coast Builders Conference in San Francisco, June 25-27, 2008. Visit [www.jeld-wen.com](http://www.jeld-wen.com).

### Holcim Awards: For Sustainable Construction

Deadline: February 29, 2008

Past winners have included architects, urban planners, civil engineers, professors, industrial engineers, students, and a marine biologist. The Holcim Awards promote innovation in sustainable construction around the world. For more information, visit [www.holcimawards.org](http://www.holcimawards.org).

### 2008 National Student Steel Bridge Competition

May 23-24, 2008

This competition will take place at the University of Florida in Gainesville, Florida. Visit [www.2008steelbridge.com](http://www.2008steelbridge.com) for more information.

E-mail event and competition information  
two months in advance to  
[elisabeth\\_broome@mcgraw-hill.com](mailto:elisabeth_broome@mcgraw-hill.com).



## Natural Light

Introducing the ambia collection.  
More than 40 new lighting products  
featuring lenses with embedded  
textiles, graphics, organic elements,  
and more. See them all at  
[manningltg.com](http://manningltg.com)

ambia  
collection

Manning Lighting Inc. Sheboygan, WI USA  
p 920.458.2184 f 920.458.2491

CIRCLE 79 ON READER SERVICE CARD OR GO TO  
[ARCHRECORD.CONSTRUCTION.COM/PRODUCTS/](http://ARCHRECORD.CONSTRUCTION.COM/PRODUCTS/)



# SolarTrac<sup>®</sup>, the advanced WindowManagement<sup>®</sup> program

SolarTrac<sup>®</sup> is an innovative WindowManagement<sup>®</sup> system that operates in tandem with sophisticated solar shades. The program automatically controls the sun's heat and glare and offers views to the exterior—all to assure comfort and energy conservation. The system appreciably enhances the critical and positive operation of a base building—or the essential HVAC design—far beyond superficial and merely decorative window-covering treatments.

Considerations for technological window-covering solutions such as SolarTrac<sup>®</sup>—beyond the aesthetic design of roller screens or Venetian blinds—has instigated the kind of change that is currently transforming both built and natural environments.

“Global warming, political unrest in the Middle East and escalating energy costs are driving ideas for technological development as the first line of offense—targeting the high-rise office building due to its huge

impact on energy consumption and direct affect on global warming,” claims Joel Berman, chairman of MechoShade Systems, Inc., of Long Island City, New York. “Office towers serve as the quickest route to reduce energy consumption in the shortest time.”

SolarTrac<sup>®</sup>, now in its third generation, has at its core an automated shading technology that was developed by MechoShade Systems for IBM A/FE (IBM World Trade Americas/Far East Corporation) in the early 1970s.

As the most effective daylighting system available, SolarTrac<sup>®</sup> has advanced existing automated-shade technology by incorporating a number of superior features:

- The opportunity for daylighting occurs within 15 to 20 ft. of the peripheral interior space of an office floor. Thus, natural light can substitute for electric light to significantly reduce energy consumption. And studies show that a vast reduction in energy costs can be realized by more or less 40% in a typical office building.

- The use of natural daylight is maximized when the shades move incrementally and automatically on windows throughout the day according to the solar condition.

- Roof-mounted radiometers convey data to the SolarTrac<sup>®</sup> system for creating a sky-and-microclimatic model of the building in real time. The data are recorded as either clear/sunny or cloudy to control the shades in a fully raised position or in incrementally lowered positions, depending on the position of the sun and intensity of the solar ray.

- The optional Brightness-Override Module will automatically lower shades in those window zones where brightness is excessive, such as from an unexpected snowfall or the reflective surface of water.

- Another option, the Shadow-Override Module will automatically raise shades to take advantage of natural daylight when window zones are in the shadow of adjacent buildings, other structures or trees.

- The system can easily interface with a variety of 3rd-party building-management systems, such as lighting, A/V equipment and even existing motorized window-covering systems.

- A two-way communication system sends commands and provides responses that the commands have been executed.

- SolarTrac<sup>®</sup> compiles data for historic use and generates reports for use by the building management. Thus, over time, the system can learn the needs of the occupants and adjusts the program to meet those needs.

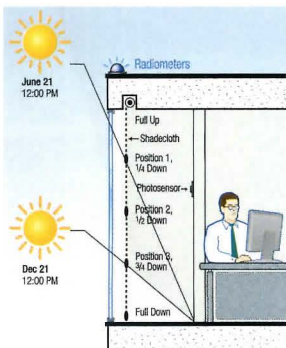

**Allowable solar penetration summer/winter: June 21/Dec. 21**  
Peak solar altitudes during the year on the south elevation 40°. North latitude with the SolarTrac<sup>®</sup> system preset to 6 or more positions plus user-defined solar penetration (3 ft./91 cm shown here).



**MechoShade Systems, Inc.**  
42-03 35th Street • Long Island City, NY 11101  
For more information call, Toll-free (800) 437-6360,  
or visit [www.mechoshade.com](http://www.mechoshade.com)







Rakks wall-mounted shelving at Christine Desirée Collection, Sarasota, FL Interior Design: Christine Desirée

### SUPPORTING SPATIAL EFFECTS



We play a supporting role in interiors that create harmony between decor and architecture. With strong, innovative shelving systems that meet the demands of the world's top designers. Rakks. The choice for new and exciting shelving solutions. Visit us at [www.rakks.com](http://www.rakks.com) or call for a free catalog.

**Rakks**

In supporting roles everywhere

Rangine Corporation | 330 Reservoir Street | Needham, MA 02494 | 800-826-6006 | [www.rakks.com](http://www.rakks.com)

CIRCLE 87 ON READER SERVICE CARD OR GO TO  
[ARCHRECORD.CONSTRUCTION.COM/PRODUCTS/](http://ARCHRECORD.CONSTRUCTION.COM/PRODUCTS/)

# DEX-O-TEX<sup>®</sup>

## Epoxy Terrazzo

From the Leaders in Fluid-Applied Flooring;  
Decorative, Functional & Durable Floors



Contact Us For More Detailed Products  
Information & Specification Assistance

800-823-0225

[www.dexotex.com](http://www.dexotex.com)

Dex-O-Tex Product Line  
by Crossfield Products Corp.

West Coast Office (310) 886-9100  
East Coast Office (908) 245-2800

CIRCLE 88 ON READER SERVICE CARD OR GO TO  
[ARCHRECORD.CONSTRUCTION.COM/PRODUCTS/](http://ARCHRECORD.CONSTRUCTION.COM/PRODUCTS/)

## Turning Gray Concrete GREEN

These microscopic, glassy spheres are fly ash – and at Headwaters Resources, we sell millions of tons of them every year.

Produced by burning coal at electric power plants, fly ash might be destined for disposal in a landfill. But when added to concrete, fly ash makes concrete easier to work, stronger and more durable.

Fly ash also enhances the environmental performance of concrete. Mining and manufacturing of natural raw materials can be reduced along with decreasing greenhouse gas emissions. In fact, using a ton of fly ash can save almost a ton of CO<sub>2</sub> emissions from being introduced into the atmosphere. In addition to concrete, fly ash is used in mortars, stuccos, paints, artificial stone, carpets, ceiling tiles, soil cement, pervious concrete and a variety of other building materials.

*That's an improvement worth specifying.*

Contact Headwaters Resources for  
free technical literature and information on  
how fly ash use benefits the environment.

**HEADWATERS**  
RESOURCES

[www.flyash.com](http://www.flyash.com) • 1-888-236-6236



CIRCLE 89 ON READER SERVICE CARD OR GO TO  
[ARCHRECORD.CONSTRUCTION.COM/PRODUCTS/](http://ARCHRECORD.CONSTRUCTION.COM/PRODUCTS/)

## Designed for Kitchens

A breakthrough! The first ever Power & Data Grommet that features a rubber collar to prevent water from getting into it when closed.

PCS34

Designed especially for kitchens, laboratories, medical offices, anywhere liquids could spill. The rubber ring forms a seal so liquid cannot get in. A simple yet effective improvement! PCS34 goes into a 3 1/8" hole. It comes with three 110 volt outlets and a 6' power cord. And has a lighted reset button. U.L. Listed.



"FINE ARCHITECTURAL HARDWARE FOR YOUR FINE FURNITURE"®

Doug Mockett & Company, Inc. • Manhattan Beach, CA • 800.523.1269

**MOCKETT**  
DOUG MOCKETT & COMPANY, INC.

[www.mockett.com](http://www.mockett.com)

CIRCLE 90 ON READER SERVICE CARD OR GO TO  
[ARCHRECORD.CONSTRUCTION.COM/PRODUCTS/](http://ARCHRECORD.CONSTRUCTION.COM/PRODUCTS/)



# he Architect's Hand

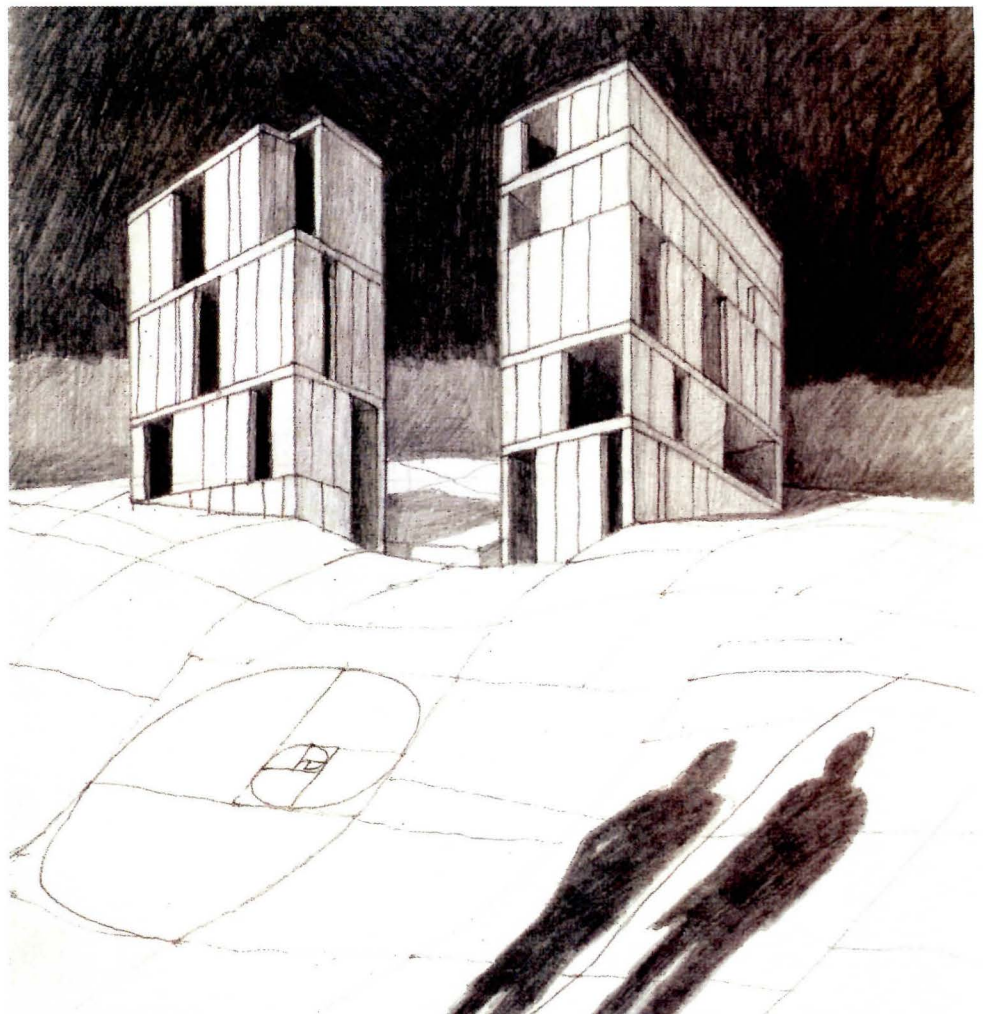
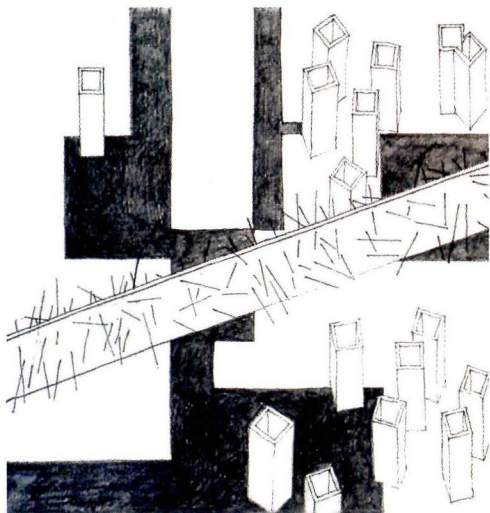
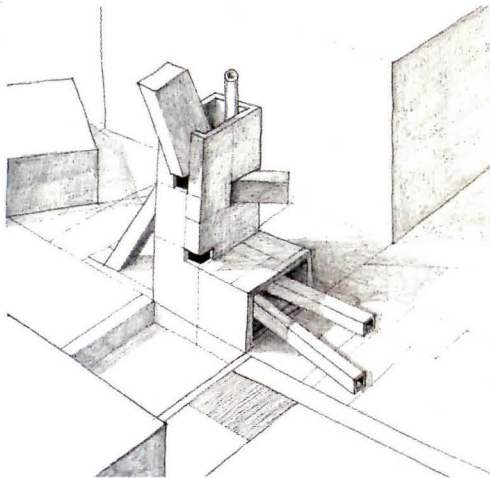

The three drawings above, done in 2006 (right) and 2007 (left two), demonstrate the many shades of black and white that can be wrought from graphite pencil on Coventry paper.

## Drawing to no particular end

"I've been thinking a lot about useless drawing lately," Caleb Crawford says. Crawford, the new director of the architecture school at Mississippi State University—Starkville, believes the act of drawing need not have a particular, concrete end. An equally valid reason to put pen to paper, or in his case, a variety of instruments (graphite, lead pointers, H or F leads, or 2H) to a 6-inch-square sketchbook, is to explore a range of abstract ideas.

Crawford recently began compiling his experimentations, which he calls "form poems," on his Web site, <http://formpoetrypolitics.blogspot.com>. Over "a year and change," Crawford has amassed roughly 200 sketches, most of which were conceived and completed in a day, then scanned in and posted online. While the computer has made assembling his drawings more efficient, Crawford won't be using a mouse and keyboard to create his form poems any time soon: "The computer is too precise," he says.

The drawings, which Crawford describes as "personal, political, layered," convey an alternate world of spooky interiors and surreal buildings. At certain times conceptually rigorous and at other times goofy, the drawings are not actually useless: They serve as a thought laboratory for his practice, Coggan Crawford—which Crawford started with his wife, Annie, in 1996—where he can examine the nature of space, shadow, and volume. *Diana Lind*



A BRAND NEW UNIT PAVER TECHNOLOGY FROM HANOVER®

**ARMAXENE™**



**P R O T E C T . E N H A N C E . C O M P L E T E .**

For years, acid rain, ultraviolet light and efflorescence have been a detriment to the appearance and longevity of natural finish concrete unit pavers. **ARMAXENE™** is a brand new unit paver technology developed by Hanover® Architectural Products to address these problems.

**ARMAXENE™** is NOT a top surface filled with tiny stones simply to produce a smooth finish. **ARMAXENE™** is a brand new paver technology designed to defend against natural elements such as acid rain, alkalis, efflorescence and ultraviolet light.

Hanover® Prest® Brick produced with **ARMAXENE™** Paver Technology will provide:

- outstanding protection from acid rain
- superior resistance to UV damage
- long lasting installation
- maintains bright, vibrant color
- low maintenance
- everlasting value
- virtual elimination of efflorescence

#### ACID RESISTANCE TEST

Hanover® Prest® Brick with **ARMAXENE™**



Competitor Brick

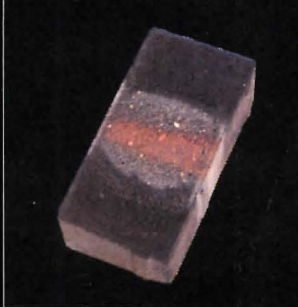

The bricks shown were subjected to equal amounts of muriatic acid in order to simulate 15-20 years of acid rain damage. Hanover's Prest® Brick with **ARMAXENE™** Technology showed little or no visible damage.

Only Hanover® Prest® Brick have **ARMAXENE™** Paver Technology, making them the educated choice of professionals and homeowners worldwide.

**HANOVER®**  
Architectural Products  
www.hanoverpavers.com • 800.426.4242

CIRCLE 91 ON READER SERVICE CARD OR GO TO [ARCHRECORD.CONSTRUCTION.COM/PRODUCTS/](http://ARCHRECORD.CONSTRUCTION.COM/PRODUCTS/)



**HAWORTH**<sup>®</sup>  
change by design

See the new Compose<sup>™</sup>  
furniture system – and other  
products and solutions –  
that help make workspaces  
great spaces.

Visit our new Dallas  
showroom or any of the  
other Haworth locations  
around the world.

[www.haworth.com](http://www.haworth.com)  
866.833.4343

**great spaces.**

709 B6 P 1784  
09/26/08 403062 <sup>™</sup>

CIRCLE 92 ON READER SERVICE CARD OR GO TO [ARCHRECORD.CONSTRUCTION.COM/PRODUCTS/](http://ARCHRECORD.CONSTRUCTION.COM/PRODUCTS/)